

**FOR PUBLICATION**

**UNITED STATES COURT OF APPEALS  
FOR THE NINTH CIRCUIT**

CALIFORNIA RESTAURANT  
ASSOCIATION, a California  
nonprofit mutual benefit corporation,

*Plaintiff-Appellant,*

v.

CITY OF BERKELEY,

*Defendant-Appellee.*

No. 21-16278

D.C. No.  
4:19-cv-07668-  
YGR

ORDER AND  
AMENDED  
OPINION

Appeal from the United States District Court  
for the Northern District of California  
Yvonne Gonzalez Rogers, District Judge, Presiding

Argued and Submitted May 12, 2022  
San Francisco, California

Filed April 17, 2023  
Amended January 2, 2024

Before: Diarmuid F. O'Scannlain and Patrick J. Bumatay,  
Circuit Judges, and M. Miller Baker, \* Judge.

---

\* The Honorable M. Miller Baker, Judge for the United States Court of International Trade, sitting by designation.

Order;  
Opinion by Judge Bumatay;  
Concurrence by Judge O'Scannlain;  
Concurrence by Judge Baker;  
Dissent from Denial of Rehearing En Banc by  
Judge Friedland  
Statement Respecting Denial of Rehearing En Banc by  
Judge Berzon

---

## SUMMARY\*\*

---

### **Energy Law / Preemption**

The panel issued (1) an order amending its opinion, Judge O'Scannlain's concurrence, and Judge Baker's concurrence filed on April 17, 2023; denying a petition for rehearing en banc; and ordering that no future petitions will be entertained; and (2) an amended opinion reversing the district court's dismissal of the California Restaurant Association's action alleging that the federal Energy Policy and Conservation Act (EPCA) preempts a City of Berkeley regulation that prohibits the installation of natural gas piping within newly constructed buildings.

The panel held that the Association, whose members include restaurateurs and chefs, had Article III associational standing to bring this suit.

---

\*\* This summary constitutes no part of the opinion of the court. It has been prepared by court staff for the convenience of the reader.

Based on its text, structure, and context, the panel held that EPCA preempts building codes like Berkeley's ordinance that ban natural gas piping within new buildings. The panel wrote that, in dismissing the suit, the district court limited EPCA's preemptive scope to ordinances that facially or directly regulate covered appliances, but such limits do not appear in EPCA's text. EPCA's preemption provision extends to regulations that address the products themselves *and* building codes that concern their *use* of natural gas. By enacting EPCA, Congress ensured that States and localities could not prevent consumers from using covered products in their homes, kitchens, and business. EPCA thus preempts Berkeley's building code, which prohibits natural gas piping in new construction buildings from the point of delivery at the gas meter.

Concurring, Judge O'Scannlain wrote that he agreed that EPCA preempts the Ordinance, but he only reached that conclusion because, under Ninth Circuit precedent, he was bound to hold that the presumption against preemption does not apply to the express-preemption provision at issue. He wrote that the issue presents a challenging question in a deeply troubled area of law—namely, which of the apparently conflicting lines of cases the court should follow in applying the presumption against preemption in express-preemption cases.

Concurring, Court of International Trade Judge Baker wrote separately to express his reservations about the Association's standing and to explain his view of why the ordinance invades the core area preempted by EPCA.

Judge Friedland, joined (except as to the first sentence and accompanying footnote) by Chief Judge Murguia and

Judges Wardlaw, Gould, Koh, Sung, Sanchez, and Mendoza, dissented from the denial of rehearing en banc. She wrote to urge any future court that interprets EPCA not to repeat the panel opinion's mistakes. She wrote that EPCA's history, text, and structure all show that the Berkeley ordinance is not preempted because it does not affect "energy use" within the meaning of the statute.

Respecting the denial of rehearing en banc, Judge Berzon, joined by Judges Paez and W. Fletcher, agreed with Judge Friedland's dissent from the denial of rehearing en banc.

---

### COUNSEL

Brian C. Baran (argued), Reichman Jorgensen Lehman & Feldberg LLP, Washington, D.C.; Courtland L. Reichman, Laura Carwile, Ariel C. Green Anaba, and Sarah Jorgensen, Reichman Jorgensen Lehman & Feldberg LLP, Redwood Shores, California; Kylie C. Kim, Massey & Gail LLP, Washington, D.C.; Gary J. Toman, Weinberg Wheeler Hudgins Gunn & Dial, Atlanta, Georgia; for Plaintiff-Appellant.

Anthony L. Francois (argued) and Peter S. Prows, Briscoe Ivester & Bazel LLP, San Francisco, California; Sean H. Donahue, Donahue Goldberg & Weaver LLP, Washington, D.C.; Brendan Darrow, Rent Stabilization Board, Berkeley, California; Farima F. Brown, City Attorney, Berkeley Office of the City Attorney, Berkeley, California; for Defendant-Appellee.

Angelo I. Amador, Restaurant Law Center, Washington, D.C., for Amicus Curiae Restaurant Law Center.

Thomas G. Pulham (argued), Deputy Attorney General; Michael S. Raab, H. Thomas Byron, III, and Joseph F. Busa, Appellate Staff Attorneys, Civil Division; Stephanie Hinds, Acting United States Attorney; Ismail J. Ramsey, United States Attorney; Brian M. Boynton, Principal Deputy Assistant Attorney General; United States Department of Justice, Washington, D.C.; Emily Hammond, Deputy General Counsel for Litigation, Regulation, and Enforcement; Alexandra Klass, Deputy General Counsel for Energy Efficiency and Clean Energy Demonstrations; Brent Allen, Deputy General Counsel for Environment and Litigation; United States Department of Energy, Washington, D.C.; Samuel T. Walsh, General Counsel; for Amicus Curiae USA.

Michael L. Murray and Matthew J. Agen, American Gas Association, Washington, D.C., for Amicus Curiae American Gas Association.

Megan Berge, Baker Botts LLP, San Francisco, California; JoAnna Adkisson, Baker Botts LLP, Washington, D.C.; Francesca Eick, Baker Botts LLP, Austin, Texas; for Amici Curiae Air Conditioning, Heating, and Refrigeration Institute; California Building Industry Association, Hearth, Patio, & Barbecue Association; National Association of Home Builders; and National Association of Manufacturers.

Michael Burger, Jennifer Danis, and Amy E. Turner, Sabin Center for Climate Change Law, New York, New York, for Amici Curiae National League of Cities; League of California Cities; and California State Association of Counties.

Theodore A.B. McCombs, Jonathan A. Wiener, M. Elaine Meckenstock, and Somerset Perry, Deputy Attorneys General; David A. Zonana and Myung J. Park, Supervising

Deputy Attorneys General; Edward H. Ochoa and Robert W. Byrne, Senior Assistant Attorneys General; Rob Bonta, California Attorney General; California Attorney General's Office, San Diego, California; Brian E. Frosh, Maryland Attorney General, Maryland Attorney General's Office, Baltimore, Maryland; Andrew J. Bruck, Acting New Jersey Attorney General, New Jersey Attorney General's Office, Trenton, New Jersey; Letitia James, New York Attorney General, New York Attorney General's Office, New York, New York; Robert W. Ferguson, Washington Attorney General, Washington Attorney General's Office, Seattle, Washington; Georgia Pestana, Corporation Counsel, City of New York, New York, New York; Maura Healey, Commonwealth of Massachusetts Attorney General, Commonwealth of Massachusetts Attorney General's Office, Boston, Massachusetts; Hector Balderas, New Mexico Attorney General, New Mexico Attorney General's Office, Santa Fe, New Mexico; for Amici Curiae the states of California, Maryland, New York, New Jersey, New Mexico, New York, Oregon, and Washington, The Commonwealth of Massachusetts, The District of Columbia, and the City of New York.

Regina J. Hsu, Earthjustice, San Francisco, California; Timothy R. Oberleiton, Earthjustice, Washington, D.C.; for Amici Curiae Climate Health Now, San Francisco Bay Physicians for Social Responsibility, Physicians for Social Responsibility & American Thoracic Society.

Daniel N. Carpenter-Gold, Cara A. Horowitz, and Julia E. Stein, Frank G. Wells Environmental Law Clinic, UCLA School of Law, Los Angeles, California, for Amici Curiae Energy and Environmental Law Professors.

Kimberley E. Leefatt, Natural Resources Defense Council, Santa Monica, California; Thomas Zimpleman, Natural Resources Defense Council, Washington, D.C.; for Amici Curiae Chef Christopher Galarza and Chef Gerard Kenny II.

Gloria D. Smith, Sierra Club, Oakland California, for Amicus Curiae Sierra Club.

Daniel J. Becker, Assistant Counsel; John J. Sipos, Deputy General Counsel & Solicitor; New York Public Service Commission, Office of General Counsel, Albany, New York; for Amicus Curiae New York State Public Service Commission.

Nathaniel R. Mattison, Guarini Center on Environmental, Energy and Land Use Law, New York, New York, for Amicus Curiae Guarini Center on Environmental, Energy and Land Use Law at New York University School of Law.

---

## ORDER

The opinion, Judge O'Scannlain's concurrence, and Judge Baker's concurrence filed on April 17, 2023, and published at 65 F.4th 1045 (9th Cir. 2023), are amended by the opinion and respective concurrences filed concurrently with this order.

Appellants filed a petition for rehearing en banc, Docket No. 92. Judge Bumatay voted to deny the petition for rehearing en banc and Judge O'Scannlain and Judge Baker so recommended.

The full court was advised of the petition for rehearing en banc. A judge of the court requested a vote on whether to rehear the matter en banc. The matter failed to receive a

majority of the votes of the non-recused active judges in favor of en banc consideration. Fed. R. App. P. 35. The petition for rehearing en banc is DENIED. No further petitions for rehearing en banc will be considered. Judge H.A. Thomas did not participate in the deliberations or vote in this case.

---

## OPINION

BUMATAY, Circuit Judge:

By completely prohibiting the installation of natural gas piping within newly constructed buildings, the City of Berkeley has waded into a domain preempted by Congress. The Energy Policy and Conservation Act (“EPCA”), 42 U.S.C. § 6297(c), expressly preempts State and local regulations concerning the energy use of many natural gas appliances, including those used in household and restaurant kitchens. Instead of directly banning those appliances in new buildings, Berkeley took a more circuitous route to the same result. It enacted a building code that prohibits natural gas *piping* in those buildings from the point of delivery at a gas meter, rendering the gas appliances useless.

The California Restaurant Association, whose members include restaurateurs and chefs, challenged Berkeley’s regulation, raising an EPCA preemption claim. The district court dismissed the suit. In doing so, it limited the Act’s preemptive scope to ordinances that facially or directly regulate covered appliances. But such limits do not appear in EPCA’s text. By its plain text and structure, EPCA’s preemption provision also encompasses building codes concerning the energy use of covered products. And thus



EPCA preempts Berkeley's building code because it prohibits natural gas piping in new construction buildings from the point of delivery at the gas meter.

We thus conclude that EPCA preempts Berkeley's building code's effect against covered products and reverse.

### I.

In July 2019, the Council of the City of Berkeley, California, adopted Ordinance No. 7,672-N.S.—“Prohibition of Natural Gas Infrastructure in New Buildings” (“Ordinance”). As its name implies, the Ordinance prohibits, with some exceptions, “Natural Gas Infrastructure” in “Newly Constructed Buildings” in the City of Berkeley. Berkeley Mun. Code (“BMC”) § 12.80.040(A). “Natural Gas Infrastructure” is defined as “fuel gas piping, other than service pipe, in or in connection with a building, structure or within the property lines of premises, extending from the point of delivery at the gas meter as specified in the California Mechanical Code and Plumbing Code.” *Id.* § 12.80.030(E). And “Newly Constructed Building” refers to “a building that has never before been used or occupied for any purpose.” *Id.* § 12.80.030(F). These building codes “apply to Use Permit or Zoning Certificate applications” submitted after the Ordinance’s January 1, 2020, effective date. *Id.* §§ 12.80.020(A), 12.80.080.

The Ordinance seeks to “eliminate obsolete natural gas infrastructure and associated greenhouse gas emissions in new buildings where all-electric infrastructure can be most practicably integrated, thereby reducing the environmental and health hazards produced by the consumption and transportation of natural gas.” *Id.* § 12.80.010(H). By its own terms, the Ordinance “shall in no way be construed . . .

as requiring the use or installation of any specific appliance or system as a condition of approval.” *Id.* § 12.80.020(C). The Ordinance also exempts a new construction from its prohibition if it is in the “public interest” or if it is “not physically feasible.” *Id.* §§ 12.80.040(A), 12.80.050.

In November 2019, the Association sued the City of Berkeley, claiming that EPCA and state law preempted the Ordinance. After the City moved to dismiss under Federal Rule of Civil Procedure 12(b)(6), the district court dismissed the EPCA claim. It concluded that EPCA must be “interpreted in a limited manner,” so that the Act doesn’t “sweep into areas that are historically the province of state and local regulation.” *Cal. Rest. Ass’n v. City of Berkeley*, 547 F. Supp. 3d 878, 891 (N.D. Cal. 2021). Because the Ordinance does “not facially regulate or mandate any particular type of product or appliance” and because its impact is “*at best* indirect[]” on consumer products, the district court ruled that EPCA does not preempt the Ordinance. *Id.* It then declined to exercise supplemental jurisdiction and dismissed the state-law claims. *Id.*

The Association timely appealed, and we review *de novo*. *Air Conditioning & Refrigeration Inst. v. Energy Res. Conservation & Dev. Comm’n*, 410 F.3d 492, 495 (9th Cir. 2005).

## II.

Before jumping to the merits of this case, we must first assure ourselves of the Association’s Article III standing. To satisfy associational standing requirements, an organization must demonstrate that (1) at least one of its members has suffered an injury in fact that is (a) concrete and particularized and (b) actual or imminent, rather than conjectural or hypothetical; (2) the injury is fairly traceable

to the challenged action; and (3) it is likely, not merely speculative, that the injury will be redressed by a favorable decision. *Nat. Res. Def. Council v. EPA*, 735 F.3d 873, 878 (9th Cir. 2013). Berkeley contends that the Association lacks standing because it failed to establish that the Ordinance would imminently harm its members. We disagree.

When “standing is challenged on the basis of the pleadings,” we must “accept as true all material allegations of the complaint” and “construe the complaint in favor of the complaining party.” *Pennell v. City of San Jose*, 485 U.S. 1, 7 (1988) (simplified). At this stage, “general factual allegations of injury resulting from the defendant’s conduct may suffice, for on a motion to dismiss we presume that general allegations embrace those specific facts that are necessary to support the claim.” *Lujan v. Defs. of Wildlife*, 504 U.S. 555, 561 (1992) (simplified).

In its complaint, the Association explains that restaurants rely on natural gas for preparing certain foods and that many chefs are trained only on natural gas stoves. The Association’s members include restaurateurs and chefs who do business or seek to do business in Berkeley. And the Association alleges that one or more of its members would like to open or relocate a restaurant in a new Berkeley building completed after the Ordinance became effective on January 1, 2020. But those members could not do so because of the Ordinance’s ban on natural gas. The City contends these allegations don’t establish standing because they don’t allege “*how soon*” in the future an Association member would open or relocate a restaurant.

To establish “actual or imminent” injury, the Association must show a “credible threat that a probabilistic harm will

materialize.” *Nat. Res. Def. Council*, 735 F.3d at 878 (simplified). The goal of this requirement is “to ensure that the concept of ‘actual or imminent’ harm is not stretched beyond its purpose, which is to ensure that the alleged injury is not too speculative for Article III purposes.” *Id.* (simplified). In *Natural Resources Defense Council*, we held that it was enough that the government’s action “increases the threat of future harm to [the organization’s] members.” *Id.* In that case, the imminence prong was satisfied when the Environmental Protection Agency’s conditional registration of two pesticides would “increase[] the odds of exposure” for the organization’s members’ children. *Id.*

Given our precedent, the Association has easily established standing. The Association has alleged that its members would open or relocate a restaurant in a new building in Berkeley but for the City’s ban on natural gas. Thus, because of the Ordinance, the Association’s members cannot open a restaurant in any new Berkeley building and use natural gas appliances. That poses a “credible threat” of a “probabilistic harm,” even if the Association hasn’t provided a date certain for any restaurant’s opening night.

We now turn to the merits of this challenge.

### III.

At issue here is the scope of EPCA’s preemption clause. Berkeley argues that EPCA preemption only covers regulations that impose standards on the design and manufacture of appliances, not regulations that impact the distribution and availability of energy sources like natural gas. The federal government, as amicus, offers a slightly different take. It contends that EPCA only preempts “energy conservation standards” that operate directly on the covered

products themselves. The Association disagrees with both. It believes that EPCA preemption extends to regulations, like Berkeley's building code, that effectively ban covered products from using available energy sources.

As with any express preemption case, our focus is on the plain meaning of the preemption provision. *See Puerto Rico v. Franklin Cal. Tax-Free Tr.*, 579 U.S. 115, 125 (2016). That's because "the plain wording of the clause . . . necessarily contains the best evidence of Congress' preemptive intent." *Id.* In discerning its meaning, we look to EPCA's text, structure, and context. *See R.J. Reynolds Tobacco Co. v. Cnty. of Los Angeles*, 29 F.4th 542, 552 (9th Cir. 2022). And we apply this textual analysis "without any presumptive thumb on the scale" for or against preemption. *Id.* at 553 n.6.

Based on its text, structure, and context, we conclude EPCA preempts building codes like Berkeley's Ordinance that ban natural gas piping within new buildings. Our holding here is limited. We conclude only that EPCA applies to building codes and that Berkeley's Ordinance falls within the Act's preemptive scope.

#### A.

EPCA's preemption clause establishes that, once a federal energy conservation standard becomes effective for a covered product, "no State regulation concerning the energy efficiency, energy use, or water use of such covered product shall be effective with respect to such product," unless the regulation meets one of several categories not relevant here. 42 U.S.C. § 6297(c). For our purposes, we need to determine what constitutes a "regulation concerning the . . . energy use" of a covered product.

Of critical importance here is that the structure of the statute indicates that “a regulation concerning the . . . energy use” can include “building code requirements.” § 6297(f) (heading). “A regulation . . . that is contained in a *State or local building code for new construction* concerning the energy efficiency or energy use of a covered product” is superseded by EPCA *unless* it complies with various requirements. § 6297(f)(1)–(3) (emphasis added).<sup>1</sup> So subsection (f) demonstrates that EPCA’s preemptive scope extends beyond direct or facial regulations of covered products to at least include building codes “concerning the energy . . . use” of such products.

To ascertain what Congress meant by “energy use,” we turn to the statutory definitions. EPCA defines “energy use” as “the quantity of energy directly consumed by a consumer product at point of use.” § 6291(4).<sup>2</sup> “[E]nergy” refers to “electricity” or “fossil fuels,” such as natural gas. § 6291(3). A “consumer product” is “any article” which “consumes, or is designed to consume,” energy or water and is distributed for personal use. § 6291(1). The preemption clause applies to any “covered product,” which is defined as certain “consumer products,” like refrigerators, dishwashers, and kitchen ovens. §§ 6291(2), 6292.<sup>3</sup> And as a matter of ordinary meaning, “point of use” means the “place where

---

<sup>1</sup> It’s undisputed here that Berkeley’s Ordinance does not comply with these requirements.

<sup>2</sup> Unless otherwise indicated, all section (§) citations refer to Title 42 of the U.S. Code.

<sup>3</sup> The preemption clause also applies to “industrial equipment,” which includes commercial equipment that may be used in restaurants. *See* §§ 6311(1), 6316(a).

something is used.” Oxford English Dictionary Online (2022).

So putting these terms together, EPCA preempts regulations, including “building code requirements,” § 6297(f), that relate to “the quantity of [natural gas] directly consumed by” certain consumer appliances at the place where those products are used. Right off the bat, we know that EPCA is concerned with the end-user’s ability to *use* installed covered products at their intended final destinations, like restaurants. After all, a building code that prohibits consumers from using natural gas-powered appliances in newly constructed buildings necessarily regulates the “quantity of energy directly consumed by [the appliances] at point of use.” So, by its plain language, EPCA preempts Berkeley’s regulation here because it prohibits the installation of necessary natural gas infrastructure on premises where covered appliances are used.

Berkeley’s main contention is that its Ordinance doesn’t regulate “energy use” because it bans natural gas rather than prescribes an affirmative “quantity of energy.” While Berkeley concedes that a prohibition on natural gas infrastructure reduces the energy consumed by natural gas appliances in new buildings to “zero,” it argues that “zero” is not a “quantity” and so the Ordinance is not an “energy use” regulation. But that defies the ordinary meaning of “quantity.” In context, “quantity” means “a property or attribute that can be expressed in numerical terms.” Oxford

English Dictionary Online (2022). And it is well accepted in ordinary usage that “zero” is a “quantity.”<sup>4</sup>

Equally unavailing is Berkeley’s argument that EPCA’s definition of “energy efficiency” precludes a total prohibition on natural gas piping from being an “energy use” regulation. EPCA defines “energy efficiency” as the “ratio of useful output of services . . . to the energy use” of the product. § 6291(5). According to Berkeley, “zero” cannot serve as the “quantity of energy” in “energy use”; otherwise, the “energy efficiency” ratio would have an impermissible “zero” denominator. But in that case, both the denominator (“energy use”) and the numerator (“output”) would be zero—which simply yields an indeterminate result.<sup>5</sup> And

---

<sup>4</sup> See, e.g., *SolarWorld Ams., Inc. v. United States*, 962 F.3d 1351, 1359 (Fed. Cir. 2020) (import data recorded “a quantity of zero”); *United States v. Everett*, 601 F.3d 484, 493 (6th Cir. 2010) (referring to “zero” as an “arbitrary quantity of time”); see also 85 Fed. Reg. 22,641 (discussing “a quantity of zero blocks” in an auction context). Even children, bees, and crows apparently understand that “zero” is a numerical quantity. See Ellen Bialystok & Judith Codd, *Representing Quantity Beyond Whole Numbers: Some, None, and Part*, 54 Can. J. Experimental Psych. 117–28 (2000) (showing children aged three to seven could work with “quantities” including “whole numbers” and “zeros”); see also Katie Spalding, *Crows Once Again Prove Their Intelligence By Showing That They Understand Zero*, IFL Science (June 17, 2021) (citing evidence that honeybees and crows can “understand zero as a numerical quantity—as ‘something’ rather than ‘nothing’”). Same goes for the scientific community. See, e.g., A.S. Kompaneyets, *Theoretical Physics* 377 (2d 2013) (“[T]he shift of an energy level is equal to the average of the perturbation energy for unperturbed motion . . . . But it is easy to see that the average of this quantity is equal to zero.”).

<sup>5</sup> In math, an “indeterminate” expression is “unknown or variable,” “not definitively or precisely determined.” See Eric Weisstein, *Indeterminate*, WOLFRAM MATHWORLD, <https://perma.cc/2PD6-5ZZK>.



we doubt that Congress meant to hide an exemption to the plain text of EPCA's preemption clause in a mathematical equation.

Thus, a building code regulation that imposes a total ban on natural gas is not exempt from EPCA just because it lowers the "quantity of energy" consumed to "zero." In other words, a regulation on "energy use" fairly encompasses an ordinance that effectively eliminates the "use" of an energy source. As the Court said long ago, a regulation may "assume the form of [a] prohibition." *Champion v. Ames*, 188 U.S. 321, 328 (1903).

And as a textual matter, EPCA preemption is not limited to facial regulations of consumer products as the district court held. Although the district court recognized EPCA's "broad" reach, it limited preemption to regulations that "directly regulate either the energy use or energy efficiency of covered appliances." *Cal. Rest. Ass'n*, 547 F. Supp. 3d at 891. It thus cabined preemption to regulations that "facially . . . mandate or require a[] particular energy use of a covered product." *Id.* Such a reading is divorced from the statute's text. It first ignores that "energy use" is based on consumption that happens "at point of use." § 6291(4). This means that we measure energy use not only from where the products roll off the factory floor, but also from where consumers *use* the products. Put simply, by enacting EPCA, Congress ensured that States and localities could not prevent consumers from using covered products in their homes, kitchens, and businesses. So EPCA preemption extends to regulations that address the products themselves *and* building codes that concern their *use* of natural gas.

To erase any doubt, rather than limit preemption to facial regulations of products, Congress expressly expanded

EPCA’s reach to regulations that “concern[]” such products. § 6297(c). The Supreme Court has explained that “[c]oncerning’ means ‘relating to,’ and is the equivalent of ‘regarding, respecting, about.’” *Lamar, Archer & Cofrin, LLP v. Appling*, 138 S. Ct. 1752, 1759 (2018) (simplified). In the legal context, this has “a broadening effect, ensuring that the scope of a provision covers not only its subject but also matters relating to that subject.” *Id.* at 1760. We thus read the term “expansively” and, as a matter of ordinary meaning, a regulation may “concern” something without directly regulating that thing. *Cf. Morales v. Trans World Airlines, Inc.*, 504 U.S. 374, 378–90 (1992) (holding that the Airline Deregulation Act, which prohibits States from enforcing any law “relating to rates, routes, or services” of any air carrier, preempted fare-advertising guidelines that “would have a significant impact upon” the airlines’ ability to charge fares). At a minimum then, by using the term “concerning,” Congress meant to expand preemption beyond direct or facial regulations of covered appliances. And a building code that bans the installation of piping that transports natural gas from a utility’s meter on the premises to products that operate on such gas “concerns” the energy use of those products as much as a direct ban on the products themselves.

Yet, the breadth of EPCA’s preemption provision “does not mean the sky is the limit.” *Dan’s City Used Cars, Inc. v. Pelkey*, 569 U.S. 251, 260 (2013). Though EPCA’s preemption provision is broad, it is not unlimited. For instance, our holding here has nothing to say about a State or local government regulation of a utility’s distribution of natural gas to premises where covered products might be used. We only decide that EPCA’s preemptive scope applies

to building codes that regulate the gas usage of covered appliances on premises where gas is otherwise available.

Finally, EPCA's waiver provision likewise shows the extensive scope of the preemption clause. EPCA permits the federal government to waive preemption if a State shows that a proposed regulation is needed to meet "unusual and compelling State or local energy[] interests." § 6297(d)(1)(B)–(C). But it stops the federal government from waiving preemption if the "State regulation will significantly burden manufacturing, marketing, distribution, sale, or servicing of the covered product on a national basis." § 6297(d)(3). So the federal government must consider the complete lifecycle of an appliance—from manufacturing to servicing—in reviewing a waiver petition. Such a provision would make little sense if the scope of EPCA's preemption ends with the design or manufacture of the product. A burden on "servicing," for example, may implicate regulation of the installation and use of the product—like Berkeley's building code. And no doubt Berkeley's ban, if adopted by States and localities throughout the country, would "significantly burden" the "sale" of covered products "on a national basis." *Id.*

## B.

The Government offers slightly different textual arguments. It contends that EPCA only preempts "energy conservation standards" that operate directly on covered products themselves. To justify its position, the Government first latches onto EPCA's language stating that a state regulation concerning the energy use of a covered product is not "effective with respect to such product." § 6297(c). The Government contends that this language limits EPCA's

preemptive scope to only direct regulations on covered products.<sup>6</sup>

But the Government’s textual analysis is wrong. The phrase the Government highlights simply limits EPCA’s preemption to a regulation’s *effect* on covered products—it doesn’t say that the regulation must be *on* the covered products. To illustrate, think of EPCA’s preemption clause as a conditional sentence: If a “regulation concern[s] . . . [the] energy use . . . of [a] covered product,” then it is preempted “with respect to such product.” The latter clause doesn’t modify the meaning of the former.

To put it more concretely: Say a State enacts a broad regulation on all appliances—some that are “covered” and some that are not. EPCA would only supersede the regulation’s impact on the covered products. And the State could still enforce its regulation against the non-covered products. In other words, if a building code concerns the

---

<sup>6</sup> We note that the Government’s position hasn’t always been that EPCA preempts only direct regulations on covered products. When interpreting the 1978 version of EPCA, the Government concluded that the Act would preempt regulations of energy infrastructure, like building codes. The Government warned that “[s]tandards subject to preemption would include standards for any particular type (or class) of covered products established by *mandatory State or local building codes*.” 47 Fed. Reg. 57,198, 57,215 (Dec. 22, 1982) (emphasis added). Even more to the point, the Government advised that a “[p]rohibition of hook-ups for appliances with less than a certain efficiency would be subject to preemption.” *Id.* So back in 1982, the Government acknowledged that EPCA would supersede building codes dealing with energy requirements for “hook-ups for appliances.” And the Government maintained this position when EPCA’s preemption provision was narrower than today. *See* § 6297(a)(2) (1978) (superseding any state regulation that provides for “any energy efficiency standards or other requirement with respect to energy efficiency or energy use of a covered product”).

“energy use” of covered and non-covered products alike, EPCA’s preemptive effect is limited to the covered products. Here, Berkeley may enforce its building code on non-covered products, but EPCA displaces its effect on covered products.<sup>7</sup> But this language in no way narrows a “regulation concerning the . . . energy use” to direct regulations on covered products themselves.

The Government next argues that EPCA preemption only acts on regulations that are the equivalent of “energy conservation standards.” For this, the Government relies on the title of EPCA’s preemption provision. Section 6297(c) is entitled, “General rule of preemption for energy conservation standards when Federal standard becomes effective for product.” Based on this heading, the Government contends that “regulation[s] concerning energy efficiency [or] energy use” in EPCA’s operative preemption clause should be construed to mean only state regulations that function as “energy conservation standards.” But there are three problems with this argument.

First, § 6297(c)’s heading cannot supersede its plain text. While the “title of a statute” may help clarify an ambiguous word or phrase, it “cannot limit the plain meaning of the text.” *Pa. Dep’t of Corr. v. Yeskey*, 524 U.S. 206, 212 (1998) (simplified). The Government hasn’t identified enough ambiguity in the preemption clause for the subsection’s title to provide much interpretive guidance.

Second, Congress gave “energy use,” “energy efficiency,” and “energy conservation standards” related,

---

<sup>7</sup> We thus disagree with the Association’s assertion that EPCA preempts the Ordinance “as a whole.” Rather, when it comes to the Ordinance’s effect on non-covered products, EPCA has no impact.

but different, meanings. Recall that “energy use” is defined as “the quantity of energy directly consumed by a consumer product at point of use.” § 6291(4). At the same time, EPCA defines “energy efficiency” as the “ratio of the useful output of services from a consumer product to the energy use of such product.” § 6291(5). And finally, an “energy conservation standard” is generally “a performance standard which prescribes a minimum level of energy efficiency or a maximum quantity of energy use.” § 6291(6)(A). So for EPCA purposes, these terms are closely related, but not identical.

And third, elsewhere EPCA uses both phrases *together*—which shows that they aren’t simply interchangeable. For example, EPCA allows the federal government to waive preemption for a regulation “which provides for any energy conservation standard or other requirement with respect to energy use, energy efficiency, or water use.” § 6297(d)(1)(A). If “energy use” means “energy conservation standards” as the Government argues, this provision would create redundancy in the statutory text. Rather, by placing them in a list like this, Congress intended the phrases to be related, but distinct, concepts.

EPCA’s operative preemptive text is thus not limited to “energy conservation standards” as the Government would like us to hold. While EPCA’s preemptive effect is triggered by federal enactment of an energy “performance standard” on a covered product, the statute then broadly preempts any state regulation concerning “energy use” and “energy efficiency” of the covered product. §§ 6291(6)(A), 6297(c). At bottom, the Government argues that we should supplant “energy use” and “energy efficiency” and replace those terms with “energy conservation standards.” But we presume that Congress means what it says, and we can’t

simply reconfigure the statute to fit the Government's needs. Indeed, after Congress has taken pains to define each phrase separately, it would be inappropriate for courts to disregard these nuances and treat the phrases as interchangeable.

### C.

We next address Berkeley's non-textual arguments.

Berkeley first argues that finding this specific building code is preempted by EPCA would impliedly repeal the Natural Gas Act, 15 U.S.C. § 717 et seq. We disagree. This is a narrow opinion about Berkeley's building codes. The Natural Gas Act "create[s] a comprehensive and effective regulatory scheme of dual state and federal authority" over the wholesale of natural gas. *S. Coast Air Quality Mgmt. Dist. v. FERC*, 621 F.3d 1085, 1090 (9th Cir. 2010). It does so by granting the Federal Energy Regulatory Commission ("FERC") "exclusive jurisdiction" over three areas: the "transportation of natural gas in interstate commerce," the "sale in interstate commerce of natural gas for resale," and "natural-gas companies engaged in such transportation or sale." *Id.* (quoting 15 U.S.C. § 717(b)). But the Natural Gas Act "specifically exempted from" FERC regulation "the 'local distribution of natural gas.'" *Id.* (quoting 15 U.S.C. § 717(b)).

By its terms, then, the Natural Gas Act only prevents FERC from regulating the local distribution of gas. So as a textual matter, the Natural Gas Act's restriction on FERC authority doesn't conflict with Congress, through EPCA, deciding to supplant building codes that prevent the operation of natural gas appliances. Thus, there's nothing irreconcilable about the scope of EPCA's preemption provision and the Natural Gas Act. We see no implied repeal problem because the Ordinance doesn't prevent a utility's

distribution of natural gas *to* the meter at new buildings—rather, it prevents the use of covered appliances by banning piping *within* the building *from* a meter to an appliance. *See* BMC § 12.80.030(E) (defining prohibited “natural gas infrastructure” as “fuel gas piping, other than service pipe, in or in connection with a building, structure or within the property lines of premises, extending *from* the point of delivery at the gas meter as specified in the California Mechanical Code and Plumbing Code”) (emphasis added). When gas arrives at a meter, it has been delivered to the user. Rather than interfering with distribution of natural gas, the Ordinance prevents a building occupant from *using* available gas to run a covered appliance.

Berkeley finally contends that preemption here would mean that the City must affirmatively make natural gas available everywhere. That does not follow from our limited decision today. We only hold that EPCA prevents Berkeley from prohibiting new-building owners from “extending” fuel gas piping within their buildings “from the point of delivery at the gas meter” by way of a building code. *See* BMC § 12.80.030(E). Our holding is very narrow—it doesn’t touch on whether the City has any obligation to maintain or expand the availability of a utility’s delivery of gas to meters.

#### D.

Berkeley and the Government ask us to make interpretive moves similar to those that the Supreme Court rejected in *Engine Manufacturers Association v. South Coast Air Quality Management District*, 541 U.S. 246 (2004). In that case, our court had interpreted the Clean Air Act, which prohibits States from enforcing any standard “relating to the control of emissions from new motor



vehicles,” as not preempting a local ordinance that prevented fleet operators from purchasing or leasing vehicles that did not comply with the local emissions standards. *Id.* at 252. In short, our court “engraft[ed]” a “limiting component” onto the statute which narrowed the Clean Air Act’s preemptive reach to standards on manufacturers, rather than purchasers. *Id.* at 253. But the Supreme Court rejected our approach and emphasized that “[t]he manufacturer’s right to sell federally approved vehicles is meaningless in the absence of a purchaser’s right to buy them.” *Id.* at 255.

Other Supreme Court cases teach the same lesson. *See Nat’l Meat Ass’n v. Harris*, 565 U.S. 452, 458 (2012) (holding that the Federal Meat Inspection Act, which prohibits States from imposing requirements “with respect to [livestock] premises, facilities and operations,” preempted a California regulation that placed additional requirements on the *sale* of meat); *Am. Trucking Ass’ns v. City of Los Angeles*, 569 U.S. 641, 652 (2013) (criticizing State efforts to “avoid preemption by shifting their regulatory focus” to different companies within the same supply chain because it did not “make[] any difference” that the State chose “an indirect but wholly effective means” of achieving a preempted goal); *Rowe v. N.H. Motor Transp. Ass’n*, 552 U.S. 364, 372 (2008) (finding state law that was “less direct than it might be” nevertheless preempted because it “produce[d] the very effect that the federal law sought to avoid”).

As these cases make clear, States and localities can’t skirt the text of broad preemption provisions by doing *indirectly* what Congress says they can’t do *directly*. EPCA would no doubt preempt an ordinance that directly prohibits the use of covered natural gas appliances in new buildings. So Berkeley can’t evade preemption by merely moving up

one step in the energy chain and banning natural gas piping within those buildings. Otherwise, the ability to use covered products is “meaningless” if consumers can’t access the natural gas available at the meter on the premises. *See Engine Mfrs. Ass’n*, 541 U.S. at 255.

#### IV.

In sum, Berkeley can’t bypass EPCA’s preemption of building codes that directly ban covered products by instead simply prohibiting the piping that transports natural gas from the utility’s meter to the appliance. EPCA thus preempts the Ordinance’s effect on covered products. We therefore reverse and remand for proceedings consistent with this opinion. On remand, the district court must also reinstate the Association’s state-law claims.

---

O’SANNLAIN, Circuit Judge, concurring:

I agree that EPCA preempts the Ordinance. But I only reach that conclusion because, under Ninth Circuit precedent, I believe I am bound to hold that the presumption against preemption does *not* apply to the express-preemption provision before us today. That conclusion is neither obvious nor easy. In my view, this issue presents a challenging question in a deeply troubled area of law—namely, which of the apparently conflicting lines of cases we should follow in applying the presumption against preemption in express-preemption cases.

At first glance, one might have thought this issue was already resolved by our decision in *Air Conditioning & Refrigeration Inst. v. Energy Res. Conservation & Dev. Comm’n*, 410 F.3d 492 (9th Cir. 2005). There, like here, we

were called upon to assess a set of express-preemption provisions in EPCA. *Id.* at 495 (interpreting 42 U.S.C. §§ 6297(a), 6316(a)-(b)). We followed Supreme Court precedent and applied the Supreme-Court-mandated “presumption against preemption” to interpret the EPCA preemption provisions “narrow[ly].” *Id.* at 496 (applying *Medtronic, Inc. v. Lohr*, 518 U.S. 470, 485 (1996)). Our decision in *Air Conditioning* was no outlier. The Supreme Court consistently instructed us to apply the presumption in express-preemption cases, at least in areas of traditional state concern—and we consistently followed these instructions. *Sprint Telephony PCS, L.P. v. County of San Diego*, 543 F.3d 571, 578 (9th Cir. 2008) (en banc) (confirming *Air Conditioning*’s approach).

But things are, unfortunately, not so simple today. In its recent *Franklin* decision, the Supreme Court stated that “because the statute contains an express pre-emption clause, we do not invoke any presumption against preemption.” *Puerto Rico v. Franklin Cal. Tax-Free Tr.*, 579 U.S. 115, 125 (2016) (cleaned up). The Court did not mention—much less expressly overrule—the decades of cases where the presumption had indeed been applied in like circumstances. And the Court did not, respectfully, provide much discussion of its decision not to apply the presumption. Instead, after the Court stated it would “not invoke” the presumption, it explained that it would “focus on the plain wording of the clause,” which is “where the inquiry should end, for the statute’s language is plain.” *Id.* (cleaned up).

What to make of *Franklin*’s “drive-by ruling” is challenging. *Whitman v. United States*, 574 U.S. 1003 (2014) (Scalia, J., statement respecting denial of certiorari). We do not assume that the Court has overruled its older precedents “by implication.” *Agostini v. Felton*, 521 U.S.

203, 237 (1997). And we do not easily assume that the Court has abrogated our circuit precedents unless the decisions are “clearly irreconcilable,” particularly where the Supreme Court decisions we relied on remain on the books. *Miller v. Gammie*, 335 F.3d 889, 900 (9th Cir. 2003). Nevertheless, our circuit—without hesitating to consider *Franklin*’s limits or the possibility of reconciling *Franklin* with existing precedent—has broadly read *Franklin* categorically to prohibit applying the presumption to express-preemption provisions in future cases. *See, e.g., R.J. Reynolds Tobacco Co. v. County of Los Angeles*, 29 F.4th 542, 553 n.6 (9th Cir. 2022). Under these post-*Franklin* decisions, *Air Conditioning* no longer seems to govern here—and the presumption does not apply.

Respectfully, I have my doubts. As an inferior-court judge—bound to respect Supreme Court and Ninth Circuit precedent—I have great difficulty in deciding how to read the Supreme Court’s instructions here. *See, e.g., Air Evac EMS, Inc. v. Cheatham*, 910 F.3d 751, 762 n.1 (4th Cir. 2018) (Wilkinson, J.) (noting the Supreme Court’s “somewhat varying pronouncements on presumptions in express preemption cases”). And I am not alone—circuits are split on this issue. *Dialysis Newco, Inc. v. Cmty. Health Sys. Grp. Health Plan*, 938 F.3d 246, 258 (5th Cir. 2019) (collecting circuit split). While I ultimately conclude that, under this court’s cases, the presumption does not apply here, the law remains troubling and confused—beset by tensions in Supreme Court precedents, disagreement among the circuits, and important practical questions still unanswered. I write separately to indicate the need for further guidance.

## I

## A

The application of the presumption against preemption to express-preemption provisions has always raised hard questions. But at least after the Supreme Court’s decision in *Cipollone*, the rule was clear: the presumption applies even to express-preemption provisions, at least in areas of traditional state concern. *See, e.g., Cipollone v. Liggett Grp., Inc.*, 505 U.S. 504, 518 (1992); *Medtronic*, 518 U.S. at 485. Under this framework, we were instructed to interpret express-preemption provisions “narrow[ly]” in light of “two presumptions about the nature of preemption.” *Medtronic*, 518 U.S. at 485. First, “the historic police powers of the States were not to be superseded by the Federal Act unless that was the clear and manifest purpose of Congress.” *Id.* (cleaned up). Second, “any understanding of the scope of a preemption statute must rest primarily on a fair understanding of congressional purpose,” which is “primarily” discerned from statutory text but also informed by “the structure and purpose of the statute as a whole.” *Id.* at 485-86 (cleaned up).

This approach, to be sure, invited criticism early on. *See, e.g., Cipollone*, 505 U.S. at 544–48 (Scalia, J., concurring and dissenting in part) (explaining that “our job is to interpret Congress’s decrees of pre-emption neither narrowly nor broadly, but in accordance with their apparent meaning”); Caleb Nelson, *Preemption*, 86 Va. L. Rev. 225, 291 n.205, 292–303 (2000) (arguing that “courts should not give artificially crabbed constructions to preemption clauses”). Despite these objections, the Supreme Court continued to apply the presumption to express-preemption provisions over the years. *See, e.g., Cipollone*, 505 U.S. at 518; *N.Y.*

*State Conference of Blue Cross & Blue Shield Plans v. Travelers Ins. Co.*, 514 U.S. 645, 654 (1995); *Medtronic*, 518 U.S. at 485; *De Buono v. NYSA-ILA Med. & Clinical Servs. Fund*, 520 U.S. 806, 814 (1997); *Bates v. Dow Agrosciences, LLC*, 544 U.S. 431, 449 (2005); *CTS Corp. v. Waldburger*, 573 U.S. 1, 18–19 (2014); *but see Mutual Pharm. Co. v. Bartlett*, 570 U.S. 472 (2013) (applying preemption but declining to mention the presumption against preemption). And the inferior courts—duty-bound to follow the Supreme Court—continued to apply the presumption as well. *See, e.g., Air Conditioning*, 410 F.3d at 496; *see also, e.g., Mass. Ass’n of Health Maint. Orgs. v. Ruthardt*, 194 F.3d 176, 179 (1st Cir. 1999) (same); *La. Health Serv. & Indem. Co. v. Rapides Healthcare Sys.*, 461 F.3d 529, 537 (5th Cir. 2006) (same).

## B

Our circuit was no exception. In *Air Conditioning*—a case remarkably on point here, at first glance—we followed the *Cipollone*-era cases in deciding to interpret a set of EPCA express-preemption provisions “narrowly.” 410 F.3d at 497, 501. We first restated the Supreme Court’s approach. Our interpretation of the preemption provisions was “informed by two presumptions about the nature of preemption.” *Id.* at 496 (citing *Medtronic*, 518 U.S. at 485). First was “the starting presumption that Congress did not intend to supplant state law,” at least in an area involving the “historic police powers of the States.” *Id.* (quoting *Medtronic*, 518 U.S. at 485). Second was the principle that “the purpose of Congress is the ultimate touchstone in every pre-emption case,” as revealed “not only in the text, but through [our] reasoned understanding of the way in which Congress intended the statute and its surrounding regulatory scheme to affect business, consumers, and the law.” *Id.*

(quoting *Medtronic*, 518 U.S. at 485–86). We then dutifully applied this approach—concluding that a narrow reading of the text, along with a study of the legislative history, revealed that the preemption provisions were owed a “narrow” construction. *Id.* at 497, 501. Because the *Air Conditioning* decision faithfully applied Supreme Court precedent, we confirmed its legal standard in *Sprint Telephony*, 543 F.3d at 578 (en banc).

## II

Given this backdrop, one might have thought that the question whether the presumption against preemption applies here is an easy one, already resolved by our decision in *Air Conditioning*. Because a “narrow” reading is available, one might have assumed that the presumption against preemption applies, and EPCA does not preempt the Ordinance. Such an assumption, though respectable, would be wrong—at least in the Ninth Circuit. As explained below, the law has grown more complicated and, might I say, confused since *Air Conditioning* was decided. The Supreme Court’s instructions since *Air Conditioning* have not proved entirely consistent with its earlier decisions—and inferior courts remain divided over what to make of the Court’s decision in *Franklin*, which did “not invoke” the presumption but still declined to overrule decisions where the presumption had been applied in like circumstances. *Franklin*, 579 U.S. at 125; see *Air Evac*, 910 F.3d at 762 n.1 (Wilkinson, J.). In our court, at least, we have taken a broad view of *Franklin*, and the presumption against preemption no longer seems to apply to express-preemption provisions. See *Reynolds*, 29 F.4th at 553 n.6. But I suggest the Supreme Court’s instructions on this point are not so clear, and I would welcome guidance on whether we have followed those instructions correctly.

## A

The Supreme Court used to tell us that the presumption against preemption applies to express-preemption provisions in areas of traditional state concern. But then, in *Franklin*, the Supreme Court—tasked to decide whether the Bankruptcy Act preempted a Puerto Rico debt-collection statute—stated that “because the statute contains an express pre-emption clause, we do not invoke any presumption against preemption but instead focus on the plain wording of the clause, which necessarily contains the best evidence of Congress’ pre-emptive intent.” *Franklin*, 579 U.S. at 125 (cleaned up). The Court went on to conclude that the statute was preempted—explaining that “the plain text of the Bankruptcy Code begins and ends [the] analysis” because “the statute’s language is plain.” *Id.* (cleaned up).

In doing so, the Court, I suggest, left much room for confusion. The *Franklin* Court did not acknowledge—and, most importantly, did not expressly overturn—the decades of decisions applying the presumption against preemption to express-preemption provisions. And the *Franklin* Court did not resolve—nor even discuss—the scope of the rule it was applying. Was the *Franklin* Court simply electing to “not invoke” the presumption in a case easily answered by the “plain” statutory text? Perhaps *Franklin*’s rule prohibits the application of the presumption to *all* express-preemption provisions. But perhaps *Franklin*’s rule also depends on other considerations—such as whether the statute operates in an area of traditional state concern, *see Bates*, 544 U.S. at 449, or whether the preemption provision is truly in equipoise, *see Shuker v. Smith & Nephew, PLC*, 885 F.3d 760, 771 n.9 (3d Cir. 2018); *Bates*, 544 U.S. at 432 (explaining that even if another “plausible alternative” reading were available, “this Court would have a duty to



accept the reading disfavoring pre-emption”). Perhaps the Court is moving away from applying preemption with an eye to the legislative intent and purpose that were so important during the *Cipollone* era, and toward an approach centered on the plain text enacted by Congress. *Compare, e.g., Franklin*, 579 U.S. at 125 (beginning and ending the analysis with “plain text”), *with Medtronic*, 518 U.S. at 485, 490–91 (examining the “basic purpose of the legislation as well as its history”). With respect, *Franklin* leaves much unanswered—and I wonder if its “drive-by ruling,” which appears to “contradict[] the many cases before,” *Whitman*, 574 U.S. at 1003 (Scalia, J., statement respecting denial of certiorari), really goes so far as to abrogate the decades of case law applying the presumption to express-preemption provisions in so many different statutes.

## B

Our court has adopted a broad understanding of the precedential sweep of *Franklin*’s passing statement. In several post-*Franklin* decisions, we have explained, without any apparent reservation, that when “‘the statute contains an express pre-emption clause, we do not invoke any presumption against pre-emption but instead focus on the plain wording of the clause, which necessarily contains the best evidence of Congress’ pre-emptive intent.’” *Int’l Bhd. of Teamsters, Loc. 2785 v. Fed. Motor Carrier Safety Admin.*, 986 F.3d 841, 853 (9th Cir. 2021) (quoting *Franklin*, 579 U.S. at 125) (cleaned up); *see also Nat’l R.R. Passenger Corp. v. Su*, 41 F.4th 1147, 1153 n.1 (9th Cir. 2022) (same); *Reynolds*, 29 F.4th at 553 n.6 (same); *Connell v. Lima Corp.*, 988 F.3d 1089, 1097 (9th Cir. 2021) (same); *Atay v. County of Maui*, 842 F.3d 688, 699 (9th Cir. 2016) (same). Our circuit has also declined to apply the presumption even beyond *Franklin*’s immediate context—including in areas of

traditional state concern, *see Int'l Bhd. of Teamsters*, 986 F.3d at 853, and cases involving statutory ambiguity, *see Reynolds*, 29 F.4th at 553 n.6. Perhaps that is a plausible reading of the Supreme Court's instructions, when all the Court's cases are read together. But I have my reservations, and I regret that, with due respect for my colleagues, we have not meaningfully grappled with the issue.

## 1

First, I am not convinced that we have correctly followed the Supreme Court's instructions in this admittedly troubled area. The Supreme Court is always free, of course, to change its precedent. But our court does not enjoy such power. As explained, while *Franklin* declined to invoke the presumption, it also declined expressly to mention—much less to overrule—the many cases where the Court had repeatedly applied the presumption. I do not read *Franklin*'s passing remark as *sub silentio* overruling the decades of Supreme Court cases that held—indeed, mandated—that the presumption applies. And I have real doubts about whether *Franklin* abrogated Ninth Circuit precedents that rested on pre-*Franklin* Supreme Court decisions. Perhaps *Franklin*'s rule could be read modestly and reconciled with some of those decisions. *See Shuker*, 885 F.3d at 771 n.9 (giving *Franklin* a narrow reading). And perhaps *Franklin* could be understood to leave intact circuit precedents that were based on Supreme Court decisions that *Franklin* declined directly to disturb. *See, e.g., Air Conditioning*, 410 F.3d at 495 (relying on *Medtronic*, 518 U.S. at 485); *Golden Gate Rest. Ass'n v. City & County of San Francisco*, 546 F.3d 639, 647 (9th Cir. 2008) (relying on *Travelers*, 514 U.S. at 661); *cf. Dialysis*, 938 F.3d at 259 n. 11 (concluding that *Franklin* did not abrogate circuit precedent predicated on *Travelers*). In the face of so much law from the Court requiring the

application of the presumption over the years, I would not rush to read *Franklin* as categorically establishing that the presumption is inapplicable to express-preemption provisions across the board.

2

Second, whatever the extent of *Franklin*'s reach, I am concerned that our court has not adequately grappled with this difficult question. I regret that essentially none of our decisions relying on *Franklin* to jettison our pre-*Franklin* approach offered any express discussion of the *Miller* or *Agostini* doctrines—ordinarily a requirement for us to act in the teeth of old precedent. *See, e.g., Miller*, 335 F.3d at 900 (holding that a prior circuit authority is only abrogated where it is “clearly irreconcilable” with the “reasoning or theory of intervening higher authority”); *Agostini*, 521 U.S. at 237 (holding that “lower courts should follow the case which directly controls, leaving to this Court the prerogative of overruling its own decisions”). Our cases that have addressed *Franklin*'s scope and effect have said, with all due respect, very little—and, with due respect again, nothing that directly addresses the inquiries *Miller* and *Agostini* require us to conduct. *See Nat'l R.R. Passenger Corp.*, 41 F.4th at 1153 n.1; *Reynolds*, 29 F.4th at 553 n.6; *Teamsters, Loc. 2785*, 986 F.3d at 853; *Atay*, 842 F.3d at 699; *Connell*, 988 F.3d at 1097. Perhaps our court has correctly interpreted the Supreme Court's instructions, but the lack of any meaningful engagement with the question does not inspire confidence.

3

But I do not write on a blank slate. Even though *Air Conditioning* applied the presumption to an express-preemption provision in EPCA, I understand the Ninth Circuit precedent since *Franklin* to instruct that the broad

reading of *Franklin* is now our court’s law—meaning that at least where, as here, we are tasked to interpret the preemptive scope of a new express-preemption provision, the presumption against preemption is inapplicable. *See, e.g., Reynolds*, 29 F.4th at 553 n.6; *supra* at 33 (collecting cases establishing this rule). Under this approach, even if *Air Conditioning* continues to govern the specific preemption provisions it was tasked to construe (42 U.S.C. §§ 6297(a), 6316(a)-(b)), it should not be extended to the neighboring-but-distinct express-preemption provision we are required to interpret today (42 U.S.C. § 6297(c))—and so the presumption does not apply here. Perhaps that is a puzzling and unsatisfying result. But it is the one that Ninth Circuit precedent seems to require.

### C

One final note. I am not alone in my confusion over how to interpret the Supreme Court’s instructions. As others have observed, the Supreme Court’s “somewhat varying pronouncements on presumptions in express preemption cases” have caused divisions in the circuits, in what Judge Wilkinson has described as “the great preemption wars.” *Air Evac*, 910 F.3d at 762 n.1 (collecting varying Supreme Court instructions); *see also Dialysis*, 938 F.3d at 258 (collecting circuit split).

There is much confusion over how broadly to read *Franklin*’s passing remark—and what to do with the many cases, unmentioned by *Franklin*, where the presumption had applied. Some circuits (including ours) have read *Franklin* broadly to prohibit applying the presumption to express-preemption provisions in future cases. *See Atay v. County of Maui*, 842 F.3d 688, 699 (9th Cir. 2016); *Dialysis Newco, Inc. v. Cmty. Health Sys. Grp. Health Plan*, 938 F.3d 246,

259 (5th Cir. 2019); *Watson v. Air Methods Corp.*, 870 F.3d 812, 817 (8th Cir. 2017); *EagleMed LLC v. Cox*, 868 F.3d 893, 903 (10th Cir. 2017). Other courts, however, are not so sure—and the Third Circuit, at least, has read *Franklin* to permit applying the presumption where an express-preemption provision implicates an area of traditional state concern. See *Shuker*, 885 F.3d at 771 n.9; cf. *Air Conditioning*, 410 F.3d at 496 n.1.

As inferior-court judges, we ultimately must address the important question about whether *Franklin* has spoken with sufficient clarity to abrogate existing Supreme Court and circuit precedent—or whether *Franklin* can be reconciled with at least some of those cases. See, e.g., *Miller*, 335 F.3d at 900 (abrogation of circuit precedent); *Agostini*, 521 U.S. at 237 (abrogation of Supreme Court precedent); *Khan v. State Oil Co.*, 93 F.3d 1358, 1363 (7th Cir. 1996) (Posner, J.). While some circuits have given that issue careful attention, *Dialysis*, 938 F.3d at 259 n.11 (declining to “extend” a pre-*Franklin* circuit decision that rested on *Travelers*, but also declining to “abrogate[]” it), the question of *Franklin*’s abrogating reach remains unsettled—with significant implications for the vast and important areas of law where Congress has sought to extend federal supremacy.

\* \* \*

We are duty-bound to apply binding precedents of the Supreme Court and the Ninth Circuit. Alas, those precedents “are not always clear, consistent, or coherent.” *Separation of Church & State Comm. v. City of Eugene*, 93 F.3d 617, 627 (9th Cir. 1996) (O’Scannlain, J., concurring). Here, I believe I am bound by our post-*Franklin* precedents to hold that the presumption is inapplicable to the express-preemption provision before us today. And for that reason, I join the

panel's opinion. But I remain concerned that this area of law is troubling and confused, with tensions in the Supreme Court's precedents, splits in the circuits, and important practical questions unanswered. Greater clarity and further guidance from the Court on how to navigate preemption doctrine after *Franklin* would be most welcome.

---

BAKER, Judge, concurring:

I write separately to express my reservations about the California Restaurant Association's standing and to explain my view of why the City of Berkeley's Ordinance No. 7,672-N.S. ("Ordinance") invades the core area preempted by the Energy Policy and Conservation Act ("EPCA"), 42 U.S.C. § 6297(c).

I

To have associational standing, an organization must establish that:

- (a) its members would otherwise have standing to sue in their own right;
- (b) the interests it seeks to protect are germane to the organization's purpose; and
- (c) neither the claim asserted nor the relief requested requires the participation of individual members in the lawsuit.

*Assoc. Gen. Contractors of Am., San Diego Chapter, Inc. v. Cal. Dep't of Transp.*, 713 F.3d 1187, 1194 (9th Cir. 2013) ("*AGC*"). The second and third elements of this test are not in dispute here.

As to the first element, an organization must establish that “a member suffers an injury-in-fact that is traceable to the defendant and likely to be redressed by a favorable decision.” *Id.* (citing *Braunstein v. Ariz. Dep’t of Transp.*, 683 F.3d 1177, 1184 (9th Cir. 2012)). To do so, the organization must make “specific allegations establishing that at least one *identified member* had suffered or would suffer harm.” *Id.* (emphasis by the *AGC* court and quoting *Summers v. Earth Island Inst.*, 555 U.S. 488, 498 (2009)). This “requirement of naming the affected members has never been dispensed with in light of statistical probabilities.” *Id.* (quoting *Summers*, 555 U.S. at 498–99).<sup>1</sup> Thus, when an organizational plaintiff asserting associational standing failed at summary judgment to “identify any affected members by name” or “submit[ ] declarations by any of its members attesting to harm they have suffered or will suffer” from the challenged policy, we held that the organization could not rely on “the general allegations in its complaint asserting that its members would suffer harm” and dismissed the appeal for lack of standing. *AGC*, 713 F.3d at 1194–95.<sup>2</sup>

Here, the standing allegations in the California Restaurant Association’s complaint identify no individual member injured by the challenged Berkeley Ordinance:

The CRA’s members include both restaurant owners and chefs. It has members that do

---

<sup>1</sup> The only exception to this rule is “where *all* the members of the organization are affected by the challenged activity.” *Summers*, 555 U.S. at 499 (emphasis in original).

<sup>2</sup> In *Summers*, the organizational plaintiff failed to identify any injured members at trial. *See* 555 U.S. at 500.

business in Berkeley, California, or who seek to do business in Berkeley, whose interests will be directly affected by this Ordinance. The CRA has one or more members who are interested in opening a new restaurant or in relocating a restaurant to a new building in Berkeley after January 1, 2020, but who cannot do so because of the Ordinance’s ban on natural gas. One or more members would seek to open or relocate a restaurant in a new building in Berkeley but for the ban on natural gas. . . .

Under *Summers* and our decision in *AGC*, the Association’s failure to identify any specific member injured by the Ordinance could be fatal to its standing. *See Summers*, 555 U.S. at 499 (“In part because of the difficulty of verifying the facts upon which such probabilistic standing depends, the Court has *required* plaintiffs claiming an organizational standing to identify members who have suffered the requisite harm . . . .”) (emphasis added).<sup>3</sup>

But *AGC* is not our last word on *Summers*. More recently, in *National Council of La Raza v. Cegavske*—as here, on appeal from dismissal at the pleading stage—we rejected the argument “that *Summers*, an environmental case

---

<sup>3</sup> Relying on circuit precedent, *Natural Resources Defense Council v. EPA*, 735 F.3d 873 (9th Cir. 2013), the panel correctly holds that the Association’s allegations sufficiently allege a “credible threat” of a “probabilistic harm” for standing purposes at the pleading stage. Opinion at 12. In that case, which came to us on a petition for review of agency action, the organizational petitioner identified some of its injured members by attaching their declarations to its brief. *See, e.g.*, No. 12-70268, Dkt. No. 18-3.



brought under the National Environmental Policy Act, stands for the proposition that an injured member of an organization must always be specifically identified in order to establish Article III standing for the organization.” 800 F.3d 1032, 1041 (9th Cir. 2015). Instead, we stated that an organization asserting associational standing need not identify an injured member “[w]here it is relatively clear, rather than merely speculative, that one or more members have been or will be adversely affected by a defendant’s action, and where the defendant need not know the identity of a particular member to understand and respond to an organization’s claim of injury. . . .” *Id.*

I think it is “relatively clear” that at least one of the Association’s members will be harmed by the challenged Ordinance, and the City doesn’t need to know the identity of that member to understand and respond to the Association’s complaint at the pleading stage. Thus, under *Cegavske*—which is in tension with *Summers* and our decision in *AGC*—the Association’s failure to identify in its complaint any member injured by the Ordinance does not defeat its standing.

And quite apart from what we said in *Cegavske*, it’s unclear whether the requirement that an organizational plaintiff specifically identify injured members even applies at the pleading stage. As standing is an “indispensable part of the plaintiff’s case,” *Lujan v. Defs. of Wildlife*, 504 U.S. 555, 561 (1992), it “must be supported in the same way as any other matter on which the plaintiff bears the burden of proof, *i.e.*, with the manner and degree of evidence required at the successive stages of the litigation.” *Id.*

At the pleading stage, an organizational plaintiff need only assert “general factual allegations of injury [to its

members] resulting from the defendant's conduct . . . , for on a motion to dismiss [a court] presume[s] that general allegations embrace those specific facts that are necessary to support the claim." *Id.* (cleaned up and emphasis added). Here, because we presume that they are true, under *Lujan* the complaint's general factual allegations of injury to the Association's members arguably suffice even though those allegations identify no injured member.<sup>4</sup>

But since *Lujan*, in *Ashcroft v. Iqbal*, 556 U.S. 662 (2009), and *Bell Atlantic Corp. v. Twombly*, 550 U.S. 544 (2007), the Court has "moved us away from a system of pure notice pleading." *In re Century Aluminum Co. Sec. Litig.*, 729 F.3d 1104, 1107 (9th Cir. 2013) (citing 5 Wright & Miller, *Federal Practice and Procedure* § 1216, at 71 (2012 supp.)). "In addition to providing fair notice," *id.*, a complaint "must allege 'factual content that allows the court to draw the reasonable inference that the defendant is liable for the misconduct alleged,' " *id.* (quoting *Iqbal*, 556 U.S. at 678). As to jurisdictional allegations, *Iqbal* and *Twombly* require that "the plaintiff must allege sufficient facts that, taken as true, 'demonstrat[e] each element' of Article III standing." *Jones v. L.A. Cent. Plaza LLC*, 74 F.4th 1053, 1057 (9th Cir. 2023) (brackets in original) (quoting *Spokeo*,

---

<sup>4</sup> *AGC* appears to imply as much. See 713 F.3d at 1195 (distinguishing *Northeastern Fla. Chptr. of Assoc. Gen. Contractors of Am. v. City of Jacksonville*, 508 U.S. 656, 668–69 (2013), because it involved a verified complaint's general allegations of injury to an organization's members that "had to [be] accept[ed] . . . as true" at summary judgment because they were unchallenged, whereas *AGC* involved an unverified complaint's general allegations of injury disputed at summary judgment) (emphasis added). Here, even though the Association's general allegations of injury are disputed, we must accept them as true because we are at the pleading stage.

*Inc. v. Robins*, 578 U.S. 330, 338 (2016)); see also *id.* at 1056 n.1 (observing that circuit precedent holding that *Iqbal* does not apply in the Federal Rule of Civil Procedure 12(b)(1) context is no longer viable after *Spokeo*). In the wake of *Spokeo*, the continuing vitality of *Cegavske* is an open question.

Although whether an organizational plaintiff asserting associational standing need specifically identify an injured member at the pleading stage is unsettled and at the center of a circuit split,<sup>5</sup> no such uncertainty exists at summary

---

<sup>5</sup> Compare *Draper v. Healey*, 827 F.3d 1, 3 (1st Cir. 2016) (holding that an organizational plaintiff must name at least one injured member in its complaint); *N.J. Physicians, Inc. v. President of U.S.*, 653 F.3d 234, 241 (3d Cir. 2011) (same); and *S. Walk at Broadlands Homeowner's Ass'n, Inc. v. OpenBand at Broadlands, LLC*, 713 F.3d 175, 184–85 (4th Cir. 2013) (same), with *Cegavske*, 800 F.3d at 1041, and *Bldg. & Constr. Trades Council of Buffalo, N.Y. & Vicinity v. Downtown Dev., Inc.*, 448 F.3d 138, 145 (2d Cir. 2006) (stating, pre-*Summers*, that “the defendants cite to no authority—nor are we aware of any—that supports the proposition that an association must ‘name names’ in a complaint in order properly to allege injury in fact to its members”). Cf. *Prairie Rivers Network v. Dynegy Midwest Generation, LLC*, 2 F.4th 1002, 1010, 1011 (7th Cir. 2021) (holding that an organizational plaintiff failed to show associational standing at the pleading stage when it failed “to allege facts sufficient to show that at least one of its members could sue in their own right,” but reserving the question whether circuit precedent relieving such a plaintiff of the obligation to expressly identify an injured member “survives *Summers*”).

If the Supreme Court ultimately resolves this conflict by holding that an organizational plaintiff alleging associational standing must identify at least one injured member in its complaint, such a plaintiff should ordinarily be given an opportunity to cure any failure to do so, because any such failure merely involves an incomplete “statement[ ] about jurisdiction that actually exists”—assuming there is such a member.

judgment. There, an organizational plaintiff “must set forth by affidavit or other evidence specific facts” substantiating the allegations of injury to its members. *Lujan*, 504 U.S. at 561 (cleaned up). “And at the final stage, those facts (if controverted) must be supported adequately by the evidence adduced at trial.” *Id.* (cleaned up). Thus, under *Lujan*, *Summers*, and our decision in *AGC*, at summary judgment or trial an organizational plaintiff is undoubtedly obligated to identify one or more of its injured members—among other “specific facts” detailing the nature of their asserted injury.<sup>6</sup>

---

*Newman-Green, Inc. v. Alfonso-Larrain*, 490 U.S. 826, 831 (1989); see 28 U.S.C. § 1653 (“Defective allegations of jurisdiction may be amended, upon terms, in the trial or appellate courts.”). Under this statute, a “district court . . . should . . . allow [ ] amendment if it [is] made aware of the pleading defect.” *Snell v. Cleveland, Inc.*, 316 F.3d 822, 828 n.6 (9th Cir. 2002). A complaint with a jurisdictional pleading defect “should not [be] dismissed without leave to amend . . . unless it is clear, upon de novo review, that the complaint could not be saved by amendment.” *Id.* And even on appeal from dismissal at the pleading stage, such amendment should ordinarily be allowed. See *id.* at 828 (noting that this circuit “permit[s] amendment of complaints at the appellate level in order to correct defective jurisdictional allegations”).

<sup>6</sup> If an organizational plaintiff asserting associational standing neglects to identify an injured member at summary judgment or trial, it thereby fails to carry an element of its “burden of proof.” *Lujan*, 504 U.S. at 561. In that instance, 28 U.S.C. § 1653 appears to have no application, because it “speaks of amending ‘allegations of jurisdiction,’” *Newman-Green*, 490 U.S. at 831 (emphasis in original), not curing wholesale failures of *proof*. Cf. *Summers*, 555 U.S. at 500 (holding that supplementation of the district court record with affidavits from the organization’s members to establish standing was not permitted “in the circumstances here: *after the trial is over, judgment has been entered, and a notice of appeal has been filed*”) (emphasis in original).

## II

Justice Scalia famously noted—in the context of the Employee Retirement Income Security Act of 1974 (ERISA)’s express preemption clause,<sup>7</sup> which employs broad “related to” language materially similar to EPCA’s,<sup>8</sup> see *Lamar, Archer & Cofrin, LLP v. Appling*, 138 S. Ct. 1752, 1759 (2018) (equating “ ‘[c]oncerning’ with ‘relating to’ ”); *Morales v. Trans World Airlines, Inc.*, 504 U.S. 374, 383 (1992) (defining “related to” as, among others, “to have bearing or concern”) (quoting *Black’s Law Dictionary* 1158 (5th ed. 1979))—that “applying the ‘relate to’ provision according to its terms was a project doomed to failure, since, as many a curbstone philosopher has observed, everything is related to everything else.” *Cal. Div. of Labor Standards Enf’t v. Dillingham Constr., N.A., Inc.*, 519 U.S. 316, 335 (1997) (Scalia, J., concurring). Thus, the breadth of EPCA’s preemption provision, like ERISA’s, “does not mean the sky is the limit.” *Dan’s City Used Cars, Inc. v. Pelkey*, 569 U.S. 251, 260 (2013). For that reason, EPCA preemption is unlikely to reach a host of state and local regulations that incidentally impact “the quantity of [natural gas] directly consumed by a [covered] product at point of use.” 42 U.S.C. § 6291(4).

---

<sup>7</sup> ERISA “supersede[s] any and all State laws insofar as they may now or hereafter relate to any employee benefit plan described in section 1003(a) of this title.” 29 U.S.C. § 1144(a).

<sup>8</sup> EPCA’s preemption clause provides that after a federal energy conservation standard applies to a covered product, “no State regulation concerning the energy efficiency, energy use, or water use of such covered product shall be effective with respect to such product.” 42 U.S.C. § 6297(c).

For example, nothing in EPCA’s text or structure suggests any concern with state and local taxes that might reduce consumption of natural gas. Thus, at least as far as EPCA is concerned, states and local governments are likely free to impose carbon taxes designed to discourage such consumption. Nor is there any indication from its text or structure that EPCA speaks to the distribution of natural gas. If a state or local government terminates existing gas utility service or declines to extend such service, EPCA likely has no application.<sup>9</sup>

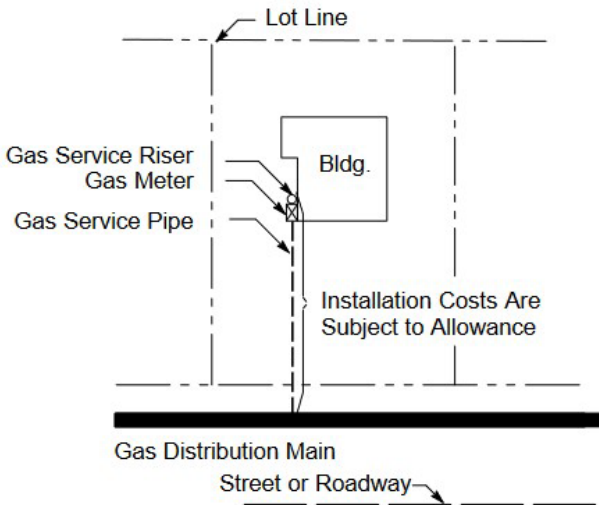
But the challenged Ordinance does not implicate a utility’s distribution of natural gas. Instead, like EPCA, it assumes that gas service is otherwise available at premises with products covered by the federal statute. *See* BMC § 12.80.030(E) (defining prohibited “natural gas infrastructure” as “fuel gas piping, other than service pipe, in or in connection with a building, structure or within the property lines of premises, extending *from the point of delivery at the gas meter* as specified in the California Mechanical Code and Plumbing Code”) (emphasis added).

The Pacific Gas & Electric Company (PG&E)—the utility serving Berkeley—explains in a document cited by

---

<sup>9</sup> For the same reason, EPCA’s preemption provision—which also encompasses state and local regulations “concerning the . . . [electricity] use” and “water use” of “covered product[s],” 42 U.S.C. § 6297(c)—almost certainly does not affect state or local measures curtailing the distribution of water due to droughts or electricity due to wildfire risk or grid limitations. *See* Brief of *Amici Curiae* Energy and Environmental Law Professors in Support of Defendant-Appellee City of Berkeley (*Amici* Law Professors), at 14, 17 (describing state and local authority to limit electricity and water distribution for various public purposes). As I read it, EPCA assumes that energy service or water is otherwise available to the premises at which a covered product is used.

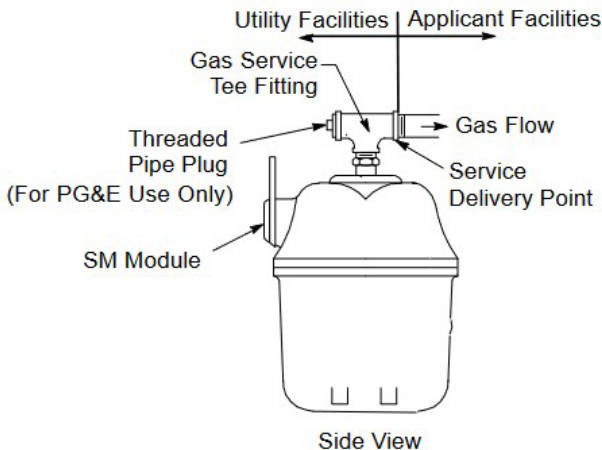
the *Amici* Law Professors that “the service delivery point for the gas supply is the point where PG&E’s facilities connect to the applicant’s house pipe (i.e., houseline).” Pacific Gas & Elec. Co., *Electric & Gas Service Requirements (TD-7001M) 2022–2023*, at 2-50 (2022) (“*PG&E Manual*”).<sup>10</sup> The following diagram “illustrates a typical service delivery point,” *id.*:



**Figure 2-1  
Typical Gas Service Installation**

<sup>10</sup> [https://www.pge.com/pge\\_global/common/pdfs/services/building-and-renovation/greenbook-manual-online/greenbook\\_manual\\_full.pdf](https://www.pge.com/pge_global/common/pdfs/services/building-and-renovation/greenbook-manual-online/greenbook_manual_full.pdf).

*Id.* at 2-6. And to zero in even further, as shown in the side view of a typical meter below, the service delivery point is just after the meter:



*Id.* at 2-51; *see also id.* at 2-49 (“The [customer’s] houseline at the service delivery point typically is located after the PG&E service tee for residential services.”).

PG&E further explains that it “is responsible for maintaining the system that delivers natural gas, up to and including the gas meter.” Pacific Gas & Elec. Co., *Natural Gas Customers: Important gas safety information regarding your pipelines* at 1 (2021).<sup>11</sup> PG&E’s customers, on the other hand, are

responsible for maintaining the [customer]-installed and owned gas service piping, valves, automatic shut-off devices (e.g.,

<sup>11</sup> [https://www.pge.com/pge\\_global/common/pdfs/your-account/your-bill/understand-your-bill/bill-inserts/2021/0821-New-Gas-Customer.pdf](https://www.pge.com/pge_global/common/pdfs/your-account/your-bill/understand-your-bill/bill-inserts/2021/0821-New-Gas-Customer.pdf).



earthquake valves), or other piping components on any premises or in any building. These [customer]-owned components must be installed downstream of (i.e., after) the gas supply service delivery point.

*PG&E Manual* at 2-49. In short, the customer-owned piping constitutes everything downstream of the service tee fitting on the utility’s gas meter.

The Berkeley Ordinance—a *building code*—prohibits the customer-owned piping downstream of the meter, and scrupulously avoids touching on infrastructure owned by the utility, including the meter or the service pipe connecting the meter to the gas distribution main. And although EPCA has little, if anything, to say about a state or local government’s regulation of a utility’s distribution of natural gas to customers, it has everything to say about “State or local building code[s] for new construction concerning the . . . energy use of . . . covered product[s] . . . .” 42 U.S.C. § 6297(f)(3). “[R]egulation[s] or other requirement[s]” in such codes *are* preempted unless they “compl[y] with all of” various specified conditions. *See id.* § 6297(f)(3)(A)–(G). And it’s undisputed the Ordinance does not do so.

Thus, far from having only “a tenuous, remote, or peripheral connection,” *N.Y. State Conf. of Blue Cross & Blue Shield Plans v. Travelers Ins. Co.*, 514 U.S. 645, 661 (1995), to the subject matter preempted by EPCA, the Berkeley Ordinance cuts to the heart of what Congress sought to prevent—state and local manipulation of building codes for new construction to regulate the natural gas consumption of covered products when gas service is otherwise available to premises where such products are

used. And as the panel explains, because EPCA would unquestionably preempt a building code that prohibited the attachment of covered appliances to the owner's piping that receives gas at the utility's service delivery point, it necessarily also preempts a building code that instead bans that piping to evade preemption. I therefore join the panel opinion in full.

---

FRIEDLAND, Circuit Judge, joined by MURGUIA, Chief Judge, and WARDLAW, GOULD, KOH, SUNG, SANCHEZ, and MENDOZA, Circuit Judges, except as to the first sentence and accompanying footnote, dissenting from the denial of rehearing en banc:

In nearly a decade on the bench, I have never previously written or joined a dissent from a denial of rehearing en banc.<sup>1</sup> I feel compelled to do so now to urge any future court that interprets the Energy Policy and Conservation Act not to repeat the panel opinion's mistakes. The opinion misinterprets the statute's key terms to have colloquial meanings instead of the technical meanings required by established canons of statutory interpretation. It thereby erroneously holds that Berkeley's ordinance is preempted.

---

<sup>1</sup> I have generally agreed with Judge Berzon's article on this issue that dissents from the denial of rehearing en banc do not improve the court's decision-making process. Marsha S. Berzon, *Dissent, "Dissentals," and Decision Making*, 100 Cal. L. Rev. 1479, 1491–92 (2012). But, as Judge Berzon explained, sometimes "dissents from the denial of rehearing en banc [can] make a useful point not made by the panel majority opinion, or any separate opinion," and such dissents "may aid other circuits considering the same or similar issues." *Id.* at 1492 n.57.

Those errors of statutory interpretation have important consequences. The panel opinion needlessly blocks Berkeley's effort to combat climate change, along with the equivalent laws passed by other local governments. Our system of federalism requires much more respect for state and local autonomy. "Deference to state lawmaking . . . permits innovation and experimentation [and] enables greater citizen involvement in democratic processes." *Ariz. State Legislature v. Ariz. Indep. Redistricting Comm'n*, 576 U.S. 787, 817 (2015) (quotation marks omitted) (quoting *Bond v. United States*, 564 U.S. 211, 221 (2011)). That deference is especially needed here. Climate change is one of the most pressing problems facing society today, and we should not stifle local government attempts at solutions based on a clear misinterpretation of an inapplicable statute.

## I.

The history of the relevant provisions of the Energy Policy and Conservation Act ("EPCA")<sup>2</sup> shows that, from the beginning, they were technical provisions with a narrow scope of preemption. When Congress first enacted EPCA in 1975, it required manufacturers to label their appliances with measures of energy efficiency and energy use. *Air Conditioning & Refrigeration Inst. v. Energy Res. Conservation & Dev. Comm'n*, 410 F.3d 492, 499 (9th Cir. 2005); H.R. Rep. No. 94-340, at 17 (1975), *as reprinted in* 1975 U.S.C.C.A.N. 1762, 1779. The Act also preempted state regulations that required the disclosure of other information related to energy consumption. *Air Conditioning*, 410 F.3d at 499 (citing Energy Policy and

---

<sup>2</sup> I use "EPCA" to refer to the Energy Policy and Conservation Act of 1975 and its subsequent amendments.

Conservation Act, Pub. L. No. 94-163, § 327, 89 Stat. 871, 926–27 (1975)).

A few years later, Congress took EPCA a step further, establishing a “nationwide conservation program for [consumer] appliances.” *Id.* The program required the Department of Energy (“DOE”) to “prescribe minimum energy efficiency standards” for “covered products” such as refrigerators and dishwashers. *Id.*; *Nat. Res. Def. Council, Inc. v. Herrington*, 768 F.2d 1355, 1362 n.1 (D.C. Cir. 1985). DOE largely failed to comply with this instruction, however, and it granted waivers that allowed states to establish their own standards. *Air Conditioning*, 410 F.3d at 499. This practice resulted in a “growing patchwork of differing State regulations” that complicated the “design, production, and marketing” of appliances. *Id.* at 500 (quoting S. Rep. No. 100-6, at 4 (1987), *reprinted in* 1987 U.S.C.C.A.N. 52, 54–55).

Frustrated by the lack of uniformity, manufacturer trade associations negotiated with the Natural Resources Defense Council to establish uniform national standards that would ease the burden on manufacturers while promoting energy conservation. *Id.* at 499–500; S. Rep. No. 100-6, at 4. In 1987, Congress amended EPCA to include those negotiated appliance standards. *Air Conditioning*, 410 F.3d at 499–500; National Appliance Energy Conservation Act of 1987, Pub. L. No. 100-12 § 5, 101 Stat. 103, 107–08 (1987) (codified as amended at 42 U.S.C. § 6295(a)–(b)). Congress simultaneously added the preemption provision at issue in this case to “counteract the systems of separate state appliance standards.” *Air Conditioning*, 410 F.3d at 500; Pub L. No. 100-12 § 327(c), 101 Stat. at 118. The provision establishes that, once a DOE standard for a covered product takes effect, “no State regulation concerning the energy

efficiency, energy use, or water use of such covered product shall be effective with respect to such product.”<sup>3</sup> 42 U.S.C. § 6297(c).

## II.

As one would expect from that history, the text of EPCA’s preemption provision guarantees uniform appliance efficiency standards. It does not create a consumer right to use any covered appliance. The panel opinion concludes that it does so by ignoring the way EPCA’s key terms are used in the context of the statute and by giving technical terms improper colloquial meanings.

It is a firmly established canon of textual interpretation that a statute must be read as a whole, and its words must be considered in context with a view towards the “logical relation” of the statute’s parts. Antonin Scalia & Bryan A. Garner, *Reading Law: The Interpretation of Legal Texts* 167 (2012); *see also, e.g., Davis v. Mich. Dep’t of Treasury*, 489 U.S. 803, 809 (1989); *King v. Burwell*, 576 U.S. 473, 486 (2015); *Sw. Airlines Co. v. Saxon*, 596 U.S. 450, 455 (2022).

Moreover, EPCA is a technical statute, so another firmly established interpretive canon requires considering the specialized meanings of key terms, rather than looking solely to colloquial usage. When interpreting a legal text, “[w]ords are to be understood in their ordinary, everyday meanings—*unless the context indicates that they bear a technical sense,*” and “[w]here the text is addressing a scientific or technical subject, a specialized meaning is to be expected.” Scalia & Garner, *Reading Law* 69, 73 (emphasis added); *see also, e.g., Van Buren v. United States*, 141 S. Ct.

---

<sup>3</sup> There are some exceptions to this provision that are not relevant here. *See* § 6297(c).

1648, 1658 n.7 (2021) (citing Scalia & Garner, *Reading Law*, at 73); *Flo & Eddie, Inc. v. Sirius XM Radio, Inc.*, 9 F.4th 1167, 1173 (9th Cir. 2021) (same); *Marquez-Reyes v. Garland*, 36 F.4th 1195, 1202 (9th Cir. 2022) (same).

### A.

The scope of EPCA’s preemption provision depends on the meaning of the term “energy use,” because the provision preempts state laws that concern the “energy use . . . of [a] covered product.” § 6297(c).<sup>4</sup> EPCA defines “energy use” as “the quantity of energy directly consumed by a consumer product at point of use, determined in accordance with test procedures under section 6293 of this title.” § 6291(4). Such test procedures measure energy use “during a representative average use cycle or period of use.” § 6293(b)(3). Accordingly, looking at the relevant provisions together, the “energy use” of an appliance is the typical amount of energy consumed per use cycle or in a given amount of time while the appliance is in operation. It is a fixed number that measures the efficiency of an appliance as manufactured.

I refer to “energy use” as a measure of efficiency, but I acknowledge that “energy efficiency” has a separate definition under EPCA. EPCA defines “energy efficiency” as the “ratio of the useful output of services from a consumer product to the energy use of such product, determined in accordance with test procedures under section 6293 of this title.” § 6291(5). “Energy efficiency” and “energy use” are both technical terms that refer to different aspects of an appliance’s efficiency: “Energy use” standards prevent

---

<sup>4</sup> Unless otherwise indicated, all section (§) citations refer to Title 42 of the U.S. Code.

appliances from using too much energy overall, while “energy efficiency” standards prevent appliances from using too much energy relative to their useful output.<sup>5</sup> Depending on the product, one or the other measure may be more appropriate, so EPCA uses “energy efficiency” standards for some products while using “energy use” standards for others. For instance, for refrigerators, which are used more or less constantly to maintain a consistent temperature, efficiency is measured through energy consumed over time—*i.e.*, “energy use.” *See* § 6295(b)(1). For room air conditioners, which create a change in temperature only some of the time, efficiency is measured through the cooling capacity (“the useful output of services”) divided by the amount of energy consumed—*i.e.*, “energy efficiency.” *See* § 6295(c)(1); Test Procedures for Room Air Conditioners, 42 Fed. Reg. 27,896, 27,899 (June 1, 1977).

In other words, both “energy use” and “energy efficiency” are performance standards. Indeed, EPCA defines the term “energy conservation standard” to mean a “performance standard which prescribes a minimum level of energy efficiency or a maximum quantity of energy use . . . for a covered product, determined in accordance with test procedures prescribed under section 6293 of this title.”

---

<sup>5</sup> To show how these measures would work in a concrete example, assuming the “period of use” is one hour, they could be calculated for a given appliance in the following way:

Energy Use = amount of energy consumed per hour

Energy Efficiency = “useful output of services” in that hour ÷ that Energy Use.

§ 6291(6)(A).<sup>6</sup> As a performance standard, “energy use” is a fixed measure that results from the manufacturing and design of the product. Although this measure aims to approximate the *typical* energy use of an appliance during operation, the measure does not depend on any given consumer’s *actual* use. That means a gas stove of a particular model that sits uninstalled and unused has the same “energy use” under EPCA as one that is installed and running. Applying that understanding to the facts here, Berkeley’s ordinance affects the *use* of natural gas products in a colloquial sense, but it does not affect the “energy use . . . of [a] covered product” within the meaning of the preemption provision.

Looking at the statute as a whole, this interpretation is the only one that makes sense. For instance, EPCA establishes labeling requirements to inform consumers about an appliance’s energy use, helping consumers make informed purchases. *See, e.g.*, § 6294(a)(2)(I), (a)(3). There would be no way to label an appliance with information about its “energy use” if “energy use” turned on a particular consumer’s use of the appliance after purchase. The manufacturer creating the label obviously cannot predict whether a consumer will leave the appliance sitting uninstalled in her garage. The fact that some consumer might do so does not mean that the appliance’s label should list “zero” as its energy use.

EPCA also permits DOE to require that manufacturers “submit information or reports . . . with respect to” the

---

<sup>6</sup> The definition of “energy conservation standard” also includes “water use” standards. § 6291(6)(A). The term “energy conservation standard” is secondarily defined as “a design requirement for the products specified in . . . section 6292(a) of this title.” § 6291(6)(B).



“energy use” of covered products to demonstrate their compliance with EPCA’s standards and to facilitate DOE’s administration of the statute. § 6296(d)(1). This provision does not require manufacturers to somehow monitor consumers’ use of appliances after installation. The provision is coherent only if “energy use” is a function of an appliance’s manufacturing and design specifications, such that a manufacturer can ascertain the appliance’s “energy use” prior to sale.

### B.

The fact that EPCA defines “energy use” as the quantity of energy consumed at the “point of use” does not change this analysis. § 6291(4). “Point of use” has a well-established technical meaning that must be applied here: To measure energy at the “point of use,” one measures only “site energy,” the energy that is directly consumed by the appliance from the pipe or outlet.<sup>7</sup> By contrast, “source energy” includes all the energy measured at the point of use (the “site energy”) plus the energy required to produce and deliver the energy to that site.<sup>8</sup> For instance, energy as measured at the “point of use” would include only the natural gas needed to operate a gas stove, whereas “source energy” would also include the energy consumed in extracting that

---

<sup>7</sup> David Santana Ortiz & Mark Allen Bernstein, RAND, *Measures of residential energy consumption and their relationships to DOE policy* xiii–xiv, 6–7 (1999).

<sup>8</sup> *Id.*; see also 144 Cong. Rec. S12706–07 (Oct. 20, 1998) (letter from senators explaining that DOE currently uses a “point of use” standard and that when EPCA was enacted in 1975, Congress and the President “wisely rejected” an approach to measuring energy use that would account for “exogenous factors like ‘total fuel cycle’ costs, emissions and externalities”).

natural gas, removing its impurities, and transporting it to the location of the stove.<sup>9</sup>

Congress included the term “point of use” in the definition of “energy use” not to protect “the end-user’s ability to *use* installed covered products at their intended final destinations,” as the panel opinion asserts, but instead to give a technical instruction to DOE and manufacturers. Congress was relying on the technical meaning of the term to convey that the “energy use” of an appliance under EPCA does not include indirect energy consumption upstream in the supply chain. That instruction was needed because other regulators at the time *did* consider such indirect energy consumption (“source energy”) when adopting energy standards. *See* Energy Resources Conservation and Development Commission, Staff Report, *Energy Conservation Standards for Nonresidential Buildings 5* (May 27, 1977) (report from California’s Energy Resources Conservation and Development Commission explaining that when setting certain standards, the Commission was required by a state statute to “tak[e] into account power plant and distribution losses,” not just “energy delivered to the building boundary”).

Industry and regulatory sources consistently use the term “point of use” in this technical sense, and many expressly recognize that EPCA does so as well. The following list illustrates a few examples:

- A National Academy of Sciences study, commissioned by Congress, explained that “site (point-of-use)” measures account for only the energy consumed at

---

<sup>9</sup> *See* Ortiz & Bernstein, *supra* note 7, at 6.

the site “based on specified test procedures,” while “source (full-fuel-cycle) measures” include site energy plus the energy consumed in the “extraction, processing, and transport” of fuels to the site. The study further explained as to EPCA that “[c]urrent DOE standards for the energy consumed by operating individual appliances call for measurement at the site (point of use) of the appliance.”<sup>10</sup>

- In a notice of proposed policy, DOE explained that, consistent with the National Academy of Sciences study, it “uses point-of-use measures of energy consumption” in administering EPCA. It contrasted “point-of-use” measures with another measure that accounted for “energy consumed on-site, plus energy losses that occur in the generation, transmission, and distribution of electricity.”<sup>11</sup>

---

<sup>10</sup> National Research Council, *Review of Site (Point-of-Use) and Full-Fuel-Cycle Measurement Approaches to DOE/EERE Building Appliance Energy-Efficiency Standards: Letter Report 1*, 3–4, 6 (2009); Energy Policy Act of 2005, Pub. L. No. 109-58, § 1802, 119 Stat. 594, 1123 (2005) (commissioning the study).

<sup>11</sup> Energy Conservation Program for Consumer Products and Certain Commercial and Industrial Equipment: Public Meeting and Availability of Statement of Policy for Adopting Full-Fuel-Cycle Analyses Into Energy Conservation Standards Program, 75 Fed. Reg. 51,423, 51,424 (Aug. 20, 2010).

- A study prepared for the American Gas Foundation stated that the definition of “energy use” under EPCA refers to site energy, rather than source energy (which the study referred to as “real energy”). The study continued, “[F]ederal energy efficiency policies are based upon improving energy efficiency as measured at the point of usage rather than considering the full fuel cycle of energy and natural resources.”<sup>12</sup>
- In an advance notice of proposed rulemaking, DOE explained that “EPCA and [the National Appliance Energy Conservation Act] do not permit the regulation of source energy” because those statutes “specify that efficiency must be based on the energy consumption at the point of use.”<sup>13</sup>
- In a notice of proposed rulemaking, the Federal Energy Administration (“FEA”) stated that, in considering the impact of potential energy conservation measures

---

<sup>12</sup> American Gas Foundation, *Public Policy and Real Energy Efficiency* i, v, 7, 14 (2005); *see also id.* at 50 (stating that the National Appliance Energy Conservation Act, which amended EPCA to establish efficiency standards for appliances, “use[s] site energy as the basis for qualifying appliances”).

<sup>13</sup> Energy Conservation Program for Consumer Products: Energy Conservation Standards for Residential Furnaces and Boilers, 69 Fed. Reg. 45,420, 45,426 (July 29, 2004) (citing § 6291(4) (the definition of energy use)).

on petroleum and natural gas consumption at specific buildings and industrial sites, it would look only to energy consumption “at the point of use on site,” rejecting an approach that would also look to the fuel needed to generate electricity at the power plant level.<sup>14</sup>

- In a notice of a final rule, the FEA contrasted a technical measure that represented the energy content of a unit of electricity at “the point of use” with another technical measure that took into account the energy lost in the process of generating that electricity and transmitting it to the point of use.<sup>15</sup>

Textualist principles require us to consider such sources when interpreting a technical term, rather than interpreting the term solely based on colloquial meaning. *See* Scalia & Garner, *Reading Law* 69, 73; *Corning Glass Works v. Brennan*, 417 U.S. 188, 201 (1974) (“[W]here Congress has used technical words or terms of art, ‘it [is] proper to explain them by reference to the art or science to which they [are] appropriate.’” (quoting *Greenleaf v. Goodrich*, 101 U.S. 278, 284 (1880))); *Van Buren*, 141 S. Ct. at 1658 n.7 (explaining that the Court’s narrow interpretation of the term “access” in the Computer Fraud and Abuse Act of 1986 “tracks the specialized meaning of ‘access’ in the computer context”).

---

<sup>14</sup> Energy Audits, 42 Fed. Reg. 20,012, 20,013 (Apr. 15, 1977).

<sup>15</sup> Federal Energy Administration, 42 Fed. Reg. 33,158, 33,159 (June 29, 1977).

These technical sources demonstrate that “point of use” does not refer to the place where an appliance is used; it refers to a technical way of measuring energy consumption. Given this technical meaning, the fact that Berkeley’s ordinance prevents some consumers from using a natural gas appliance at what we might colloquially refer to as the “point of use” does not affect the “energy use” of those appliances within the meaning of EPCA.

### C.

The preemption provision’s inclusion of the modifier “concerning” does not bring the ordinance within the provision’s scope. *See* § 6297(c) (“[N]o State regulation *concerning* the energy efficiency [or] energy use . . . of [a] covered product shall be effective.” (emphasis added)). To be sure, the word “concerning” expands the scope of the preemption provision beyond regulations that directly set energy efficiency or energy use standards. The statute as a whole makes clear that indirect regulations may be preempted if they aim to require consumers to use products with higher efficiency standards than those prescribed by DOE and may ultimately cause manufacturers to change the design of their products to meet those higher standards. For instance, EPCA contemplates preempting building codes that set building-wide energy efficiency standards that can only be met through the use of hyper-efficient appliances. *See* § 6297(f). Because the terms “energy use” and “energy efficiency” are product-specific, a preemption provision without the word “concerning” might not preempt building codes that set standards by, for example, capping overall energy consumption per apartment or per building.

The Supreme Court has said that “concerning” means the same thing as “relating to,” *Lamar, Archer & Cofrin, LLP v.*

*Appling*, 138 S. Ct. 1752, 1759 (2018), and it has recently counseled against reading such words too broadly, *Dubin v. United States*, 599 U.S. 110, 119 (2023). The Court explained that “[i]f ‘relate to’ were taken to extend to the furthest stretch of its indeterminacy, then for all practical purposes there would be no limits, as really, universally, relations stop nowhere.” *Id.* (cleaned up) (quoting *N.Y. State Conf. of Blue Cross & Blue Shield Plans v. Travelers Ins. Co.*, 514 U.S. 645, 655 (1995)). The Court has similarly cautioned against “‘uncritical literalism’ that would make pre-emption turn on ‘infinite connections.’” *Egelhoff v. Egelhoff*, 532 U.S. 141, 147 (2001) (quoting *N.Y. State Conf. of Blue Cross & Blue Shield Plans*, 514 U.S. at 656).

Here, “concerning” cannot transform the meaning of “energy use.” Berkeley’s ordinance obviously concerns natural gas, and natural gas is a type of energy. But to say that the ordinance therefore concerns “energy use,” as defined by EPCA, is to engage in “uncritical literalism.” Berkeley did not adopt its ordinance to require consumers to use appliances with higher efficiency standards than those prescribed by DOE. The ordinance was intended to slow climate change and reduce public safety hazards and health risks associated with the combustion of natural gas. Berkeley Mun. Code § 12.80.010(B) (finding that the ordinance was necessary to address sea level rise and increased wildfires caused by climate change), (C) (finding that the ordinance was necessary to address “asthma and other health conditions associated with poor indoor and outdoor air quality [that are] exacerbated by the combustion of natural gas”). Transitioning from fossil fuels to non-greenhouse-gas-producing energy sources may not decrease total energy consumption. Indeed, some gas appliances are more efficient than electric appliances, so the ordinance may

have the indirect effect of *increasing* energy consumption in new buildings in some circumstances. *See, e.g.*, 10 C.F.R. § 430.32(e)(1)(ii) (setting a more stringent standard for gas furnaces than for electric furnaces). The ordinance also gives manufacturers no reason to change the design of their natural gas products to meet standards higher than those prescribed by DOE. It simply directs consumers to one set of products with one set of federal efficiency standards (electric appliances) over another set of products with different federal efficiency standards (gas appliances). *See, e.g.*, § 6295(e)(1)(A), (C) (setting one standard for gas water heaters and another for electric water heaters).

### III.

EPCA's history, text, and structure all show that the Berkeley ordinance is not preempted because it does not affect "energy use" within the meaning of the statute. The panel opinion makes much of the notion that a state cannot do indirectly what it could not do directly. But that notion is beside the point because EPCA would not preempt a direct prohibition on natural gas appliances enacted for the reasons Berkeley had here. Even such a direct prohibition would not affect the "energy use" of any appliance.

Berkeley adopted its ordinance to address an urgent problem of the highest importance. The panel opinion unnecessarily strikes down the ordinance by entirely misinterpreting a narrow preemption provision about appliance standards. I hope other courts will not repeat the panel opinion's mistakes.

I respectfully dissent from the denial of rehearing en banc.



BERZON, Circuit Judge, with whom PAEZ and FLETCHER, Circuit Judges, join, respecting the denial of rehearing en banc:

I agree with Judge Friedland's dissent from the denial of rehearing en banc, including her explanation as to why this is the type of case in which dissent from denial of rehearing en banc is appropriate. *See* Dissent from Denial of Rehearing En Banc at 50 n.1.

# ELECTRIC & GAS SERVICE REQUIREMENTS

(TD-7001M)

**2022–2023**

cited in Cal. Rest. Ass'n v. City of Berkeley  
No. 21-16278am archived December 27, 2023

Visit us at

[www.pge.com/greenbook](http://www.pge.com/greenbook)



*Pacific Gas and  
Electric Company*<sup>TM</sup>

**WE DELIVER ENERGY.<sup>SM</sup>**

cited in Cal. Rest. Ass'n v. City of Berkeley  
No. 21-16278am archived December 27, 2023

# Electric & Gas Service Requirements (TD-7001M)

cited in Cal. Rest. Ass'n v. City of Berkeley  
No. 21-16278am archived December 27, 2023

# 2022–2023

Visit us at

[www.pge.com/greenbook](http://www.pge.com/greenbook)



*Pacific Gas and  
Electric Company*<sup>TM</sup>

**WE DELIVER ENERGY.<sup>SM</sup>**

Copyright © 2022  
by Pacific Gas and Electric Company.  
All rights reserved.

No part of this publication may be reproduced, stored in a retrieval system,  
or transmitted in any form or by any means, electronic, mechanical,  
photocopying, recording, or otherwise, without the prior written permission  
of the publisher. For information, address:

*cited in Cal. Post. Ass'n v. City of Berkeley  
No. 21-16278am Archived December 27, 2023*

Pacific Gas and Electric Company  
Technical Document Management  
Mail Code N9H  
P.O. Box 770000  
San Francisco, CA 94177

Produced by  
Technical Document Management



***Pacific Gas and  
Electric Company***<sup>TM</sup>

---

**Pacific Gas and Electric Company (PG&E)  
Electric and Gas Service Requirements  
(TD-7100M)**

---

Architects and Engineers

Electrical Contractors

Plumbing Contractors

City and County Building Inspectors

Manufacturers of Electrical Equipment

Pacific Gas and Electric Company Employees

**2022–2023 Edition**

**(Supersedes All Previous Editions and Revisions)**

The *Electric and Gas Service Requirements* (i.e., *Greenbook*) is a guide to Pacific Gas and Electric Company (PG&E) requirements and policies for establishing electric and gas service to new or remodeled applicant installations. The illustrations and explanations in this manual describe how to construct and install services and equipment. Alternate designs and installations that do not meet the requirements in this manual will not be approved.

In addition to the utility requirements, local or state officials may stipulate additional provisions for the installation of equipment and materials that are in their authorized areas of responsibility and jurisdiction.

Should you have any questions regarding this manual, please call your local PG&E representative (see [Table FM-1, “Service Planning Office and Inspection Desk Contact Information,”](#) starting on Page iv.).

**Applicant gas and electric service and meter installation arrangements are subject to PG&E’s review and approval.**

Applicants should contact their local PG&E representatives as soon in the planning process as possible.

**NOTE:** The acronym PG&E is used throughout this manual to designate Pacific Gas and Electric Company.



The PG&E *Electric and Gas Service Requirements* (i.e., *Greenbook*) is updated and published regularly. The 2022–2023 *Greenbook* supersedes all previous editions and revisions and the requirements, here in, are effective until a new revision is released the following year.

**Notice: This Manual Is Subject to Change**

### **Information and requirements in this manual are subject to change over time.**

PG&E may revise its design and construction documents relating to applicant service requirements between updates to this manual. Except when required by law, PG&E applies only those construction and design specifications, standards, terms, and conditions that apply to a new extension of service project for the 18 months following the date the application for a new extension of service project is approved. The Approval Date of a new extension of service application refers to the earlier of either the effective date of the contract for the extension of gas and/or electric service or the date that PG&E first invoices the customer for the extension of gas and/or electric service. These requirements apply as long as applicants complete the approved projects within 18 months. If the applicant has not started construction within 18 months of PG&E's initial approval, PG&E may review the design and, if warranted, refresh the cost estimate. If the applicant does not fulfill obligations under the extension agreement, PG&E may, at its discretion, cancel the agreement (see Provisions Form 62-0982, Section 20). PG&E can then request another review of the design before approving construction activities.

The online versions of the *Electric & Gas Service Requirements*, located at [www.pge.com/greenbook](http://www.pge.com/greenbook), are updated as quickly as possible when changes occur. The bound manual is not reprinted until the next scheduled print date regardless of changes in processes or requirements. **Therefore, it is imperative that applicants for all gas and electric service projects consult the online version of this manual ([www.pge.com/greenbook](http://www.pge.com/greenbook)) before finalizing project plans.**



For more information, please contact your local PG&E project coordinator.

- Region 1 – North Coast
- Region 2 – North Valley and Sierra
- Region 3 – Bay Area
- Region 4 – South Bay and Central Coast
- Region 5 – Central Valley

See [Table FM-1, “Service Planning Office and Inspection Desk Contact Information.”](#) starting on Page iv.



Table FM-1 Service Planning Office and Inspection Desk Contact Information

Service Planning Office and Inspection Desk Contact Information							
Region	Division	Cities Covered	Work Center	Address	Zip Code	Phone	Email
Region 1: North Coast	Humboldt	Ukiah, All Mendocino and Lake Counties Inland	Ukiah	2641 N. State St	95482	(707) 468-3914	<a href="mailto:EDLHCCDUkiah@pge.com">EDLHCCDUkiah@pge.com</a>
Region 1: North Coast	Humboldt	Eureka, Arcata, Mckinleyville, Fortuna, Garberville, Alderpoint, Ferndale, Trinidad, Benbow, Blue Lake, Rio Dell, Redway, Shelter Cove, Willow Creek, Orick, Loleta, Cutten, Humboldt Hill, Scotia, Myers Flat, Weott, Samoa, Hydesville, Phillipsville, Fields Landing, Myrtle town, Big Lagoon, Miranda, Redcrest, Manila, Pine Hills, Bayview	Eureka	2555 Myrtle Ave	95501	(707) 445-5533	<a href="mailto:LHCCDEureka@pge.com">LHCCDEureka@pge.com</a>
Region 1: North Coast	North Bay	Mill Valley, Kentfield, Greenbrae, Madera, Larkspur, Ross, Sausalito, Tiburon, Marin City, Belvedere, Novato, San Rafael, San Anselmo, Fairfax, Nicasio, Woodacre, Forest Knolls, Lagunitas, Point Reyes, Inverness, Dog Town, Bolinas, Stinson Beach, Olema, Muir Beach, Parts of Marshall	San Rafael	1220 Andersen Dr	94901	(415) 257-3130  (415) 257-3431	<a href="mailto:EDLHCCDSanRafael@pge.com">EDLHCCDSanRafael@pge.com</a>
Region 1: North Coast	North Bay	Napa, Ruthford, Yountville, Saint Helena, Deer Park, Calistoga, Angwin, Pope Valley, Berryessa, Vallejo, Benicia, American Canyon	Napa	1850 Soscol Ave, Suite 105	94559	(707) 257-5918	<a href="mailto:EDLHServiceDeskNapa-@pge.com">EDLHServiceDeskNapa-@pge.com</a>
Region 1: North Coast	Sonoma	Sonoma, Petaluma, Cotati, Rohnert Park, Sebastopol, Santa Rosa, Windsor, Healdsburg, Cloverdale, Bodega, Bodega Bay, Annapolis, Cazadero, Duncan Mills, El Verano, Eldridge, Forestville, Geyserville, Jenner, Kenwood, Penngrove, Rio Nido, Stewarts Point, Vineburg, Valley Ford, The Sea Ranch Glen Ellen, Graton, Stewarts Point	Santa Rosa	3965 Occidental Rd	95401	(707) 579-6477	<a href="mailto:EDLHCCDSantaRosa@pge.com">EDLHCCDSantaRosa@pge.com</a>

*Not cited in Cal. Rest. Ass'n v. City of Berkeley  
No. 21-16278am archived December 27, 2023*

Table FM-1 Service Planning Office and Inspection Desk Contact Information (continued)

Service Planning Office and Inspection Desk Contact Information							
Region	Division	Cities Covered	Work Center	Address	Zip Code	Phone	Email
Region 2: North Valley and Sierra	North Valley	Chico, Oroville, Lake Almanor, Willows, Orland, Paradise	Chico	460 Rio Lindo Ave	95926	(530) 894-4707	<a href="mailto:EDLHCCDChico@pge.com">EDLHCCDChico@pge.com</a>
Region 2: North Valley and Sierra	North Valley	Redding, Cottonwood, Igo, Ono, Shasta, City of Shasta Lake, Lakehead-O'Brien, Anderson, Burney, Johnson Park, Bieber, New Bieber, Old Station, Hat Creek, Palo Cedro, Bella Vista, Shingletown, French Gulch, Whiskeytown, Round Mountain, Montgomery Creek, Millville, Oak Run, Whitmore, Mountain Gate, Big Bend, McArthur, Fall River Mills, Little Valley, Cassel, Corning, Paskenta, Red Bluff, Mineral, Paynes Creek, Platina, Manton, Vina, Los Molinos, Gerber, Tehama, Flournoy, Wildwood in SE Trinity County only, Lassen County	Redding	3600 Meadow View Dr	96002	(530) 246-6537  (530) 246-6527	<a href="mailto:EDLHCCDRedding@pge.com">EDLHCCDRedding@pge.com</a>
Region 2: North Valley and Sierra	Sacramento	Sacramento, Elk Grove, Rancho Cordova, Folsom, Citrus Heights, Carmichael, Fair Oaks, North Highlands, Galt, Orangevale, Antelope, Rio Linda, Gold River, Rosemont, Rancho Murieta	Sacramento	5555 Florin Perkins Rd	95826	(916) 386-5112	<a href="mailto:EDLHCCDSacramento@pge.com">EDLHCCDSacramento@pge.com</a>
Region 2: North Valley and Sierra	Sacramento	Vacaville, Fairfield, Dixon, Rio Vista, Allendale, Suisun City, Birds Landing, Woodland, Davis, Yolo, Winters, Knights Landing, Clarksburg, Dunnigan, Guinda, Esparto, West Sacramento	Vacaville	158 Peabody Rd	95688	(707) 449-5791  (707) 449-5702	<a href="mailto:EDLHCCDVacaville@pge.com">EDLHCCDVacaville@pge.com</a>
Region 2: North Valley and Sierra	Sacramento	Arbuckle, Butte City, College City Colusa, Dunnigan, Grimes, Maxwell, Meridian, Williams, East Nicolaus, Elverta, Live Oak, Nicolaus, Pleasant Grove, Rio Oso, Sutter Yuba City, Browns Valley, Dobbins, Linda, Marysville, Plumas Lake, Arboga, Olivehurst, Oregon House, Smartsville, Big Oak Valley, Wheatland	Marysville	29 4th St	95901	(530) 634-6442	<a href="mailto:EDLHCCDMarysville@pge.com">EDLHCCDMarysville@pge.com</a>

Table FM-1 Service Planning Office and Inspection Desk Contact Information (continued)

Service Planning Office and Inspection Desk Contact Information							
Region	Division	Cities Covered	Work Center	Address	Zip Code	Phone	Email
Region 2: North Valley and Sierra	Sierra	Auburn, Alta, Soda Springs, Dutch Flat, Colfax, Meadow, Vista, Foresthill, Cool, Georgetown, Garden Valley, Newcastle, Penryn, Loomis, Granite Bay, Sheridan, Pleasant Grove, Rocklin, Roseville, Lincoln, Grass Valley	Auburn	12840 Bill Clark Way	95602	(530) 889-3271	<a href="mailto:AuburnInspectionRequests@pge.com">AuburnInspectionRequests@pge.com</a>
Region 2: North Valley and Sierra	Sierra	Placerville, Diamond Springs, El Doarado, Camino, Somerset, Grizzly Flats, Pollock Pines, Kyburz, Twin Bridges, Strawberry Shingle Springs, Rescue, Lotus, Coloma, Cameron Park, El Dorado Hills	Placerville	4636 Missouri Flat Rd	95667	(530) 621-7275	<a href="mailto:EDLHCCDPlacerville@pge.com">EDLHCCDPlacerville@pge.com</a>
Region 3: Bay Area	Diablo	Antioch, Pittsburg, Bay Point, Byron, Knightsen, Bethel Island, Brentwood, Oakley, Discovery Bay	Antioch	2111 Hillcrest Ave	94509	(925) 779-7716	<a href="mailto:Antiochinspectionlogs@pge.com">Antiochinspectionlogs@pge.com</a>
Region 3: Bay Area	Diablo	Concord, Walnut Creek, Pleasant Hill, Martinez, Briones, Clyde, Danville, Alamo, Clayton, Blackhawk, Diablo, Moraga, Orinda, Lafayette, Pacheco	Concord	1030 Detroit Ave	94518	(925) 779-7716	<a href="mailto:Antiochinspectionlogs@pge.com">Antiochinspectionlogs@pge.com</a>
Region 3: Bay Area	East Bay	Oakland, Emeryville, Piedmont, Alameda	Oakland	4801 Oakport St	94601	(510) 437-2088	<a href="mailto:InspectionDeskOakport@pge.com">InspectionDeskOakport@pge.com</a>
Region 3: Bay Area	East Bay	Richmond, El Sobrante, El Cerrito, Berkeley, Hercules, Crockett, Kensington, San Pablo, Rodeo, Albany, Pinole, Port Costa	Richmond	1100 South 27th St	94804	(510) 231-2939	<a href="mailto:InspectionDeskRichmond@pge.com">InspectionDeskRichmond@pge.com</a>
Region 3: Bay Area	Mission	Fremont, Newark, Union City, Hayward, San Leandro, San Lorenzo, Castro Valley, Dublin, Livermore, Pleasanton, San Ramon, Sunol	Hayward	24300 Clawiter Rd	94538	(510) 784-3317	<a href="mailto:missiondivisioninspectiondesk@pge.com">missiondivisioninspectiondesk@pge.com</a>
Region 3: Bay Area	Peninsula	Atherton, Belmont, Brisbane, Broadmoor Village, Burlingame, Colma, Daly City, East Palo Alto, El Granada, Emerald Hills, Foster City, Half Moon Bay, Ladera, La Honda, Loma Mar, Menlo Park, Millbrae, Miramar, Montara, Moss Beach, Pacifica, Stanford, Palomar Park, Pescadero, Portola Valley, Princeton, Redwood City, San Bruno, San Carlos, SFO Airport, San Mateo, San Gregorio, South San Francisco, Woodside	San Carlos	275 Industrial Rd	94070	(650) 598-7353	<a href="mailto:PNSPInspections@pge.com">PNSPInspections@pge.com</a>
Region 3: Bay Area	San Francisco	San Francisco	San Francisco	2180 Harrison St	94110	(415) 695-7519	<a href="mailto:sanfranciscotrenchinspections@pge.com">sanfranciscotrenchinspections@pge.com</a>

Table FM-2 Service Planning Office and Inspection Desk Contact Information (continued)

Service Planning Office and Inspection Desk Contact Information							
Region	Division	Cities Covered	Work Center	Address	Zip Code	Phone	Email
Region 4: Central Coast	Central Coast	Salinas, Watsonville, Santa Cruz, Monterey, King City, Hollister, Castroville	Salinas	356 Alisal St	93901	(831) 784-3614	<a href="mailto:CentralCoastInspect@pge.com">CentralCoastInspect@pge.com</a>
Region 4: Central Coast	De Anza	Los Altos, Los Altos Hills, Cupertino, Sunnyvale, Mountain View, Campbell, Los Gatos, Saratoga, Monte Sereno, and some areas in San Jose	Cupertino	10900 N Blaney	95014	(408) 725-2202	<a href="mailto:DASPIInspections@pge.com">DASPIInspections@pge.com</a>
Region 4: Central Coast	Los Padres	San Luis Obispo, Pismo Beach, Grover Beach, Arroyo Grande, Oceano, Los Osos, Morro Bay, Cambria, Cayucos, San Simeon, Nipomo, Santa Maria, Orcutt, Santa Ynez, Buellton, Los Olivos, Los Alamos, Solvang, Sisquoc, Lompoc, Guadalupe, Casmalia, Carpenteria	San Luis Obispo	5325 S. Higuera	93401	(805) 546-5247	NA
Region 4: Central Coast	Los Padres	Templeton, Atascadero, Santa Margarita, Shandon, Creston, Paso Robles, San Ardo, Bradley, San Miguel, Adelaide, Lockwood, Carrisa Plains, Cholame, Parkfield, Parkhill	Templeton	160 Cow Meadow PI	93446	(805) 434-4460	NA
Region 4: Central Coast	Los Padres	Nipomo, Santa Maria, Orcutt, Santa Ynez, Buellton, Los Olivos, Los Alamos, Solvang, Sisquoc, Lompoc, Guadalupe, Casmalia, Carpenteria	Santa Maria	2445 Skyway Dr	93455	(805) 346-2241	NA
Region 4: Central Coast	San Jose	San Jose, Alviso, Milpitas, San Clara, San Martin, Morgan Hill, Gilroy	San Jose	308 Stockton Ave	95126	(408) 299-1024	<a href="mailto:SJSPInspections@pge.com">SJSPInspections@pge.com</a>
Region 5: Central Valley	Fresno	Fresno, Selma, Dinuba, Lemoore, Coalinga, Corcoran, Auberry, Avenal, Caruthers, Clovis, Fowler, Friant, Hanford, Huron, Kerman, Kettleman City, Kingsburg, Orange Cove, Prather, Reedley, San Joaquin, Sanger, Shaver Lake, Tulare, Visalia	Fresno	3580 E California Ave	93760	(559) 263-7312	<a href="mailto:fresnodivisioninspectionrequest@pge.com">fresnodivisioninspectionrequest@pge.com</a>
Region 5: Central Valley	Kern	Bakersfield, Buttonwillow, McFarland, Tupman, Taft, Cuyama, Maricopa, McKittrick, Shafter, Wasco, Lost Hills, Valley, Ridgecrest, Lamont, Arvin, Lebec	Bakersfield	4101 Wible Rd	93313	(661) 398-5711	<a href="mailto:kerninspections@pge.com">kerninspections@pge.com</a>

Table FM-1 Service Planning Office and Inspection Desk Contact Information (continued)

Service Planning Office and Inspection Desk Contact Information							
Region	Division	Cities Covered	Work Center	Address	Zip Code	Phone	Email
Region 5: Central Valley	Stockton	Stockton, Tracy, Angels Camp, Lathrop, Mountain House, Ripon, Escalon, Manteca, Mokelumne City, Clements, Wallace, Lodi, Thornton, Acampo, Youngstown, Woodlake, Collierville, Lockeford, Banta, Waterloo, Burnham, Linden, Farmington, Oakdale, Knights Ferry, Riverbank, Victor, Morada, French Camp	Stockton	3136 Boeing Way	95206	(209) 272-8643	<a href="mailto:stocktondivisioninspectionrequest@pge.com">stocktondivisioninspectionrequest@pge.com</a>
Region 5: Central Valley	Yosemite	Merced, Madera, Los Banos, Oakhurst, Mariposa, Santa Nella, Gustine, Dos Palos, Mendota, Firebaugh, Atwater, Winton, Livingston, Planada, Snelling, La Grange, Legrand, Bass Lake, Ahwahnee, North Fork Coarsegold, Raymond, Oakdale, Jamestown, Sonora	Merced	4155 East Childs Ave	93725	(209) 726-6373	<a href="mailto:YosemiteDivisionInspectionRequest@pge.com">YosemiteDivisionInspectionRequest@pge.com</a>
Region 5: Central Valley	Yosemite	Modesto, Newman, Gustine, Patterson, Turlock, Ceres, Oakdale, Riverbank, Escalon, Sonora, Jamestown, Delhi, Knights Ferry, Waterford, Salina, Crows Landing, Tuolumne	Modesto	1524 North Carpenter Rd	95351	(209) 576-6562	<a href="mailto:YosemiteDivisionInspectionRequest@pge.com">YosemiteDivisionInspectionRequest@pge.com</a>

Cited in Cal. Rest. Ass'n v. City of Berkeley  
 No. 21-16278am archived December 27, 2023





## Table of Contents

Contents	Page
<b>Section – General</b>	
1.1. Purpose .....	1-2
1.2. Permits and Inspections .....	1-
1.2.1 Pre-Construction Meetings .....	1-
1. . Applying for Building and Renovation Services .....	1-
1. . Changes in Requirements .....	1-6
1. . Additional Nonresidential (Commercial and Industrial) Service Information .....	1-
1.6. Design and Construction .....	1-8
1.6.1 PG&E's Responsibilities .....	1-8
1.6.2 Applicant's Responsibilities .....	1-8
1.6. . Providing Access to PG&E Electric Facilities .....	1-8
1.6. . Installing Transformers .....	1-9
1.6. . Underground Electric Service Extensions .....	1-10
1. . Connecting and Sealing Services .....	1-10
1.8. Access to an Applicant's Residence, Building, or Property .....	1-11
1.9. Overhead Electric Lines .....	1-12
1.10. Underground Electric Lines and Gas Pipelines .....	1-1
1.10.1 Safe Landscaping Near Underground Facilities .....	1-1
1.11. PG&E Safety Training Resources .....	1-1
1.12. SmartMeter™ Program .....	1-1
1.1 . PG&E Online (Website) .....	1-1
1.1 .1. Electric and Gas Service Requirements Manual (aka Greenbook) .....	1-1
1.1 .2. Rates and Tariffs .....	1-1



Table of Contents

Contents	Page
<b>Section – General (continued)</b>	
1.1 . Determining the Electric Service Rating .....	1-1
1.1 . Changing an Applicant’s Approved Project or Existing Service Loads .....	1-20
1.16. Upgrading, Replacing, and Relocating Electric Facilities, or Adding Power Generation Sources .....	1-20
1.16.1. Upgrading Electric Facilities .....	1-21
1.16.2. Replacing Electric Facilities with Like-for-Like .....	1-21
1.16. . Relocating Electric Facilities .....	1-2
1.16. . Adding Power Generation .....	1-2
1.1 . Standard Electric Service Voltage and Load Limitations .....	1-2
1.1 .1. Single-Phase Service .....	1-2
1.1 .2. Three-Phase Service .....	1-2
1.1 . . Mixed-Use Projects .....	1-2
1.18. Wholesale Distribution Tariff ( DT) Interconnections .....	1-2
1.19. Harmful Wave Form .....	1-26
<b>Section 2 – Gas Service</b>	
2.1. Scope .....	2-1
2.2. Procedures for Establishing Gas Service .....	2-1
2.2.1. Establishing New Gas Service .....	2-1
2.2.2. Relocating or Adding Load to an Existing Service .....	2-
2. . Gas Service .....	2-
2. .1. General .....	2-
2. .2. Branch Service Pipe .....	2-10
2. . . Curb Valves .....	2-10
2. . . Joint Utility Service Trenches .....	2-11

cited in Cal. Rest. Ass'n v. City of Berkeley  
 No. 21-16278 am archived December 27, 2023

Contents	Page
<b>Section 2 – Gas Service (continued)</b>	
2. . . Multiple Buildings Located on One Lot . . . . .	2-1
2. .6. Mobile Home Parks . . . . .	2-18
2. . Set Requirements for Gas Meters . . . . .	2-18
2. .1. Gas Pressure . . . . .	2-18
2. .2. Gas Meter-Set Locations . . . . .	2-20
2. . Applicant-Owned and Installed Gas Service Piping (e.g., Mains), Valves, and Automatic Shut-Off Devices . . . . .	2- 9
2. .1. Service Delivery Point for the Gas Supply . . . . .	2- 0
2. .2. Applicant-Owned Meter and Pipe . . . . .	2- 1
2. . . Electrically Bonding and Grounding Gas Pipe . . . . .	2-
2. . . Applicant-Owned Protective Equipment . . . . .	2-
<b>Section 3 – Electric Service: Underground</b>	
.1. Scope . . . . .	-1
.2. General Information . . . . .	-1
.2.1. Safety Reminder . . . . .	-1
.2.2. Establishing Underground Electric Service Responsibilities . . . . .	-2
.2. . Installing Ground Rods . . . . .	-
.2. . Installing Equipment Pads . . . . .	-
.2. . Installing Overhead and Underground Service for Two or More Buildings on One Lot . . . . .	-6
.2.6. Inspecting and Approving Overhead and Underground Services . . . . .	-
.2. . Easements for PG&E Facilities . . . . .	-
.2.8. Clearances Around PG&E Facilities . . . . .	-8

Table of Contents

---

Contents	Page
----------	------

---

**Section 3 – Electric Service    nderground (continued)**

. .    nderground Service Installation    equirements .....	-8
. .1.    Installing Services from    nderground Distribution Systems .....	-8
. .2.    Installing Services from Overhead Distribution Systems .....	-9
. . .    Installing Conduit for    nderground Service .....	-11
. . .    Installing PG&E-Only Service Trenches .....	-1
. . .    Installing Offsets .....	-1
. .6.    Selecting Backfill .....	-1
. . .    Providing Drainage from the Conduit System .....	-16
. .8.    Installing    oint    tility Service Trenches .....	-1
. .9.    Providing a Service-Termination Facility .....	-19
. .10.    Bioswales and    arge,    et    eations .....	-20
. .11.    eplacing    on Standard    nderground Services .....	-20
. .    Electric    nderground Documents .....	-20
. .    Mandrels .....	-20

cited in Cal. Rest. Ass'n v. City of Berkeley  
 No. 21-16278am archived December 27, 2023

**Section    – Electric Service    Overhead**

.1.    Scope .....	-1
.2.    General .....	-1
.2.1.    Safety    eminder .....	-1
. .    ocating Overhead Services .....	-1
. .1.    Point of Attachment .....	-1
. .2.    Two or More Buildings on One    ot .....	-

Contents	Page
<b>Section – Electric Service Overhead (continued)</b>	
. . . Service Drop Clearances . . . . .	-
. .1. Vertical Clearance for Residential, Overhead Service . . . . .	-
. .2. Clearance Above Buildings . . . . .	-
. . . Clearance at the Residential Point of Attachment . . . . .	-8
. . . Vertical Clearance on Nonresidential Property . . . . .	-10
. . . Clearances for a Nonresidential Building Service Drop Using Cable or Equally Insulated, Open-Wire Service Conductors . . . . .	-11
. .6. Clearances Around Doors and Windows . . . . .	-1
. . . Clearance Between Service Drop Wires . . . . .	-1
. .8. Clearance from Applicant-Owned Service Poles . . . . .	-1
. . . Service Attachments . . . . .	-1
. .1. Attaching Low-Voltage, Residential, Overhead Service Drops . . . . .	-1
. .2. Attaching Low-Voltage, Nonresidential, Overhead Service Drops . . . . .	-1
. . . Special Service Attachment Requirements: Areas Subject to Heavy Snow Loading . . . . .	-19
.6. Attachment Structures (Periscopes) . . . . .	-21
.6.1. Periscope Clearances and Bracing Requirements . . . . .	-22
. . . Service Weatherheads . . . . .	-2
.8. Service-Entrance Conductors . . . . .	-2
.9. Applicant-Owned, Installed, or Furnished Wood Poles . . . . .	-2
.10. Required Vegetation Clearances . . . . .	-2
.10.1. General Requirements . . . . .	-2
.10.2. Planning Requirements . . . . .	-29
.10. . Existing Overhead Lines Adjacent to Developments . . . . .	- 0

Table of Contents

Contents	Page
----------	------

**Section – Electric Service Overhead (continued)**

.10. .	Line Extensions .....	- 1
.10. .	Primary Overhead Distribution Poles in Commercial Orchard Installations .....	- 1
.10.6.	Removing vegetation near Existing, High-voltage, Energized Lines .....	- 1

**Section – Electric Metering General**

.1.	Scope .....	-1
.2.	General Conditions and Responsibilities .....	-1
.2.1.	Approved Metering and Service-Termination Equipment .....	-1
.2.2.	Drawing Submittal Requirements for Metering and Service Termination Equipment .....	-1
.2. .	Applicant Responsibilities .....	-
.2. .	Requirements for Installing Secondary Terminations (0-600 volts) in Metering Equipment requiring CTs .....	-
. .	Electric Meters: General Location Requirements .....	-
. .1.	Basic Meter Location Requirements .....	-6
. .2.	Prohibited Meter and Service Equipment Locations .....	-
. . .	Locating and Grouping Multiple Meters .....	-8
. . .	Electric Meter and Service Termination Equipment Rooms .....	-8
. .	Meter Heights, Clearances, Enclosures, and Protection .....	-1
. .1.	Meter Heights .....	-1
. .2.	Meter Cabinet Enclosure Clearances .....	-1
. . .	Meter Set Clearance Requirements .....	-16
. . .	Working Space .....	-1
. . .	Barricades .....	-21

cited in Cal. Rest. Ass'n v. City of Berkeley  
 No. 21-16278am archived December 27, 2023

Contents	Page
<b>Section – Electric Metering General (continued)</b>	
.6. Meter Protection .....	-2
. . Meter Identification and Seals .....	-2
. .1. Properly Identifying and Marking Meters .....	-2
. .2. Sealing Meters and Metering Equipment .....	-26
. . . Locking Provisions .....	-26
.6. Meter Types and Connections .....	-26
.6.1. Installing a Meter Socket Adapter for Overhead-to-Underground Conversion .....	-29
.6.2. Installing Non-Allowed and Unauthorized Customer Equipment ..	-29
.6. . Fire-Pump Connections .....	-29
. . Main Service Disconnects and Switching Sequences .....	- 1
. .1. Main Service Disconnects .....	- 1
. .2. Main Service Disconnect Switch Rated for Amperes Interrupting Capacity (AIC) .....	- 1
. . . Arc Flash Assessment .....	- 2
. . . Electronic Trip Circuit Breakers .....	- 2
. . . Meter and Main Service Switch Sequence .....	-
.8. Grounding .....	-
.9. Temporary Service .....	- 8
.9.1. Temporary Service Using Permanent Service Panels .....	- 8
.9.2. Temporary-Service Metering Pedestal .....	- 9
.9. . Temporary Plug-In Service .....	- 1

Table of Contents

---

Contents	Page
----------	------

---

**Section – Electric Metering General (continued)**

.10. Connecting on-tility Power Sources to tility Services .....	- 2
.10.1. Specific Interconnection equirements for Services p to 600 olts .....	- 2
.10.2. arning Statements and abels for Interconnected Services .....	-
.10. . iolation .....	- 8
.10. . eferences for Customer Generation .....	- 8
.11. Plug-In Electric ehicle Interconnections .....	- 8

**Section – Electric Metering Residential**

6.1. Scope .....	6-1
6.2. Residential Electric Service: Specifications and equirements .....	6-1
6.2.1. Service Classes .....	6-1
6.2.2. Test-Bypass Facilities .....	6-1
6.2. . Electric Meter Socket Covers and Seals .....	6-2
6. . Meter ocations .....	6-2
6. .1. Installing tility Services to Mobile omes .....	6-
6. . Services .....	6-
6. .1. Single Meter: nderground Service .....	6-
6. .2. Single Meter: Overhead Service .....	6-8
6. . . Single Meter: Combination Overhead and nderground Service Equipment .....	6-12
6. . . Multiple Meters .....	6-1

cited in Cal. Rest. Ass'n v. City of Berkeley  
 No. 21-16278am archived December 27, 2023

Contents	Page
<b>Section Electric Metering Nonresidential, Industrial, and Agricultural</b>	
.1. Scope .....	-1
.2. Service Specifications and Requirements .....	-1
.2.1. Permitted Types of Electric Service .....	-1
.2.2. Required Test-Bypass Facilities .....	-1
.2.3. Required Approvals for Meter Equipment without Test-Bypass Facilities .....	-2
.2.4. Meter Locations .....	-2
.2.5. Services, 0 Amps Through 200 Amps, Single Applicant, Overhead and Underground .....	-
.2.6. Services, Over 200 Amps, Single Applicant, Underground .....	-
.2.7. Services, Over 200 Amps, Single Applicant, Overhead .....	-12
.2.8. Multi-Applicant Meter Installations .....	-1
<b>Section – Electric Metering Pedestals</b>	
8.1. Scope .....	8-1
8.2. Residential Electric Metering Pedestals .....	8-1
8.3. Nonresidential Single-Meter Service Pedestals, 100 – 200 Amps .....	8-2
8.4. Nonresidential Dual-Meter Service Pedestals, 100 – 200 Amps .....	8-6
8.5. Nonresidential Current-Transformer Rated Pedestals, 100 – 600 Amps 1 or 2, 800 Amps .....	8-11
<b>Section Electric Metering Components and Cable Terminating</b>	
9.1. Scope .....	9-1
9.2. Test Blocks for Self-Contained Metering, 0 Amps Through 225 Amps .....	9-1
9.3. Test Switch Mounting Base Detail .....	9-
9.4. Separate CT Cabinet, 201 Amps and Above, Single Phase and Three Phase .....	9-



Table of Contents

Contents	Page
----------	------

Section 9 Electric Metering Components and Cable Terminating (continued)

9. .	CT Mounting Base, 201 Amps Through 600 Amps	9-1
9.6.	Alternate CT Mounting Base, One Phase or Three Phase	9-6
9. .	Bused CT Cabinet, - Wire Service, 201 Amps Through 600 Amps	9-8
9.8.	Bused CT Cabinet, - Wire Service, 600 Amps	9-9
9.9.	Meter Box for Transformer- Rated Metering	9-10
9.10.	Underground Service Cable-Termination Compartments or Sections	9-12
9.11.	Approved Service-Terminal Conductor Connectors	9-1

Section 10 Electric Switchboards 600 Volts Through 15,000 Volts

10.1.	Scope	10-1
10.2.	General Requirements	10-1
10. .	Switchboard Service Section	10-
10. .1.	Standard Switchboard Service Section	10-
10. .2.	Specifically Engineered Switchboard Service Sections	10-
10. . .	Requirements for All Switchboard Service Sections	10-
10. . .	Standard Switchboard CT Compartment, 600 Amps Through 1,200 Amps, Single-Phase or Three-Phase, - Wire Service	10-
10. . .	Standard Switchboard CT Compartment, 600 Amps Through 1,200 Amps, Three-Phase, - Wire and - Wire Services	10-9
10. .6.	Standard Switchboard CT Compartment, 1,001 Amps Through 1,500 Amps, Single-Phase or Three-Phase, - Wire Service	10-11
10. . .	Standard Switchboard, CT Compartment, 1,001 Amps Through 1,500 Amps, Three-Phase, - Wire Service	10-1
10. .8.	Standard Switchboard CT Compartment, 1,501 Amps and Larger, Three-Phase, - Wire Service	10-1
10. .9.	Standard Switchboard CT Compartment, 1,501 Amps and Larger, Three-Phase, - Wire or - Wire Service	10-1

*cited in Csl. Rest. Ass'n v. City of Berkeley No. 21-16278am archived December 27, 2023*

Contents	Page
<b>Section 0 Electric Switchboards 0 olts Through 00 olts (continued)</b>	
10.10. Removable Link Assemblies .....	10-19
10.11. Standard Section for Self-Contained Meter Sockets, 0 Amps Through 22 Amps, Installed in Switchboards: Nonresidential ...	10-2
10.12. Service Terminations for Underground Services .....	10-26
10.1. Underground, Service-Termination Pull Section ( Located Below Ground Level) .....	10-28
10.1. Underground, Cable-Terminating Facilities in Pull Boxes or Pull Sections .....	10-
10. Meter and Switch Sequence Requirements .....	10-
10. Metering Transformer Compartments .....	10- 8
10.6. Meter Panels .....	10- 8
10. Transformer- Rated and Self-Contained Switchboards .....	10-
10.8. Adding Metering Equipment to Existing Switchboards .....	10-
<b>Section Electric Switchboards 0 olts Through 2 ,000 olts, and Primary Services</b>	
11.1. Scope .....	11-1
11.2. General Requirements .....	11-1
11. Specific Requirements for High-Voltage Switchboards .....	11-2
11. Interconnection Requirements and Primary Services .....	11-1
11. Primary Switchgear Located Below Ground Level .....	11-1
<b>Appendix A Acronyms and Glossary .....</b>	<b>A</b>
<b>Appendix Electric and Gas Service Documents .....</b>	
<b>Appendix Electric and Gas Engineering Documents .....</b>	<b>-</b>

Table of Contents

This Page Intentionally Left Blank

*cited in Cal. Rest. Ass'n v. City of Berkeley  
No. 21-16278am archived December 27, 2023*

## List of Tables

Contents	Page
<b>Section</b>	<b>General</b>
Table 1-1	SA Color Coding ..... 1-1
Table 1-2	Minimum Safe Working Distances (Scaffolds, Equipment, Tools, Structures, and People) ..... 1-12
Table 1-	Minimum Safe Working Distances (Boom-Type Lifting or Hoisting Equipment) ..... 1-1
<b>Section 2</b>	<b>Gas Service</b>
Table 2-1	Minimum Separation and Clearance Requirements for Trenches ..... 2-1
Table 2-2	Dimensions to Figure 2-2 ..... 2- 1
<b>Section 3</b>	<b>Electric Service Underground</b>
Table -1	Minimum Separation and Clearance Requirements for Trenches ..... -19
Table -2	Mandrel Dimensions, Part Numbers, and Order Codes ..... -2
Table -	Businesses That Sell or Rent Mandrels ..... -2
<b>Section</b>	<b>Electric Service Overhead</b>
Table -1	Minimum Clearances Over Swimming Pools ..... -6
Table -2	Minimum Allowable Clearance of Insulated Service Drops from Buildings 0 Volts Through 0 Volts ..... -
Table -	Vertical Clearance from the Ground on Nonresidential Property ..... -10
Table -	Maximum Distance “ ” (Inches from the Service Attachment to the Top Periscope Support) ..... -20
Table -	Maximum Mast Height Above the Roof Without Bracing ..... -2

Contents		Page
<b>Section Electric Metering General</b>		
Table -1	Meter Cabinet Enclosure Clearance Dimensions .....	-1
Table -2	Working Space Dimensional Requirements .....	-18
Table -	Bollard Post Materials .....	-2
Table -	Meter Socket Requirements (Number of Poles) .....	-2
Table -	Grounding Requirements for Wall-Mounted Panels .....	- 8
Table -6	Requirements for AC Disconnect Switches .....	-
Table -	Customer Generation References .....	- 8
<b>Section Electric Metering Residential</b>		
Table 6-1	Residential (0 Amps–22 Amps) Enclosure .....	6-
Table 6-2	Residential Combination (O / G) Meter Panel .....	6-1
Table 6-	Dimension Specifications for Multimeter Installations .....	6-19
<b>Section Electric Metering Pedestals</b>		
Table 8-1	Minimum Dimensions (Inches) .....	8-
Table 8-2	Minimum Dimensions (Inches) .....	8-
Table 8-	CT Pedestal Approved Manufacturer’s Model Numbers and Figures .....	8-12
<b>Section Electric Metering Components and Cable Terminating Capabilities</b>		
Table 9-1	CT Cabinet Minimum Dimensions .....	9-
Table 9-2	Ringed Meter Panel Requirements .....	9-11
Table 9-	Minimum Wall-Mounted Pull-Section Dimensions: Residential and Nonresidential, Single-Phase or Three-Phase .....	9-1
Table 9-	Minimum Pad-Mounted (Floor-Standing) Switchboard Pull-Section Dimensions: Residential and Nonresidential, Single-Phase and Three-Phase .....	9-1
Table 9-	Approved, Compression-Type, Service-Terminal Connectors .....	9-18

cited in Cal. Rest. Ass'n v. City of Berkeley  
 No. 21-16278am archived December 27, 2023

Contents	Page
<b>Section 0</b>	<b>Electric Switchboards 0 volts Through 100 volts</b>
Table 10-1	Minimum Bottom-Fed Pull-Section Dimensions ..... 10-2
Table 10-2	Pull-Section Dimensions (Minimums) Below Ground Level ..... 10- 1
Table 10-	Dual-Socket, Ringed, Meter-Panel Requirement ..... 10- 9
Table 10-	Adding up Meter Section Ampacities ..... 10- 6
<b>Section</b>	<b>Electric Switchboards 100 volts Through 2,000 volts, and Primary Services</b>
Table 11-1	Bill of Materials for Concrete Pad ..... 11-
Table 11-2	Dimensions for High-Voltage Meter Enclosures ..... 11-11
<b>Appendix A</b>	<b>Acronyms and Glossary ..... A</b>
<b>Appendix</b>	<b>Electric and Gas Service Documents ..... 11-6</b>
Table B-1	Plant Matrix for Stockton, Yosemite, Fresno, and Kern Divisions ..... 11-6
Table B-2	Plant Matrix for San Francisco, Peninsula, and DeAnza Divisions ..... 11-
Table B-	Plant Matrix for San Jose, Central Coast, and Los Padres Divisions ..... 11-8
Table B-	Plant Matrix for North Valley, Sierra, and Sacramento Divisions ..... 11-9
Table B-	Plant Matrix for Diablo, Mission, and East Bay Divisions ..... 11-10
Table B-6	Plant Matrix for North Coast and North Bay Divisions ..... 11-11
Table B-	Do Not Plant These Trees Under or Within 1 Feet of Overhead Power Lines ..... 11-12
<b>Appendix</b>	<b>Electric and Gas Engineering Documents ..... 11-1</b>
Table C-1	Gas Design Standards ..... 11-1
Table C-2	Electric Engineering Documents ..... 11-2

This Page Intentionally Left Blank

*cited in Cal. Rest. Ass'n v. City of Berkeley  
No. 21-16278am archived December 27, 2023*

## List of Figures

Contents	Page
<b>Section – General</b>	
Figure 1-1 Plate Mounting Label Example: Pad-Mounted Electrical Switchboard or Termination Enclosure . . . . .	1-19
Figure 1-2 Plate Mounting Label Example: Wall-Mounted Electrical Meter Panel or Termination Enclosure . . . . .	1-19
Figure 1- Electric Panel Placement of Allowed when Over a PG&E SmartMeter Gas Meter Set . . . . .	1-2
<b>Section 2 – Gas Service</b>	
Figure 2-1 Typical Gas Service Installation . . . . .	2-6
Figure 2-2 Gas-Only Service Trench . . . . .	2-9
Figure 2- Typical Gas Bell Hole-Plan View . . . . .	2-9
Figure 2- Typical Bell Hole Depth-Profile View . . . . .	2-9
Figure 2- Typical Joint-Service Trench . . . . .	2-12
Figure 2-6 Separate Gas Services for Two Buildings on a Single Lot . . . . .	2-1
Figure 2- Separate Gas Services for Two Buildings on a Corner Lot . . . . .	2-16
Figure 2-8 Apartments with Grouped Meter Locations . . . . .	2-1
Figure 2-9 Individually Metered Buildings . . . . .	2-1
Figure 2-10 Property Line Installation . . . . .	2-21
Figure 2-11 Acceptable Locations for Gas Meter Installations . . . . .	2-2
Figure 2-12 Acceptable Meter Locations for Mobile Home Parks . . . . .	2-2
Figure 2-1 Flex-Use Meter Set Residential and Small Commercial . . . . .	2-2
Figure 2-1 Typical Residential Gas Meter Connection . . . . .	2-28
Figure 2-1 Typical Gas Meter Connection for 00 to 1,000 Class Meters . . . . .	2-29
Figure 2-16 Gas Meter Connection Using a 1. M or M Rotary Gas Meter . . . . .	2- 0
Figure 2-1 Gas Meter Connection Using a M or M Rotary Gas Meter . . . . .	2- 1
Figure 2-18 Gas Meter Connection Using an 11M or 16M Rotary Gas Meter . . . . .	2- 2
Figure 2-19 Electric and Gas Meter Set Separation Dimensions and Clearances . . . . .	2-



## List of Figures

Contents	Page
<b>Section 2 – Gas Service (continued)</b>	
Figure 2-20 Gas Meter Set Clearance From Building Openings . . . . .	2- 6
Figure 2-21 Gas Regulator Set Clearance Requirement from Air-Intake and Exhaust Fans . . . . .	2- 8
Figure 2-22 Clearance Requirements for an Existing Electric Meter/Panel . . . . .	2- 8
Figure 2-2 Dimensions for Typical, Residential, Multimeter Installations . . . . .	2- 0
Figure 2-2 Typical Detached Enclosure . . . . .	2- 2
Figure 2-2 Typical Enclosure Dimensions . . . . .	2- 2
Figure 2-26 Accessed, Individual Meter Cabinet for Gas and Electric Meter Installations . . . . .	2- 2
Figure 2-2 Cabinet Dimensions for Multiple, Residential Gas Meters . . . . .	2- 2
Figure 2-28 Typical Residential Installations . . . . .	2- 1
Figure 2-29 Recommended, Applicant-Owned, Aboveground Meter and Pipe . . . . .	2- 2
<b>Section 3 – Electric Service Underground</b>	
Figure -1 Locations of Underground Electric Service-Termination and Meter Facilities . . . . .	-
Figure -2 Service Conduit Layout Top View . . . . .	-6
Figure - PG&E Trench and Equipment in P E – Example . . . . .	-8
Figure - Underground-to-Underground Service Connection . . . . .	-9
Figure - Overhead-to-Underground Service Connection . . . . .	-10
Figure -6 Typical Joint Service Trench . . . . .	-18
Figure - PG&E Electric and Gas Service Trench . . . . .	-18
Figure -8 Flexible Steel Mandrel . . . . .	-22
<b>Section – Electric Service Overhead</b>	
Figure -1 Preferred and Alternate Locations for the Overhead Service Drop Attachment . . . . .	-2
Figure -2 Ground Clearances for Supply Service Drops, 0 Volts Through 0 Volts, Residential Installations (Required by the CP C) . . . . .	-

Contents	Page
<b>Section – Electric Service Overhead, continued</b>	
Figure - Minimum Clearance for All Drops Above or Adjacent To Swimming Pools .....	-6
Figure - Nonmetallic Roof .....	-
Figure - Clearance at the Residential Point of Attachment .....	-9
Figure -6 Clearance at the Residential Point of Attachment .....	-9
Figure - Clearance at the Residential Point of Attachment .....	-9
Figure -8 Clearance at the Residential Point of Attachment .....	-9
Figure -9 Clearance at the Residential Point of Attachment .....	-9
Figure -10 Clearance at the Residential Point of Attachment .....	-9
Figure -11 Clearance at the Residential Point of Attachment .....	-9
Figure -12 Ground Clearances for Supply Service Drops, 0 Volts Through 0 Volts, Industrial and Residential Installations (Required by the CPUC) .....	-11
Figure -1 Clearances for Nonresidential Buildings Using Insulated Conductors (0 Volts - 0 Volts) .....	-1
Figure -1 Clearances for Nonresidential Buildings Using Insulated Conductors (0 Volts - 0 Volts) .....	-1
Figure -1 Clearances for Nonresidential Buildings Using Insulated Conductors (0 Volts - 0 Volts) .....	-1
Figure -16 Clearances for Nonresidential Buildings Using Insulated Conductors (0 Volts - 0 Volts) .....	-1
Figure -1 Clearances for Nonresidential Buildings Using Insulated Conductors (0 Volts - 0 Volts) .....	-1
Figure -18 Clearances for Nonresidential Buildings Using Insulated Conductors (0 Volts - 0 Volts) .....	-1
Figure -19 Clearances for Nonresidential Buildings Using Insulated Conductors (0 Volts - 0 Volts) .....	-1
Figure -20 Clearances for Nonresidential Buildings Using Insulated Conductors (0 Volts - 0 Volts) .....	-1
Figure -21 Clearance Around Windows .....	-1
Figure -22 Clearance Around Doors .....	-1

## List of Figures

Contents	Page
<b>Section – Electric Service Overhead (continued)</b>	
Figure -2 Service Attachment Structure or Service Pole Secured to a Building .....	-1
Figure -2 Service Pole Detached from a Building .....	-1
Figure -2 Open Wire .....	-16
Figure -26 Open Wire or Cable (Open Wire Shown) .....	-16
Figure -2 Open Wire or Cable (Open Wire Shown) .....	-16
Figure -28 Cable (Single Triplex) .....	-16
Figure -29 Cable (Single Spool) .....	-16
Figure - 0 Open Wire or Cable (Cable Shown) .....	-16
Figure - 1 Service Drop Cable, 1/0 and Smaller, Triplex or Quadruplex .....	-18
Figure - 2 New All, 1/0 kcmil 1 to 9 . kcmil Aluminum .....	-18
Figure - New or Existing All, 1/0 kcmil to 9 . kcmil Aluminum .....	-18
Figure - Open Wire Service, 10 9 . kcmil Aluminum .....	-18
Figure - Service Drop Cable .....	-18
Figure - 6 Building Attachment Service Knob .....	-20
Figure - Self-Supported Periscope Attachment Structure .....	-20
Figure - 8 Braced Periscope Attachment Structure .....	-20
Figure - 9 Unbraced Periscope Structure ( Residential and Nonresidential) .....	-2
Figure - 0 Illustration of a 1-Foot Clearance, Low-Growth Tree .....	-28
Figure - 1 Grass and Shrubs Recommended Under Transmission Wires .....	-29
Figure - 2 Alternative Routes to a House Showing High-Voltage Lines and Tree-Clearance Zones .....	- 0
Figure - High-Voltage Marker on Poles and Crossarms .....	- 2
<b>Section – Electric Metering General</b>	
Figure -1 Allowable Locations for Electric Service and Meter Rooms .....	-11
Figure -2 Meter Cabinet Enclosure Clearances .....	-1
Figure - Electric and Gas Meter Set Separation Dimensions and Clearances ..	-16

Contents	Page
<b>Section – Electric Metering General, continued</b>	
Figure - Semi-Flush Meter Installation .....	-19
Figure - Enclosed Meter Installation .....	-19
Figure -6 Preferred Location of Conduits for Indoor and Outdoor Meter Panels and Switchboards .....	-20
Figure - Meter Panel Clearance and Protection from Residential Driveways or Parking Spaces .....	-22
Figure -8 Nonresidential or Multifamily Metering and Service Equipment Clearance and Protection from Vehicle Areas .....	-2
Figure -9 Connection Diagrams for Self-Contained Meter Sockets .....	-28
Figure -10 Connection Diagrams for Transformer-ated Meter Sockets .....	-28
Figure -11 Fire-Pump Equipment Location and Service Connection Options .....	- 1
Figure -12 Circuit Breakers with Electronic Trip Unit .....	-
Figure -1 Single Meter with Main Service Switch .....	-
Figure -1 Single Meter with Multiple Service Switches .....	-
Figure -1 Multimeter Installation without Main Disconnect Switch .....	-
Figure -16 Multimeter Installation with Main Disconnect Switch .....	-
Figure -1 Multiple Remote Switchboard or Meter-Panel Locations .....	-
Figure -18 Grounding Outside of the Sealed Section–Self-Contained Meter ....	-
Figure -19 Grounding Outside of the Sealed Section Transformer-ated Meter .....	-
Figure -20 Temporary-Service Metering Pedestal .....	- 0
Figure -21 Plug-In Temporary Service .....	- 1
Figure -22 Typical Plug-In Adapter .....	- 1
Figure -2 Transfer Switch .....	-
Figure -2 S D Manual Transfer Switch .....	- 6

Contents	Page
<b>Section – Electric Metering Residential</b>	
Figure 6-1	Typical Underground Service-Termination Enclosure, Combination Meter-Socket Panel ( Residential, 0 Amps–22 Amps) . . . . . 6-
Figure 6-2	Typical Service-Termination Enclosure, Combination Meter-Socket Panel for a Class 20 Meter ( Residential, 120/2 0-olt, 226-Amp Through 20-Amp Service) . . . . . 6-6
Figure 6-	Underground Combination Meter and Current-Transformer Cabinet (201 Amps– 00 Amps, 1Ø or Ø) . . . . . 6-
Figure 6-	Typical Underground, Separate-Bused, Current-Transformer Cabinet and Safety-Socket Meter Box Assembly (201 Amps– 00 Amps, Ø and 201 Amps–600 Amps, 1Ø) . . . . . 6-8
Figure 6-	Combination Meter Socket Load Center . . . . . 6-9
Figure 6-6	Typical Combination Meter and Service Termination Panel for a Class 20 Meter ( Residential, 120/2 0-olt, 226-Amp Through 20-Amp Service) . . . . . 6-10
Figure 6-	Overhead-Fed Combination Meter and Current-Transformer Cabinet (201 Amps– 00 Amps, 1Ø or Ø) . . . . . 6-11
Figure 6-8	Overhead-Fed, Separate-Bused, Current-Transformer Cabinet and Meter Box (201 Amps– 00 Amps, 1Ø or Ø) . . . . . 6-12
Figure 6-9	Overhead- or Underground-Fed Combination Meter and Service-Termination Panel (100 Amps–22 Amps, 1Ø) . . . . . 6-1
Figure 6-10	Overhead or Underground Service-Termination Meter Panel with Manual Bypass studs ( 20 Amps, 120/2 0-olt, 1Ø) . . . . . 6-1
Figure 6-11	Overhead Service, Grouped-Meter Installation Without a Main Switch ( 00 Amps Max, 1Ø or Ø) . . . . . 6-16
Figure 6-12	Underground Service, Grouped-Meter Installation Without a Main Switch . . . . . 6-16
Figure 6-1	Typical, Manufactured, Combination, Multimeter Installation: Seven Meters or More . . . . . 6-1
Figure 6-1	Clearances for a Typical, Manufactured, Combination, Multimeter Installation . . . . . 6-18
Figure 6-1	Horizontal Meter Trough Installation: Six Meters or Less . . . . . 6-20
Figure 6-16	Vertical Meter Trough Installation: Five Meters or Less . . . . . 6-20

Contents	Page
<b>Section – Electric Metering Nonresidential, Industrial, and Agricultural</b>	
Figure -1	Bused, Safety-Socket Meter Box for Self-Contained Metering (0 Amps–100 Amps) . . . . . -
Figure -2	Bused, Safety-Socket Meter Box for Self-Contained Metering (101 Amps–200 Amps) . . . . . -
Figure -	Underground Combination Meter and Current-Transformer Cabinet (201 Amps– 00 Amps, 1Ø or Ø) . . . . . -
Figure -	Separate-Bused Current-Transformer Cabinet and Meter Box with Underground Service-Termination Pull Box (201 Amps– 00 Amps, Ø and 201 Amps–600 Amps, 1Ø) . . . . . -8
Figure -	Underground Service Combination Meter and Current-Transformer Cabinet (600 Amps, 1 or , 800 Amps ) . . . . . -10
Figure -6	Switchboard Pull Section . . . . . -11
Figure -	Separate Pull Box . . . . . -11
Figure -8	Bottom-Fed Service Section . . . . . -11
Figure -9	Overhead-Fed Combination Meter and Current-Transformer Cabinet (201 Amps– 00 Amps, 1Ø or Ø) . . . . . -1
Figure -10	Overhead-Fed, Separate-Bused, Current-Transformer Cabinet and Safety-Socket Meter Box (201 Amps– 00 Amps, 1Ø or Ø) . . . . . -1
Figure -11	Overhead, Service-Termination, Standard Switchboard Service Section (0 olts–600 olts) . . . . . -1
Figure -12	Overhead Service, Grouped-Meter Installation without a Main Switch (Max. 00 Amps, 1Ø or Ø) . . . . . -1
Figure -1	Underground Service, Grouped-Meter Installation without a Main Switch (Max. 00 Amps, Ø, or 600 Amps, 1Ø) . . . . . -1
Figure -1	Grouped-Meter Installation with a Main Switch (Max. 00 Amps, Ø, 600 Amps, 1Ø) . . . . . -1
<b>Section – Electric Metering Pedestals</b>	
Figure 8-1	Residential Electric Metering Pedestal . . . . . 8-2
Figure 8-2	Front view . . . . . 8-
Figure 8-	Side view . . . . . 8-
Figure 8-	Service Cable Termination Section . . . . . 8-

## List of Figures

Contents	Page
<b>Section – Electric Metering Pedestals</b>	
Figure 8-1	Fixed Polycarbonate Metering Window ..... 8-1
Figure 8-6	Service Cable Termination Section Top View ..... 8-6
Figure 8-7	Directional Views ..... 8-6
Figure 8-8	Service Cable Termination Section Top View ..... 8-8
Figure 8-9	Front Outside ..... 8-9
Figure 8-10	Front Inside ..... 8-8
Figure 8-11	PG&E Service Cable Termination (Pull) Section ..... 8-8
Figure 8-12	Side View: Cover Removed ..... 8-9
Figure 8-13	Front View–Interior Cover Removed ..... 8-9
Figure 8-14	Nonresidential CT Pedestal (00 600 Amps 1Ø or Ø, 800 Amps Ø) ..... 8-1
Figure 8-15	Nonresidential CT Pedestal Side Mount Meter Panel (00 600 Amps 1Ø or Ø, 800 Amps Ø) ..... 8-1
<b>Section – Electric Metering Components and Cable Terminating Facilities</b>	
Figure 9-1	Test Blocks for Self-Contained Metering, 0 Amps–22 Amps ..... 9-2
Figure 9-2	Removable Test Switch Mounting-Base Detail ..... 9-2
Figure 9-3	Cabinet Showing Stud-Mounted Cover ..... 9-3
Figure 9-4	Cabinet Showing Flanged Cover Fastened by Sealable Rivet atches ..... 9-3
Figure 9-5	Cabinet Showing Ringed Front Cover ..... 9-3
Figure 9-6	Wire, Single-Phase Service, Mounting Base ..... 9-3
Figure 9-7	Wire, Three-Phase Service, Mounting Base ..... 9-3
Figure 9-8	CT Mounting Base (Single-Phase, Wire, 00 Amps 600 Amps, 0 volts–600 volts) ..... 9-6
Figure 9-9	CT Mounting Base (Three Phase, Wire, 00 Amps 800 Amps, 0 volts 600 volts) ..... 9-3
Figure 9-10	Bused CT Cabinet, Wire Service, 00 Amps–600 Amps ..... 9-8
Figure 9-11	Bused CT Cabinet (Wire Service, 00 Amps Max) ..... 9-9

Contents	Page
<b>Section 9 – Electric Metering Components and Available Terminating Facilities (continued)</b>	
Figure 9-12	Meter Box for Transformer-Related Metering (Single-Phase or Three-Phase Installations) . . . . . 9-10
Figure 9-1	Remote Metering Cabinet (Three-Phase Installations) . . . . . 9-11
Figure 9-1	Typical Underground Service Termination Section and Pull Box, Wall-Mounted or Pad-Mounted (Floor-Standing) . . . . . 9-1
Figure 9-1	Detail of Clearance Requirements for Adjacent Termination Bus Stubs . . . . . 9-1
Figure 9-16	Detail of Aluminum, Termination Bus Stubs . . . . . 9-16
Figure 9-1	Service-Terminal Conductor Connector . . . . . 9-1
<b>Section 10 – Electric Switchboards 0 Volts Through 600 Volts</b>	
Figure 10-1	Switchboard Wall Opening Between Sections . . . . . 10-6
Figure 10-2	Standard Switchboard, CT Compartment, 0 Amps–600 Amps, Single-Phase . . . . . 10-8
Figure 10-	Standard Switchboard, CT Compartment, 0 1,000 Amps and 1,001 1,200 Amps, Three Phase . . . . . 10-10
Figure 10-	Bus Drilling Detail . . . . . 10-11
Figure 10-	Standard Switchboard, CT Compartment, 1,001 Amps– 3,000 Amps, Single-Phase or Three-Phase, - Wire Service . . . . . 10-12
Figure 10-6	Standard Switchboard, CT Compartment, 1,001 Amps– 3,000 Amps, Three-Phase, - Wire Service . . . . . 10-1
Figure 10-	Standard Switchboard, CT Compartment, 3,001 Amps and Larger, Three-Phase, - Wire Service . . . . . 10-16
Figure 10-8	Standard Switchboard, CT Compartment, 3,001 Amps and Larger, Three-Phase, - Wire or - Wire Service . . . . . 10-18
Figure 10-9	Switchboards, 0 Volts–600 Volts, CT Compartment, 1,001 Amps– 3,000 Amps, Removable Link and CT Support (One-Bolt Configuration) . . . . . 10-20
Figure 10-10	Switchboards, 0 Volts–600 Volts, CT Compartment, 1,001 Amps– 3,000 Amps, Removable Link and CT Support (Four-Bolt Configuration) . . . . . 10-21



## List of Figures

Contents	Page
<b>Section 0 – Electric Switchboards 0 olts Through 00 olts, continued</b>	
Figure 10-11 Switchboards, 0 olts–600 olts, CT Compartment, 1,001 Amps and larger, removable link and CT Support (Two-Bolt Configuration) . . . . .	10-22
Figure 10-12 Switchboards, 0 olts–600 olts, CT Compartment, 1,001 Amps and larger, removable link and CT Support (Six-Bolt Configuration) . . . . .	10-2
Figure 10-1 Standard Section for Self-Contained Meter Sockets, 0 Amps–22 Amps, Installed in Switchboards: nonresidential . . . .	10-2
Figure 10-1 Pull Section . . . . .	10-2
Figure 10-1 Separate Pull Box . . . . .	10-2
Figure 10-16 Bottom-Fed Service Section . . . . .	10-2
Figure 10-1 Switchboard Pull Section High Entry . . . . .	10- 0
Figure 10-18 Switchboard Pull Section Low Entry . . . . .	10- 0
Figure 10-19 Extended Top on Switchboard Pull Section Front View (Side Entry) or Side View (Back Entry) . . . . .	10- 1
Figure 10-20 Additional Side or Back Switchboard Pull Section High Entry . . . .	10- 2
Figure 10-21 Additional Side or Back Switchboard Pull Section Low Entry . . . .	10-
Figure 10-22 Arranging Conduit in the Termination or Additional Pull Section (Example of a Front View, High Back Entry) . . . . .	10-
Figure 10-2 Banding Terminal Detail . . . . .	10-
Figure 10-2 Spacing Requirements . . . . .	10-
Figure 10-2 Buses Accessible From Only One Side (Bolts Must Be Secured in Place) . . . . .	10-
Figure 10-26 Buses Accessible From Either Side (Mounting Surfaces on Both Sides of Bus) . . . . .	10-
Figure 10-2 Standard Switchboard Service Section with CT Compartment and Filler Panel, 0 olts–600 olts . . . . .	10- 0
Figure 10-28 Low-Profile Switchboard Service Section, with CT Compartment, for Underground Service . . . . .	10- 1
Figure 10-29 Standard Switchboard Service Section, 1 -Inch Ringed Panel for Socket Meter and Test Switch . . . . .	10- 2

---

<b>Contents</b>	<b>Page</b>
-----------------	-------------

---

**Section 0 – Electric Switchboards 0 olts Through 00 olts, continued**

Figure 10- 0 Standard Switchboard Service Section, 0-Inch Panel for Socket Meters and Test Switches .....	10-
Figure10- 1 Outdoor or ain-Tight Enclosures for Switchboards .....	10-
Figure10- 2 Outdoor or ain-Tight Enclosures for Switchboards .....	10-
Figure10- Outdoor or ain-Tight Enclosures for Switchboards .....	10-
Figure 10- Outdoor or ain-Tight Enclosures for Switchboards .....	10-
Figure 10- Existing Switchboard .....	10-

**Section Electric Switchboards 0 olts Through 2 ,000 olts, and Primary Services**

Figure 11-1 Primary Switchgear Termination Section Pad Detail .....	11-6
Figure 11-2 inged Meter Panel with Multiple Sockets for 2, 00- to 2 ,000- Service .....	11-8
Figure 11- inged Meter Panel with Dual Socket for 2, 00- Through 2 ,000- Service .....	11-9
Figure 11- Typical, igh- oltage Metering Enclosure: 2, 00- Through 1 ,000- Service .....	11-12
Figure 11- Typical, igh- oltage Metering Enclosure: 1 ,001- Through 2 ,000- Service .....	11-1
Figure 11-6 Typical, igh- oltage Metering Enclosure, 1 ,001- Through 2 ,000- Service .....	11-1
Figure 11- Additional Side or Back Switchgear Pull Section igh Energy ...	11-16

cited in Cal. Rest. Ass'n v. City of Berkeley, No. 21-16278 am archived December 27, 2023

This Page Intentionally Left Blank

*cited in Cal. Rest. Ass'n v. City of Berkeley  
No. 21-16278am archived December 27, 2023*

# SECTION 1 GENER

*cited in Cal. Rest. Ass'n v. City of Berkeley  
No. 21-16278am archived December 27, 2023*

SECTION 1 GENER

SECTION 1 GENER

*cited in Cal. Rest. Ass'n v. City of Berkeley  
No. 21-16278am archived December 27, 2023*



Know what's below.  
Call before you dig.

Section 1  
General

Safety Alert

Contacting overhead or underground electric lines or equipment and natural gas pipelines can cause serious injury or death. Any part of a crane, scaffold, construction material, antenna, cable, rope, guy wire, or tool that touches an overhead electric line or penetrates an underground cable can become energized. Penetrating an underground natural gas line with a backhoe or other tool can cause a violent explosion.



**WARNING**

To avoid potential accidents, do **not** begin to excavate before identifying underground facilities

State law requires applicants to contact [Underground Service Alert \(USA\)](#) by dialing [811](#) at least 2 working days before excavation (weekends and holidays excluded). Ensure that you call [USA](#) when planning underground work, before digging begins, to allow adequate time for [USA](#) to determine the location of underground gas and electric lines or equipment. *The potential for an accident exists if applicants fail to request USA to identify underground utility facilities before excavation begins.*

First, the applicant must mark the excavation area with white paint. Then, [USA](#) arranges for participating companies to mark the locations of their underground facilities at the jobsite. This is a free service. See the [USA](#) color-code identifiers below and on the back of this manual.

Additional information is available at [www.pge.com/digsafely](http://www.pge.com/digsafely). Also, see [USA](#) services at the [USA North](#) website at <http://www.usanorth.org>. [USA](#) is a locating service for excavation only. Do not use [USA](#) for design purposes.



S



Dig Safely

Table 1-1 USA Color Coding<sup>1</sup>

Excavation Sites & Underground Facilities	Marking Color
Proposed location	White
Electric lines	Pink
Gas	Yellow
Water	Blue
Communication	Orange
Other	Green
Unidentified	Purple
Empty	Black

California State Office

rc-Flash a ard arning

All applicants or persons authorized by PG&E who are working on, working near, or observing others working on any PG&E equipment, enclosures, or other facility potentially are e posed to arc-flash hazards and are required to wear flame-resistant (F ) clothing. The requirement to wear F clothing applies to everyone. Applicants and their personnel must wear F clothing before being allowed access to perform work in and around PG&E facilities. Also, applicants and their personnel must ensure that they wear the appropriate level of F clothing for the job being performed. The tags on all F garments must clearly identify them as flame resistant and clearly indicate the arc rating hazard risk category ( C). All garments must have a minimum rating of C 2.

See [Appendix A, “Acronyms and Glossary.”](#) for a definition of facilities.

1 1 Purpose

NOTE: For the purpose of this manual, the word “applicant” is used generically to refer to the Pacific Gas and Electric Company (PG&E) customer, or to the person or persons representing the PG&E customer in the application/construction process, including a contractor, design consultant, or installer. The word “customer” is used only when the word “applicant” is not applicable. Also, PG&E is sometimes referred to as the “Company” throughout this manual.

This manual is designed to help applicants establish gas and electric service. By reading the mandates published in this manual, applicants will understand not only the steps required to apply for service, but also the legal and safety requirements driving those steps. PG&E provides this manual to all gas and electric applicants in an effort to ensure that the Company can continue to deliver safe, uniform service.

The 2022-2023 *Greenbook* supersedes all previous editions and revisions. This manual is a collection of requirements and policies for establishing electric and gas service to new or remodeled installations. The *Greenbook* typically is updated at least annually however, PG&E’s building requirements, as well as gas and electric design standards, are subject to change throughout the year. It is important that all applicants consult the online version of the *Greenbook* before finalizing project plans.

In addition to the requirements provided in this manual, applicants for gas or electric service also must comply with federal regulations and with all applicable [tariffs](#), as well as the rules and general orders set forth by the California Public utilities Commission (CP C).

## 1.1. (continued)

These regulations and orders include, but are not limited to, the following documents:

- [General Order \(G.O.\) 95, “Rules for Overhead Electric Line Construction”](#)
- [G.O. 112-F, “Rules Governing Design, Construction, Testing, Operation, and Maintenance of Gas Gathering, Transmission, and Distribution Piping Systems”](#)
- [G.O. 128, “Rules for Construction of Underground Electric Supply and Communication Systems”](#)
- [Code of Federal Regulations \(CFR\), Title 9, “Transportation,” Part 192, “Transportation of Natural and Other Gas by Pipeline: Minimum Federal Safety Standards”](#)

Finally, applicants must comply with all other federal, state, and local regulations. These regulations may include a Federal Aviation Administration (FAA) review for structures that impinge on navigable airspace. In such cases, the FAA requires filing notice of proposed construction a minimum of 30 days before starting the proposed construction. The FAA may issue a determination of hazard to air navigation and recommend actions to mitigate or eliminate that hazard. For additional information, please contact your PG&E project coordinator.

## 1.2 Permits and Inspections

Builders who are constructing new buildings or remodeling existing buildings must conform to the following guidance documents.

- A. The current provisions of city and county ordinances.
- B. Rules on file with, or issued by, the CPUC.
- C. Applicable rules and laws of the state of California, including, but not limited to, the following three codes.
  - Plumbing codes
  - Mechanical codes
  - Electric codes

Local and state ordinances require applicants to obtain the appropriate permits and final inspections before PG&E establishes services to any building or structure.

In areas where local ordinances governing gas or electrical installations do not exist, or where inspections provided by local jurisdictions for such installations are not available, the applicant must obtain written confirmation from a qualified person that the facilities meet the requirements specified in this manual.

PG&E will not establish gas or electric service until the gas piping or electric service facilities are installed satisfactorily.

**NOTE:** Gas meter release forms obtained from a permitting agency must include the specific, requested pressure (e.g., 1/2 inches w.c., 2 psig, 10 psig).



## Section 1, General

## 1.2. (continued)

PG&E's inspection process includes service requirements that are not governed by local or state codes. Parts of the applicant's installation may require approval by state, local, and PG&E inspectors.

## 1 2 1 Pre-Construction Meetings

All applicant-installed and shared construction jobs require a pre-construction meeting. Pre-construction meetings provide a time to discuss safety requirements and expectations and to complete a pre-construction meeting checklist.

The pre-construction meeting is intended to:

- Introduce key individuals and exchange contact information.
- Discuss the project timelines.
- Advise personnel about construction obligations and requirements.
- Review construction drawings and gas service records (GS s).
- Discuss warranty obligations.
- Clarify roles and responsibilities.
- Discuss proper PG&E operator qualifications for covered tasks.
- Confirm if there is a Facility at site letter.
- Confirm applicant responsibilities for as-built documentation.

The PG&E job owner is responsible for scheduling and facilitating pre-construction meetings and for ensuring that [Form TD- 62M-F01, "Pre-Construction Meeting Checklist,"](#) is completed. Participants in formal pre-construction meetings must include:

- Applicant and the applicant's representative
- Applicant's contractor
- PG&E's senior new business representative (S B ), new business representative ( B ), or industrial power engineer (IPE)
- PG&E's gas and electric inspectors
- Representatives from all other joint trench utilities
- Corrosion mechanic, as needed

Responsible PG&E employees and contract personnel must follow Company qualifications, operator qualifications (O s), standards, and procedures related to job-specific inspections.

## 1 Applying for Building and Renovation Services



Residential

An [Application for service process](#) online form is required for all new gas or electric services, as well as for relocating or rearranging existing services.

Whether you are building or renovating your home, expanding your business facility, or opening a facility at a new location, you can apply on the Internet at “[Customer Connections Online](#)” ([www.pge.com/customerconnections](http://www.pge.com/customerconnections)) and track your project with our new online tools.

Also, at the PG&E Internet websites below, you will find guides for getting started, process overviews, project cost ranges, online applications, and more. This information is provided to help you plan your project and get started. For more information, visit the following web pages.

- [Residential](#)
- [Small & Medium Business](#)
- [Large Business](#)



Nonresidential

Applicants without Internet access may contact the Building and Renovation Service Center 1-800-392-82. PG&E representatives will provide you with details about the process and assist you with applying for service.

The process for installing or changing gas and electric services takes time and planning. PG&E recommends you contact us early in the process with accurate load information and the date that the services are required to allow for adequate time to complete your service request.

Large-capacity gas meters, electric transformers, or other special equipment often require several months lead time to ensure a timely delivery from the manufacturer.

Applicants must contact their local PG&E project coordinators when approved construction plans change, or when situations that affect PG&E’s service arrangements occur during construction, so that mutually satisfactory, alternate arrangements can be made.

To assist PG&E in its goal to deliver safe, uniform service, applicants should use the following guidelines when transmitting electronic drawing files for architectural, mechanical, and civil site plans.

1. PG&E’s electronic drawing tool is AutoCAD, .DWG format. Ensure that submitted electronic drawings are either readable using, or compatible with, AutoCAD.
2. Applicants can upload documents at PG&E’s “[Customer Connections Online](#)” ([www.pge.com/customerconnections](http://www.pge.com/customerconnections)) Internet website. Drawings also may be sent as an email-attached file.
- Applicants who do not use the online option described in number 2. above should send drawings for large projects in a zipped format.
- Use layering, if possible, and preserve the layering when transferring files to PG&E.

Customer  
Connect

## 1. . (continued)

- . Save all drawings in model space instead of paper space.
- 6. Make drawing plans two dimensional, with the “ ” elevation at zero.
  - . Ensure that any External Reference Files (ref) or drawing updates maintain a consistent insertion point.
- 8. Include all related drawing files (e.g., elevations, landscape plans, other proposed underground facilities).

Please contact your local PG&E project coordinator if you have any questions.

PG&E is committed to complying with all federal, state, and local environmental laws, regulations, and rules. Applicants must provide PG&E with copies of permits showing that they have met all environmental compliance requirements when submitting applications for service. See the “[Applicant Responsibilities for Environmental Reviews for Service Requests](#)” letter for more information. Applicants can obtain copies of this letter from their local PG&E project coordinators.

Project permits or approvals may contain conditions that require or restrict certain service designs or construction activities by PG&E, applicants, agents, consultants, or contractors. The applicant must bring these conditions to PG&E’s attention to ensure that the requirements or restrictions are included in the project design during the planning and construction phases. When submitting the service application, the applicant must provide PG&E with a written copy of any special conditions, identifying the requirements or restrictions that affect the project design and/or PG&E installation activities.

## 1 Changes in Requirements

PG&E may revise its design and construction documents relating to applicant service requirements between updates to this manual. Except when required by law, PG&E will apply only those construction and design specifications, standards, terms, and conditions that are applicable to a new extension of service project for the 18 months following the date the application for a new extension of service project is approved. The approval date of a new extension of service application refers to the earlier of either the effective date of the contract for the extension of gas and/or electric service or the date when PG&E first invoices the customer for the extension of gas and/or electric service.

These requirements apply as long as applicants complete approved projects within 18 months. If the applicant has not initiated construction within 18 months of PG&E’s initial approval, PG&E may review the design and, if warranted, refresh the cost estimate.

If the applicant does not fulfill obligations under the extension agreement, PG&E may, at its discretion, cancel the agreement (see Provisions Form 62-0982, Section 20). PG&E can then request another review of the design before approving construction activities.

Also, for applicant design jobs, refer to the [Understanding applicant design and installation responsibilities](#) website. On applicant design jobs, the version of the design and construction document that is in effect on the date PG&E approves and signs-off on the final Globals package determines the requirements that the design must meet. The Globals package is valid for 90 days.

## 1. . (continued)

When building projects are divided into separate phases (or tracts) where some of the construction phases will not be completed for more than 18 months from the date the project is approved, PG&E will initiate a review of the design and apply current PG&E construction and design specifications, standards, forms, and conditions that are applicable to the remaining phases of the project.

Applicants are encouraged to contact PG&E early in the planning stages of their projects. By consulting with their local project coordinators, applicants are made aware of the current construction requirements before they initiate any design work.

Do not perform construction using an unauthorized or preliminary drawing. The applicant assumes full responsibility for errors, omissions, or changes if the project is constructed using either preliminary drawings or drawings that are not approved by PG&E.

PG&E will not accept or assume ownership of facilities installed by the applicant before the construction design is completed and approved by PG&E. Additional facilities, even if provided at no cost to PG&E, represent increased plant in the rate base. This includes associated, long-term increases in taxes and maintenance expenses.

Applicants are responsible for any additional design changes or reconstruction costs that may be required if PG&E does not accept unapproved facilities. PG&E will not energize or pressurize a system that has not received final design approval and passed all inspections.

Engineering and construction documents or requirements are incorporated into new editions of this manual; however, revisions are made periodically. Applicants can obtain revised engineering documents or requirements in two ways:

- Find these documents on PG&E's Internet site ([www.pge.com/greenbook](http://www.pge.com/greenbook)).
- These documents are available through your local PG&E project coordinators.

Some of the information contained in this manual is based on government codes and ordinances that are subject to change as determined by the governmental authorities. PG&E does not assume responsibility for keeping information in this manual current with these government codes, ordinances, or other requirements. Applicants should consult the responsible governmental agency with questions about the applicability of any construction procedures or requirements.

## 1. Additional Nonresidential (Commercial and Industrial) Service Information

For electric installations of more than 600 volts ( ), refer to [Section 11, "Electric Switchboards: 601 olts Through 2 ,000 olts, and Primary Services."](#) Generally, this manual does not include information about large nonresidential (i.e., commercial or industrial) gas loads; however, PG&E provides applicants with individual job-design specifications after they request service.

1 Design and Construction

1 1 PG&E s Responsibilities

PG&E is responsible for planning, designing, and engineering its service facilities and service laterals using Company standards for design, materials, and construction.

1 2 Applicant s Responsibilities

Residential and nonresidential applicants for gas and/or electric extensions and services may select a contractor to design their facilities.

PG&E requires a clear path from existing distribution facilities to the location on the applicant’s jobsite where the services will be connected. Depending on the project, the applicant may need permits or approvals for these supply lines in order to comply with federal, state, and local requirements, regulations, and rules (including environmental laws).

Local PG&E project coordinators can provide applicants with information about available options for clearing supply lines, as well as any associated design and contract requirements for their projects.

Before designing their projects, applicants and/or their contractors must complete PG&E’s [Application for service process](#) online form, provide applicable construction plans, and submit any required project deposits to PG&E.

1 Providing Access to PG&E Electric Facilities

Applicants are required to provide access roads on their properties to PG&E pad-mounted or subsurface (i.e., transformer or switch) facilities. The roads must be accessible to PG&E at all times and constructed with either a Class 2 or an AB road base that is a minimum of 10 feet wide, with 18 feet of vertical clearance above. Also, there must be a 10-foot radial, hammerhead-style turn-around area at the end of the roads.

Do not place equipment more than 1 feet away from the edge of the road to facilitate the placement of the equipment using lifting equipment. Failure to design for and construct based on this guidance may result in the requirement that the applicant sign a Rule 16 Special Facilities Lifting Agreement whereby, during construction, maintenance, and operations, the applicant will be responsible for fees associated with PG&E’s specialized lifting contractors and equipment.

Avoid placing equipment immediately below, or in the vicinity of, overhead transmission, distribution, secondary voltage supply, and communication lines, when possible.

This guidance promotes the safe operation of the electric grid. By limiting equipment installation below energized lines, the chance that specialized lifting equipment contact an overhead energized line is minimized. Additionally, if safe working clearances cannot be maintained when working with specialized lifting equipment, restoration efforts could be delayed and necessitate an emergency shutdown, or require the temporary removal of the lines, to complete work safely.

## 1.6. . (continued)

In cases where locations exist where equipment can be placed to minimize the possibility of exposure to live lines, these locations must be used. PG&E and the applicant must work together to identify a mutually agreeable location for installing the equipment safely. Only after all local relocation efforts have been exhausted and local service planning agrees that this installation could be safely considered, should the proposed installation be submitted to the Distribution Standards department for the consideration of variance. When a location cannot be agreed to that meets with the intent of this guidance, PG&E has the final decision on placement of the equipment.

Refer to [umbered Document 0 1122, "Clearances and ocation equirements for Enclosures, Pads, and nderground Equipment,"](#) for additional requirements. When in doubt, contact your local PG&E Electric Construction supervisor for guidance before approval of a design.

## 1 Installing Transformers

PG&E will specify the type of transformer installations to be constructed on applicants' premises.

Applicants may contact their local PG&E project coordinators to obtain specific transformer requirements for their projects.

PG&E's standard transformer installations for residential, commercial, and industrial services, excluding agricultural areas, are described in Item A. and Item B. below:

- A. A pole-bolted transformer in overhead areas when the applicant's load does not require a kilovolt ampere (k A) or greater transformer.
- B. A pad-mounted transformer in underground areas or in an area with overhead facilities when PG&E determines that the applicant's load requires a k A or greater transformer.

As described in [Electric Rule 15, "Distribution ine Extensions,"](#) and [Electric Rule 16, "Service Extensions,"](#) found online at <https://www.pge.com/tariffs/index.page>., requests for the installation of a subsurface transformer are not allowed when it is technically feasible to install a pad-mounted transformer.

PG&E's standard transformer installations for agricultural services are described in item C. below:

- C. A pole-bolted transformer in overhead areas when the applicant's load does not exceed the capability of PG&E's largest available kilovolt ampere (k A) overhead transformers for the voltage and phase being served.

If required or requested, the installation of a pad-mounted transformer is also allowed.

Also see Subsection 1.1 ., "Standard Service oltage and oad imitations," on Page 1-2 .

## 1.6. . (continued)

Applicants must provide space on their premises at locations approved by PG&E for standard transformer installations *if* PG&E determines that the load to be served requires a separate transformer installation to serve only the applicant.

**NOTE** or reasons of safety and reliability, PG&E does not allow applicants to install water sprinklers to cool off transformers.

## 1 Underground Electric Service E tensions

Applicants must ensure that an underground service is installed, where required, to comply with applicable tariff schedules, laws, ordinances, or similar requirements of governmental authorities having jurisdiction, and may be necessary as determined by PG&E where an applicant's load requires a separate, -k A or greater transformer installation. For more information, see [Electric Rule 16](#).

## 1 7 Connecting and Sealing Services

A. PG&E provides standard service to applicants as described below.

1. Establish service at one service delivery point, through one meter, and at one voltage class or pressure.
  2. Design service to extend from the connection to the distribution facilities along the shortest, most practical, and most available route to the service termination facility or service delivery point, as determined by PG&E.
- PG&E may require a service location to be closer to the distribution facilities in the following instances:
- In areas where the nearest building is a considerable distance (i.e., 200 feet or more) from the property line.
  - If, in PG&E's judgment, there is a potential hazard between the property line and service location.

B. The requirements for standard service are described below.

1. Only authorized PG&E employees can connect or disconnect PG&E's gas or electric service to the building or structure.
  2. Authorized persons must not tamper with or break PG&E seals placed on meters and associated service equipment.
- Only authorized PG&E employees can remove, replace, or interfere with PG&E's meters, seals, connections, padlocks, or other locking devices.
- Applicants must call PG&E if it is necessary either to disconnect the service or remove the meter because of remodeling, alterations, or other activities.

## 1. . (continued)

- . Applicants must not connect house gas pipes or other applicant facilities to the plugged side of the gas service-tee fitting. That fitting is for PG&E's use only.
- 6. Applicants may place gas and electric service and metering equipment in dedicated rooms within buildings when approved by PG&E.
- . Applicants must not locate service termination enclosures in the interior, inhabitable area of residences.
- 8. Applicants must ensure that all service and metering facilities are readily accessible.
- 9. PG&E must review and approve of all service and meter locations and arrangements before installing any metering facilities, service-termination enclosures, or other utility service facilities.
- 10. The applicant assumes the risk for any work performed without requesting PG&E's advanced approval. PG&E can charge the applicant if it is necessary to make changes to unapproved work.
- 11. An unauthorized connection to PG&E's gas or electric facilities, or to facilities used to provide utility services, may be a violation of the [California Penal Code, Part 1, "Crimes and Punishments," Title 1, "Crimes Against Property," Chapter 1, "Arson," Part 98, and Chapter 1, "Malicious Injuries to Railroad Bridges, Highways, Bridges, and Telegraphs," Part 9. c. Violators could be subject to damages pursuant to California Civil Code, Division 1, "Obligations," Part 1, "Obligations Arising From Pecuniary Transactions," Title 1, "Utility Services," Section 1882, et. Sequitur.](#) These sections address connecting to utility meters and facilities and diverting utility services. They specifically prohibit any person from tampering with, making, or causing to be made any connection or reconnection with property owned or used by the utility to provide utility service, without the utility's authorization or consent.
- 12. Applicants or their contractors must not paint, color, or discolor the gas and electric facilities, including the meters.

## 1 access to an applicant's Residence, Building, or Property

PG&E has the right to access company facilities located on an applicant's premises at any time, for any purpose connected with furnishing gas and or electric service. These purposes include, but not limited to, the following activities:

- Reading meters.
- Inspecting utility facilities.
- Making routine repairs.
- Performing maintenance and emergency work.
- Exercising any and all rights secured to PG&E either by law or under PG&E's tariff schedules, including [Electric Rule 16, "Service Extensions,"](#) and [Gas Rule 16, "Gas Service Extensions."](#)



Section 1, General

1 Overhead Electric Lines

The California Division of Occupational Safety and Health (Cal/OSHA), Title 8, Division 1, "Department of Industrial Relations," Chapter 1, "Division of Industrial Safety," Subchapter 1, "Construction Safety Orders," Article 1, "Cranes and Derricks in Construction," Section 1612, "Power Line Safety," and the associated sub-articles, require that minimum safe working and traveling distances be maintained from cranes and derricks to overhead electric lines.

In support of these regulations, PG&E provides the voltage for overhead lines within two business days of receiving a customer inquiry. Call the PG&E Building and Renovation Service Center (BRSC) at 8 - - 82 or Customer Service at 1-800- - 000.

Cal/OSHA, Title 8, Chapter 1, Subchapter 1, "Electrical Safety Orders," Group 2, "High-voltage Electrical Safety Orders," Article 1, "Provisions for Preventing Accidents Due to Proximity to Overhead Lines (Formerly Article 86), Section 29.6, "Provisions for Preventing Accidents Due to Proximity to Overhead Lines," requires that minimum safe working distances be maintained from overhead electric lines. Specific requirements taken from the regulation are shown in Table 1-2, "Minimum Safe Working Distances (Scaffolds, Equipment, Tools, Structures, and People)," and Table 1-3, "Minimum Safe Working Distances (Boom-Type Lifting or Hoisting Equipment)," both on Page 1-12.

Table 1-2 Minimum Safe Working Distances (Scaffolds, Equipment, Tools, Structures, and People)

Nominal Voltage (Phase-to-Phase)	Minimum Required Clearance (Feet)
0 e	
0 e	
0 e	

*cited in Cal. Rest. Ass'n v. City of Berkeley No. 21-16278am archived December 27, 2023*

## 1.9. (continued)

Table 1- Minimum Safe Working Distances (boom-Type Lifting or Hoisting Equipment)

Nominal Voltage (Phase-to-Phase)	Minimum Required Clearance (Feet)
0 e	
0 e	
0 e	
0 e	
0 e	
0 e	
0 e	
0 e	

Contact a local PG&E project coordinator with any questions about working near overhead electric lines or about nominal voltage.

## 1 10 Underground Electric Lines and Gas Pipelines

As mentioned on Page 1-1, state law requires applicants to contact SA by dialing 811 at least 2 working days before excavation (weekends and holidays excluded). Applicants must call SA when *planning* underground work (before *digging* begins) to allow adequate time for SA to determine the locations of underground transmission and distribution gas and electric lines and/or equipment.

SA arranges for participating companies to mark the locations of their underground facilities at the jobsite. There is no charge for this service. The applicant must mark each end of the excavation area with white paint as well as the total length in feet. Applicants should also use arrows to indicate the direction of the trench. For more information, go to [www.pge.com/digsafely](http://www.pge.com/digsafely). Also, learn more about SA services at the SA *orth* website (<http://www.usanorth.org>).



s

## 1 10 1 Safe Landscaping Near Underground Facilities

When any new vegetation are planted, ensure that a minimum of    feet is maintained from underground transmission and distribution gas lines as well as distribution electric lines. Please refer to PG&E's [Guide to Safe Landscaping Near Gas Pipelines](#) and the [Guide to Safe Landscaping Near Underground Electric Lines](#) (located in [Appendix B, "Electric Gas and Service Documents,"](#) located on Page B- ) for helpful information about the types of trees and plants that are safe for areas near transmission and gas pipelines.



Dig Safely

## 1 11 PG&amp;E Safety Training Resources

PG&E wants to ensure that contractors and construction workers avoid electric and natural gas hazards by practicing basic safety rules. Please visit [www.pge.com/contractorsafety](http://www.pge.com/contractorsafety), "[Contractor Safety Program Contract Requirements](#)," for materials to assist you in providing your employees with safety training.

1 12 SmartMeter™ Program

PG&E’s SmartMeter Program is part of a statewide effort driven by the CP C to upgrade California’s energy infrastructure with automated metering technology. The SmartMeter Advanced Meter reading system includes a programmable, solid-state electric meter and a gas module, installed on a traditional gas meter at each service delivery point to measure and record energy use.

For more information on SmartMeters, including instructions on tracking your energy use online or information on the opt-out program, please visit [Understanding your energy use with SmartMeter \(www.pge.com/smartmeter\)](http://www.pge.com/smartmeter)



SmartMeter™

1 1 PG&E Online (Website)

The PG&E website at [www.pge.com](http://www.pge.com) has many tools for building or renovating homes, expanding or renovating business facilities, or opening new locations.

The [PG&E Building and Renovation Services guides](#) are available for residential services at [www.pge.com/building/](http://www.pge.com/building/) and include the following information:

- [Visit our Application for service process](#)
- [Choose a guide](#)
- [Manage your project at Customer Connections Online](#)
- [Excess flow valves](#)
- [Get estimates](#)
- [Pay your project charges online](#)

These tools can help you plan your project and get started. For more information, visit the following web pages.

- Apply online and track your project at [Customer Connections Online \(www.pge.com/customerconnections\)](http://www.pge.com/customerconnections)
- Residential services at [Discover building and renovation services for homeowners \(www.pge.com/building/\)](http://www.pge.com/building/)
- Business and agricultural services at [Discover building and renovation services for businesses \(www.pge.com/newconstruction\)](http://www.pge.com/newconstruction)



Customer Connect

1 1 1 **Electric and Gas Service Requirements** Manual (aka **Greenbook**)

The *Greenbook* is available on the Internet at [www.pge.com/greenbook](http://www.pge.com/greenbook).

**NOTE** Communicate and coordinate all gas and electric service arrangements through your assigned PG&E project coordinator. As mentioned earlier in this section, PG&E documents may be updated independently of this manual however, the project coordinators provide applicants with the latest updated or revised information on request. Applicants must contact their assigned project coordinators to ensure that they are correctly interpreting and using the information found in this manual and in other governing documents.

## 1 1 2 Rates and Tariffs

ate and tariff information is available on the website [“Electricity rates: Choose the plan that works best for you.”](http://www.pge.com/about/rates/) at <http://www.pge.com/about/rates/>. This information also is available on the [PG&E homepage](http://www.pge.com/) (<http://www.pge.com/>) under the rate Plans drop down. Also, the online [“Tariffs”](#) provide current gas and electric rate schedules, preliminary statements, rules, forms, advice letters, and more.

## 1 1 Determining the Electric Service Rating

**A. PG&E Service Rating** The rating of the PG&E service to be supplied is the current rating in amperes of the electrical enclosure where PG&E terminates and connects its supply facilities and conductors. This electrical enclosure or equipment also may be known as the service-termination section, pull can, service section, meter panel, or service-termination enclosure. For overhead services, the service rating is the rating of the electrical enclosure or equipment connected to the weatherhead and mast.

**B. Enclosure Nameplate Labeling and Rating** Electrical enclosures must list on their manufacturers’ main labels (nameplate) a maximum current rating, in amperes, allowed for the equipment. This maximum rating must be written as a numerical value (e.g., 12, 800, 2, 00) and must be acceptable to PG&E. The nameplate label must also describe the voltage, number of phases, and additional electrical information. The nameplate label must be rated for ultraviolet ( ) radiation and exposure of outdoor environments. The label must be easily accessible and permanently attached to the outside front of the equipment enclosure and, when applicable (e.g., switchboard), on each individual section. The label also may be attached to the inside of the enclosure’s outer door.

1. For pad-mounted (i.e., free-standing) enclosures, this information typically is listed on the main nameplate labels as the “Supply” rating. See Figure 1-1, “Nameplate Label Example: Pad-Mounted Electrical Switchboard or Termination Enclosure,” on Page 1-19.

When multiple sections are physically connected together to form a switchboard or switchgear, the supply rating listed on each section, whether bussed or cabled, should typically be the same. A “Section” rating also should be provided as a numerical value on each individual section label. See Figure 10- , “Existing Switchboard,” on Page 10- , as an example of one type of switchboard.

2. For wall-mounted panelboards and termination enclosures, the maximum ampacity rating is for the entire enclosure and must be listed on the main rating label independently from any individual component (e.g., main bus, meter socket, main disconnect) rating. See Figure 1-2, “Label Example: Wall-Mounted Electrical Meter Panel or Termination Enclosure,” on Page 1-19 for an example. The maximum ampacity rating may be titled on the label in any of the following ways.

- Maximum Amps
- Maximum Utility Rating
- Maximum Equipment Rating

## 1.1 . (continued)

- . If a maximum ampacity rating is not included on the electrical enclosure label, PG&E uses the individual component (e.g., main bus, meter socket, main disconnect, current-transformer mounting bracket) with the greatest rating as the service rating.
- . If there are multiple ratings or conflicting ratings either on a single electrical enclosure or on multiple enclosure sections that are physically connected together (i.e., switchboard, switchgear), PG&E uses the greatest rating as the service rating.

- C. **Main Service Disconnect** For installations supplying a single main-disconnecting means (i.e., main breaker or main disconnect switch), or for installations without a single disconnecting means (e.g., a service with no main disconnect and only individual disconnects), the rating of the PG&E service to be supplied is the rating of the electrical enclosure where PG&E terminates and connects its service conductors and not the rating of the main service disconnect.

For switchboards, the PG&E service rating is typically listed as the supply rating. For panelboards, the service rating is the maximum ampacity of the panel if listed on the label. If a maximum ampacity is not listed, then the service rating is the greatest rating for any individual component (e.g., main bus, meter socket) in the panelboard. For more information, see Subsection 1.1 .A., "PG&E Service Rating," on Page 4-1 .

When a main service disconnect (i.e., switch, fuse, or breaker) is installed, the continuous current (i.e., ampere) rating should not exceed the rating of the electrical enclosure or the rating of the section where it is installed. The main service disconnect may have either the same rating or a lower rating than the electrical enclosure.

- D. **Overhead Service to Multiple All Mounted Meter Panels or Meter Boxes** When more than one meter panel or meter box is connected to a separate, sealable gutter or other unrated raceway with power supplied from a PG&E overhead service, the PG&E service rating is the aggregate of all meter panel or meter box ratings.

**EXAMPLE** Three meter panels rated at 200 amps, 100 amps, and 100 amps would have an aggregated rating of 400 amps (200 + 100 + 100).

For illustrations of these types of installations, refer to one of the following two figures:

- [Section 6, "Electric Metering: Residential," Figure 6-11, "Overhead Service, Grouped-Meter Installation Without a Main Switch \( 00 Amps Max, 1Ø or Ø\)."](#) on Page 6-16.
- [Section 7, "Electric Metering: Nonresidential, Industrial, and Agricultural," Figure 7-11, "Overhead Service, Grouped-Meter Installation Without a Main Switch,"](#) on Page 7-1 .

## 1.1 . (continued)

**NOTE** Applicants can use PG&E approved termination enclosures that are manufactured for overhead or underground services and have a maximum ampacity listed on the nameplate labels. The maximum ampacity will be the PG&E service rating. If a termination enclosure is installed, then do not add up the ratings of the meter panels.

**E. Existing Enclosures** If an existing electrical enclosure where PG&E terminated and connected its supply facilities and conductors does not have a visible rating, then the service rating is the maximum rating of the single main-disconnecting means (e.g., main circuit breaker) or of the aggregated maximum ratings of all the service breakers or disconnects if a main-disconnecting means is not present.

**F. Agricultural Services** For agricultural services with a pump motor as the largest load, PG&E recommends that customers install a Variable Frequency Drive (VFD) or similar controller that uses a soft start (SS) system. These types of pump controllers help compensate for in-rush current.

1. For service termination and metering equipment with a main breaker or individual breakers built into the enclosure, refer to the requirements in Subsection 1.1 .C., “Main Service Disconnect,” on Page 1 .
2. For service termination and metering equipment without a main breaker or individual breakers built into the enclosure, PG&E recommends the following types of equipment be installed externally to serve as the main disconnecting means and circuit protection for customer equipment. The following requirements apply.

a. **Class R, Dual Element, Time Delay Fuses** These types of fuses also compensate for in-rush current. When Class R fuses are installed, size them to the pump load but do not exceed the PG&E service rating by more than 12 .

**E A P E** A meter panel rated at 200 amps can have one main service disconnect with Class R fuses rated up to 200 amps (200 1.2 ). A meter panel rated at 400 amps can have one main service disconnect with Class R fuses rated up to 400 amps (400 1.2 ).

b. **Electronic Circuit Breaker** The electronic breaker rating must not exceed the PG&E service rating. The breaker trip settings can be set to compensate for the in-rush current. See [Section 1.1 .C., “Electric Metering: General,” Subsection 1.1 .C., “Electronic Trip Circuit Breakers,”](#) on Page 1 - 2.

**E A P E** A meter panel rated at 600 amps can have one main electronic circuit breaker rated up to 600 amps (600 1.00).

Section 1, General

---

1.1 . (continued)

c. Thermal or magnetic circuit breaker When a standard circuit breaker is installed as the main disconnect and protective device for the customer circuit, the breaker's maximum rating must be 200 or less of PG&E's service termination and metering equipment rating.

E A P E A meter panel rated at 100 amps can have one main thermal or magnetic circuit breaker rated up to 100 amps ( 100 1.2 ).

. When a main disconnect is not installed, and only individual service disconnects are installed on customer equipment, the aggregate total ampacity rating of all the individual service disconnects is allowed to exceed the PG&E service rating by a maximum of 12 .

E A P E A meter panel rated at 100 amps can have multiple individual service disconnects with an aggregated rating up to 100 amps. If there are three disconnects, the individual ratings could be 200 amps, 200 amps, and 100 amps or a combination that is 100 amps or less. If there are five disconnects, the individual ratings could be 100 amps, 100 amps, 100 amps, 100 amps, and 200 amps or a combination that is 100 amps or less.

*cited in Cal. Rest. Ass'n v. City of Berkeley  
No. 21-16278am archived December 27, 2023*

## 1.1 . (continued)

<b>Manufacturer</b>	
<b>Switchboard</b>	
_____	_____
Volts	_____
Phase 3 Wire 4	_____
Frequency	<b>Section No. 1 of 3</b>
_____	<b>Date:</b> _____
<b>Current Ratings—Amperes</b>	
<b>Supply</b> 2000	<b>Neutral</b> 2000
<b>Section</b> 1600	<b>Neutral</b> 2000
_____	_____
_____	_____

cited in Cal. Rest. Ass'n v. City of Berkeley  
No. 21-16278am archived December 27, 2023

Figure 1-1  
Nameplate Rating Label Example: Pad-Mounted  
Electrical Switchboard or Termination Enclosure

<b>Manufacturer Name</b>	
<b>Catalog/Model Number</b>	
Maximum Utility Rating	125
Main Breaker	125
Meter Socket	125
Bus	200

Figure 1-2  
Nameplate Rating Label Example: Wall-Mounted  
Electrical Meter Panel or Termination Enclosure

note in reference to Figure 1-2 on Page 1-19.

- As described in Subsection 1.1 .B.2. on Page 1-1 , use the maximum rating listed on the nameplate label for the whole electric meter panel to determine the PG&E service rating. If a maximum panel rating is not listed, then use the greatest rating for any component (e.g., bus) in the panel.



1 1 Changing an applicant's approved Project or Existing Service loads

An applicant must provide written notice to PG&E of any changes or plans to make material changes either in the amount or in the character of the gas and/or electrical load, equipment, or other facilities installed to supply gas and/or electricity to the applicant's premises, structure, building, or other facilities. For more information, applicants can review [Electric Rule 2](#) and [Gas Rule 2](#), both called "Description of Service," as well as [Electric Rule 3](#) and [Gas Rule 3](#), both called "Application for Service." PG&E requires this written information to determine the following factors.

- The adequacy of the existing utility service and supply facilities.
- The need to modify those facilities to meet and supply the changed load or equipment requirements. This includes changes in the character or nature of the applicant's previously approved gas and/or electric service.

Applicants must notify PG&E of any planned or intended changes in the load, character, or nature of the service required to supply the premises, structure, building, or other facilities.

If an applicant fails to notify PG&E, and the changes exceed the capabilities of the installed utility service, metering, or other equipment and damage those facilities, the applicant is liable for all damages and resultant costs to PG&E.

Applicants must provide PG&E with written notice immediately when they make any material change either in the amount or character of the gas loads and electric amps, appliances, or apparatus installed on the premises to be supplied with gas or electric energy.

*cited in Cal. Rest. Ass'n v. City of Berkeley  
No. 21-16278am archived December 27, 2023*

1 1 **Upgrading, Replacing, and Relocating Electric Facilities, or Adding Power Generation Sources**

When PG&E determines that its existing service facilities must be replaced, those facilities are replaced as a new service extension under the provisions of the tariff rules. The following subsections describe the requirements when existing electric service termination and metering equipment are replaced.

NOTE: When replacing existing electric service equipment, refer to [Section 2, "Gas Services," Subsection 2. .2.E., "Panel Replacements and Conduit Connections to Existing Electric Panels, 00 Amps and less, within the Gas Clearance Area,"](#) on Page 2- 6, for gas meter set clearance requirements from any type of electrical equipment and materials. Also see Figure 2-22, "Clearance Requirements for an Existing Electric Meter/Panel," also in Section 2. .2.E.

## 1 1 1 Upgrading Electric Facilities

An increase in the ampacity rating (e.g., 100 amps to 120 amps, 1,200 amps to 1,600 amps) of the equipment where PG&E terminates its service is typically defined as an upgrade. The ampacity rating also may be known as the service-entrance capacity. For example, when an applicant replaces an existing electric meter panel, switchboard, or termination enclosure with one that has a greater ampacity rating (i.e., upgrade), the applicant must meet all Greenbook requirements. Typically, this also includes installing new conduit and service conductors.

When a new meter panel is installed in a new location, the existing meter panel may not be used as a junction box to connect to existing load-side wires. The existing meter panel must be removed and covered by a solid, permanent exterior wall.

See the sections titled “Upgraded Panel” in the numbered documents below for conditions when the conduit or cable may not require upgrading, as determined by PG&E.

- [Numbered Document 06 927, “Methods and Requirements for Installing Residential Underground Electric Services 0–600 Volts to Customer-Owned Facilities”](#)
- [Numbered Document 06 928, “Methods and Requirements for Installing Non-Residential Underground Electric Services 0–600 Volts to Customer-Owned Facilities”](#)

## 1 1 2 Replacing Electric Facilities with Like-for-Like

Replacing service termination and metering equipment with new equipment of the exact same ampacity (e.g., 100 amps to 100 amps, 1,200 amps to 1,200 amps) and in the exact same location is considered a “like-for-like” replacement and typically is not considered an upgrade.

NOTE: Replacing a main or load breaker in an existing panel is not considered a panel replacement.

The following requirements apply to like-for-like panel replacements.

- All new meter panels and their locations must meet Greenbook requirements and be approved by PG&E.
- If the existing electric meter panel is fed from an overhead service and has an isolated cable termination compartment, separate from the meter socket compartment, the new meter panel must also have an isolated cable termination compartment. For example, see [Section 6, Figure 6-6, “Typical Service-Termination Enclosure, Combination Meter Socket Panel for a Class 20 Meter \(Residential, 120/200-Volt, 226-Amp Through 20-Amp Service\).”](#) on Page 6-10.

## Section 1, General

## 1.16.2. (continued)

- C. If the existing electric meter panel is fed from an overhead service and does not have a cable termination compartment, then the panel may be replaced with a new panel that does not have an isolated cable termination compartment. See [Section 6, Figure 6- , “Combination Meter Socket oad Center,”](#) on Page 6-9, for specific notes and requirements, and an allowed meter panel that does not have an isolated cable termination compartment. This type of panel may be replaced with one that has an isolated termination compartment.
- D. If the existing electric meter panel is fed from an underground service, the new meter panel must have an isolated cable termination compartment that is separated from the meter socket compartment. For example, see [Section 6, Figure 6-1, “Typical nderground Service-Termination Enclosure, Combination Meter-Socket Panel \( esidential, 0 Amps–22 Amps\),”](#) on Page 6- . ew panels without an isolated termination compartment are not allowed.
- E. ew multimeter panels must be the same shape, layout, dimensions, and number of meter sockets as the existing multimeter panel to be considered a like-for-like replacement. If any of these items are not met, the panel replacement will be considered an upgrade and must meet the upgrade requirements in Subsection 1.16.1., [“Upgrading Electric Facilities,”](#) on Page 1-21.
- F. The new service and metering equipment must be positioned so the existing PG&E service conductors can be terminated into the new panel lugs or studs. All-mounted junction boxes, underground splice boxes, or splicing on additional cable is prohibited and not allowed. The new equipment also must be positioned to ensure that clearances are not reduced to gas facilities (as shown in [Section 2, Figure 2-19, “Electric and Gas Meter Set Separation Dimensions and Clearances,”](#) on Page 2- ), water sources, or obstructions. If PG&E needs to install new service conductors or cables to perform the reconnect, the work and material is the applicant’s responsibility.
- G. A like-for-like panel change may not have to meet the current Greenbook requirements unless worker safety, existing clearances, working space, or the panel location’s accessibility is reduced or compromised. PG&E will not energize meter panel installations if they do not meet PG&E requirements for safe working conditions. This is at PG&E’s discretion. The following are additional cases where the panel is not allowed to be replaced in the same location.
- hen structures (e.g., decks, remodeled buildings, planters) are built over, under, or around the existing meter panel.

## 1.16.2. (continued)

- When the existing meter panel is installed directly above or within 12 inches horizontally from the outside edges of the gas meter set. This includes installations where the gas or electric meters are inside cabinets. If one or both of the meters are in cabinets, the 12-inch clearance is from the outer edge of the cabinet. See Figure 1- , “Panel Placement of Allowed when Over a Gas Meter Set,” below. Newly replaced meter panels are prohibited from being installed in the gray area.

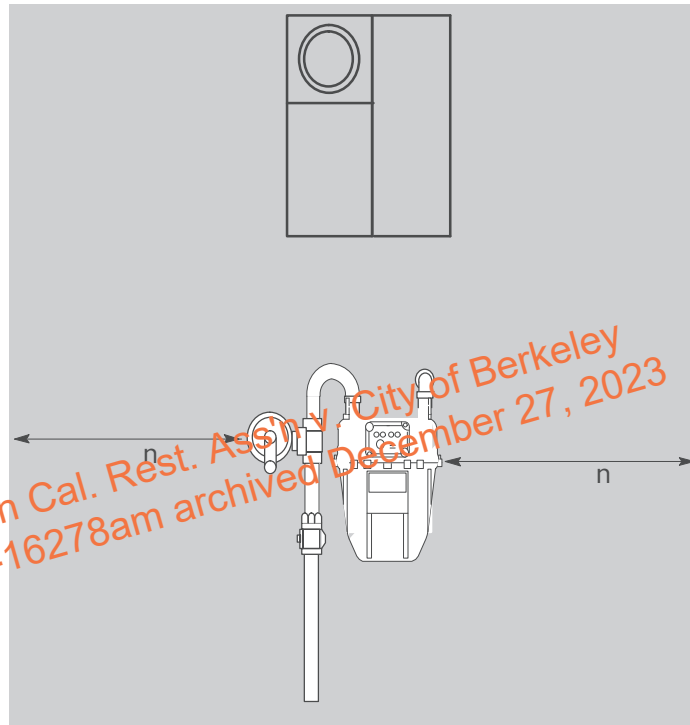


Figure 1-  
Electric Panel Replacement Not Allowed  
When Over a PG&E SmartMeter Gas Meter Set

## 1.1 Relocating Electric Facilities

When existing electric facilities are relocated, applicants must meet all of the current Greenbook requirements. If PG&E’s existing service conductor can be used, as determined by PG&E, the panel must be positioned so the service conductor can be reconnected properly. The existing service conductor must be able to be reconnected either to the underground electric panel termination lugs or, for overhead services, to the external service-entrance conductors coming out of the weatherhead.

If PG&E needs to install additional service conductors or cables to perform the reconnect, the work and material is the applicant’s responsibility. PG&E does not accept cable-termination techniques using pin adaptors, cable ringing, or splicing on additional cable.

1.16. . (continued)

For additional information, see [Section . , “Electric Metering: General.” Subsection . . , “Electric Meters: General ocation equirements.”](#) on Page - .

1 1 dding Po er Generation

All customer-generating equipment connected either to the Company’s equipment or to customer equipment must conform to Company standards. This includes any applicable municipal, local, city, or federal rules and regulations, unless otherwise specified. Any distributed generation (DG) facilities, as well as backup generation installations, must meet the clearance requirements detailed in the *Greenbook*. This includes all clearance requirements from gas facilities.

Examples of DG and backup generation facilities include, but are not limited to, renewable sources such as solar, wind, water power, and farm waste, as well as nonrenewable energy sources such as natural gas or other fossil fuels for conventional engines, turbines, and fuel cells.

1 17 Standard Electric Service oltage and oad imitations

This section clarifies PG&E’s voltage requirements when applicants design services for single-family residential homes; duplex homes, town homes, condominiums, apartment buildings, or commercial (nonresidential) buildings.

1 17 1 Single-Phase Service

Unless an applicant qualifies for a three-phase service, the service voltage for a residential building or structure typically is 20 2 0 , single phase, where the size of any single motor does not exceed . horsepower.

For any single-phase service, the maximum demand as determined by PG&E is limited to the capability of a 100-k A transformer. If the load requires a transformer installation in excess of 100 k A, the service will be three phase.

PG&E will not supply 120/208 , single-phase service to residential structures or buildings unless both of the following conditions are met.

- A. A 120/208 secondary system is established near the location where the requested service would be supplied.
- B. The rating of the disconnecting means (i.e., the main switch or main disconnect) or of the service entrance does not exceed 22 amperes.

1 17 2 Three-Phase Service

If PG&E determines that a single residential or nonresidential building or structure justifies a -k A transformer at 120/208 , or a horsepower or larger motor at 120/2 0 for an overhead service, then installing three-phase service is an option for the applicant. This option also is available for underground services with a -k A transformer at 120/208 , or a 10 horsepower or larger motor at 120/2 0 .

## 1.1 .2. (continued)

This applies whether the applicant plans to wire the individual residential units in a single-phase or a three-phase configuration. Applicants requesting the three-phase option must provide space on the property for PG&E to install a dedicated transformer. For more information, see [Electric Rule 2](#).

If, based solely on PG&E's estimation, the electric service demand is greater than that which can be supplied by a single-phase, 100-kVA transformer, then PG&E must supply three-phase service.

Other load limitations and requirements used to determine qualification for three-phase service are contained in PG&E's [Electric Rule 2](#).

Three-phase service is available in 208/120, 240/120, or 80/208 voltages. The appropriate voltage depends on the minimum load requirements and the maximum demand load permitted by PG&E's [Electric Rule 2](#).

## 1.1.7 Mixed-use Projects

Mixed-use projects include both residential and nonresidential loads. When designing a mixed-use project where the use occurs in separate buildings, ensure that each facility is supplied by a separate transformer. This means that a single-phase transformer could supply the residential unit(s) and three-phase transformer could supply the nonresidential unit(s).

If the mixed use occurs in the same building, a single transformer typically is installed to supply the building. The size and selection of the transformer is based solely on PG&E's estimated demand load. The applicant must provide space on the property for PG&E to install a dedicated transformer.

In some cases, PG&E may determine that the residential and nonresidential loads must be supplied by separate transformers and service facilities, including meters and metering facilities. PG&E makes this determination based on the nature or anticipated operation of the nonresidential loads and how they may affect the services. The applicant must provide space for those service facilities on the property.

Again, when developing mixed use projects, the applicant must communicate and work closely with PG&E early in the design phase.

## 1.1 Wholesale Distribution Tariff (WDT) Interconnections

DT customers requesting primary service interconnections should refer to [umbered Document 092816, " Wholesale Distribution Tariff \(WDT\) Interconnection Design Options for Primary Voltage Service."](#) located in and consult with your local service planning office.

Section 1, General

---

## 1.1 Harmful Wave Form

As described in [Electric Rule 2](#), customers must not operate equipment that either superimposes a current of any frequency or wave form on PG&E's system, or draws current from PG&E's system of a harmful wave form. Harmful wave forms cause interference with PG&E's operations, or with service to other customers, or cause inductive interference to communication facilities.

Also, any customer who operates or plans to operate any equipment that creates intolerable voltage fluctuations, generates waveform harmonic distortion, or otherwise causes intolerable service interference, must limit such interference or restrict the use of such equipment on PG&E's request.

Harmonic distortion is a growing power-quality concern on PG&E's distribution circuits. Therefore, PG&E will adopt the [Institute of Electrical and Electronics Engineers \(IEEE\) Standard 19, "Harmonic Control in Electric Power Systems."](#) PG&E will require that the harmonic current drawn by customer's equipment of any kind be in conformity with the [IEEE Standard 19](#). Customer equipment types include, but are not limited to, variable Frequency Drive (VFD) motor controllers. These harmonic distortion limits reduce the potential negative effects to customers and PG&E distribution system equipment.

As explained in [Electric Rule 2](#), customers may be required to install protection against the adverse effects of harmonics resulting from their equipment. Customers can reduce harmonic current by installing harmonic filters or upgrading to equipment with a low-harmonic output.

cited in Cal. Rest. Ass'n v. City of Berkeley  
No. 21-16278am archived December 27, 2023

# SECTION 2 G S SERVICE

*cited in Cal. Rest. Ass'n v. City of Berkeley  
No. 21-16278am archived December 27, 2023*

SECTION 2 G S SERVICE



SECTION 2 G S SER ICE

cited in Cal. Rest. Ass'n v. City of Berkeley  
No. 21-16278am archived December 27, 2023



Know what's below. Call before you dig.

## Section 2 Gas Service

### 2.1 Scope

This section of the manual covers general gas service and gas meter-set requirements for residential and nonresidential installations.



S



### WARNING

TO AVOID POTENTIAL ACCIDENTS, DO NOT BEGIN TO  
EXCAVATE BEFORE IDENTIFYING UNDERGROUND FACILITIES

State law requires applicants to contact Underground Service Alert (USA) *before* *dialing* *at least* *working days* *before excavation* (weekends and holidays excluded). Ensure that you call USA when planning underground work, before digging begins, to allow adequate time for USA to determine the location of underground gas and electric lines or equipment. *The potential for an accident exists if applicants fail to request USA to identify underground facilities before the beginning of excavation.* For safety, workers must dig by hand when digging within 2 feet of distribution lines and 10 feet of gas transmission lines.

First, the applicant must mark the excavation area with white paint. Then, USA arranges for participating companies to mark the locations of their underground facilities at the jobsite. *This is a free service.* See the USA color-code identifiers in Table 1-1, "USA Color Coding," on Page 1-1, and on the back of this manual.

Additional information is available at <http://www.pge.com/digsafely>. Find USA services at the USA north website (<http://www.usanorth.org>). USA is a locating service for excavation only. Do not use USA for design purposes.



Dig Safely

### 2.2 Procedures for Establishing Gas Service

#### 2.2.1 Establishing New Gas Service

Applicants must follow the steps described below to establish new gas service.

#### Applicant's Planning Stage

When planning to establish new gas service, applicants must:

1. Fill out and submit the appropriate PG&E application. Refer to Subsection 1.1, "Applying for Building and Renovation Services," on Page 1-1, for more information about the application requirements.
2. Contact their local PG&E project coordinators as early in the planning stage as possible.

NOTE See [Table FM-1, "Service Planning Office and Inspection Desk Contact Information,"](#) at the front of this manual starting on Page iv, for specific contact numbers listed by area.

## 2.2.1. (continued)

working with PG&E

After initially contacting PG&E about installing new gas service, applicants must:

1. Provide detailed site improvement plans indicating property lines, roads, sidewalks, and driveways, as well as the locations of other site infrastructure elements such as, but not limited to, water services, sewer line, water drainage, bioswales, and retaining walls. For individual parcels/single buildings, include the proposed locations of gas and electric meters, building elevations, and proposed future improvements. Ensure that the written details for required clearances in meter set assemblies are also included in the drawing. (Meter locations are subject to PG&E approval.)
2. Submit details about the type(s) of gas appliances being installed per meter. Include the connected load breakdown in thousand British Thermal Units (MBTU) per hour for each appliance and its intended use.

- Applicants requesting above-standard delivery pressure (inches of water column) typically are required to submit a written justification for PG&E's review and approval. Standard delivery pressure is approximately 1/2 pounds per square inch gauge (psig). See Subsection 2.1.1., "Gas Pressure," on Page 2-18, for more requirements.

Applicants can choose either PG&E or an outside company to design and/or install their services. PG&E provides the applicant with a bid for service design and installation costs. Specific conditions must be met whether the applicant chooses PG&E or an outside company to work on the project.

- When PG&E utilities are in a trench with other utilities, see [PG&E Standard S-100](#), "Joint Trench" (located in [Appendix B, "Electric and Gas Service Documents"](#)), Exhibit A, "Joint Trench Drawing," and Form B, "Job Estimate Authorization for Joint Trench Construction." *See the information in both exhibits when G&E facilities are in a trench with other utilities.*

Contact your local project coordinator for copies of these documents. See [Table FM-1](#) in the front of the manual on Page iv.

Information about service design and installation options is available either on [Gas Form 9-16, "General Terms and Conditions for Gas and Electric Extension and Service Construction by Applicant,"](#) or by calling PG&E's Building and Renovation Service Center (BSC) at 800-833-8282.

## 2.2.1. (continued)

6. Obtain approval from PG&E's project coordinators for the gas service and meter-set location. If the new gas service request is complex, PG&E may require that estimators and/or engineers become involved *before* approving the gas service and meter-set location.
7. Select a trenching agent to perform the required trenching and paving services. The trenching agent also must obtain all the permits required for installing the gas service pipe from the point of connection at the main to the approved meter location. Applicants can select either PG&E or an outside contractor to perform this work.

If an applicant selects an outside trenching agent for the project, the applicant must obtain a copy of PG&E's approved trench route or construction sketch. PG&E must inspect and approve any trenching and paving work performed by outside agents.

Outside trenching agents are required to be certified to perform work on the gas pipeline systems. For a complete list of tasks requiring certification, see the [Operator Qualification Program Requirements](#) or contact a PG&E project coordinator.

Outside trenching agents can be certified by scheduling a testing session directly with PG&E by calling 1-800-862-6222 (Option 1), or by emailing [qualification@comm.pge.com](mailto:qualification@comm.pge.com).

PG&E does not accept or assume ownership of additional facilities installed where the applicant begins construction *before the design is completed and approved by PG&E*. Additional facilities, even if provided at no cost to PG&E, represent increased plant in the rate base. This includes associated, long-term increases in taxes and maintenance expenses.

Applicants are responsible for any additional design changes or reconstruction costs that may be required if PG&E does not accept unapproved facilities. *Gas will not press rate as if it has not received final design approval and passed all inspections.*

8. Pay PG&E for all the installation costs. This includes the costs for facilities and appurtenant fittings, valves, service pipe, service regulators, metering equipment, etc., in excess of the allowances. For more information, see PG&E's [Gas Rule 15, "Gas Main Extensions," Section B, "Installation Responsibilities,"](#) and [Gas Rule 16, "Gas Service Extensions," Section E, "Allowances and Payments by Applicant."](#)
9. Install, own, and maintain physical protection such as bollards or barrier posts and/or enclosures, as may be required.

2.2.1. (continued)

C Complying with local building codes and Regulations

Applicants must contact local city and county deputies and inspectors to ensure compliance with all local laws and regulations. Applicants must:

1. Allow only qualified professionals to install applicant-owned facilities. Also, applicants must ensure that equipment required by local building codes are inspected by local building inspectors.
2. Complete the required inspections on applicant-installed gas piping (e.g., houselines) and equipment (e.g., valves, appliances) *before* scheduling meter-set work with PG&E.



Gas pp

2.2.2 Relocating or adding load to an *Existing* Service

An applicant should contact PG&E as early as possible when there are plans to remodel that require relocating an existing gas service to a different, acceptable location or when adding gas load. Applicants are required to fill out and submit to PG&E [Gas Form 62-068](#), “[Application for Service Existing Service Relocate/Change Service](#).” This form is located on [pge.com](#) at [https://www.pge.com/tariffs/assets/pdf/tariffbook/GAS\\_FO\\_MS\\_62-068.pdf](https://www.pge.com/tariffs/assets/pdf/tariffbook/GAS_FO_MS_62-068.pdf)

This form, along with additional information about building and renovation services, also is found at <http://www.pge.com/building/>. The form requires applicants to provide the following information

- **Project Type** Asks the reason for the relocation/rearrangement.
- **Project Information** Asks specific information about the project location and applicant.
- **Contract Information** Asks for the applicant’s legal name, mailing address, etc.
- **Representative Information** If the applicant has a legal representative to relay project information and updates to the PG&E representative, the legal representative’s name goes here.
- **Construction Information** Describes the applicant’s choices for trenching and backfill work.
- **Load Information** Asks for the number of existing meters at each service location. Provide details about the quantity and types of existing gas appliances and details of those being added. Include the connected load breakdown in thousand British Thermal Units (MBTU) per hour for each appliance. Also include a description of each appliance’s intended use.
- **Self Generation and Net Metering Options** Describes the requirements to apply for PG&E’s net metering program.
- **Attachments** Lists the documents required for the application including site improvement plans, drawings, and maps.
- **Agreement to Pay and Signature** Applicants must sign the agreement and pay any fees associated with the work.

*Water in Cal. Rest Ass'n v. City of Berkeley  
No. 21-16278am archived December 27, 2023*

## 2.2.2. (continued)

**NOTE** Adding load may cause the existing service to become inadequate and may require the service to be upgraded and/or replaced at the applicant's expense. (See [Gas Rule 16](#).)

Applicants can choose to provide trenching for gas services relocations. [PG&E Gas Form 62-068](#) describes these options in greater detail.

## 2 Gas Service

All plastic gas distribution service pipes and stub completions must be a minimum diameter of 1 inch for all new business installations and customer-requested service relocations.

## 2 1 General

A gas service is the section of plastic tubing or steel pipe that connects the service riser and gas meter to PG&E's gas distribution main. The gas distribution main is preferably located in an easement adjacent to the applicant being served. For an example, see Figure 2-1, "Typical Gas Service Installation," on Page 2-6.

Applicants should install the gas distribution mains in joint trenches, when it is feasible to do so. Locate distribution mains 3 feet from the face or foundation of any building as described in [Gas Design Standard A-0](#), "Cover and Clearance Requirements for Transmission Lines, Distribution Mains, and Service Lines." Located in Appendix C, "Electric and Gas Engineering Documents." On private property, ensure that easements are at least 10 feet wide for mains. Services that cross third-party property also require a 10-foot-wide easement.

A financial allowance for the installed service cost is based on the applicable, connected gas appliances installed within a specific time period. The allowance is applied toward the cost of a new service, as outlined in PG&E [Gas Rule 16, Section E](#).

A. When installing a gas service, PG&E performs the following actions.

**NOTE** While it is PG&E's responsibility to design and install the gas service, the applicant has the *option* to perform both.

1. PG&E installs a service extension and applies the gas rule allowances, based on applicant load, to the applicant under the following conditions:
  - a. PG&E determines that the loads to be served are bona fide.
  - b. The loads are connected and the extension placed into service subject to compliance with [Gas Rule 15](#) and [Gas Rule 16](#).
2. Design the PG&E-approved gas service to the shortest and most practical route, preferably in a straight line at a right angle from the gas main to an approved meter location. Avoid offsets, diagonal runs, bends, and services installed under driveways or customer-paved areas. Exceptions require PG&E's advance approval. When the building or structure is on a corner lot, PG&E determines the gas main for connection.

Section 2, Gas Service

2. .1. (continued)

- . Install and connect the gas service to the gas main in the adjoining street, highway, alley, lane, road, or easement.

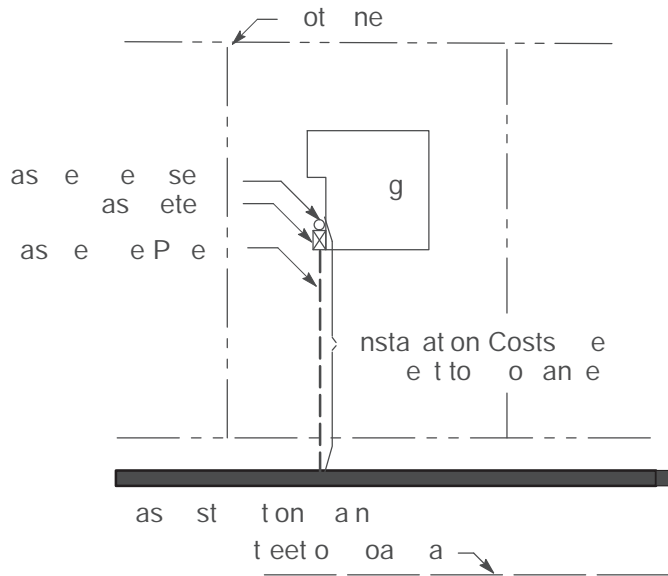


Figure 2-1  
Typical Gas Service Installation

*cited in Cal Rest. Ass'n v. City of Berkeley  
No. 21-16278 am. approved December 27, 2023*

- . refer to [Gas Design Standard A-9](#) . . , “Excess Flow valves,” located in [Appendix C](#).

refer to Subsection 2. . . , “Curb valves,” on Page 2-10, if a curb valve is required.

- 6. Do not install gas services under or through retaining structures (e.g., retaining walls) greater than feet above ground.

**NOTE** A retaining wall is a structure that retains (i.e., holds back) material (usually earth) and prevents it from sliding or eroding away. Retaining walls are designed to resist the pressure of the material being held back.

B. PG&E does not permit the following types of installations.

- 1. Installing gas service under or through structures, buildings, foundations, or decks. On an exception basis, PG&E may approve a gas service riser in a gas meter room that meets the requirements in [Gas Design Standard -16, “Gas Meter room,”](#) located in [Appendix C](#).

**NOTE** If PG&E determines that an applicant’s uninspected trench excavation requires repair, or if the uninspected trench is backfilled and/or paved over, the applicant must provide and pay for all of the paving services and permits that are required to get an inspection and repair the trench excavation completely. This includes trenches dug on both public and private property.

## 2. .1. (continued)

2. Installing gas service and gas service risers directly into concrete or asphalt pavement materials.

. Installing gas service risers that are not approved by PG&E.

C. When installing a gas service, the applicant is responsible for ensuring the following conditions are met.

NOTE Applicants must refer to PG&E [Gas Form 9- 16](#) when they propose installing new gas services for new business utility services. This form is located on the [Tariffs](#) website on [pge.com](#) at <https://www.pge.com/tariffs/index.page>.

1. Provide and maintain a clear route, free of any obstructions, for installing the gas service facilities.

2. Trench, backfill, and perform any other digging as described in PG&E's specification and inspection instructions, as required.

. Pay any required permit fees.

. Install and maintain all of the gas piping downstream of the service delivery point. See Subsection 2. ., "Applicant-Owned and Installed Gas-Service Piping (e.g., ouseline) valves, and Automatic Shut-Off Devices," on Page 9, for more information.

. Ensure that all requirements are met in the following PG&E gas design standards, located in [Appendix C](#).

6. Notify PG&E as soon as any paving activity is planned and provide PG&E with the scheduled completion date. Applicants should remember that PG&E can meet their schedules when the Company is notified early in the process.

. PG&E must approve all requests for gas service in a casing before installation. Provide and install an approved casing (i.e., sleeve) under the paving material when the paving will extend over the gas service. Applicants must ensure that:

a. The casing is made of a PG&E-approved material. Refer to [Gas Design Standard A-](#), located in [Appendix C](#).

b. PG&E employees and equipment have sufficient, safe, and unobstructed access to the casing location with sufficient space to perform any required work when installing in a joint trench.

c. Before installing any type of pavement or concrete, place a minimum -inch sleeve around the gas service riser.

cited in Cal. Res. Ass'n v. City of Berkeley  
No. 21-16278am archived December 27, 2023



## 2. .1. (continued)

8. PG&E Procedure TD- 6 2P-01, “Gas and Electric Operations – Cross Bore Prevention and Mitigation,” provides the steps that must be taken to prevent, inspect, identify, report, and address cross bores that are created when PG&E, its contractors, and contracting agencies perform trenchless construction. All construction work performed by or for PG&E is subject to this procedure.

NOTE Find additional information about cross bores at the Sewer Cleaning website:  
[https://www.pge.com/en\\_US/safety/gas-safety/sewer-cleaning-safety.page](https://www.pge.com/en_US/safety/gas-safety/sewer-cleaning-safety.page)

- D. For more information and illustrations, see Company Standard S, Exhibit B, Joint Trench Configurations Occupancy Guide, located in Appendix B.
- E. Underground warning tape is required for all gas service and main pipeline installations as described in Gas Design Standard -16, “Gas Pipeline Underground Warning Tape,” located in Appendix C.
- F. Figure 2-2, “Gas-Only Service Trench ” Figure 2- , “Typical Gas Bell Hole–Plan View ” and Figure 2- , “Typical Bell Hole Depth–Profile View,” show the typical, PG&E-required excavation for a gas-only service trench and gas bell hole. All three figures are located on Page 2-9. See Gas Design Standard A-9, “Gas Trench Design and Construction” located in Appendix C, for gas-only service trenching requirements.

cited in Cal. Post. Ass'n v. City of Berkeley  
No. 21-16278am archived December 27, 2023

2. .1. (continued)

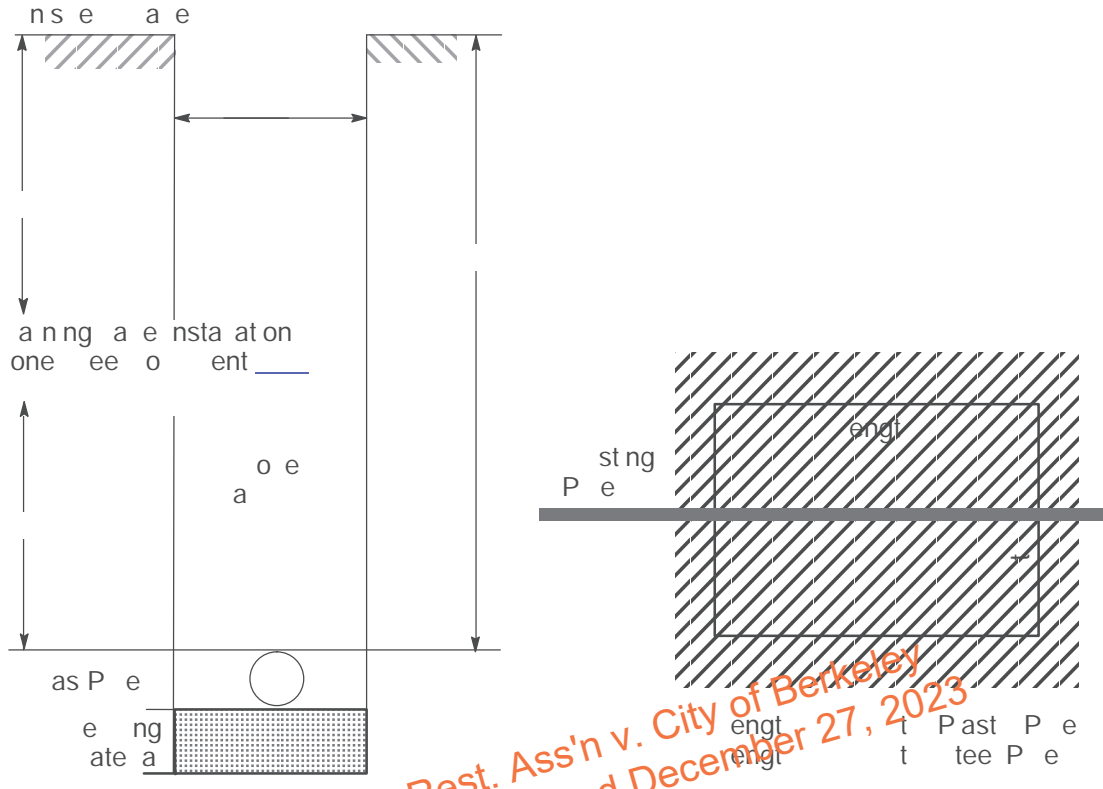


Figure 2-2  
Gas-Only Service Trench

Figure 2-  
Typical Gas Well Hole-Plan View

*cited in Cal. Rest. Ass'n v. City of Berkeley  
No. 21-16278am archived December 27, 2023*

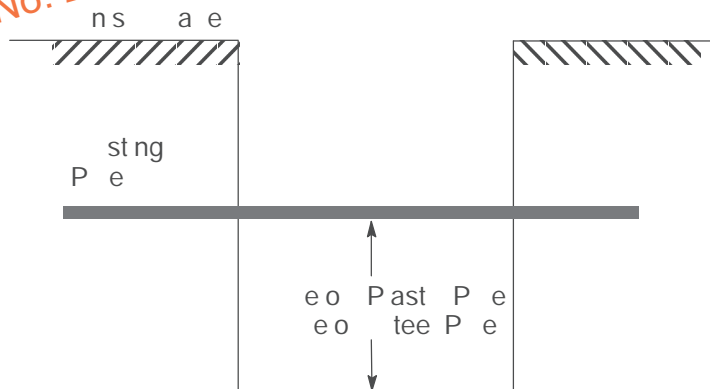


Figure 2-  
Typical Well Hole Depth-Profile View

Notes in reference to Figure 2-2, Figure 2-, and Figure 2- .

1. All dimensions are the minimum required amounts.
2. For Figure 2-2, "Gas-Only Service Trench," soil compaction must meet PG&E's and any applicable federal, state, county, and local requirements.
- . Some jobs may require bell holes with larger dimensions and trench shoring.

2 2 ranch Service Pipe

*ranchin a be sed to pro ide ser ice to no ore than t o b ildin s.*  
The meter installations must be located on adjacent sides of the two buildings being served. here a branch-service installation is justified, a separate location for the gas meter and electric meter is permissible, if necessary.

Design and install all branch services as described in [Gas Design Standard A- 2, "Standard Branch Service Installation,"](#) and [Gas Design Standard A-90,](#) both located in [Appendix C.](#)

2 Curb valves

A. A curb shutoff valve is required to be installed when any of the following conditions exist:

1. The meter capacity exceeds 5,000 standard cubic feet per hour, and an EFV is not required and not installed. Refer to [Gas Design Standard A-9 . . ,](#) located in [Appendix C,](#) for EFV requirements.
2. The shutoff valve is not readily accessible or is inside a building and the service shutoff valve is enclosed (e.g., basement, garage, or similar obstructed location).

. An EF is not required and not installed, and the service line cannot be quickly squeezed off because of wall-to-wall paving, concrete, depth of cover, or other surface conditions. This includes known, planned depth of cover or other surface conditions. Typically, a service line that is installed in a lawn area with normal soil conditions (i.e., no wall or wall paving, concrete, or other obstruction over the service line) may be quickly squeezed off.

*cited in Cal. Rest. Ass'n v. City of Berkeley No. 21-16278 as archived December 27, 2023*

B. PG&E *re ires* curb valves when the service line supplies a building where approximately 100 or more people gather and where the occupancy may be transient (see [Gas Design Standard A- .2, "Curb alves"](#)). Examples include, but are not limited to:

- Schools
- ospitals
- Churches
- Places of incarceration
- Theaters
- Auditoriums
- Arenas
- Transit centers

2. . . (continued)

C. PG&E *require* valves on small, gas-distribution systems. These systems include, but are not limited to:

- Mobile home parks (*not* individual mobile homes)
- Condominiums and apartments
- Multiple buildings
- Shopping centers
- Commercial/industrial parks

2 Joint Utility Service Trenches

When installing underground electric service, PG&E's gas service usually is installed in a common joint trench with the electric service. The joint trench typically includes telephone and cable television facilities. No other utilities or wiring are allowed in a joint trench (e.g., water, sewer, private wires, or facilities not a member of Underground Service Alert). See the definition for "joint utility" in [Appendix A, "Acronyms and Glossary."](#)

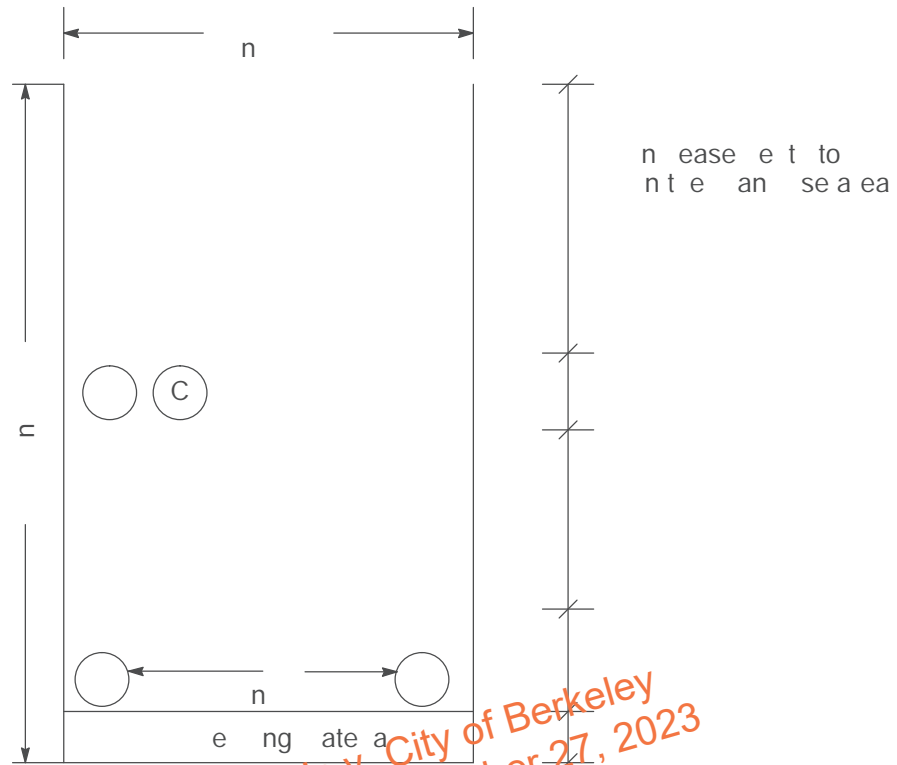
When planning to install joint-trench, allow for additional lead time to design and engineer the joint trench. Applicants must be aware of the following requirements.

1. Both a Joint Trench Composite Drawing and [Form B, "Job Estimate Authorization for Joint Trench Construction,"](#) are required when PG&E facilities are located in a trench with other utilities.
2. Applicants either must submit joint trench drawings to PG&E for review, or PG&E can prepare joint trench drawings for applicants at their expense.
3. PG&E must approve the trench's design details *before* trenching begins and facilities are installed.
4. Figure 2- , on Page 2-12, shows the layout of a "Typical Joint-Service Trench."

Separation and clearance details for joint utility service trenches are located in Table 2-1, "Minimum Separation and Clearance Requirements for Trenches," on Page 2-1 .

Section 2, Gas Service

2. . . (continued)



cited in Cal. Rest. Ass'n v. City of Berkeley  
 No. 21-16278am applied December 27, 2023

Figure 2-1  
Typical Joint Service Trench

Notes in reference to Figure 2-1:

1. Trench depth varies depending on the occupant's facility allotment.
2. Soil compaction must meet PG&E's, and any applicable federal, state, county, and local requirements.
3. A joint service trench must meet all separation and clearance dimensions shown in Table 2-1, "Minimum Separation and Clearance Requirements for Trenches," on Page 2-1.
4. For more information on Figure 2-1, see PG&E's [Joint Trench Configurations Occupancy Guide](#), located in [Appendix B](#).

2. . . (continued)

Table 2-1 Minimum Separation and Clearance Requirements for Trenches<sup>1</sup>

	G	Duct T	D T	C	S	P	S
(In Inches)							
G	as						
T	ee one t						
T	ee one e t						
C	C						
S	e t e on a						
P	e t P a						
S	t eet g t						
NE	o egn e t o es on P						

se a at on ea an e stan es a e n n es  
o o e no at on a o t t sta e see [Co an etn](#) ate e a at on e e ents o  
[Con t n ont en](#) o ate n en  
t eet g t ts **not o ned** P st e n sta e to eet t e e e ents n P s [Joint Trench  
Configurations & Occupancy Guide](#) e a a ants st e e t e e e ents o o ng t ase on  
t t o an  
Cons ee a t t as e ne n [t t tan a ont en](#)

PG&E does *not* differentiate between the clearances for casing/conduit and pipe. The clearances and installation requirements are the same.

For more information on backfill-sand requirements, see [Engineering Manual Specification EMS- 12](#), “Backfill Sand,” located in [Appendix B](#).

For more information on the minimum separation and clearance requirements for service trenches, see the [Joint Trench Configurations Occupancy Guide](#).

When different service facilities (e.g., gas, electric, telecommunications) are installed in close proximity (e.g., in a joint trench), applicants must ensure that the facilities maintain a minimum horizontal separation of 6 inches from the gas riser where they transition from below ground to above ground. See Figure 2-19, “Electric and Gas Meter Set Separation Dimensions and Clearances,” on Page 2- .

Clearances between other facilities can be reduced *only* when the parties supplying those services or facilities reach a mutual agreement.

**NOTE** Applicants must ensure that sufficient space is provided between facilities at all times to allow for safe maintenance and operation.

A. Applicants must *not* install any electrical devices or equipment including wires, cables, metering and telecommunication enclosures, bond wires, clamps, or ground rods within 6 inches of the gas service riser.

2. . . (continued)

This distance can be reduced to 18 inches for electrical devices or equipment certified for National Electric Code (NEC) Class I, Division 2 locations. See Figure 2-19, “Electric and Gas Meter Set Separation Dimensions and Clearances,” on Page 2- , and Figure 2-21, “Gas Regulator Set Clearance Requirement from Air-Intake and Exhaust Fans,” on Page 2- 6.

- B. Applicants must keep the area immediately behind gas meters, service facilities, and risers free and clear of all other facilities or equipment (i.e., pipes, building vents, or conduits). This requirement also applies to the area between those facilities and the premises or structure being served.

Before installing utility conduits or gas service piping, applicants must discuss the service arrangements and coordinate the final PG&E-approved meter locations and joint trench requirements with a PG&E project coordinator.

The joint trench composite drawing must include details of the sizes and quantities of all the equipment sharing the trench. *Gas inspectors inspect the trench after installation is complete.*

Applicants must ensure that the gas and electric meters are installed according to Figure 2-19 on Page 2- , providing the minimum separation clearances. Refer to the following sections of this manual for acceptable electric meter utility locations.

- [Section 2, “Gas Service,” Subsection 2. . . “Set Requirements for Gas Meters” \(on Page 2-18\)](#)
- [Section 4, “Electric Metering: General”](#)
- [Section 6, “Electric Metering: Residential”](#)
- [Section 7, “Electric Metering: Nonresidential, Industrial, and Agricultural”](#)

Wet utility piping or facilities are *not* permitted in a joint trench. Examples of wet utilities that are not allowed in a joint trench include the following:

- Propane lines
- Pressurized water lines
- Sewer, sanitary, or storm drains

Both [PG&E Standard S , Form B, “Job Estimate Authorization for Joint Trench Construction,”](#) and the [Joint Trench Configurations Occupancy Guide](#), located in [Appendix B](#), describe the requirements for separating a wet utility from a joint trench.

When applicants want to install facilities in a joint trench other than those listed in this section, PG&E requires a *written* request that includes a justification for the exception. Applicants must submit their requests to PG&E for review and approval *before* beginning work on a joint trench.

See Figure 2-19 on Page 2- for above-grade clearance requirements from the gas service riser where joint trench occupants terminate.

- 2 Multiple buildings located on One lot
- Two buildings located on One lot

1. PG&E may furnish a separate gas service to each building if it does *not* require an additional gas distribution main extension.

Figure 2-6, "Separate Gas Services for Two Buildings on a Single lot," on Page 2-1, and Figure 2-7, "Separate Gas Services for Two Buildings on a Corner lot," on Page 2-16, show examples of two premises on one lot with separate gas services.

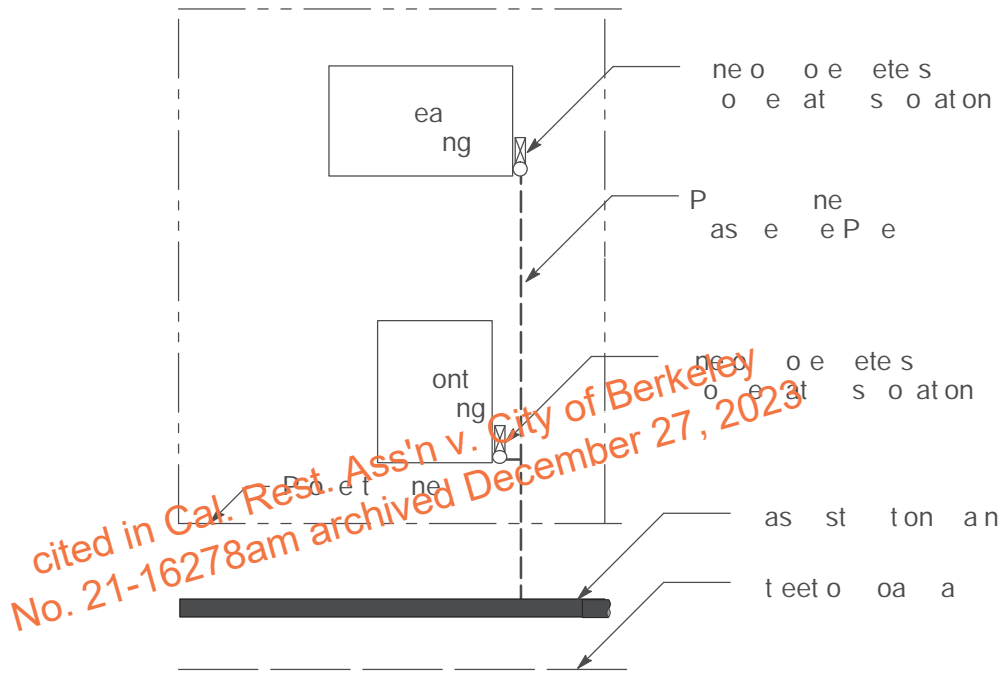


Figure 2-6  
Separate Gas Services for Two buildings on a Single lot



Section 2, Gas Service

2. . . (continued)

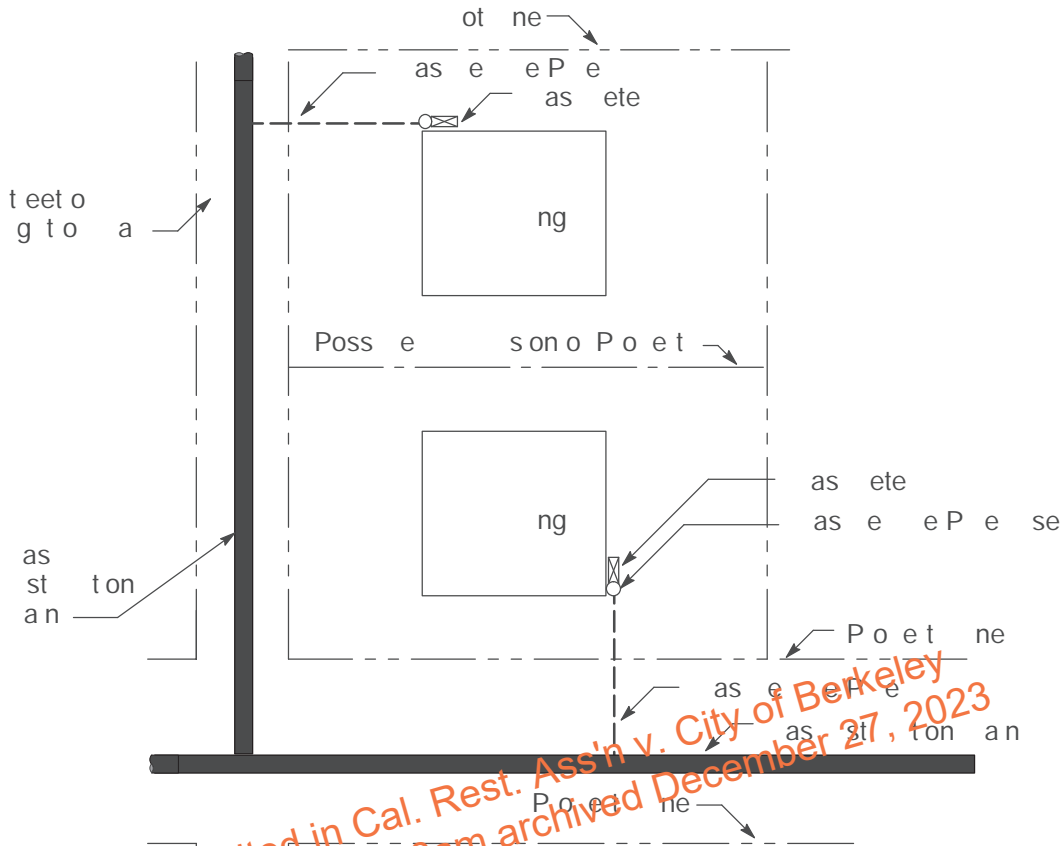


Figure 2-7  
Separate Gas Services for Two Buildings on a Corner Lot

2. When more than one gas meter is required to serve a single building, the meters for that building must be grouped at a common location that has been approved by PG&E. See Subsection 2. .2.F., “Multiple Gas Meter Connection Requirements for Single and Double (Banked) Manifold Connections,” on Page 2- 9, for grouping requirements when locations have multiple meters.

Three or More Buildings Located on One Lot

When two or more buildings, either single family or multifamily, are on the same lot and located in close proximity to each other, PG&E may install a gas distribution main on the applicants’ properties. For specific requirements, see PG&E’s main-extension rule, [Gas Rule 15](#), and service-pipe extension rule, [Gas Rule 16](#). Before a gas distribution main can be installed, applicants must ensure that the following conditions are met.

1. There must be a protected and accessible location on the property.
2. A satisfactory right-of-way, easement, or permit must be available at no cost to PG&E.

Typically, PG&E installs a single, gas-service pipe to each building, as described in [Gas Rule 16](#).

## 2. . . (continued)

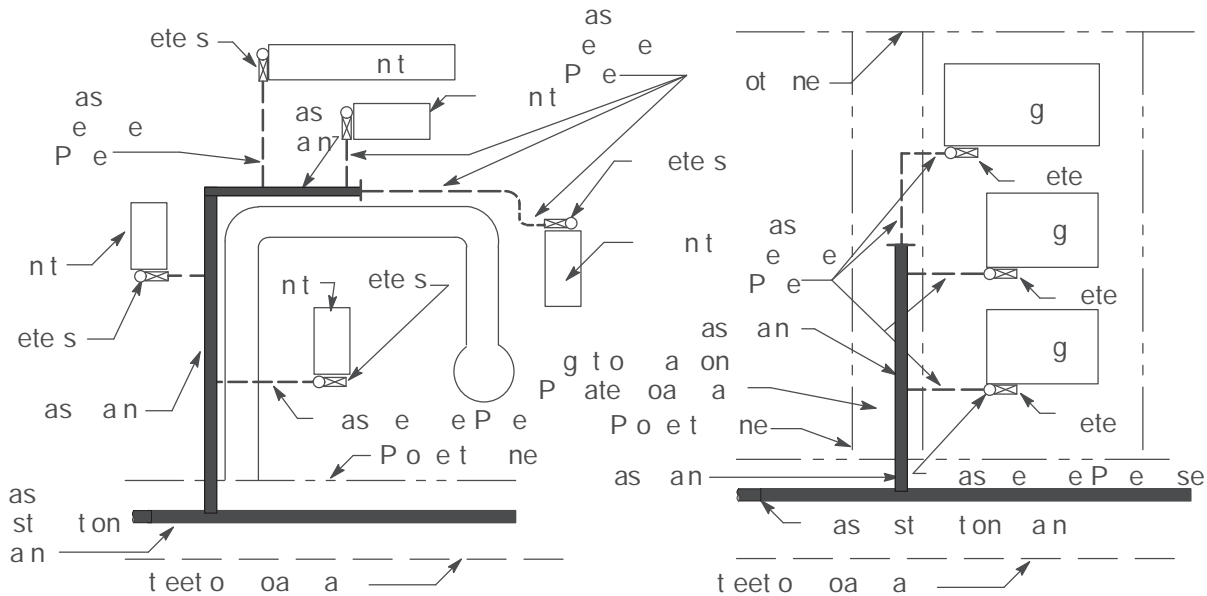


Figure 2-  
partments  
with Grouped Meter Locations

Figure 2-  
Individually Metered Buildings

Typical Gas Distribution Mains and Service Pipe Installation  
for Property with Three or More Buildings

Multifamily residential complexes are subject to a California Public Utilities Commission (CPUC) mandate specifying that each unit is metered individually. Specifically, see [Public Utilities Code Division 1, "Regulation of Public Utilities," Part 1, "Public Utilities Act," Chapter 1, "Regulation of Public Utilities," Article 1, "Equipment, Practices, and Facilities," Section 80.](http://leginfo.ca.gov/faces/codes_displaySection.xhtml?sectionNum=80.0&lawCode=PUC) (on the Internet at [http://leginfo.ca.gov/faces/codes\\_displaySection.xhtml?sectionNum=80.0&lawCode=PUC](http://leginfo.ca.gov/faces/codes_displaySection.xhtml?sectionNum=80.0&lawCode=PUC)).

**EXCEPTION** A single gas meter may serve an entire complex when the gas is used only for central heating systems (i.e., space, water) that supply all tenants in common, and when each individual unit does *not* use gas appliances that require combustion venting. Refer to [Gas Rule 18, "Supply to Separate Premises and Submetering of Gas."](#)

When each dwelling unit includes ground-floor space, each unit may have an individual service pipe and separate meter location *if*:

1. Sufficient meter space is provided.
2. Local ordinances do *not* prohibit such arrangements.

When it is practical, install the gas service pipe in a joint trench with the electric service.

See Subsection 2.2.F. on Page 2-9 for specific requirements when locations have multiple meters.

2 Mobile Home Parks

Gas mains and services in mobile home parks must meet the same standards for gas installations that are required for residential and nonresidential applications.

In addition, applicants must *not* install gas mains, services, and meters under existing or proposed structures including mobile homes, sheds, porches, carports, and stairs.

Applicants should install the gas distribution mains in the roadway, when it is practical to do so, and in joint trenches, when it is feasible. Locate distribution mains  $\frac{1}{2}$  feet from the face or foundation of any building as described in [Gas Design Standard A-0](#) located in [Appendix C](#). On private property, ensure that rights-of-way are at least 10 feet wide for mains and at least  $\frac{1}{2}$  feet wide for service piping. Only use easements for utility installations. Table 2-1 on Page 2-1 shows the minimum separation and clearance requirements for service trenches.

NOTE Curb valves are *not* recommended for individual mobile home services however, a curb valve may be installed on the service to a park’s community building.

NOTE Refer to [Gas Design Standard -12. ., “Mobile Home/Manufactured Home Meter Set Installation.”](#) Contact your local project coordinator for this document.

Also see the gas meter set requirements in Subsection 2. .2.A. ., “Mobile Home Parks,” on Page 2-2

*cited in Cal. Rest. Ass'n v. City of Berkeley  
No. 21-16278am archived December 27, 2023*

2 Set Requirements for Gas Meters

The following information describes the meter set requirements for gas services.

2 1 Gas Pressure

The following information describes the types of delivery pressures available with gas service.

Standard Delivery Pressure

PG&E typically will provide gas service pressure to the service delivery point at  $\frac{1}{2}$  inches of water column (WC). This is approximately 1/2 psig, as measured at the gas meter outlet.

Elevated Delivery Pressure

PG&E may be able to provide gas service at higher gas-delivery pressures, depending on the location of the applicant’s facility and on the requirements of the gas system serving that location. PG&E maintains sole authority to determine if the elevated delivery-pressure service is available at a specified location.

## 2. .1. (continued)

In all elevated delivery-pressure service situations, PG&E reserves the right to reduce the gas service pressure to standard delivery pressure, as outlined in [Gas Rule 2](#), “Description of Service,” when:

- PG&E determines that the elevated gas pressure is no longer available.
- The current delivery pressure is detrimental to PG&E’s gas distribution system.

**NOTE** When providing elevated gas-pressure service, PG&E can incur additional costs. In these cases, special facilities charges will apply as described in [Gas Rule 2](#). Applicants must pay these charges *before* PG&E can provide the services.

The following two numbered items describe cases where special facilities charges can apply.

1. **1 or 2 psig Services** In many PG&E service territories with sufficient distribution operating pressure, 2-psig delivery pressure may be available. When completing PG&E’s [Application for service process](#) online form, applicants must request 2-psig gas-service delivery pressure in the “Load Information” section. Generally, there are no special facilities charges at or below 2 psig for meters equal to or less than 1,000 standard cubic feet per hour (scfh) nominal capacity. As mentioned previously, PG&E determines if special facilities charges apply.

2. **1 or 2 psig Services Higher Than 2 psig** Elevated gas-metering pressures higher than 2 psig may be available from the local gas distribution system. PG&E must ensure that tapping into this existing service will *not* be detrimental to the operation of that gas system.

When requesting elevated gas-service delivery pressure higher than 2 psig, applicants must follow these steps.

- a. Contact the local PG&E project coordinator as soon as possible (preferably in the *planning* stage for a new or remodeled building).
- b. Fill out the appropriate PG&E [Application for service process](#) online form and note the gas-service delivery pressure being requested in the “Load Information” portion of the form.
- c. Submit a formal, written request and justification for elevated gas-service delivery pressure (e.g., the hypothetical houseline diameter size at standard delivery pressure, the appliances’ specification requirements).
- d. Submit a houseline piping schematic.
- e. Submit the manufacturer’s appliance specifications to ensure that the appliances will operate as designed.
- f. Provide detailed load information for all appliances and their intended use.

2. .1. (continued)

C Back-Pressure Protection

PG&E may require the applicant to install a check valve after the PG&E gas meter’s set point of connection. This check valve prevents backflow. PG&E determines the need for check valves on a case-by-case basis. The applicant is required to have a maintenance plan and to maintain the check valve.

For all higher-than-standard delivery pressure, PG&E recommends that applicants hire a qualified person, such as plumber or contractor, to review the applicant-owned gas piping, venting, and appliance installations for the gas pressure service being requested. The qualified person can ensure that the installations comply with all local, state, and federal codes, standards, and regulations. Specifically, the qualified person helps to ensure that the Uniform Plumbing Code is enforced based on the installation requirements of the local governing agency in the applicant’s location.

2. 2 Gas Meter-Set Locations

Typically, PG&E provides only one meter set (in an outside location) for each dwelling unit and one service to each building. PG&E may require that the meter be set at the property line if either of the following two conditions are met:

1. The building is back more than 200 feet from the property line.
2. A potential hazard or unusual site condition threatens the service between the property line and the building. Some examples of unusual site condition are plowed land, ditches, bridges, ponds, waterways, leach fields, bioswales, inaccessible security areas, or other deterrent, obstacle, or hazard.

PG&E prefers that rotary meter sets be located outside of and away from the building.

PG&E must have unrestricted, drive-up access for service trucks and adequate space to install and maintain the meter.

Any deviations require advanced approval from PG&E.

For specific information, see Gas Rule 16, Section C, number , “ Unusual Site Conditions.” Figure 2-10, “Property Line Installation,” below, shows a property-line meter set installation.

## 2. .2. (continued)

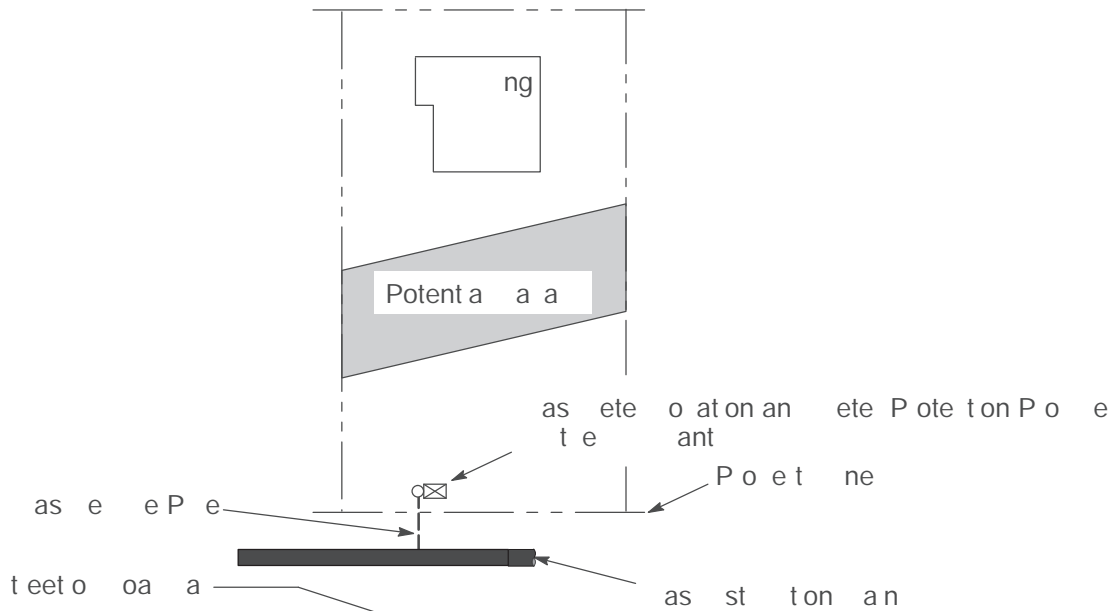


Figure 2-10  
Property Line Installation

**A. Descriptions of Acceptable Meter Locations**

For descriptions of, and specific requirements for, acceptable gas meter locations, see [Gas Design Standard -1, "Gas Meter Locations,"](#) located in [Appendix C](#).

Figure 2-11, "Acceptable Locations for Gas Meter Installations," on Page 2-2, and Figure 2-12, "Acceptable Meter Locations for Mobile Home Parks," on Page 2-2, illustrate locations that are acceptable for installing typical meter sets.

**. Required Access**

PG&E employees require access to gas meter sets to perform inspection and maintenance activities. When gas meter locations are approved by PG&E and are installed in areas that are locked or can potentially be inaccessible, the applicant must allow PG&E employees access to the meters.

- a. Use a lock box, provided by PG&E and installed by the applicant, to hold the applicant's key. The lock box with key must be installed in a PG&E-approved location near the gas meter access point.
- b. For gates, a double-lock device (e.g., hasp) may be required with one lock for the applicant and one lock for PG&E.

2. .2. (continued)

**2. Approved Meter Set Locations (In Order of Preference)**

**NOTE** For specific requirements and definitions, see [Gas Design Standard -1](#), located in [Appendix C](#).

- a. Meter set located outside a building including property-line meter sets.
- b. Meter set located outside in an alcove as described in Subsection 2. .2.G.1., “Alcoves,” on Page 2- 1.
- c. Enclosures as described in Subsection 2. .2.G.2., “Enclosures,” on Page 2- 2.
- d. Meter set located in a cabinet or closet as described in Subsection 2. .2.G. ., “General Requirements for Meter Cabinets,” on Page 2- , and Subsection 2. .2.G. ., “Gas Meter Closets,” on Page 2- .
- e. Meter set located in a breezeway. An acceptable breezeway is permanently open at both ends with no sources of ignition and no openings into the building.

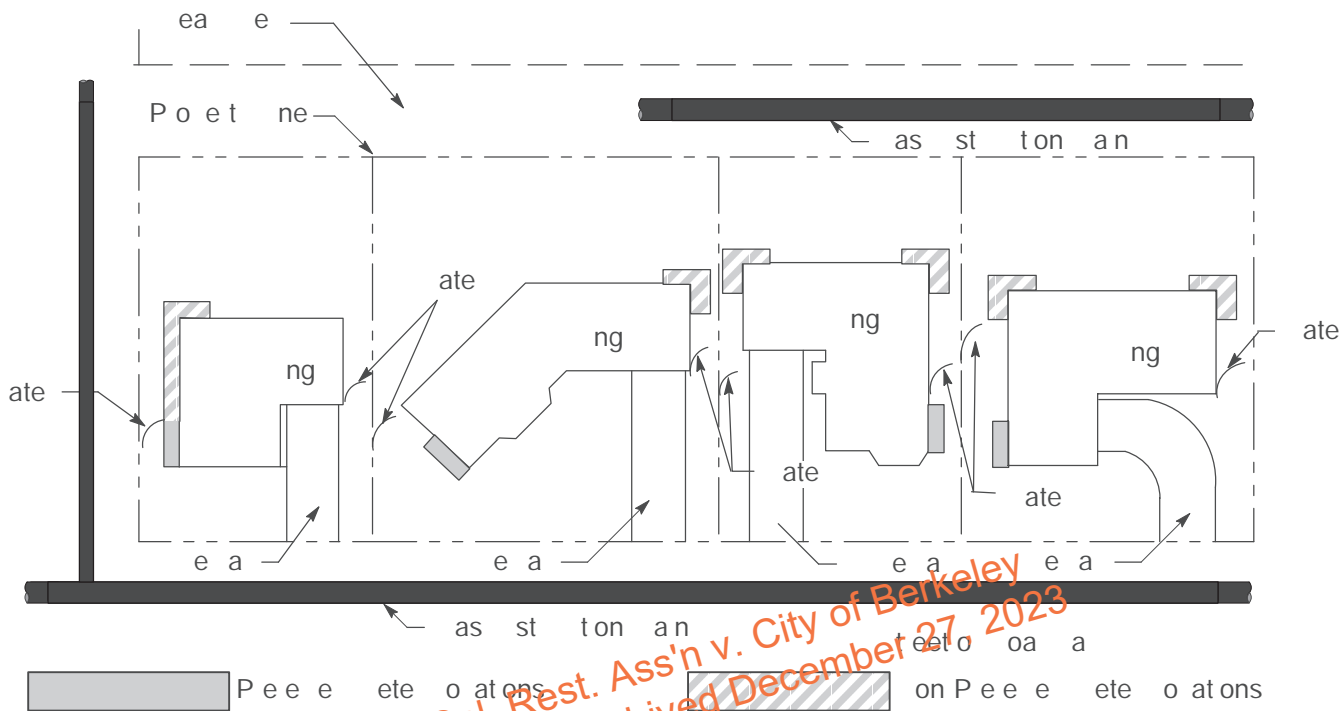
**NOTE** PG&E will consider approving number f. and number g., below, on an exception basis only after number a. through number e., above, are ruled out as options. Number f. and number g., below, typically are limited to structures built up to the property line with space restrictions.

- f. Meter set located inside a building in a gas meter room (see [Gas Design Standard -16](#) located in [Appendix C](#)).
- g. Meter set located in a buried vault, pit, or box.

*cited in Cal. Res. Ass'n v. City of Berkeley  
No. 21-16278am archived December 27, 2023*

2. .2. (continued)

3. Single Residential, Apartment, or Nonresidential Building



*cited in Cal. Rest. Ass'n v. City of Berkeley  
 No. 21-16278am archived December 27, 2023*

Figure 2-11

Acceptable Locations for Gas Meter Installations

**NOTE** When the meter set from the gas distribution line is located in a rear alley, applicants should locate the meter set outside of any gated or fenced area. This allows access for PG&E employees when maintenance is required.

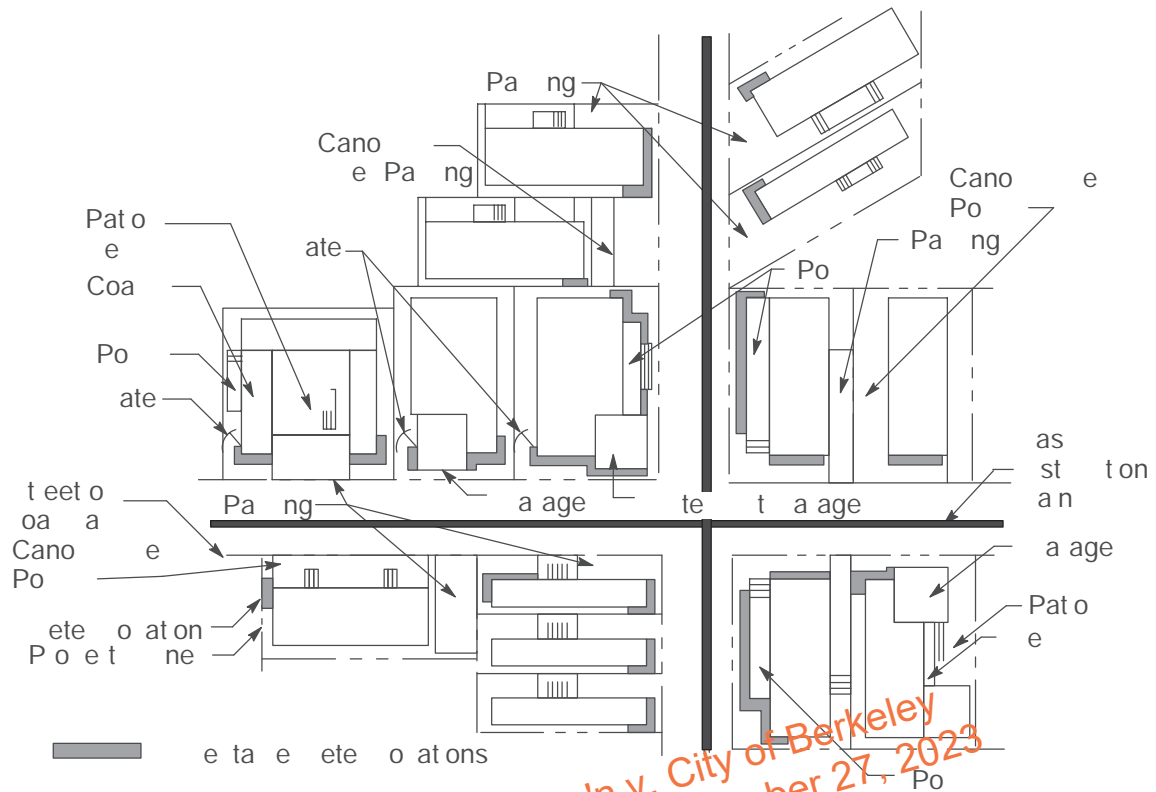
Mobile Home Parks

For new mobile home parks, the mobile home park owner or operator must provide a separate and independent meter location for each lot. New mobile home parks are not allowed to have submetering facilities.

Typically, meters are located on flat surfaces that are not obstructed by landscaping. Meter locations cannot be obstructed by porches and stairs leading to porches. Figure 2-12, on Page 2-2 , represents several acceptable meter locations within a typical mobile home park.



2. .2. (continued)



cited in Cal. Rest. Ass'n v. City of Berkeley  
 No. 21-16278am archived December 27, 2023

Figure 2-12  
 Acceptable Meter Locations for Mobile Home Parks

PG&E does *not* provide metering facilities if they will be attached directly to a “movable” mobile home unit that is installed or set up in any location, including a mobile home park. Before PG&E provides metering facilities, the mobile home must meet *both* of the following conditions.

- a. **Fixed in Place** The mobile home typically does not have either running gear or wheels and is not capable of being moved to another location.
- b. **Installed on a Foundation System** The mobile home must have a foundation system as described on the [California Department of Housing and Community Development](#) website. From the [Home](#) page, click [Manufactured & Mobilehomes](#). Then from the drop down, click [Mobilehome Parks](#). Finally, click [Laws and Regulations](#).)

This section says that if a mobile home park contains lots or site spaces that are set up to accommodate “movable” mobile home units, PG&E will install and supply the park using utility-approved service and metering facilities at a fixed location other than the mobile home. In these cases, applicants are responsible for connecting their mobile home units to those fixed metering facilities.

## 2. .2. (continued)

## . Subsidence Areas

In subsidence areas, the acceptable location requirements are the same as the requirements outlined in Subsection 2. .2.A., “Descriptions of Acceptable Meter Locations,” on Page 2-21. PG&E may require a flexible connector to be installed between the gas meter outlet and the houseline. These connectors may require additional clearance space. See Figure 2-1 , “Flex- ose Meter Set– esidential and Small Commercial,” located below, for a sample installation. Contact your local project coordinator for [Gas Design Standard - 8, “Flex ose Meter Set Installation,”](#) which provides information about diaphragm and rotary meters in subsidence areas.

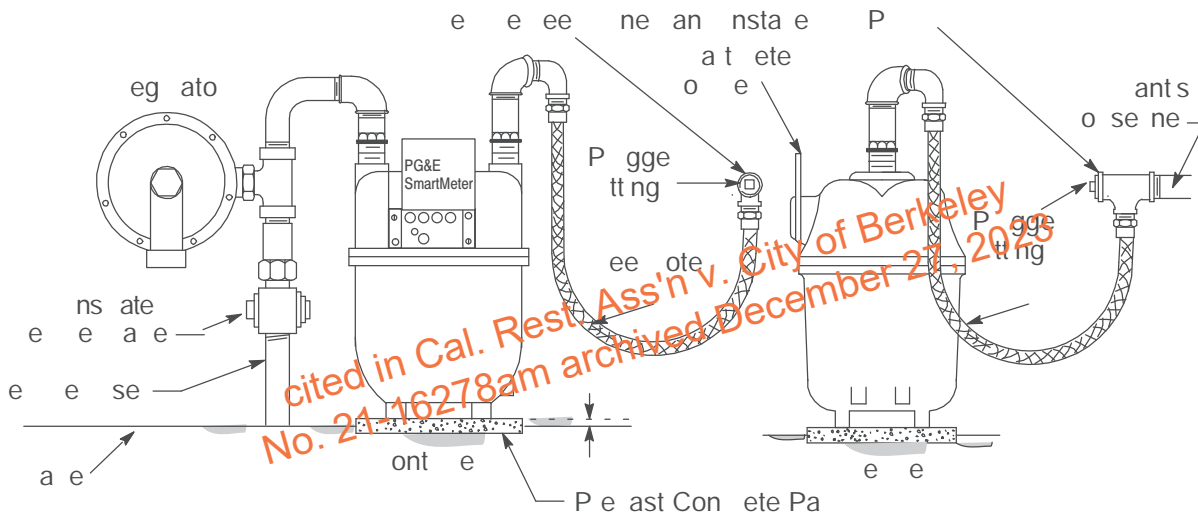


Figure 2-1  
Flex- ose Meter Set Residential and Small Commercial

notes in reference to Figure 2-1 .

1. hoses have a minimum bending radius ( ) based on the projected settlement of the ground and on the size of the hose.

## . acceptable meter locations

For new or remodeled buildings, *do not locate* gas meter sets in the following areas.

1. In curb meter boxes or vaults. (Only allowed as an option of last resort.)
2. In living quarters, closets, toilet rooms, or bathrooms.
  - . Under stairs inside or outside.
  - . In garages without properly vented meter cabinets.

Section 2, Gas Service

---

## 2. .2. (continued)

- . Behind fences. (This is not preferred, but on an exception basis may be allowed.) See Subsection 2. .2.A.1., “ required Access,” on Page 2-21.
- 6. On steep slopes.
  - . In areas where landscaping restricts access.
- 8. Within engine, boiler, heater, or electrical-equipment rooms.
- 9. Under display platforms or show windows in commercial buildings. (This includes any permanent, elevated display floors or platforms associated with the window where the purpose of the window is to present a display to the public.)
- 10. In contact with the soil, in a depression below general ground level, or where potentially corrosive materials are likely to contact the meter set.
- 11. In tradesman alleys (i.e., passageway in a building with a door at one end). Meters may be in a tradesman alley when in a vapor-proof cabinet that is vented to the outside and clear of sources of ignition.
- 12. In crawl spaces under buildings or decks.
- 1 . Near a driveway, drive-thru, or other traveled area.
- 1 . In a metallic cabinet, room, or location that blocks or interferes with the radio frequency signal transmissions that are necessary for PG&E to operate its SmartMeter™ Advanced Meter Reading system.
- 1 . In any location that does not provide the required clear and level work space. The height dimension is 6 feet, 6 inches of clearance above ground, 1 foot on each side of the meter facilities, and the depth dimension is 4 feet of clearance in front of the gas meter. See the figures in Subsection 2. .2.C., “Single Gas Meter Connection requirements,” below, for the different width dimensions.

NOTE All meter locations are subject to PG&E approval.

---

2. .2. (continued)

C Single Gas Meter Connection Requirements

The figures beginning on Page 2-28 illustrate typical meter-set dimensions and working clearance requirements based on the total diversified loads and stated delivery pressure.

**NOTE** The actual meter-set configuration, including the dimensions, may be different depending on field conditions and restrictions.

Consult with your local project coordinator for the exact meter location and houseline placement and orientation. Customer-installed equipment (e.g., earthquake valves) must be installed on customer houseline and cannot reduce the minimum riser-to-houseline dimension.

A commercial meter set may require the riser to be located farther away from the face of the building to accommodate the meter's installation.

Your local project coordinator can verify that risers and houselines are installed and meet all minimum clearance requirements before scheduling the meter set installation.

*cited in Cal. Rest. Ass'n v. City of Berkeley  
No. 21-16278am archived December 27, 2023*

Section 2, Gas Service

2. .2. (continued)

1. Figure 2-1 represents a typical gas meter kit with 0 through 0 scfh at inches C or 0 through 600 scfh at 2 psig. reverse sets are not allowed. The houseline must be to the right of the gas service riser.

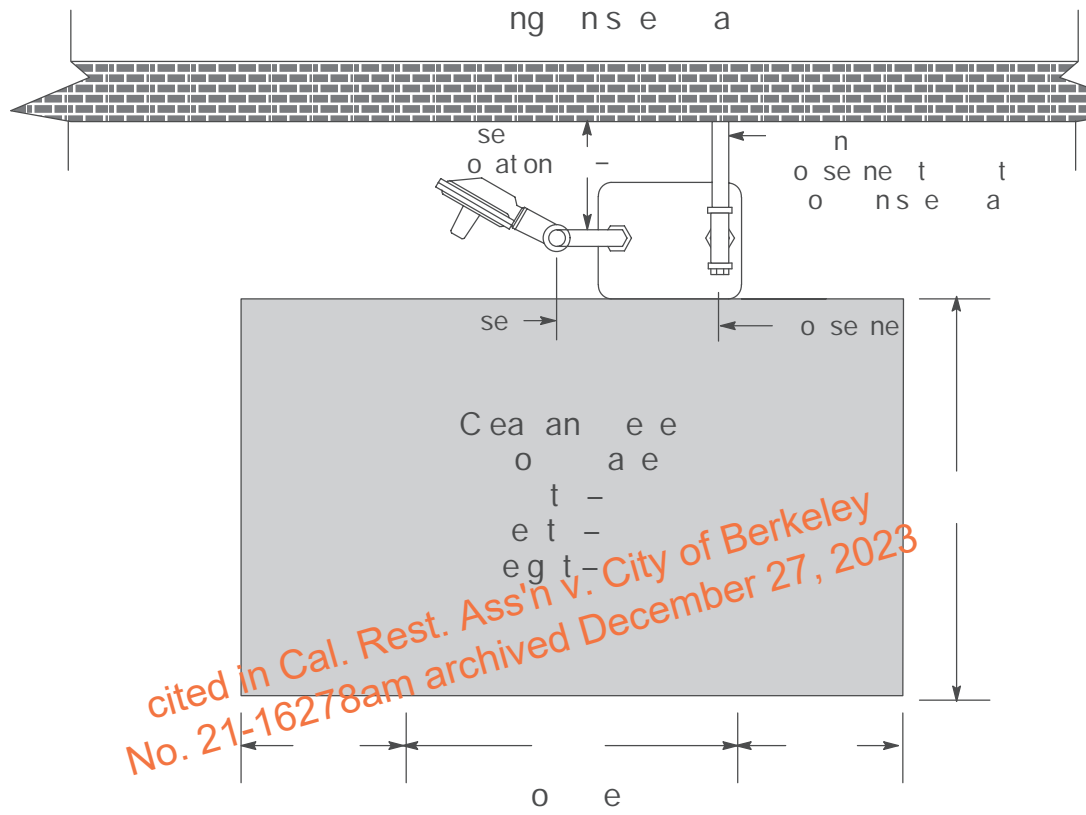


Figure 2-1  
Typical Residential Gas Meter Connection

2. .2. (continued)

2. Figure 2-1 represents a typical gas meter kit with 1 through 1,000 scfh at inches C or 601 through 2,000 scfh at 2 psig. Reverse sets are not allowed for 00 through 600 class meters (i.e., 00, 2, 60). The houseline must be to the right of the gas service riser.

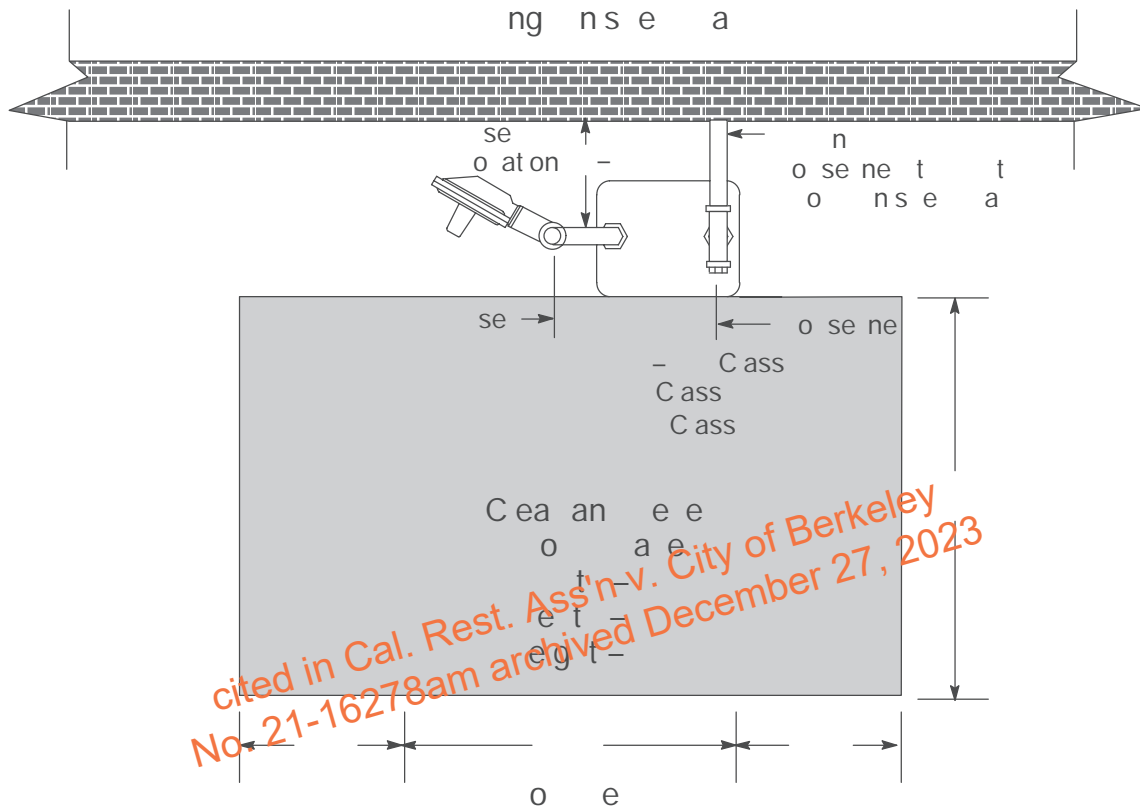


Figure 2-1  
Typical Gas Meter Connection for 00 to 1,000 Class Meters

Section 2, Gas Service

2. .2. (continued)

. Figure 2-16 represents a rotary gas meter with 1, 01 through ,000 scfh at an approved delivery pressure.

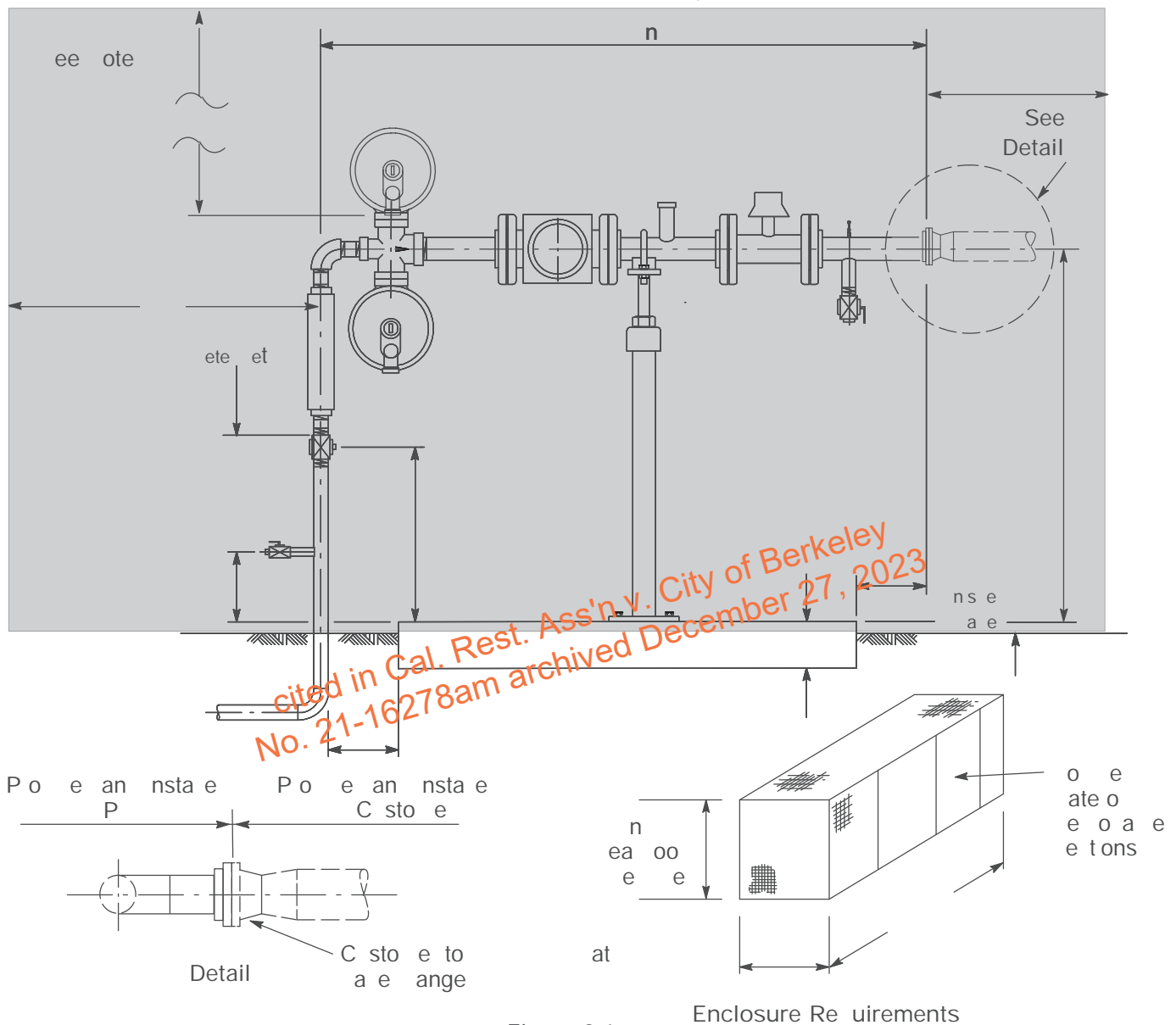


Figure 2-1  
Gas Meter Connection Using a 1 M or M Rotary Gas Meter

notes in reference to Figure 2-16.

1. Customers must provide a 0 inches x 6 inches x inches concrete pad with minimum rebar.
2. Customers must provide a 2-inch A SI 1 0 flat face flange to connect to PG&E facilities.
- . If the meter set is built next to a building wall, place the vertical leg of the riser and the houseline 20 inches from the wall. This ensures that the meter set components are built in a straight line.
- . The finished grade must be below the bury-line marking on the service riser.
- . PG&E's weld elbow is optional.
6. The regulator vent must not terminate near any sources of ignition or openings into the building. The riser must be a minimum of 6 inches from sources of ignition, from any openings into the building, or any wet facility. This clearance area extends 10 feet above the highest regulator vent, 6 inches below the lowest regulator vent, and 12 inches beyond the farthest PG&E meter-set equipment.

2. .2. (continued)

. Figure 2-1 represents a rotary gas meter with ,001 through ,000 scfh at an approved delivery pressure.

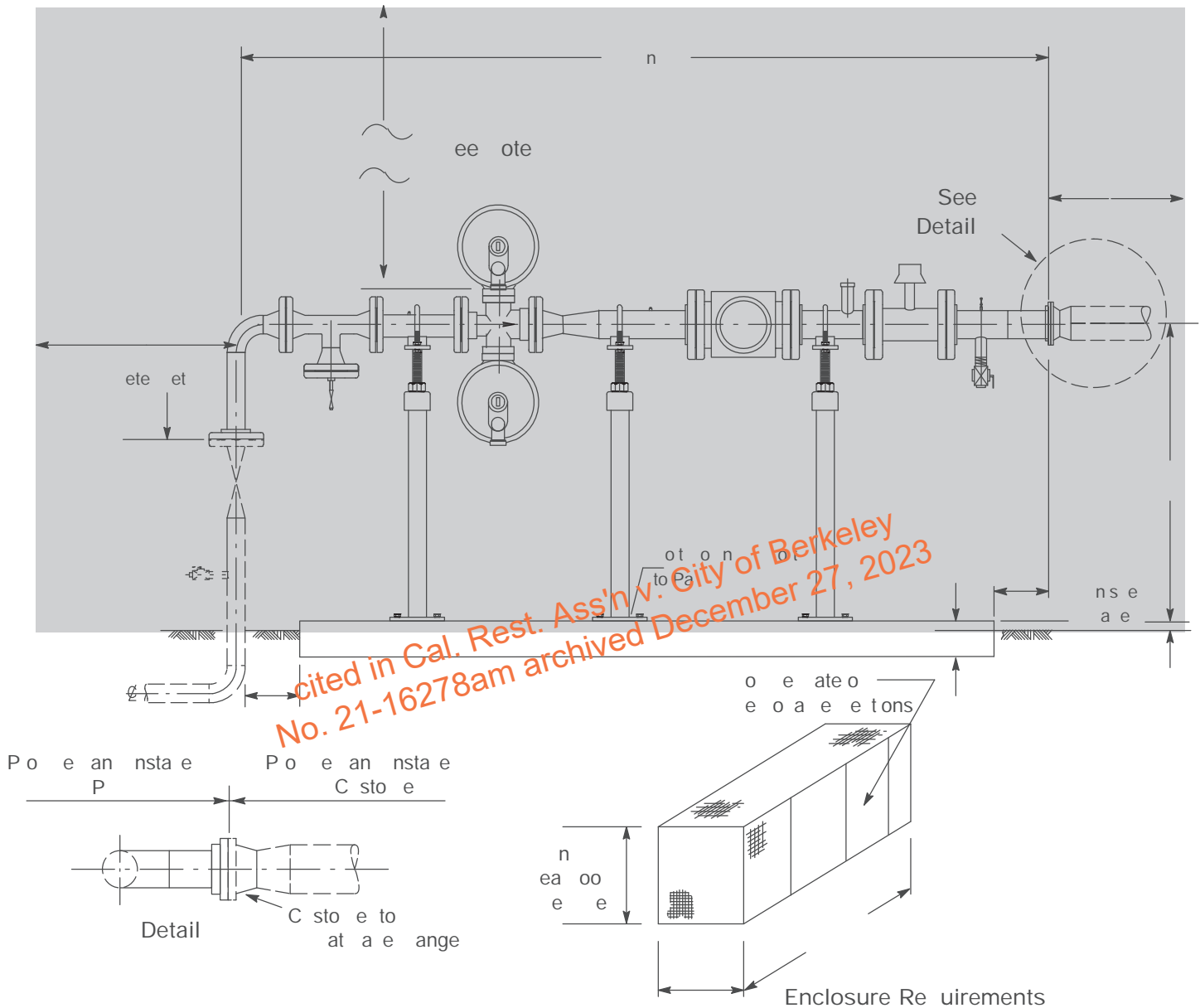


Figure 2-17

Gas Meter Connection Using a 1/2" M or 7/8" Rotary Gas Meter

Notes in reference to Figure 2-1 .

1. Customers must provide a 8-inches x 6-inches x 4-inches concrete pad with minimum #4 rebar.
2. Customers must provide a 2-inch A 151 10 flat-face flange to connect to PG&E facilities.
3. If the meter set is built next to a building wall, place the vertical leg of the riser and the houseline 20 inches away from the wall. This is to ensure the meter set components are built in a straight line.
4. The finished grade must be below the bury-line marking on the service riser.
5. PG&E's weld elbow is optional.
6. The regulator vent must not terminate near any sources of ignition or openings into the building. The riser must be a minimum distance of 6 inches from sources of ignition and openings into the building, or any wet facility. This clearance area extends 10 feet above the highest regulator vent, 6 inches below the lowest regulator vent, and 12 inches beyond the farthest PG&E meter-set equipment.



## Section 2, Gas Service

## 2. .2. (continued)

- Figure 2-18 represents a rotary gas meter with ,001 through 16,000 scfh at an approved delivery pressure.

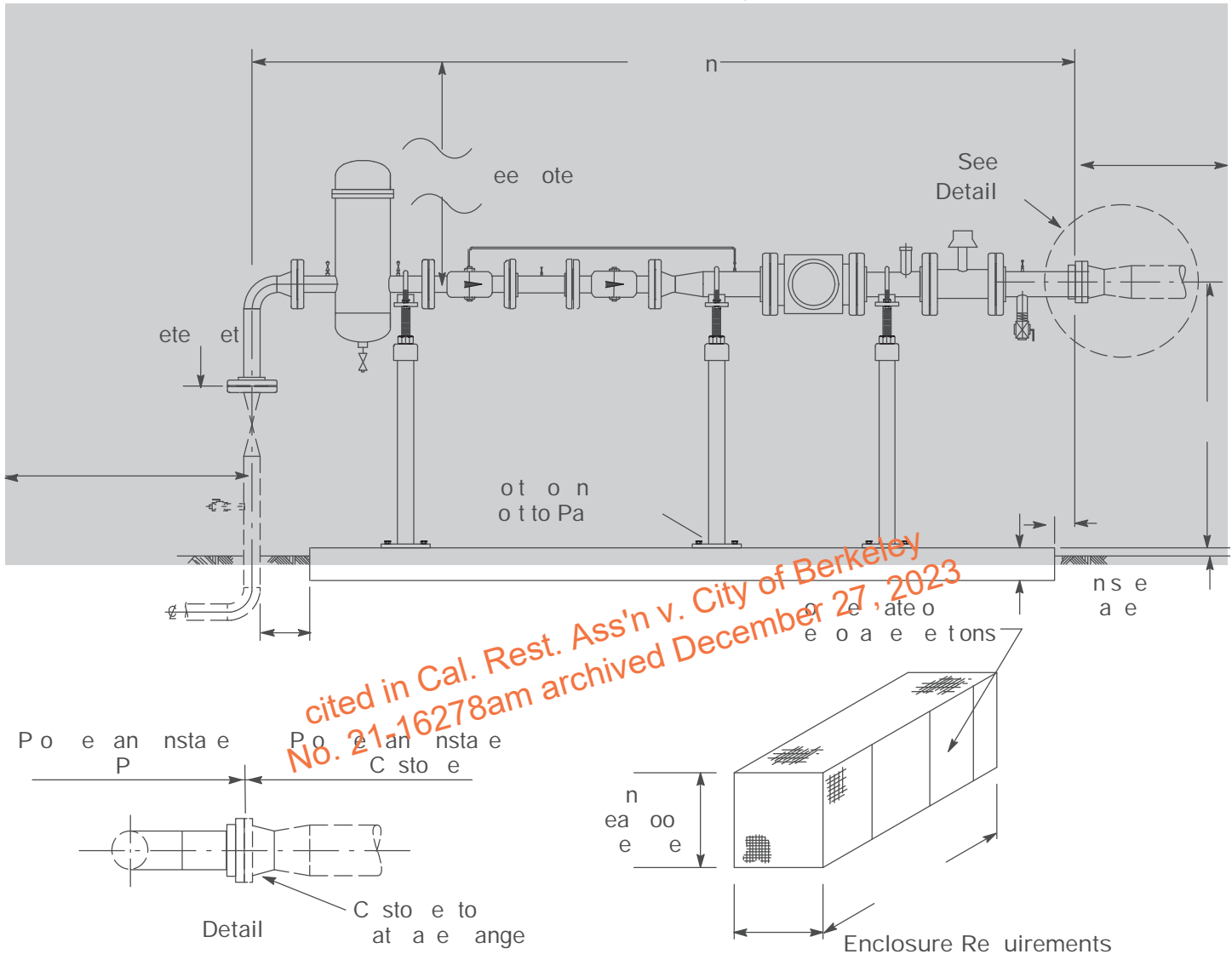


Figure 2-1  
Gas Meter Connection sing an 11M or 1 M Rotary Gas Meter

otes in reference to Figure 2-18.

- Customers must provide a 96-inch x 6-inch x -inch concrete pad with minimum rebar.
  - Customers must provide a -inch A SI 1 0 flat-face flange to connect to PG&E facilities.
- If the meter set is built next to a building wall, place the vertical leg of the riser and the house line 20-inches minimum away from the wall. This ensures the meter set components are built in a straight line.
  - The finished grade must be below the bury-line marking on the service riser.
  - PG&E's weld elbow is optional.
  - The regulator vent must not terminate near any sources of ignition or openings into the building. The riser must be a minimum distance of 6 inches from sources of ignition, openings into the building, or any wet facility. This clearance area extends 10 feet above the highest regulator vent, 6 inches below the lowest regulator vent, and 12 inches beyond the farthest PG&E meter-set equipment.

2. .2. (continued)

Contact your local project coordinator about possible locations for regulator vents.  
(The regulations for large, industrial meter sets can vary.)

D Minimum Meter Set Clearance Requirements

Figure 2-19, "Electric and Gas Meter Set Separation Dimensions and Clearances," below Figure 2-20, "Gas Meter Set Clearance from Building Openings," on Page 2- and Figure 2-21, "Gas Regulator Set Clearance Requirement from Sources of Ignition," on Page 2- 6, all represent various metering facilities' clearance requirements. If applicants install enclosures on their premises, the enclosures must meet the clearances provided in these illustrations.

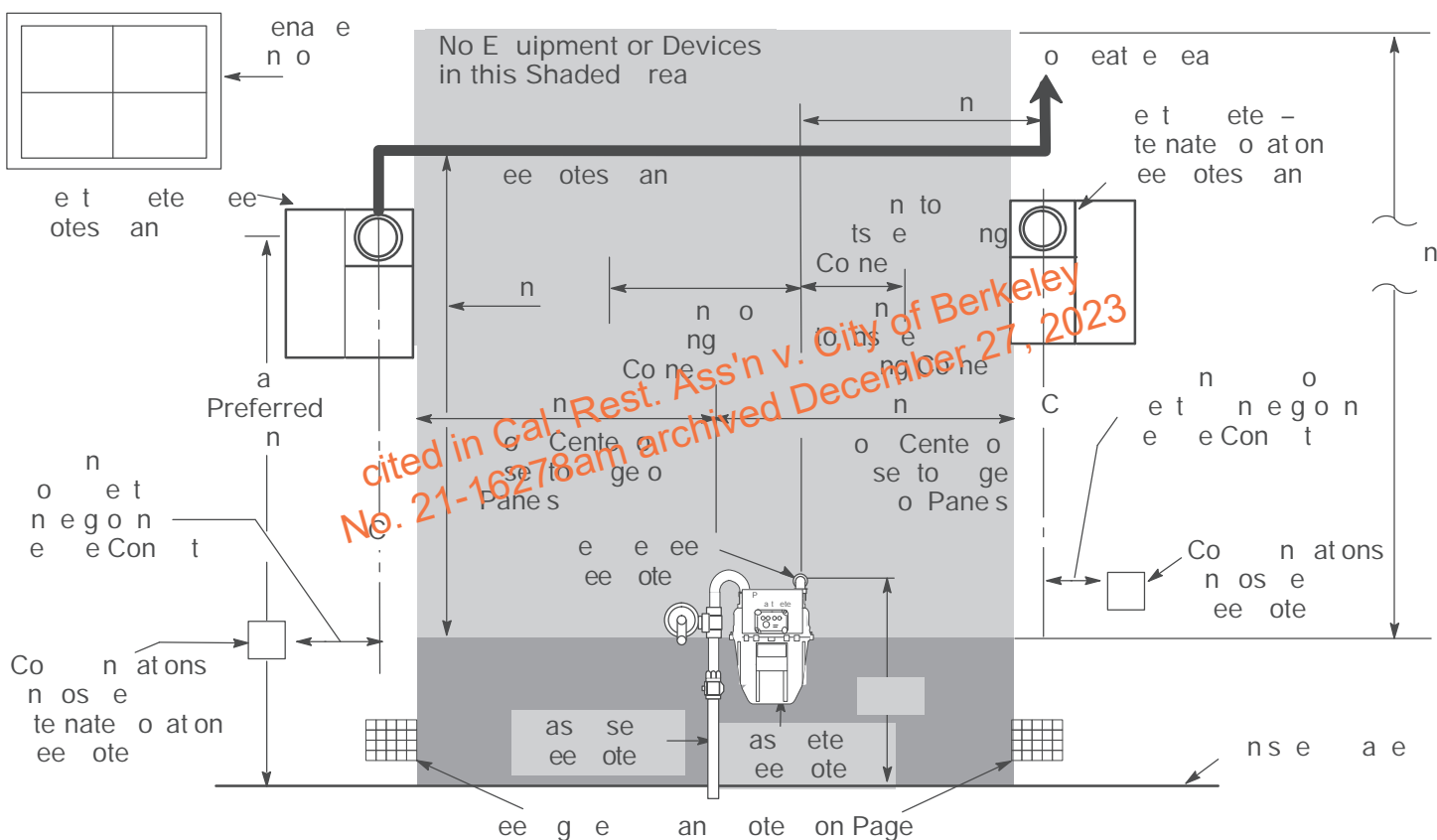


Figure 2-1  
Electric and Gas Meter Set Separation Dimensions and Clearances

notes in reference to Figure 2-19.

1. Electric meter panel locations are subject to utility approval and must comply with the applicable code requirements. PG&E does not have specific requirements for the distance from the electric panel to the outside building corner. See [Section](#) , "Electric Metering: General," for properly locating the electric meters. See [Subsection](#) . . . . "Working Space," on Page -1 , for electric meter working space.

Notes continued on the next page

2. .2. (continued)

otes in eference to otes in reference to Figure 2-19 (continued).

- 2. Applicants must *not* install any electrical devices or equipment, including wires, cables, metering enclosures, telecommunication enclosures, bond wires, clamps, or ground rods within the shaded area around the gas meter. The 6-inch distance can be reduced to 18 inches for electrical devices or equipment certified for EC Class I, Division 2 locations.
- . A solid and continuous conduit without couplings, joints, or connections is allowed to run completely through the shaded area at 6 feet or higher above the gas meter regulator vent.
- . Place the gas service riser 6 inches to 9 inches from the finished wall. The completed customer houseline at the service delivery point must extend a minimum of 6 inches from the finished wall where the meter is to be set and must be 26 inches above the finished grade. See Figure 2-1 on Page 2-28, Figure 2-1 on Page 2-29, and Subsection 2. . on Page 2- 9.
- . The minimum dimensions and clearances in Figure 2-19 are good for gas meters up to the 1,000 class. See Figure 2-1 and Figure 2-1 on Pages 2-28 and 2-29 for illustrations of clear and level work space in front of the gas meter.

cited in Cal. Rest. Ass'n v. City of Berkeley  
No. 21-16278am archived December 27, 2023

## 2. .2. (continued)

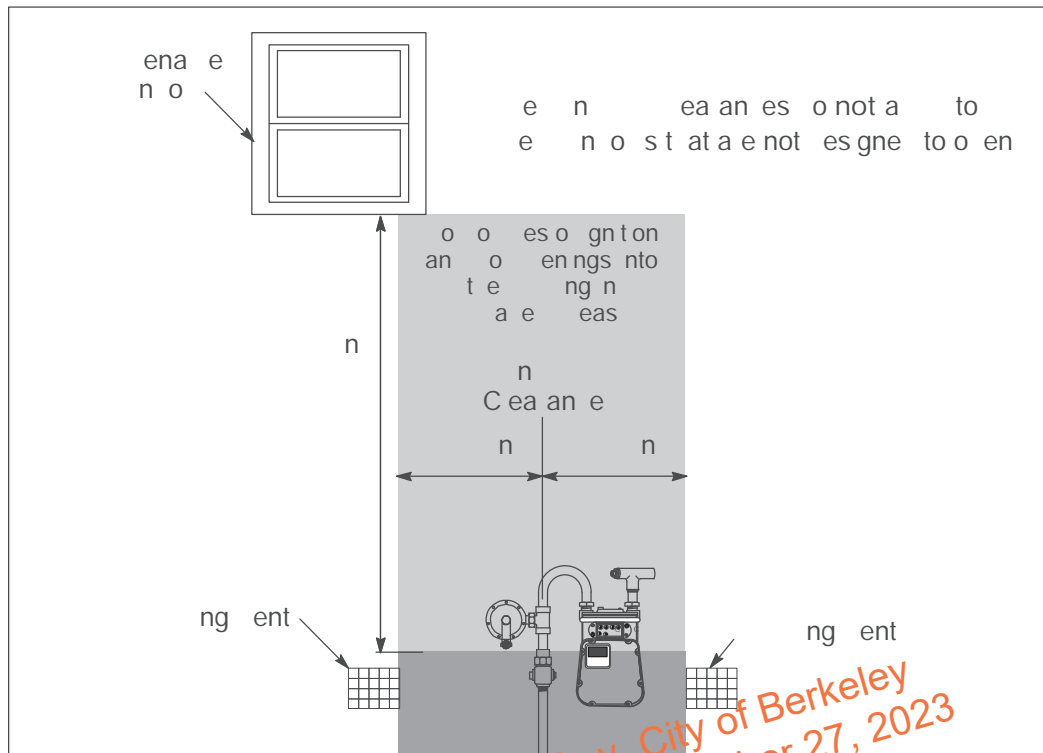


Figure 2-20  
Gas Meter Set Clearance From Building Openings

notes in reference to Figure 2-20.

1. Do *not* place gas regulator vents under display platforms or show windows in commercial buildings. This includes any permanent, elevated display floors or platforms associated with the window, where the purpose of the window is to present a display to the public.
2. Do *not* place gas regulator vents under building overhangs where the overhang is likely to direct venting gas to a building opening.
  - . The building vent openings, sources of ignition, and above-ground water sources must be a minimum of 6 inches away from the riser.
  - . Applicants must not install water spigots, lines, gutter systems, or other water sources within 6 inches of the gas riser or electric facilities.
  - . For a large meter set or multimeter manifold, the minimum separation requirement for sources of ignition, opening to buildings or sources of above-ground water, extend 12 inches beyond the farthest PG&E metering facilities and 10 feet above the highest regulator vent.

2. .2. (continued)

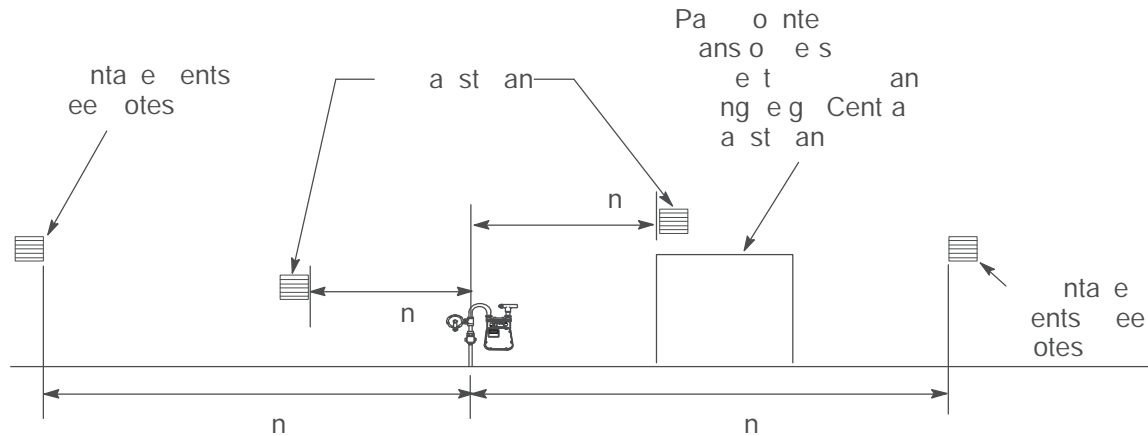


Figure 2-21  
Gas Regulator Set Clearance Requirement from Air-Intake and Exhaust Fans

notes in reference to Figure 2-21.

1. An 8-foot minimum horizontal and 10-foot minimum vertical clearance is required from the gas service riser to air-intake vents.
2. For a large meter set or multimeter manifold, this clearance requirement will extend 8 feet beyond the farthest PG&E meter equipment.

Electric Panel Replacements and Conduit Connections to Existing Electric Panels, 00 mps and less, within the Gas Clearance Area

Electric panel upgrades, "like-for-like" panel replacements, and new electric conduit connections to existing electric meter panels may be allowed for an existing electric meter panel that resides within the gas clearance area as shown in Figure 2-19, "Electric and Gas Meter Set Separation Dimensions and Clearances, on Page 2- , if all the following requirements are met

1. The electric panel and electric conduit and equipment must not reside within the 6-inch radius from the gas regulator vent opening.
2. The electric panel must not reside within 12 inches on either side of PG&E gas facilities and 10 feet above the regulator vent opening as shown in Figure 2-22, "Clearance Requirements for an Existing Electric Meter/Panel," on Page 2- 8. If any portion of the existing electric panel resides within this area, the electric panel must be relocated outside all clearance areas shown in Figure 2-22 before the panel is replaced and any conduit connection is made.
3. Additional electric equipment/devices must not be installed within the clearance areas shown in Figure 2-22.

2. .2. (continued)

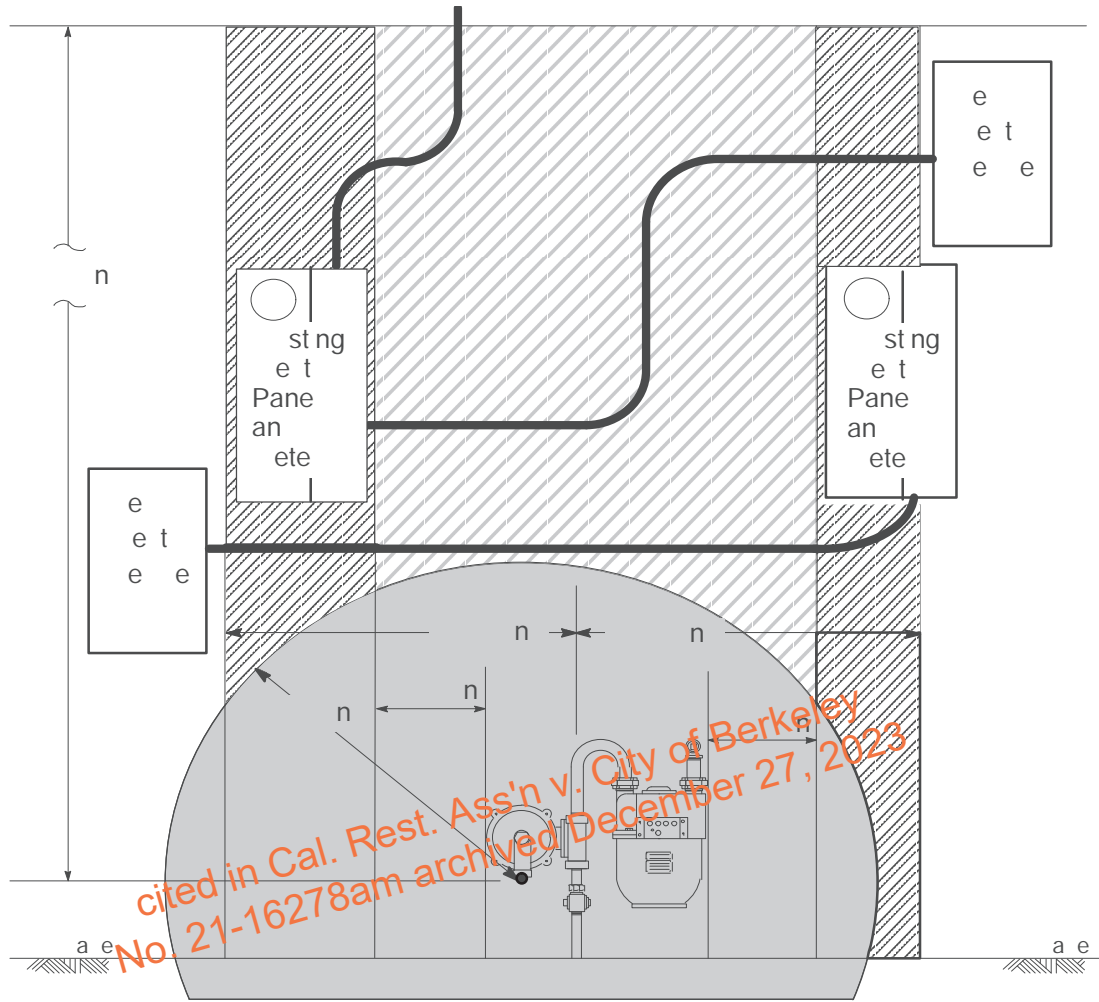
**E ception** A continuous metallic conduit with no couplings or joints can run completely through and terminate/connect outside of the 6-inch radial clearance from the gas regulator vent opening.

- . All minimum clear and level working space requirements for the electric meter panel and gas meter set must be met.

*cited in Cal. Rest. Ass'n v. City of Berkeley  
No. 21-16278am archived December 27, 2023*

Section 2, Gas Service

2. .2. (continued)



LEGEND

- Existing Electric Meter/Panel
- Connections to Gas Meter/Panel
- ▨ Existing Electric Meter/Panel
- ▩ Existing Electric Meter/Panel

Figure 2-22  
Clearance Requirements for an Existing Electric Meter/Panel

notes in reference to Figure 2-22:

1. This includes electric meters and panels in cabinets.
2. Junction boxes or other electrical enclosures must not be installed to replace the existing electric meter panel.

## 2. .2. (continued)

## F Multimeter Manifolds

Specific requirements in this subsection apply to particular types of premises (e.g., multifamily, apartment, and commercial buildings) where multiple meters are installed at a single location using the manifold configuration. These manifold connection requirements are additions to the meter-set requirements for single gas meter sets.

PG&E limits gas meter manifold configurations to one-tier or two-tier meter manifolds not exceeding 60 inches high. These manifolds are measured from the final, level, standing surface to the top of the manifold.

**NOTE** Applicants must provide their PG&E project coordinator with a written justification for approval when requesting a three-tiered manifold or a manifold greater than 60 inches high.

PG&E will assess the applicant's site and conditions for gas service and metering installations before approving an installation site. For manifolds requiring support brackets, the applicant must provide a wall surface with adequate structural support to use  $\frac{1}{4}$ -inch x  $1\frac{1}{2}$ -inch lag screws to secure all brackets.

Refer to [Gas Design Standard -1](#), located in [Appendix C](#), for additional information.

cited in Cal. Rest. Ass'n v. City of Berkeley  
No. 21-16278am archived December 27, 2023



Section 2, Gas Service

2. .2. (continued)

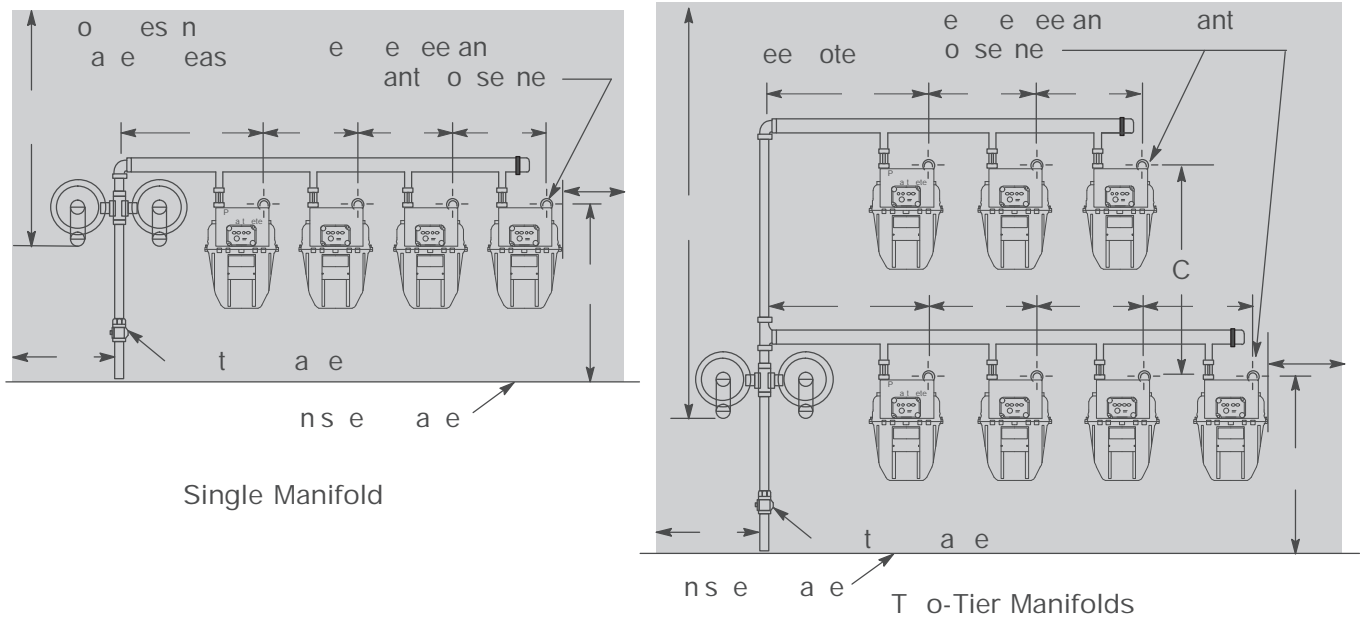


Figure 2-2  
Dimensions for Typical, Residential, Multimeter Installations

notes in reference to Figure 2-2

1. The applicant's houselines must be stubbed out 6 inches to 6 inches from the finished wall at the locations shown.
  2. The applicant must clearly mark each houseline. See Subsection 2. .2.G.I., "Meter-Set Requirements for Marking Houselines," on Page 2-1.
- . Gas meter manifolds may be built in a right-to-left configuration (reverse) when approved in advance.
  - . Applicants must *not* install any electrical devices or equipment, including wires, cables, metering enclosures, telecommunication enclosures, *bond wires claps or rods* within 6 inches horizontally from the riser and 12 inches from the farthest edge of PG&E facilities and 10 feet above the regulator vent.
  - . Applicants may need to install the riser farther away from the building to accommodate the manifold installation. Consult your local project coordinator for site-specific details.

2. .2. (continued)

Table 2-2 Dimensions to Figure 2-2

Dimension	Installation	Comments
	Installation of a gas meter in a recessed alcove.	Provide a recessed alcove for the meter.
	Installation of a gas meter in a recessed alcove.	-
C	Installation of a gas meter in a recessed alcove.	Contact the gas utility for specific requirements.
	Installation of a gas meter in a recessed alcove.	Provide a recessed alcove for the meter.
	Installation of a gas meter in a recessed alcove.	Provide a recessed alcove for the meter.
	Installation of a gas meter in a recessed alcove.	Provide a recessed alcove for the meter.

Requirements for Alcoves, Enclosures, Gas-Meter Cabinets, Closets, and Gas-Meter Rooms

1 Alcoves

An alcove is an exterior space that is recessed into a building or wall. The alcove's width can vary depending on the meter set. PG&E provides final dimensions after confirming the meter size. Please consult your local project coordinator for guidance.

For single-diaphragm meters, applicants must use the area dimensions shaded in Figure 2-14 on Page 2-27 and Figure 2-15 on Page 2-28 (depth not to exceed 36 inches).

For single-rotary meters, use the area dimensions shaded in Figure 2-16 on Page 2-29, Figure 2-17 on Page 2-30, and Figure 2-18 on Page 2-31 (do not exceed 36 inches deep and 8 feet high).

A manifold located in an alcove may require a custom design depending on the configuration.

**Gates are not a preferred option** and will be approved only on a case-by-case basis. If a gate is proposed in front of the alcove, it must have a minimum 50% open area.

The alcove must not have openings into the building, sources of ignition, or other facilities (e.g., wiring, water downspouts, or foreign pipes).

Contact your local PG&E project coordinator for more information.

2. .2. (continued)

2 Enclosures

Gas Meter Set Enclosures

a. Typical Enclosure Details

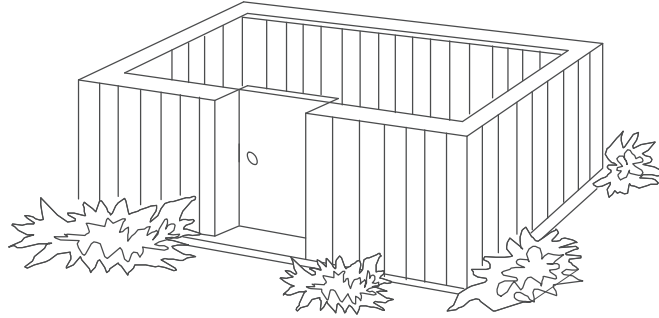


Figure 2-2  
Typical Detached Enclosure

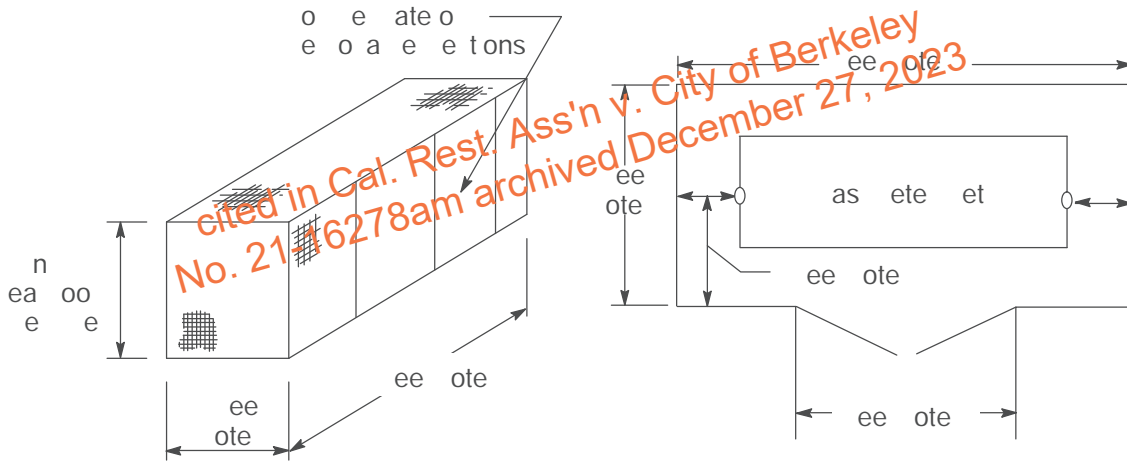


Figure 2-2  
Typical Enclosure Dimensions

notes in reference to Figure 2-2 and Figure 2-2 .

1. The enclosure's length and width will vary depending on the meter set. Contact your local PG&E project coordinators for more information.
2. Approved enclosure wall materials include, but are not limited to, concrete block, wood, perforated or expanded metal, or metal chain-link fencing.
3. PG&E determines if the enclosure requires a wire mesh cover. If a mesh cover is required, it must have a minimum 50% open area.
4. All distances provided in Figure 2-2 are minimums. After PG&E confirms the meter size, final dimensions will be provided.
5. Trucks must be able to access large meter installations. Please contact your local PG&E project coordinator before designing locations for gas meters.
6. Additional meter protection may be required. Protection posts can be incorporated into an enclosure design.

## 2. .2. (continued)

**b. Special Requirements for Gas Meters Serving Schools or Other Buildings where Children Congregate**

The following requirements apply to schools or other buildings where children congregate.

- Locate the gas meter enclosure adjacent to the property line or away from buildings in a wire cage enclosure or other suitable protective enclosure.
- PG&E requires an overhead wire cover to prevent any debris or other material from falling inside the enclosure. The applicant must ensure that PG&E is able to secure the enclosure with a PG&E lock.
- It is the applicant's responsibility to provide the enclosure and concrete pad for the gas meter set. PG&E must approve the final design and size of the enclosure.

**General Requirements for Meter Cabinets**

Gas cabinets are not preferred and require PG&E's approval in advance of construction. Applicants must ensure that all vent openings, louvers, and/or viewing windows are installed correctly. Also, applicants must ensure that the cabinets open to the outside and are readily accessible to PG&E at all times.

When approved by PG&E, the gas meter size represented in Figure 2-1 , "Typical Residential Gas Meter Connection," located on Page 2-28, can be installed in a cabinet.

On a case-by-case basis, PG&E may allow an applicant to install a gas meter the size of the one illustrated in Figure 2-1 , "Typical Gas Meter Connection for 00 to 1,000 Class Meter," located on Page 2-29, in a cabinet.

A gas estimator must provide the cabinet spacing and size requirements, which then must be approved by a Field Service Manager.

**a. Specific Requirements for a Single Gas Meter Cabinet**

PG&E determines the minimum cabinet size allowed for an applicant's specific type of meter and provide the applicant with those dimensions. PG&E bases cabinet requirements not only on the size of the meter currently required, but also on the location and accessibility of the meter. See [Gas Design Standard - 1](#), located in [Appendix C](#), when determining the specifications for single gas meter cabinets.

2. .2. (continued)

b. Specifications for a Recessed, Individual Meter Cabinet

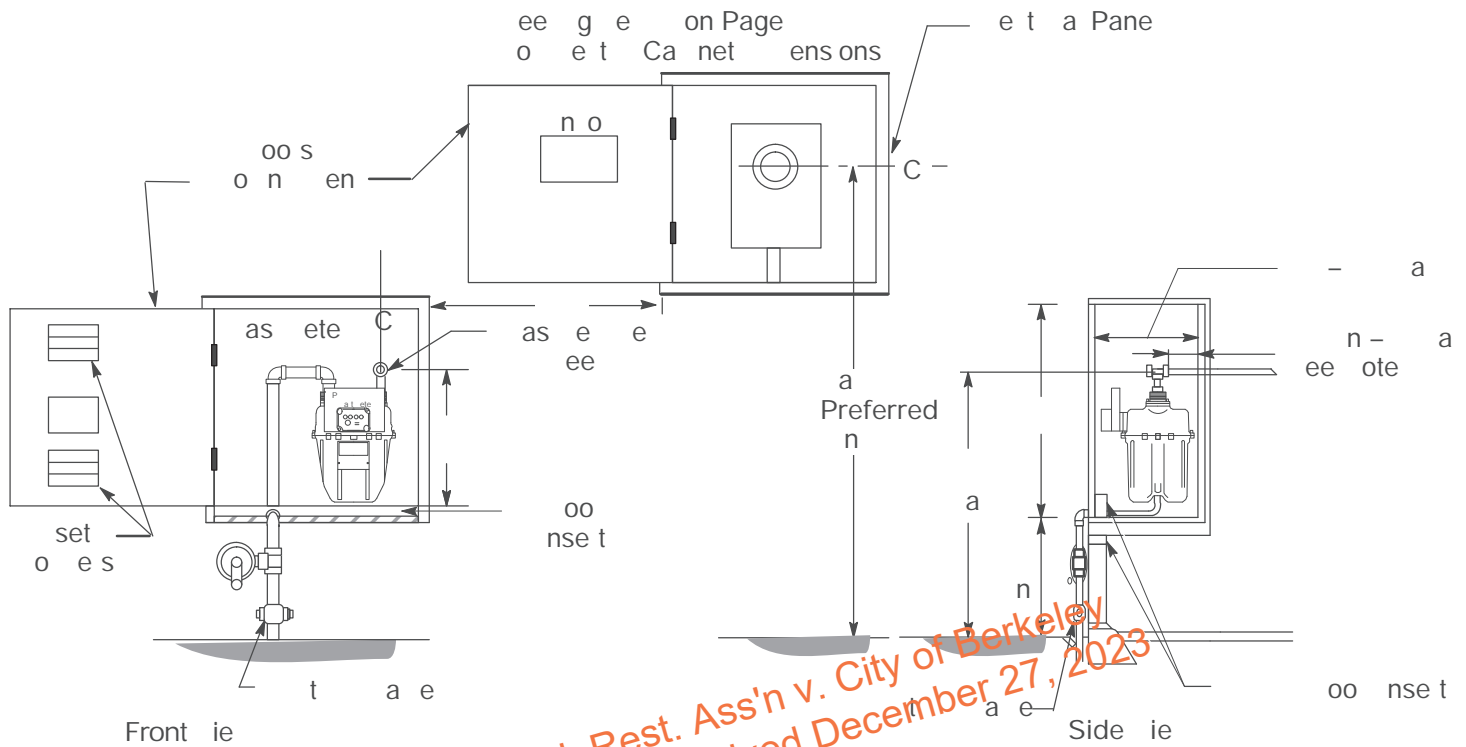


Figure 2-2  
Recessed, Individual Meter Cabinet for Gas and Electric Meter Installations

Notes in reference to Figure 2-26.

1. Meter cabinets are not a preferred method of installation. Meter cabinets, with the exception of Class 2 0 meter installations, require approval from the local Field Services Manager before construction begins. When approved, they must comply with the requirements in this section.
  2. Regulators will be installed on the outside of the cabinet. Additional space is required for larger regulators and dual-head regulators. The local Field Services Manager may approve the regulators to be installed in a cabinet. Regulators installed in a cabinet require the vents to be piped out as described in [Gas Design Standard -9](#), "Piping Details: Regulator Vent Lines Above Ground."
- . See Subsection 2. .1., "Service Delivery Point for the Gas Supply," on Page 2- 0. The houseline at the service delivery point also must be reinforced so that it can provide support for the meter set piping. The pipe must be rigid, a minimum of 1/2 inch, and have male National Pipe Thread ( NPT) threads.
  - . The houseline must extend a minimum of 6 inches and a maximum of 6 inches into the gas meter cabinet measured from the finished wall. The houseline must be 26 inches above the bottom of the meter cabinet.
  - . Applicants must provide louvered, non-metallic doors. Each door must open at least 90°.
  - 6. The gas meter cabinet must have a gas-tight seal and be vapor proof from the building. Construction material and sealing requirements for the cabinet are described in [Gas Design Standard - 1](#), located in [Appendix C](#), and also apply to Figure 2-26.

Notes continued on the next page

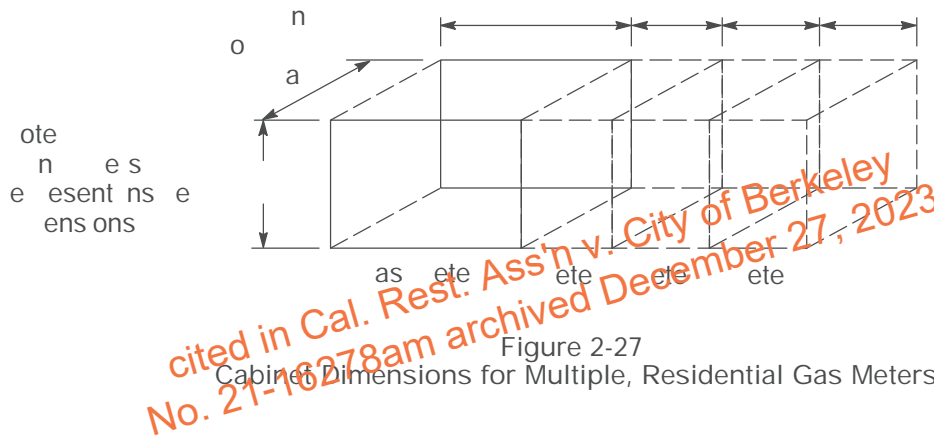
## 2. .2. (continued)

notes in reference to Figure 2-26 (continued).

- . Applicants must ensure that gas meters installed in cabinets comply with the requirements of the inspection authority having jurisdiction.
- 8. Do *not* place electric meter panels, equipment or devices, conduit or wiring, enclosures or electrical connections water services, faucets, downspouts, or other wet utilities within 6 inches of the gas riser including for services such as cable television or telecommunications.

Requirements for multiple, residential, gas meter cabinets are shown in Figure 2-27, "Cabinet Dimensions for Multiple, Residential Gas Meters," and include dimensions and details.

Gas meter manifolds may be built in a right-to-left (i.e., reverse) configuration when approved in advance.



### Gas-Meter Closets

Gas meter closets will be furnished and installed by the applicant and have a depth of 18 inches minimum and 6 inches maximum without exception. Doors must be non-metallic and fully louvered. Doors must open at least 90° and have a clear opening height of 6 feet, 8 inches tall.

The inside of the closet must be made of nonflammable material and have a minimum 1-hour fire rating. All joints and penetrations must be sealed to prevent gas from migrating into the structure.

Foreign pipes are not allowed inside the closet with the exception of fire sprinkler heads. Lighting, wiring, conduits, junction boxes, or inspection panels of any kind are not allowed inside the closet. Bonding or grounding wires on the customer's houselines are not allowed inside the closet.

The ceiling must have a 1:12 slope. The ceiling must slope up toward the door frame with a maximum 6 inches measured from the door opening to the finished ceiling. The inside width of the closet cannot exceed 8 inches beyond either side of the door frame.

## 2. .2. (continued)

refer to Figure 2-2 on Page 2- 0 for manifold spacing to determine the size of closet required for the desired number of meters. The meters and manifold must fit within the opening of the closet doors with the exception of the tie-in piece from the outside riser. The riser and regulator will be installed outside of the closet.

The applicant provides a penetration through the wall into the closet. The pipe penetration from outside to inside must not conceal the pipe. It must be clearly visible for inspection. Contact your local project coordinator for the exact size and location of the required penetration.

The doors must have signs identifying “Gas Meters.” If the doors have locks, the applicant must install a lock box, provided by PG&E, near the closet in a location that is acceptable to PG&E and contains the access key provided by the applicant.

The closet cannot be used for storage of any kind. Only PG&E gas meters and metering appurtenances are allowed inside the closet.

## Specific Requirements for Gas Meter Rooms

refer to [Gas Design Standard -10](#), located in [Appendix C](#), for specific requirements about gas meter rooms.

## Meter Protection Requirements

Applicants must protect meter sets in locations that are subject to damage from vehicular traffic. PG&E determines when such protection is required. refer to [Gas Design Standard -9](#), located in [Appendix C](#).

Applicants must protect all gas meter sets located in the following areas.

1. within 3 feet of:
  - Single-family, residential driveways or parking areas (including garage areas)
  - Commercial refuse container locations
  - Thoroughfares
  - Paved areas with curbs
2. within 8 feet of:
  - Multifamily, commercial, or industrial driveways or parking areas (see the “Exception” below)
  - Loading docks
  - Freight-handling areas
  - Thoroughfares
  - Paved areas without curbs

## 2. .2. (continued)

**EXCEPTION** Physical protection is *not* required for meter sets located within 8 feet of multifamily, commercial, or industrial driveways or parking areas if the meter set is located feet behind a barrier that is adjacent to the area and if PG&E finds the barrier to be acceptable.

- . Within an area that has, in PG&E's judgement, an unusually high risk of vehicular damage, the applicant must install a system of barrier posts that meet PG&E's specifications. Consult your local project coordinator for specific requirements.

## I Meter-Set Requirements for Marking Houselines

Applicants must ensure that the following rules for marking houselines are followed.

1. Establish service at one Service Delivery Point, through one meter, and at one voltage class or pressure.
2. PG&E requires that lines are marked by attaching an embossed, durable, metal or plastic tag to each houseline. PG&E must approve of the tag.
  - . Markings *must* be legible and specific.
  - . Marking information must include an authorized apartment or street number and a use or location designation.
  - . The houseline must be permanently, clearly, and prominently marked *at the point of the service connection* (i.e., service delivery point).

**NOTE** PG&E will *not* install meters unless the permanent address, the location, or, when applicable, the area being served is marked at each meter location.

6. When gas meters are installed in interior locations or rooms, the words "Gas Meters" must be placed on the room or location access doors to allow PG&E employees to find the meters easily.

## Meter Sets Requiring Electric Circuits for Communication

PG&E prefers to install, own, and maintain cellular equipment with a customer-provided, dedicated, electrical circuit for gas meter sets with electronic equipment that require communication. When applicants have an estimated average use of 10,000 therms per month or more, certain rate schedules, Automated Meter Reading (AMR), noncore accounts, or other nonstandard gas metering conditions, then the customer must provide an electrical circuit.



## 2. .2. (continued)

When installing customer-provided, dedicated electrical circuits with no less than 1 amp and 120 volt alternating current (ac) to a lockable disconnect switch within feet of a gas meter that meets or exceeds National Electric Code (NEC) Class I, Division 2, Group D hazardous area requirements, all above-ground wiring must be placed in threaded, rigid-steel or intermediate-steel conduit with an above-ground riser conduit seal to prevent gas from migrating to areas classified as nonhazardous.

PG&E will inform the customer that if conditions change in the future, a phone line may be required. If cell service is not available or acceptable to PG&E, the applicant may be required to install, own, and maintain a nominal, 1-inch diameter conduit and a telephone cable to within feet of the meter.

## Gas Pulse Metering

Refer to [Gas Standard -6 .1, "Volume Pulse Output Connection for Gas Meters,"](#) located in [Appendix C](#), for specific requirements about gas pulse metering.

Additional Meter-Set Requirements of SmartMeter™ Module Location Requirements.

PG&E's SmartMeter Advanced Meter Reading system uses radio frequency (RF) technology to transmit gas meter reads automatically. This allows PG&E's customers to monitor their daily energy use.

SmartMeter customers have additional location requirements specific to the meters necessary for PG&E to operate its SmartMeter Advanced Meter Reading system. Applicants must be aware of the following requirements to ensure that the SmartMeter Advanced Meter Reading system can operate properly.

1. Do not locate the meters in any room, cabinet, enclosure, or configuration that blocks or interferes with the radio frequency signal transmissions. An example of such a prohibited enclosure is a metallic cabinet.
2. Do not locate the meters in close proximity to (i.e., 6 inches or less) any metallic object that could block or interfere with the radio frequency signal transmission.
3. Do not install gas meters within feet of building walls and ceilings if they are made from a significant amount of metal or metal reinforcements.

## 2. .2. (continued)

- . Most SmartMeter gas modules are installed directly on a gas meter. If a gas meter is installed in a cabinet, meter room, below grade, basement garage, or other location where communication problems may exist, PG&E may install a module in a remote location away from the gas meter to ensure proper radio frequency transmissions. The equipment may be installed on nearby gas piping, a customer-owned building wall/ceiling, or an outside location. The equipment may need to be attached to the structure or wall to route the wiring.

## M SmartMeter Gas Network Utility Closet Requirements for Indoor Meter Rooms

This section provides SmartMeter infrastructure installation and construction requirements for customers designing indoor gas meter rooms. It addresses below-grade and multiple above-grade meter room installations such as those that may exist in urban, high-rise environments to ensure PG&E's SmartMeter F network is established for these customers. These provisions are required for commercial and/or residential, with single or multiple indoor meter rooms to ensure SmartMeter gas network communication access and performance.

A separate SmartMeter gas network utility closet must be constructed for each indoor meter room directly adjacent (with a common or shared wall) to the natural gas meter room. In addition, two 1-1/2 inch conduits would be required: one from the SmartMeter gas network utility closet to the outside of the building and one from the SmartMeter gas network utility closet to the indoor gas meter room. See the requirements listed in [Gas Design Standard -16](#), located in [Appendix C](#),

## 2 Applicant-Owned and Installed Gas Service Piping (e.g., Houseline), Valves, and Automatic Shut-Off Devices

The applicant is responsible for maintaining the applicant-installed and owned gas service piping, valves, automatic shut-off devices (e.g., earthquake valves), or other piping components on any premises or in any building. These applicant-owned components must be installed downstream of (i.e., after) the gas supply service delivery point. PG&E reserves the right to suspend service until applicant-owned equipment is removed from PG&E meter-set assemblies.

Applicants must ensure that after their equipment is installed, the equipment *does not* obstruct the operation or serviceability of PG&E's piping, metering, and pressure-regulating equipment.

The houseline at the service delivery point typically is located after the PG&E service tee for residential services. Reinforce the houseline so that it provides support for the meter-set piping. For residential service, the houseline stub-out must be a minimum of 1/2-inch steel rigid pipe with male PT threads. Larger gas loads or commercial meter sets may require a flanged connection.

## 2 1 Service Delivery Point for the Gas Supply

The service delivery point for the gas supply is the point where PG&E's facilities connect to the applicant's house pipe (i.e., houseline). Figure 2-1 on Page 2-6 illustrates a typical service delivery point.

For *residential* and *small commercial* meter sets, the service delivery point is the point where the male threads of the applicant's houseline connect to the female threads of PG&E's gas service tee fitting.

Some *commercial* installations and *industrial* installations *do not* have service tees installed. For these installations, the gas supply service delivery point is located after the gas meter, gas pressure regulator, or regulation equipment. Specifically, it is the point where the gas service bypass reconnects with the gas service outlet piping.

Typically, the gas supply service delivery point is either the first weld or fitting after the PG&E-installed bypass valve downstream of (i.e., after) the gas meter. See Subsection A in Figure 2-16 through Figure 2-18 on Page 2- 0 through Page 2- 2.

PG&E *does not* allow applicants to access the pipe fitting's plug. Only PG&E employees are authorized to access the plug when they perform service and maintenance.

Applicants *must not* connect or install non-PG&E components to any portion of the PG&E gas meter set upstream of (i.e., before) the service delivery point.

Applicants must provide a securely supported gas houseline connection to PG&E piping either by bracing or by reinforcing the houselines that extend from finished walls. Do *not* connect flexible houseline directly to PG&E piping. (Exceptions include subsidence areas, mobile home parks, and manufactured homes as described in [Gas Design Standard -12.](#), "[Mobile Home/Manufactured Home Meter Set Installation.](#)" and [Gas Design Standard - 8.](#))

When applicants require a gas supply for multiple gas meter installations that are supplied by a manifold, PG&E will install gas service tees downstream of (i.e., after) each gas meter. PG&E will install these service tees to each location where the utility gas service pipe connects to the applicant's houseline at the service tee.

2. .1. (continued)

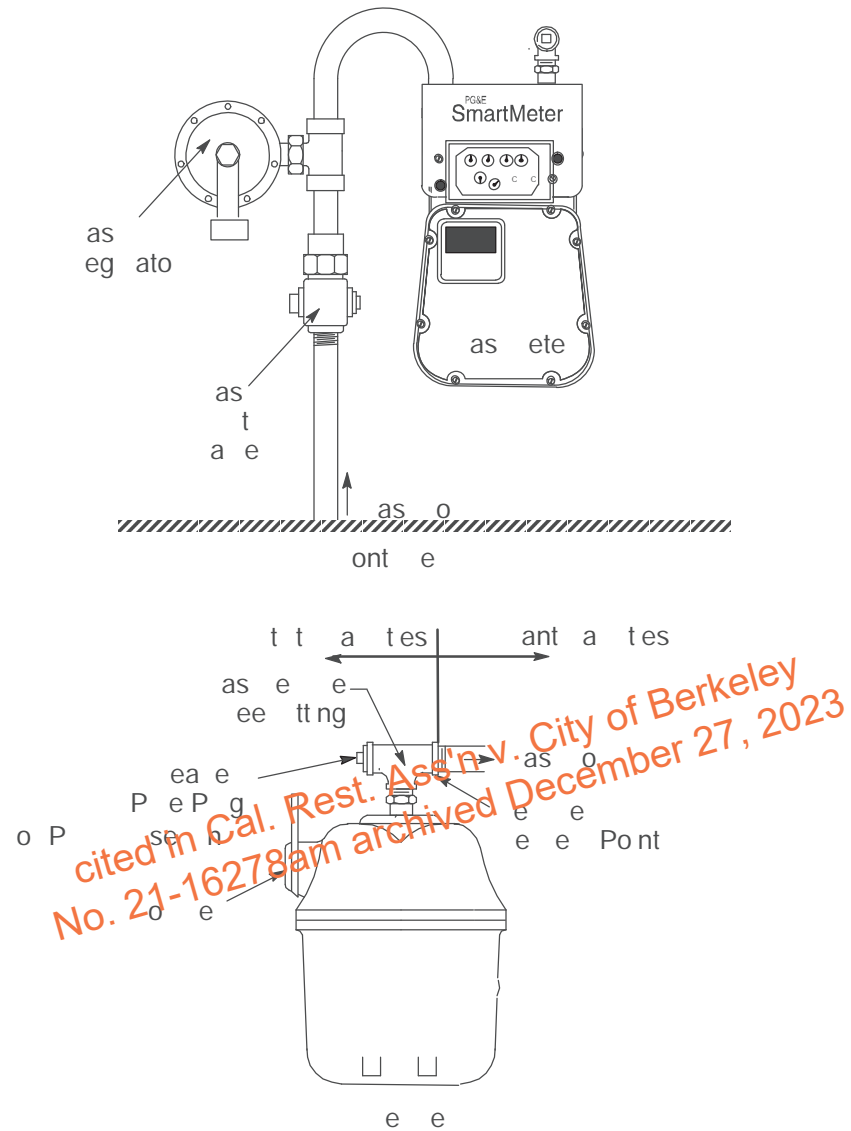


Figure 2-2  
Typical Residential Installations

2 2 Applicant-Owned Riser and Pipe

PG&E recommends that applicants use the gas-riser configuration shown in Figure 2-29, “Recommended, Applicant-Owned Riser and Pipe,” on Page 2- 2, when they install above-ground gas pipe that transitions to underground gas pipe. The preferred riser for most applications is a noncorrodable, prefabricated riser.

Also, PG&E recommends that applicants contact the local authority having jurisdiction before installing ferrous gas pipe and ask for the requirements to protect the underground pipe from corrosion.

Section 2, Gas Service

2. .2. (continued)

- A. Applicants are encouraged to have all buried gas houseline pipe inspected on a regular schedule. Applicants should contact locally licensed plumbing contractors if they need assistance in locating, inspecting, or repairing their buried gas service pipe or other piping equipment.
- B. Applicants must ensure that all required cathodic protection is in place and documented as illustrated in Figure 2-29 below.
- C. Applicants must ensure that their facilities are designed and installed to the requirements of the governmental authorities having jurisdiction. PG&E recommends using the Uniform Plumbing Code, which requires the following protective measures.
  1. Apply a coating and cathodic protection to steel pipelines.
  2. Repair any coating that is damaged during installation.
    - . Install copper tracer wire with nonmetallic gas pipe.
    - . Provide a minimum 18-inch cover for plastic yard pipe used to carry gas.

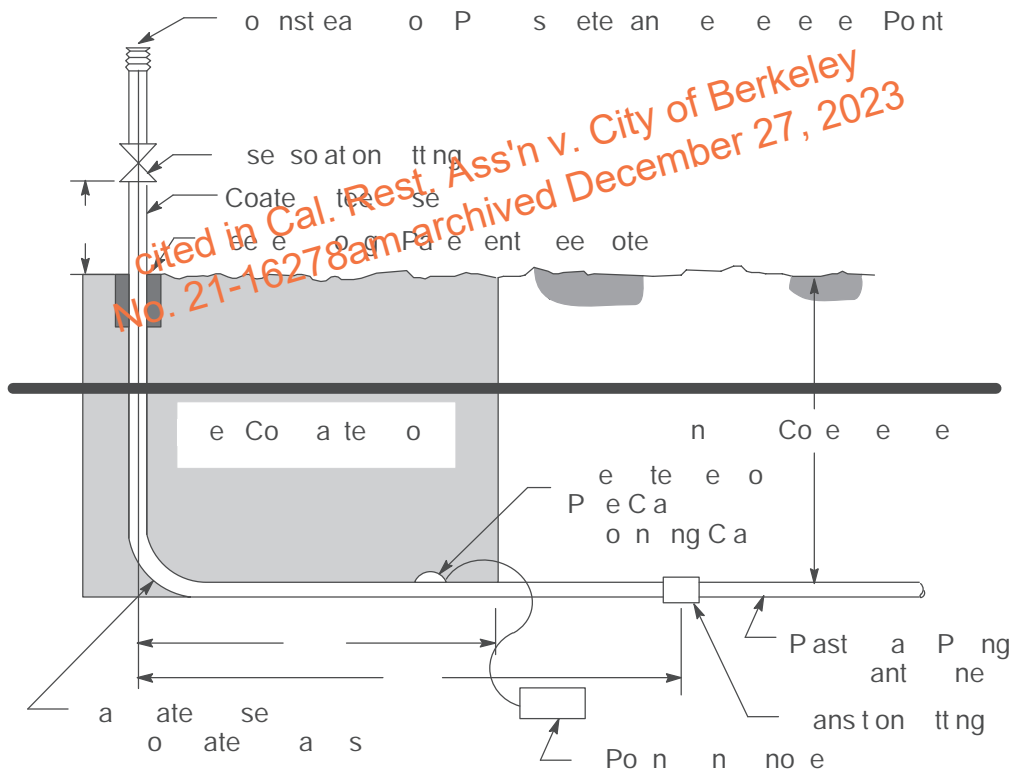


Figure 2-2  
Recommended, applicant-owned houseline riser and pipe

Notes in reference to Figure 2-29.

1. Always maintain a minimum distance of 6 inches between the vertical centerline of the riser and the transition fitting.
2. If the area around the gas riser is going to be paved, install a minimum 18-inch sleeve around the riser.
  - . Comply with city regulations when installing a plastic-to-steel riser (as shown) or a noncorrodable, prefabricated riser on the applicant's houseline.

- 2 Electrically Bonding and Grounding Gas Pipe
- A. Do *not* install electrical devices or equipment, wires, cables, bonding or grounding wires, clamps, or ground rods around the gas meter set as shown in Figure 2-19 on Page 2- and Figure 2-2 on Page 2- 0.
  - B. Do *not* use PG&E's gas service piping, gas risers, or meter facilities for electric bonding or grounding that allows the gas meter, piping, or other gas facilities to become current-carrying conductors.
  - C. Do *not* allow customer houseline to be electrically bonded within meter enclosures, cabinets, or meter rooms.

2 Applicant-Owned Protective Equipment

PG&E's gas metering equipment can be affected adversely when an applicant's equipment causes:

- Pulsations in the gas flow
- Sudden changes in flow rate
- A backflow condition

Applicants must install, at their expense, any equipment necessary to mitigate or eliminate these detrimental effects. PG&E must review and approve these installations before initiating gas service.

Applicants must add any necessary protective equipment when their operations change and those changes could create any of the three adverse conditions described in the bulleted list above.

PG&E may terminate service and refuse to restore that service to any applicant who continues to operate without the proper protective equipment after receiving notification from PG&E.

Applicants are responsible for damages made to PG&E equipment because they did not install the proper protective equipment.

This Page Intentionally Left Blank

*cited in Cal. Rest. Ass'n v. City of Berkeley  
No. 21-16278am archived December 27, 2023*

SECTION  
ELECTRIC SERVICE  
UNDERGROUND

*cited in Cal. Rest. Ass'n v. City of Berkeley  
No. 21-16278am archived December 27, 2023*

SECTION ELECTRIC SERVICE UNDERGROUND



SECTION ELECTRIC SERVICE: NDERGRO ND

*cited in Cal. Rest. Ass'n v. City of Berkeley  
No. 21-16278am archived December 27, 2023*



Know what's below.  
Call before you dig.

## Section Electric Service: nderground

### 1 Scope

This section of the manual provides information to help applicants, as well as their engineers and contractors, select acceptable locations and types of terminations for underground services when connecting to Pacific Gas and Electric Company's (PG&E's/Company's) overhead or underground electric distribution system.

NOTE: For technical information on primary services, refer to [umbered Document 09 6 6, "Primary Electric Service equirements,"](#) and for temporary or permanent service to a post or pedestal, refer to the applicable documents in [Appendix C, "Electric and Gas Engineering Documents."](#)

### 2 General Information

PG&E has the right to access Company facilities located on an applicant's premises at any time, or any purpose connected with furnishing gas and or electric service. Applicants must not access PG&E facilities or enclosures. Only qualified PG&E employees will connect service lateral conductors to (or disconnect them from) PG&E's energized distribution system. This includes installing or removing metering facilities or any other work related to PG&E's facilities or systems.

#### 2.1 Safety Reminder

*City of Berkeley  
Ass'n v. City of Berkeley  
No. 21-16278am archived December 27, 2023  
cited in Cal. Rest.*



**WARNING**

TO AVOID POTENTIAL ACCIDENTS, DO NOT BEGIN TO EXCAVATE BEFORE IDENTIFYING UNDERGROUND FACILITIES



**CAUTION**

Flame resistant (FR) clothing is required while working on, working near, or observing others working on any PG&E facility

State law requires applicants to contact [Underground Service Alert \(USA\)](#) by dialing 811 at least 2 working days before excavation (weekends and holidays excluded). Ensure that you call USA when planning underground work, before digging begins, to allow adequate time for USA to determine the location of underground gas and electric lines or equipment. The potential for an accident exists if applicants fail to request USA to identify underground utility facilities before they begin excavating.



S

## .2.1. (continued)



Dig Safely

First, the applicant must mark the excavation area with white paint. Then,

SA arranges for participating companies to mark the locations of their underground facilities at the jobsite. This is a free service. See the SA color-code identifiers in [Section 1, “General,” Table 1-1, “SA Color Coding.”](#) on Page 1-1, and also on the back of this manual.

Additional information is available at [www.pge.com/digsafely](http://www.pge.com/digsafely) and about

SA services at the SA orth website <http://www.usanorth.org>. SA is a locating service for excavation only. Do not use SA for design purposes.

## 2 2 Establishing nderground Electric Service Responsibilities

Applicants are responsible for constructing, maintaining, and protecting specific portions of underground electric services during construction of their project. The following subsections describe those responsibilities and explain PG&E’s responsibilities during the construction process.

A. Applicants are responsible for obtaining all required permits and easements. This includes local building permits, environmental permits, encroachment permits, public utility easements, and any other permits and land rights that may be required based on the specific location of the trenching/excavation activities.

B. Applicants must ensure that the following construction activities, which may be required to establish underground service, are performed according to PG&E’s standards and specifications, PG&E-approved construction drawings and inspection requirements, and any other permit-specified requirements. This includes construction activities conducted on private property, in the franchise area, or in other rights-of-way areas. Construction activities include:

- Trenching
- Excavation
- Backfill
- Compaction
- nderground conduit (conduit, bends, couplings, end bells, cable protectors)
- Service riser conduit and connector (connects underground conduit to meter panel or termination enclosure)
- Substructures (boxes and pads)
- Paving (cut, patch, and final repair)

C. Applicants must provide satisfactory termination facilities on or within the structures being served. (In this manual, see Sections [6](#), [8](#), [9](#), [10](#), and [11](#), as applicable, based on your project type, amperage, and voltage.) The locations for all transformers and meters, as well as the sizes, types, and quantities of conduit, are subject to PG&E’s specifications and approval.

## .2.2. (continued)

- D. Applicants must not install service conduit, meter, and service equipment in prohibited locations. These include, but are not limited to, outdoor areas less than 00 feet away from biowaste, toxic, corrosive, or similar type of unsafe substances that could be released into the air, are in the ground soil, located in open air wet ponds, or stored in a dry location. See [Section , “Electric Metering: General,” Subsection . .2., “Prohibited Meter and Service Equipment ocations,”](#) on Page - .
- E. Applicants are responsible for owning and maintaining conduit and substructures on private property however, they must convey ownership of any portion in a public (i.e., franchise) area or right-of-way, if applicable, to PG&E.
- F. Applicants are responsible for providing, installing, and maintaining any structures that are required to protect service facilities from damage.
- G. If projects require horizontal Direction Drilling ( DD), applicants or their contractors must contact PG&E before work begins. [PG&E Manual TD- 1 M, ori ontal Directional Drilling Manual](#), as well as [PG&E Procedure TD- 6 2P-01, “Gas and Electric Operations–Cross Bore Prevention and Mitigation,”](#) both outline the construction processes that applicants must follow to be in compliance.

If an applicant does not contact PG&E in advance of construction and does not follow the DD processes identified in the Company documents described above, the applicant will fail the DD installation inspection. It is then the applicant’s responsibility to correct issues noted during the inspection before PG&E accepts ownership of the DD project.

hen applicants are responsible for this trenchless construction, they must take steps to prevent, inspect, identify, report, and address any cross bores that are created during the DD process.

All electric and gas construction work performed either by or for PG&E is subject to these rules, including PG&E gas-for-electric work and other types of applicant-installed work. Find additional information about cross bores at the [Sewer Cleaning](#) website. See <http://www.pge.com/en/safety/gaselectricsafety/sewercleaningsafety/index.page>.

- . PG E is responsible or and re uired to per orm any and all tie-in wor to existing distribution and or energi ed acilities.

.2.2. (continued)

I. PG&E is responsible for furnishing, installing, owning, and maintaining the following service facilities, as applicable.

- Cable/conductors to supply power
- Transformer
- Meter(s) and metering transformers, if required
- Other equipment (e.g., switches)
- User materials (to connect underground service to overhead facilities)

For additional details and options for performing this work, refer to [Electric Rule 15, "Distribution Line Extensions,"](#) and [Electric Rule 16, "Service Extensions,"](#) found online at <https://www.pge.com/tariffs/index.page>.

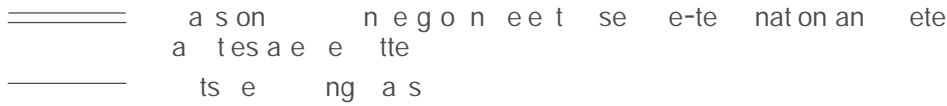
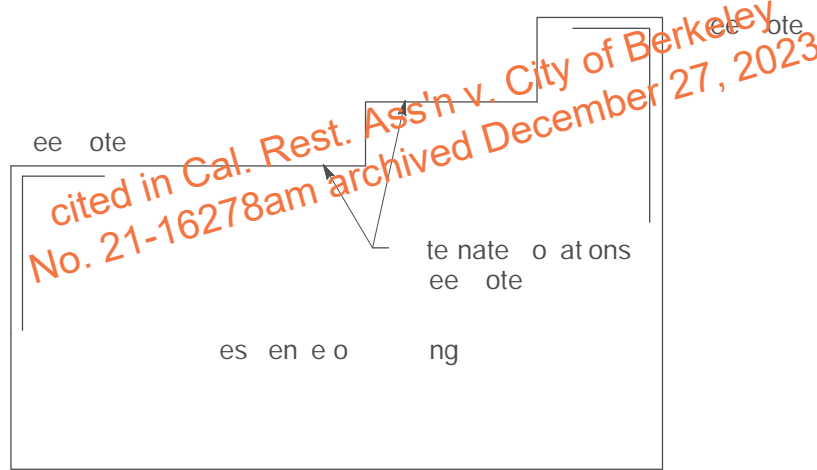
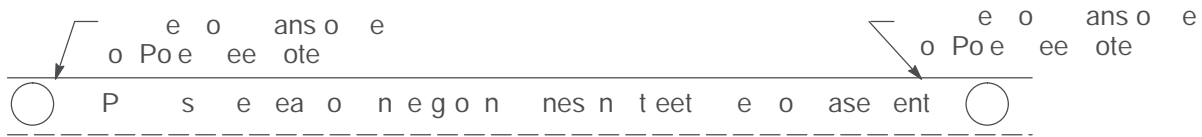


Figure -1  
ocations of nderground Electric Service-Termination and Meter Facilities

otes in reference to Figure -1.

1. If practical, attach the underground electric service-termination facility and the meter to the wall at a preferred location. ocate the facilities as close to PG&E's service facilities as possible to avoid future operation and maintenance restrictions.
2. PG E must approve all service locations before they are constructed.
  - . Applicants must locate the service so that the meter can be read and serviced without entering a fenced or enclosed location, when possible.
  - . Permitted locations for electric service-termination and meter facilities are from Point A.
  - . Permitted locations for electric service-termination and meter facilities are from Point B.

## 2 Installing Ground Rods

Applicants or their contractors are required to install ground rods when PG&E specifically requires them as part of a substructure installation (e.g., when constructing a transformer pad). Find PG&E-approved ground rods and clamps in [umbered Document 01 109, “Corrosion esistant Ground ods and Ground od Clamps.”](#) included in [Appendix C](#).

## 2 Installing E uipment Pads

Applicants or their contractors must construct and install equipment pads, as required, for underground electric equipment. hen constructing a concrete pad for a transformer, use [umbered Document 0 292, “Concrete Pad for Three-Phase, oop-Style Pad-Mounted Transformers.”](#) If installing a box pad for a transformer, use [umbered Document 06 09, “Box-Pad for Pad-Mounted Transformers.”](#) Both engineering documents are listed [Appendix C](#).

For projects that require equipment pads other than for transformers (e.g., PM switches), the project coordinator or PG&E inspector provide these drawings at the pre-construction meeting i the installation is included in the PG&E-approved design.

nderground electric equipment has required working space clearances in front of and all around the equipment. Applicants must ensure the minimum clearances are met. See [umbered Document 0 1127, “Clearances and ocation equirements for Enclosures, Pads and nderground Equipment,”](#) located in [Appendix C](#).

Construct customer-owned, floor-standing switchboard pads (0 600 volts) according to their applications. Figure -2, “Service Conduit ayout Top iew,” on Page -6, and the associated “otes,” provide the placement and arrangement for service conduits inside the utility termination section or pull section.

For primary switchboards, refer to the ground rod and conduit requirements in [Section 11, “Electric Switchboards: 601 olts Through 2 ,000 olts and Primary Services,” Subsection 11. .S.,](#) on Page 11- , and [Figure 11-1, “Primary Switchboard Termination Section Pad Detail,”](#) on Page 11-6.

For additional references to the underground electric documents provided in [Appendix C](#), see Table -2, “Electric nderground Documents,” on Page -2 .

.2. . (continued)

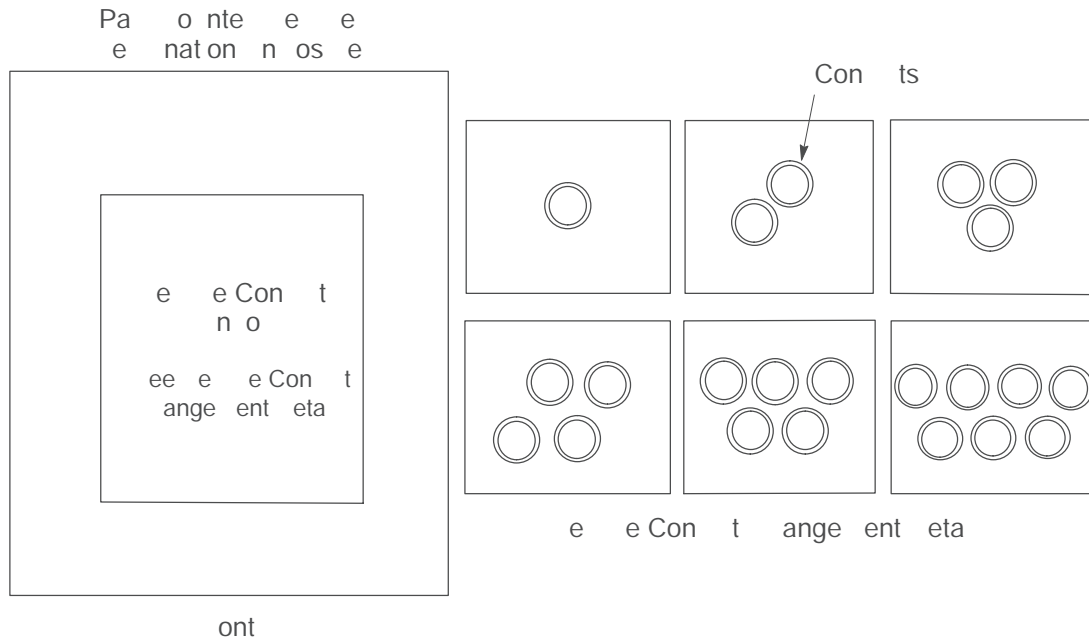


Figure -2  
Service Conduit ayout Top ie

otes in reference to Figure -2.

1. Group the conduits at the service termination (i.e., pull section) enclosure as shown in the “Service Conduit Arrangement Detail.”
2. Center the conduits under the cable termination bus or bus stubs.
  - . Conduits should be separated from each other by approximately 1 inch.
  - . Ensure the top of each conduit is 2 inches above the concrete pad or floor of the switchboard.
  - . Permanently install end bell fittings on all conduits.
6. Temporarily plug or cap all conduits.
  - . Grout conduit windows with nonshrink grout. Do not use asphalt or black top to grout windows.
8. For primary service conduit installations, see [Section 11, Figure 11-1, “Primary Switchboard Termination Section Pad Detail.”](#)

2 Installing Overhead and nderground Service for Two or More Buildings on One lot

If more than two dwellings or buildings are located on the same lot, applicants must consult their local PG&E project coordinators to determine the acceptable service-termination locations and meter locations before wiring the buildings.

NOTE: See [Table FM-1, “Service Planning Office and Inspection Desk Contact Information.”](#) at the front of this manual starting on Page iv, for specific contact numbers listed by area.

## .2. . (continued)

Typically, PG&E only installs one service lateral to a single building on one premise, or to a single enterprise (with either one or multiple buildings) on one premise. However, PG&E may provide more than one service lateral under the following circumstances:

- here it is allowed or required by PG&E's tariff schedules
- For PG&E's convenience
- here it is required by ordinance
- hen it is installed as special facilities

## 2 Inspecting and pproving Overhead and nderground Services

An applicant must contact the local PG&E project coordinator to arrange for a field representative to inspect and approve the applicant-furnished and installed service equipment, as well as any other mandatory components required for an underground service installation.

## 2 7 Easements for PG&amp;E Facilities

ew underground distribution facilities must be designed for installation in a Public ility Easement (P E) outside of public streets and roads. P Es typically only provide the minimum-required land space for the safe and proper installation, operation, and maintenance of the distribution facilities. In some cases, PG&E may require an easement be granted instead of a P E.

Ensure that P Es are at least 10 feet wide for primary, secondary, and service cables. Cables should be installed around the centerline of the P E. If other allowed non-PG&E utilities (e.g., phone, cable) and PG&E facilities (i.e., gas) are installed in the P E, ensure the minimum clearances between facilities are met. Also, ensure clearances to below- and above-grade foreign structures, buildings, and obstructions outside of the P E are met.

Services that cross third-party property also require a 10-foot-wide easement. In some instances, the P E may need to be wider than 10 feet. See Figure - , PG&E Trench and Equipment in P E Example," on Page -8.

In locations along the path of the P E where subsurface enclosures and pad-mounted equipment will be installed, the P E must be wider to encompass the equipment being installed and to meet the minimum required working space clearances that surround the equipment. See [umbered Document 0 1122](#). If the P E does not provide adequate space for equipment and minimum clearances, an easement granted to PG&E will be required.

Contact your local project coordinator for questions on P E requirements, determining the best locations for distribution facilities, and high-density housing projects with short setbacks from the property line.



.2. . (continued)

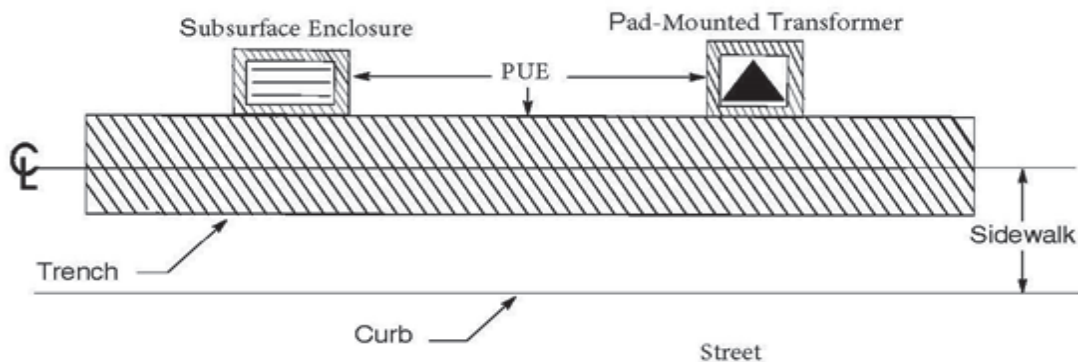


Figure -  
PG&E Trench and Equipment in PUE - Example

## 2 Clearances around PG&E Facilities

Applicants must not construct structures or install equipment, including, but not limited to, buildings, homes, customer generation equipment, agricultural wells, or expansions of existing structures over, under, to the sides, or between PG&E overhead or underground facilities, either in the public right-of-way or on private property, without maintaining the proper clearances. PG&E facilities are typically covered by an easement, right-of-way, or land-right agreement, and require minimum clearances be maintained around the facilities. When in doubt, contact the PG&E and Department and your local project coordinator for help in determining the land rights and clearances required for existing PG&E facilities.

### Underground Service Installation Requirements

#### 1 Installing Services from Underground Distribution Systems

PG&E serves applicants from an underground service if the site or lot is located in an area that is supplied from an existing underground distribution system. PG&E owns, maintains, and installs the underground service lateral conductors. PG&E provides underground-to-underground service along the shortest, most practical, and most available route to the applicant's service-termination facility.

Typically, the termination facility is on or within the building or structure, as shown in Figure - , "Underground-to-Underground Service Connection," on Page -9. PG&E installs the conductors in conduit.

Substructures include conduit, boxes, and transformer pads. Applicants must follow PG&E's guidelines and specifications, including those specified in [Electric Rule 16](#).

PG&E installs the transformer, if required, and connects the service lateral conductors to the applicant's termination facilities.

. .1. (continued)

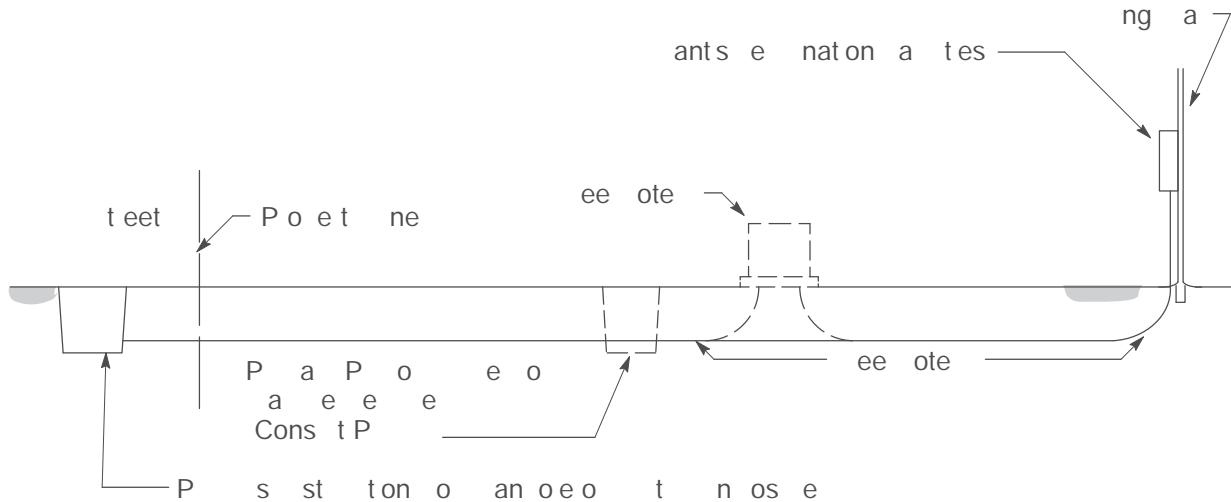


Figure -  
nderground-to- nderground Service Connection

otes in reference to Figure - .

1. When the service delivery voltage is the same as the available, primary distribution voltage (i.e., over 2,000 volts), typically the applicant provides a primary splice box according to PG&E's requirements.
2. PG&E supplies a transformer, if required. (The applicant must provide the trench, backfill, and required conduit, pad, and substructures.)
- . PG&E-owned primary and/or secondary conductors. (The applicant must furnish the substructures.)

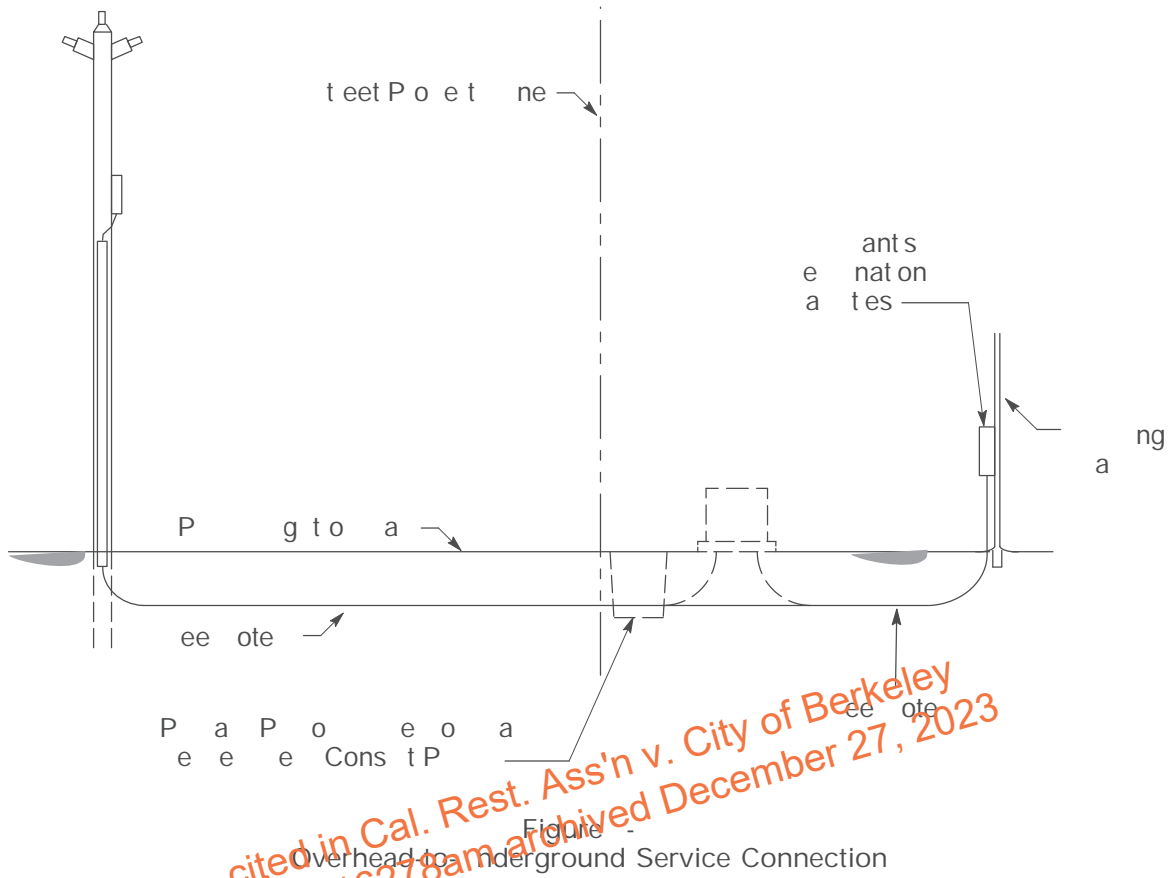
2 Installing Services from Overhead Distribution Systems

PG&E provides service from an underground riser that is installed on an existing pole, as shown in Figure - , "Overhead-to- nderground Service Connection," on Page -10, if any of the following requirements are met.

- A. The applicant is located in an area served from an overhead system and the applicant prefers to have the service installed underground.
- B. The applicant's load requires a transformer that is kilovolt amperes (k A) or larger.
- C. A local city or county ordinance requires underground service.

In these cases, in addition to the requirements described in Subsection . .1., "Installing Services From nderground Distribution Systems," on Page -8, the applicant must pay the material costs of both the pole riser facility and any conduit required in the public right-of-way.

. .2. (continued)



Notes in reference to Figure - .

1. When the service delivery voltage is the same as the available, primary distribution voltage (i.e., over 2,000 volts), typically the applicant provides a primary splice box according to PG&E's requirements.
2. PG&E's pole and secondary riser. (The applicant must pay the installed cost of the pole riser and conduit within the right-of-way.)
- . PG&E-owned service lateral conductors. (The applicant must furnish the conduit, as required.)

## Installing Conduit for nderground Service

NOTE: PG&E will not install its supply cables in conduits that run beneath any building or structure when those conduits do not terminate on or within that building or structure, but are intended to supply another building or structure on the same or another premise.

PG&E requires applicants to install a conduit system for underground service laterals. It is the applicant's responsibility to provide service conduit as described in the following PG&E documents. Refer to the following numbered documents, located in [Appendix C](#).

- [umbered Document 0 819 , “Minimum equirements for the Design and Installation of Conduit and Insulated Cable”](#)
- [umbered Document 062288, “ nderground Conduits”](#)
- [umbered Document 06 92 , “Methods and equirements for Installing esidential nderground Electric Services 0 600 to Customer-Owned Facilities”](#)
- [umbered Document 06 928, “Methods and equirements for Installing on- esidential nderground Electric Services 0 600 olts to Customer-Owned Facilities”](#)

Applicants must ensure that conduit is not installed in a trench at a depth greater than 60 inches. If large utility pipes or drains are obstructing the service path, the trench may be as deep as 10 feet to traverse under the obstructions and then transition back to the proper trench depth.

Conduit runs must have a polyester pull-tape (Code 601 ) to initiate the cable pulling. The pull-tape must be attached securely either to conduit plugs or caps. For spare conduits that will be vacant for 0 days or longer, install detectable pull-tape (Code 6026 9) so the spare conduit can be identified during mark and locate field work.

Applicants must prove that the entire conduit system is free of dirt, rocks, or other obstructions that could prevent, hinder, or harm installing the electric conductors. Applicants must use a PG&E-approved mandrel to prove the conduit system. See Subsection . . , “Mandrels,” on Page -20, for details. A PG&E inspector must approve the equipment and the method, and observe the work being performed to prove the service conduit system's readiness.

Applicants can either choose to perform the underground electric service conduit installation or request PG&E to do the work. Either way, applicants must provide the service riser conduit that extends from the conduit bend out of the ground and into the electric meter panel or service termination enclosure. The service riser conduit must be vertically straight and cannot contain any couplings, offsets, or bends.

. . . (continued)

Applicants must furnish and install either conduit caps or plugs on the ends of all conduits. In addition, at locations where the cable insulation may be damaged (e.g., transformer pads or switchboard pull sections), applicants are required to install cable protection at all of the conduit ends. Applicants should contact their local PG&E project coordinator for specific requirements. Also see [umbered Document 0 819](#) , “[Minimum equirements for the Design and Installation of Conduit and Insulated Cable,](#)” located in [Appendix C](#).

Applicants must be aware that underground conduits, enclosures, and substructures must not be installed in the ground or in buildings foundations before PG&E issues an approved design for the installation. napproved installations are considered “at risk” and the applicant assumes the risk for any work performed without requesting PG&E’s advanced approval. PG&E can charge the applicant if it is necessary to make changes to unapproved work.

PG&E inspectors, at their discretion, can deny or allow at-risk installations. Inspectors also can require pot holing in the foundation and ground or require other inspection methods needed to determine if installation meet requirements.

hen an applicant designs and constructs a PG&E-approved electric room inside of a building, an outside wall must be used as one of the walls of the electric room. The conduits passing through or under the applicant’s building foundation or slab must not extend past the outside wall into the room by more than 20 feet and must terminate inside the electrical room.

refer to [Section](#) , “[Electric Metering: General,](#)” [Subsection](#) . . . . , “[Electric Meter and Service Termination Equipment ooms,](#)” on Page -16, and [Figure -1,](#) “[Allowable ocations for Electric Service and Meter ooms,](#)” on Page -11.

## 1 Galvani ed Rigid Steel Conduit and Couplings

hen new galvanized rigid steel (G S) conduit is used as riser conduit transitioning from the underground service conduit up to the electric meter panel, the following requirements apply.

- The top end of the riser (the end that is inside the meter panel) must be threaded and requires a screw-on lock nut.
- A cable protector is required.
- Do not use set screw couplings or lock nuts on new installations.

The following exceptions apply for existing, rigid-steel conduit risers that will be reused during an electric meter panel change, if applicable.

- If the riser is not threaded, then a conduit lock nut with a set screw is allowed.
- If a coupling with set screws already exists in the riser conduit, then it does not need to be replaced.

. . . (continued)

ew and existing rigid steel conduit does not need to be bonded to the electric panel.

All polyvinyl chloride (PVC) and steel couplings, including plastic-to-steel transition couplings, must be installed below grade and must not be exposed above grade. When a coupling is installed inside of a foundation, the top edge of the coupling may be flush with the top of foundation concrete.

#### Installing PG&E-Only Service Trenches

Applicants must ensure that trenches containing only PG&E electric service facilities or PG&E electric and gas service facilities are covered, as required, when those trenches are located on:

- Private property
- Designated sidewalks
- Parkways
- Driveways

The electric service conduit and gas pipe must be covered on private property or in the franchise as described in the following text. The required minimum clearances must be maintained as listed in Table -1, "Minimum Separation and Clearance Requirements for Service Trenches," on Page -19.

- A. Provide a 2-foot minimum cover for secondary (i.e., 0– 100 volts) electric service conduit and gas pipe.
- B. Provide a 6-inch minimum cover for primary (i.e., over 100 volts) electric service conduit.

The term "cover" refers to the standard distance between the outer surface of an underground facility and the final grade level. The actual trench depth must be greater than the cover depth.

All electric service and secondary conduit must enter PG&E splice boxes or enclosures from the bottom for new construction and not through the boxes' conduit knockouts. If the top of the conduit is not at or below the required minimum conduit depths, the applicant needs to increase the installed depth of the conduit at those locations. See notes in [umbered Document 028028](#), "[Secondary Electric nderground Enclosures](#)," located in [Appendix C](#).

PG&E may require the applicant to provide other means of protecting the service conduit in the following circumstances.

- Increased traffic loading
- Soil erosion
- Open ditches
- Where digging machinery or equipment may be used

This increased protection also may be required in areas where similar situations either are anticipated or exist already.

. . . (continued)

Applicants must ensure that the trench depth is sufficient to meet the minimum depth requirements when taking into consideration the following conditions.

- The required depth of cover (as described previously)
- The size of the conduit that is being installed (e.g., inch, inch)
- The necessary bedding materials
- The size of the electric conduit bends (e.g., 2 -inch or 6-inch bends)

When installing -inch and -inch diameter conduit that requires a 6-inch vertical bend at the pole, transition the trench to a greater depth before reaching the pole to accommodate for the larger radial bend. At the pole, the conduit must extend vertically above grade a minimum of 2 inches to a maximum of 6 inches.

For service trenches (e.g., secondary voltage and -inch conduit) on private property or in the franchise, the required minimum depth of trenches below grade is 0 inches. For primary services, the minimum trench depth is 2 inches for -inch conduit and inches for 6-inch conduit.

Applicants must receive pre-approval from the PG&E inspector when requesting an exception to the minimum-depth requirements. Applicants should contact their local PG&E project coordinator with questions about trench depth.

Applicants should be aware that wet utilities must always be separated from the electric and gas service trench, meters, and risers. Wet utility piping or facilities include, but are not limited to, water, bioswales, storm sewer, sanitary sewer, steam, liquid fuels, oil, diesel, sprinkler, irrigation, spigots, downspouts, drain or leach lines, propane, or lines for other liquids or volatile, heavier-than-air gases. For more information, see [PG&E Standard S](#), "[Joint Trench](#)," [Exhibit B, Joint Trench Configurations Occupancy Guide](#), located in [Appendix B, "Electric and Gas Service Documents."](#)

Also, when applicants plan to install electric service facilities with other services, such as telephone or cable television, they must refer to:

- Subsection . .8., "Installing Joint Utility Service Trenches," on Page -1 .
- Figure -6, "Typical Joint Service Trench," on Page -18.
- Table -1, "Minimum Separation and Clearance Requirements for Service Trenches," on Page -19.

Applicants should contact their local PG&E project coordinator in the development stages of their projects for additional details and requirements about using joint trenches.

### Installing Offsets

In situations where more than two 90° bends are needed, applicants should consult their local PG&E project coordinators to determine whether additional raceway pull-boxes will be required to avoid excessive pulling tension on the service cables.

- A. PG&E does not approve short-radius conduit fittings, commonly known as Bs or service elbows, for use in underground service conduits that are intended to hold PG&E service conductors. Applicants must ensure that offsets are not installed in the following situations.
1. Do not make an offset in the service lateral conduit entering the electric service panel or enclosure.
  2. Avoid making an offset in the conduit system because it may prohibit the use of a mandrel to prove the acceptability of the conduit system.
  3. Avoid making an offset in the service conduit because it will increase the pull tension required to install the service conductors.
- B. In some situations, applicants may be required to perform both of the following numbered actions.
1. Install larger conduits and/or additional splice boxes or pull boxes to accommodate the installation of the conductors.
  2. Transition to cables appropriately sized for the service capacity.
- C. The following scenarios represent situations where B.1. and B.2., on Page 11, could be required.
1. Construction sites where PG&E determines that larger-than-standard cables or conductors are required to maintain voltage and flicker drop.
  2. Construction sites where normal pulling tensions may be exceeded.

NOTE: Applicants must be aware that pin adaptors, cable ringing, or splicing on additional cable will not be used to terminate cables. PG&E does not accept these termination techniques.

### Selecting backfill

Applicants must use backfill (i.e., sand or native soil) to provide a smooth bedding area when installing utility facilities. The backfill must fill all of the voids around the facilities and provide at least 12 inches of cover for the conduit or pipe. PG&E considers soil that contains occasional, rounded rocks that are 1/2 inch in diameter or less to be acceptable backfill.

Crushed rock or sharp-edged materials of any kind, or backfill containing easily breakable dirt clods larger than 6 inches in diameter, are not acceptable.

Additionally, PG&E prohibits applicants to use backfill with rocks greater than inches in any dimension within 6 inches of the top of the pipe or conduit or less than 12 inches below the pavement subgrade.



.6. (continued)

In sections where a shallow trench is needed and allowed, place a cement-slurry cap above the conduit. The cap must be a minimum of inches thick and made from a cement-slurry mix. The mix must consist of a two-sack sand slurry, with red dye mixed in. The cap must rest on rock-free sand and not the conduit. Position the cap at least 6 inches above the conduit. The top of the cap must be a minimum of 8 inches below grade level. The width of the cap must be the same width as the trench.

When backfilling trenches on slopes or grades, bags of concrete and red dye may be required on top of the conduit to prevent the backfill from moving down the slope or running out of the trench.

Soil compaction density must be 90 to 9 and meet PG&E's and any applicable Federal, State, County and local requirements. PG&E-specific soil compaction requirements are as follows:

- A. Trenches that run across or along public roads and streets in the franchise areas must have soil compacted to a minimum of 9 density.
- B. Trenches that run across private roads and streets in non-franchise areas must have soil compacted to a minimum of 90 density.
- C. When PG&E requires a compaction test report for trenches or equipment pads, the testing must be performed by a qualified testing company and the report must include the testing company's information (i.e., name, Address, Contact Information).

All of these requirements are at the discretion of the PG&E inspector. See PG&E's [Joint Trench Configurations Occupancy Guide](#) for additional backfill and trenching requirements. For PG&E-approved import material, see [Engineering Material Specification \(EMS\) 12](#), "Backfill Sand." Both are located in [Appendix B](#).

7 Providing Drainage from the Conduit System

In some conditions, water can enter the wire and conduit system and migrate into the meter panel and/or building. The applicant or applicant's contractor must provide a means to discharge any excess water or water pressure from the conduit system.

The most common method required for discharging water from the conduit is installing a box outside near the base of the riser to the meter panel. Alternate locations may be required by the PG&E inspector or PG&E project coordinator. Any other methods of discharging water will require PG&E's approval before construction begins. For indoor electric meter rooms below grade or at grade level, additional methods of water drainage should be incorporated into the design of the meter room(s) to prevent the accumulation of water.

## Installing Joint Utility Service Trenches

When installing electric services underground, the PG&E gas service pipe and the electric service lateral typically are installed in a common, joint trench. A joint trench also may include telephone and cable television facilities.

Applicants should be aware that wet utilities must always be separated from the electric and gas service trench, meters, and risers. Wet utility facilities are not permitted in a joint trench. Wet utility piping or facilities include, but are not limited to, water, bioswales, storm sewer, sanitary sewer, steam, liquid fuels, oil, diesel, sprinkler, irrigation, spigots, downspouts, drain or leach lines, propane, or lines for other liquids or volatile, heavier-than-air gases.

There are additional requirements for separating a wet utility from a joint trench along with the electric and gas meters and service risers.

Applicants must submit a written request to PG&E when they want to include other facilities in a joint trench. The request must include a justification and be submitted to PG&E for review and approval before excavation or work begins.

PG&E must coordinate joint trench installations with telephone, cable television, or other facilities. This coordination requires lead time, so applicants should submit their requests and justifications as early in the planning process as possible. Applicants must ensure that PG&E has reviewed and approved their trenching plans before digging begins.

Figure -6 on Page -18 illustrates a "Typical Joint Service Trench." Separation and clearance details for the trenches are found in Table -1 on Page -19. Also, see PG&E's [Joint Trench Configurations & Occupancy Guide](#) located in [Appendix B](#) of this manual. This guide contains additional information and joint trench requirements. For PG&E-approved import material, see [Appendix B](#) for [Engineering Material Specification EMS- 123, "Backfill Sand."](#)

When applicants plan to use joint service trenches, they must ensure that the gas and electric meters are installed either adjacent to, or in close proximity to, each other. [Section , "Electric Metering: General"](#) [Section 6, "Electric Metering: Residential"](#) and [Section , "Electric Metering: Nonresidential, Industrial, and Agricultural,"](#) provide information about determining acceptable locations for utility electric meters. [Section 2, "Gas Service," Subsection 2. .2, "Gas Meter-Set Locations,"](#) on Page 2-20, provides information about determining acceptable locations for utility gas meters.

Applicants must discuss the service arrangements and coordinate the meter locations and joint trench requirements with a PG&E project coordinator before installing utility conduits or gas service piping.

Applicants must ensure that when multiple service facilities (i.e., gas, electric, and telecommunications) are installed in close proximity (e.g., in a joint trench), a 12-inch minimum, radial separation is maintained where those facilities transition from below ground to above ground.

. .8. (continued)

PG&E allows an exception to that rule when the separation is between PG&E secondary, electric-service conduit and gas-service piping. In this instance, the minimum separation distance may be reduced to 6 inches. Clearances between other facilities can be reduced only when the facility owners reach a mutual agreement.

When electric underground facilities cross under or over gas facilities, the minimum vertical separation between these facilities is 6 inches. The electric and gas facilities should cross at an angle between 30 degrees to 90 degrees. Crossings less than 30 degrees are considered to be parallel and require the minimum horizontal clearance between the two facilities.

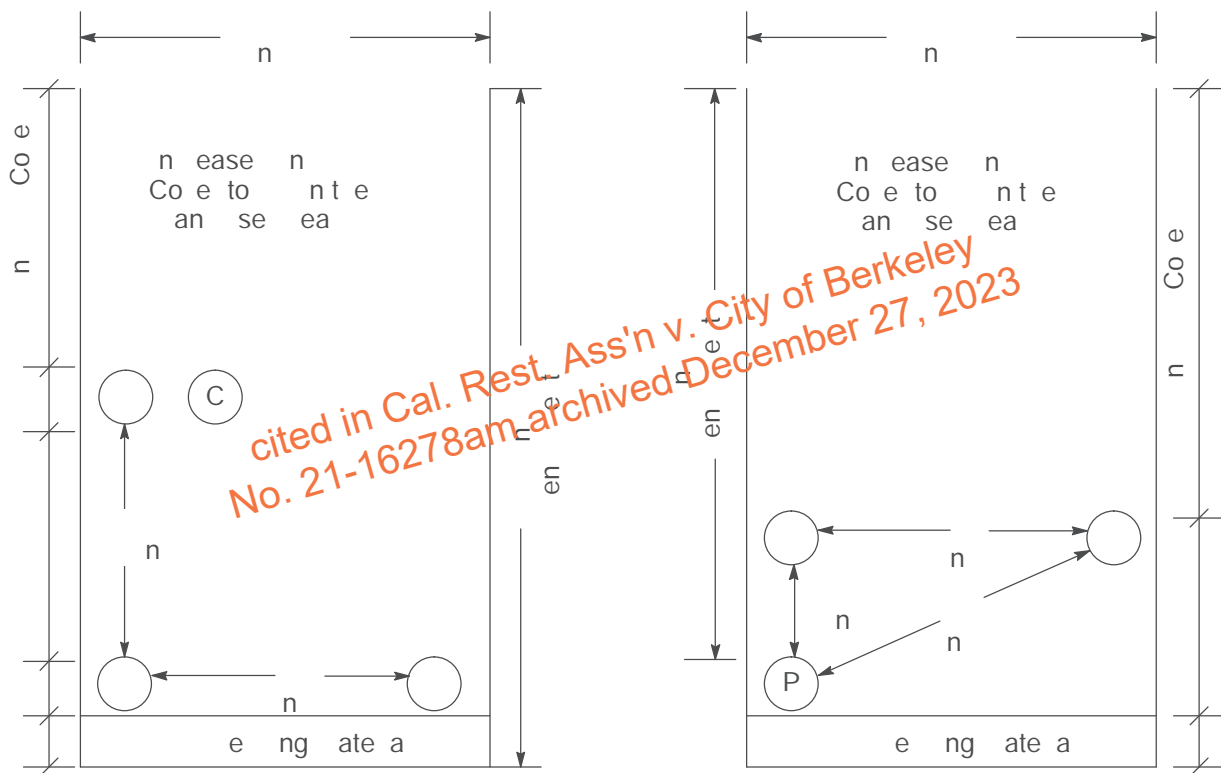


Figure -6  
Typical Joint Service Trench

Figure -7  
PG&E Electric and Gas Service Trench

Notes in reference to Figure -6 and Figure -7.

1. Trench depth will vary depending on conduit size.
  2. Soil compaction must meet PG&E's and any applicable federal, state, county, and local requirements.
- . All separation and clearance dimensions must be met in Table -1 on Page -19.
- . For more information on Figure -6, see PG&E's [Joint Trench Configurations Occupancy Guide](#), located in [Appendix B](#).

. .8. (continued)

Table -1 Minimum Separation and Clearance Re uirements for Trenches<sup>1</sup>

		G	Duct T	D T	C	S	P	S
G	as <sup>2</sup>							
T	ee one t							
T	ee one e t							
C	C							
S	e t e on a							
P	e t P a							
S	t eet g t							
FE	o egn e t o es on P							

se a at on ea an e stan es a e n n es  
o o e no at on a o t t sta e see P etn ate e a at on e e ents o  
[Con t n ont en n en](#) o t s an a  
t eet g t ts not o ned P st en sta e to eet t e e e ents n P s [Joint Trench  
Configurations & Occupancy Guide](#) e a a ants st e e t e e e ents o o ng t a  
se on t t o an  
st e ons ee a t t as e ne n P s [Joint Trench Configurations & Occupancy Guide](#)

Applicants must ensure that adequate amounts of space exist to maintain and operate the facilities. Applicants must ensure that the area immediately behind the gas meter, service facilities, and risers and between those facilities and the premises or structures being served is kept free and clear of all other facilities or equipment such as pipes, wires, cables, or conduits. See [Section 2, Figure 2-19, “Electric and Gas Meter Set Separation Dimensions and Clearances,”](#) on Page 2- .

NOTE: Applicants should consider installing conduit one size larger than the required minimum in case larger cable is required or needed for future upgrades. efer to Subsection 1.1 ., “Determining the Service ating,” on Page 1-1 , for a description of the methods PG&E uses to determine the ampacity (capacity) rating of customer equipment.

Providing a Service-Termination Facility

In addition to the requirements in Table -1, above, applicants must provide and maintain a satisfactory termination facility on or within the building or structure to be served.

PG&E will not install services supplied from different electrical sources in the same termination facility unless the services are separated using suitable barriers. hen two or more services are in one termination facility, the minimum dimensions of each compartment created by the barriers must be the same as if each compartment were a separate termination facility.

NOTE: See new service and current transformer (CT) installation requirements in [Section , Subsection .2. ., “ equirements for Installing Secondary Terminations \(0–600 olts\) in Metering Equipment equiring CTs.”](#) on Page - .

## 10 Bioswales and Large, Wet Locations

A bioswale is a long, channeled depression or trench that receives rainwater runoff and uses vegetation and organic matter to slow water infiltration and filter-out pollutants. A bioswale is considered a wet location and applicants must not install PG&E facilities that go through or close to a bioswale. Bioswale areas should be avoided and PG&E facilities should be designed to go around them. If applicants cannot avoid a bioswale area, they must apply additionally protective methods when designing PG&E facilities. Also see [umbered Document 0 819](#), located in [Appendix C](#).

## 11 Replacing Non-Standard nderground Services

When applicants are relocating or upgrading their electric meter panels and they have existing, non-standard Cable in Conduit (CIC) or Direct Buried (DB) cable, it must be replaced with new PG&E service cable installed in approved service conduit. The new service and conduit run must extend from the new electric panel or termination enclosure location back to the distribution splice box or transformer.

Do not install a splice box along the path of the existing, non-standard DB or CIC cable, between the PG&E secondary distribution system and the panel or termination location, to shorten the length of the new service and conduit. This excludes installing boxes along the new service run near the meter panel to prevent the accumulation of excess water in the service conduit system.

## Electric nderground Documents

Applicants that are performing underground construction should refer to the electric underground numbered documents that are provided at the back of this manual in [Appendix C](#). See PG&E's Internet website at [www.pge.com/greenbook](http://www.pge.com/greenbook) to access the most recent versions of these documents or contact your local PG&E project coordinator. Most of these documents also are available in [PG&E Manual TD-2 02M, Electric Underground Construction Manual, ook 1](#).

## Mandrels

The following section includes both an overview of, and a procedure for using, PG&E-approved, flexible-steel mandrels to prove conduit systems.

## A. Using Mandrels to Prove Conduit Systems

Applicants must ensure that the conduit systems required for PG&E cables and/or conductors are installed in a trench that meets all of PG&E's requirements and specifications for the particular job or project. The conduit systems must meet PG&E's requirements for each specific installations, as well.

NOTE: The term "conduit system" includes conduits, conduit bends, conduit fittings, and all related components (e.g., bell ends and cable protectors) that are needed to install PG&E cables and conductors.

. . (continued)

Applicants must ensure that conduit systems are not covered or hidden from view before the facilities are inspected visually by a PG&E field inspector. The inspector must determine if the conduit system and its installation comply with all of PG&E's specifications (e.g., type, size, schedule, radius of bends) and installation requirements before the customer backfills the trench.

After the conduit system passes PG&E's visual inspection, including visual verification of the conduit system's materials and the radius of the bends, the applicant must backfill the trench and compact the soil. Then, the applicant must provide PG&E with proof that the conduit system is in compliance by successfully inserting and pulling an approved, flexible-steel mandrel through the entire conduit system.

The PG&E inspector remains onsite to ensure that the appropriately sized and approved, flexible-steel mandrel is inserted and pulled through the length of the conduit system without encountering blockages or obstructions.

The applicant must provide the mandrel and follow the procedures for using the mandrel provided in Subsection . .B. on Page -21.

The applicant must provide polyester pull-tape (Code 601 ) to initiate the cable pulling. For spare conduits that will be vacant for 0 days or longer, install detectable pull-tape (Code 6026 9) so the spare conduit can be identified during mark and locate field work.

NOTE: For DD projects, applicants or their contractors must contact PG&E before construction begins. See Subsection .2.2.G. on Page - for information about drilling projects.

#### B. Procedure for Using Mandrels

Applicants must follow the procedural steps below when using a mandrel to prove a conduit system.

Step 1. Select the mandrel that is sized properly for the type of conduit that will be proven. See Figure -8, "Flexible Steel Mandrel," on Page -22, and Table -2, "Mandrel Dimensions, Part numbers, and Order Codes," on Page -2 , for mandrel specifications.

NOTE: For high-density polyethylene ( DPE) continuous conduit only (i.e., -inch, -inch, -inch, and 6-inch DPE), use the next smaller-size mandrel shown in Table -2 on Page -2 .

Step 2. To pull the mandrel through the conduit, securely tie one end of the 2, 00-pound pulling tape to the pulling eye of the mandrel. (The pulling tape was installed in the conduit previously.)

Step 3. Securely tie a second section of 2, 00-pound pulling tape to the pulling eye located on the other end of the mandrel. This section of tape must be long enough to replace the pre-installed pulling tape completely.

. . (continued)

Step . ensures that a run of pulling tape remains in the conduit after the mandrelling process is completed. Also, if the mandrel becomes blocked or stuck in the conduit, the second run of pulling tape allows the mandrel to be pulled back out of conduit and provides a means of measuring the distance to the point of blockage.

Step 4. After both pulling tapes are attached securely to the mandrel, insert the mandrel into one end of the conduit. Slowly start to pull the pulling tape at the opposite end of the conduit. This removes any slack in the pulling tape.

Step 5. Slowly pull the mandrel through the conduit by hand or non-mechanically. The rate of the pull should not exceed 100 feet per minute. Both the person pulling the tape and the PG&E inspector must check the pulling tape for signs of stress (i.e., molten plastic) as the tape comes out of the conduit.

NOTE: The PG&E inspector may not approve a section of the conduit if any portion of the pulling tape shows damage in the form of molten plastic. If the inspector decides to reject the conduit section, he or she will secure the melted section of pulling tape as evidence.

If the mandrel passes through the conduit without encountering any blockage or obstructions, the PG&E inspector approves the conduit section for use.

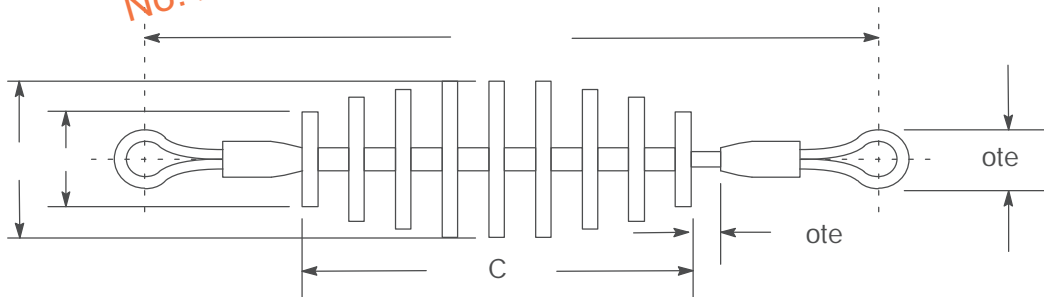


Figure - Flexible Steel Mandrel

otes in reference to Figure -8.

1. The length must be adequate for the mandrel to pass through a 24-inch radius bend (all sizes).
2. The disks must be fabricated from 1/2-inch, flat, steel plate (average weight: 490 pounds per cubic foot) with a 7/16-inch hole for the 3/8-inch cable.
- . The spacers must be fabricated from 1/2-inch iron pipe size (IPS) pipe with a minimum inside diameter of 0.6 inches.
- . Cable size: 3/8-inch, 6 x 19 mild, plow-steel hoisting rope.
- . The outside diameter of the eye must not exceed Dimension A.
6. The size must be stamped permanently into one end of the plates.

. . (continued)

Table -2 Mandrel Dimensions, Part Numbers, and Order Codes<sup>1</sup>

Si e (In Inches)	PG&E Code	Manufacturer Part Numbers	Dimensions (In Inches)				
					C	D <sup>2</sup>	Spacer ength
		-					
		-					
		-					
		-					
		-					

o P ontn os on ton n n n an n P set enets a e s e an e  
 ens ons a e a o ate  
 P sa oe an e an a t e s C esgn an a t ng

Table - usinesses That Sell or Rent Mandrels<sup>1, 2</sup>

Company	Street ddress	City	ip	Phone Number
t t son o atons	Cent a e	e ont		
C	a e e	esho		
C en ng	ng a e e	esho		
C en ng	ange ci	e oe		
Pa t tes Co	stan a	Peasant		
C	te atona	a a ento		
n e en ent e t	a o t e	an Ca os		
C	ea e	anta C a a		
n e en ent e t	esea Pa	o e		
t t son o atons	ast a	a		
t t son o atons	C anne	est a a ento		

an es ste o tea oe an a t e ste n a e onPage C esgn an a t ng  
 sta es o e as a gene a e e en eto o an est at a se o ent P a oe an es to  
 sto es ese o anes a e o ate n tes ot e t ant ose ste nt sta e

*cited in Cal. Rest. Ass'n v. City of Berkeley  
 No. 21-16278am archived December 27, 2023*



This Page Intentionally Left Blank

*cited in Cal. Rest. Ass'n v. City of Berkeley  
No. 21-16278am archived December 27, 2023*

SECTION  
ELECTRIC SERVICE  
ORDER

*cited in Cal. Rest. Ass'n v. City of Berkeley  
No. 21-16278am archived December 27, 2023*

SECTION ELECTRIC SERVICE: ORDER

SECTION ELECTRIC SERVICE ORDER

cited in Cal. Rest. Ass'n v. City of Berkeley  
No. 21-16278am archived December 27, 2023

## Section Electric Service: Overhead

---

### 1 Scope

This section of the manual provides instructions and minimum clearance requirements for attaching permanent, overhead services to residential and nonresidential properties. The term “residential” includes mobile homes installed on foundations in locations other than mobile home parks.

NOTE: Requirements for installing and attaching PG&E overhead services may be different than local city or county ordinances, as well as national or California electric codes. Contact your local PG&E project coordinator if you have questions. See [Table FM-1, “Service Planning Office and Inspection Desk Contact Information.”](#) at the front of this manual starting on Page iv, for specific contact numbers listed by area.

### 2 General

Pacific Gas and Electric Company (PG&E) will not supply new overhead services to applicants when either of the following conditions exist:

- A. When buildings or premises are located in areas designated either by local jurisdictions or by PG&E as underground districts.
- B. When buildings or premises are located in areas zoned for nonresidential or residential use and the installed service equipment and/or load requires PG&E to use a kilovolt ampere (kVA) or larger transformer.

#### 2.1 Safety Reminder



CAUTION

FRAGMENT (FR) CONTACTING IS REQUIRED BEFORE WORKING ON, OR WORKING NEAR, OR OPERATING OTHERS WORKING ON ANY PG&E FACILITY

#### Locating Overhead Services

##### 1 Point of Attachment

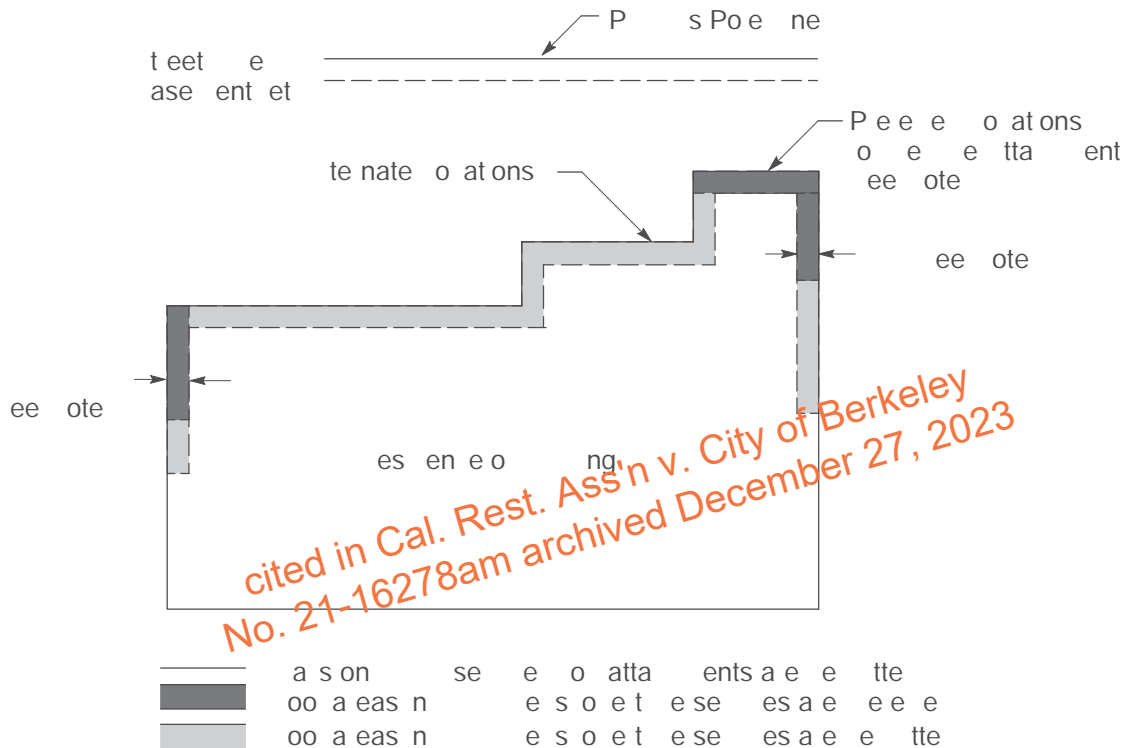
In areas served from overhead lines, PG&E installs an overhead service drop from the Company’s distribution line to a point of attachment on the applicant’s residence, building, or structure. PG&E follows the guidelines listed below to ensure the service is installed safely and efficiently.

- A. The point of attachment must be located so it can be reached with a single span from PG&E’s facilities.
- B. The span should not cross over adjacent property, if possible.
- C. The span must maintain the required, vertical, clearance-to-ground.

. .1. (continued)

The point of attachment may be either on the building wall near the PG&E line or on a periscope fixed to the building’s roof, usually not more than 18 inches in back of that wall. Figure -1 below provides more information about the point of attachment.

Applicants must consult PG&E before installing the building’s wiring. PG&E must approve of the location selected for the utility service attachment.



*cited in Cal. Rest. Ass'n v. City of Berkeley  
No. 21-16278am archived December 27, 2023*

Figure -1

Preferred and Alternate locations for the Overhead Service Drop attachment see notes

notes in reference to Figure -1.

1. Applicants can attach service drops to sidewalls if the service-drop conductors do not exceed feet. Service-drop conductors must not cross over an adjacent property. Finally, applicants must ensure that the required conductor clearances and accesses to the electric meters are maintained.
  2. For more information on meter location requirements, see [Section , “Electric Metering: General”](#) [Section 6, “Electric Metering: Residential”](#) and [Section , “Electric Metering: Nonresidential, Industrial, and Agricultural”](#) (as applicable). For available short-circuit current information and requirements, see [Subsection . .2., “Main Service Disconnect Switch Rated for Amperes Interrupting Capacity \(AIC\).”](#) on Page - 1.
- . The required maximum setback affects nonresidential customers only. The preferred maximum setback is for residential installations, but is not required.

## 2 Two or More Buildings on One Lot

If more than two dwellings or buildings are located on the same lot, applicants must consult PG&E to determine acceptable service attachments and meter locations before wiring the buildings.

Typically, PG&E installs only one service lateral to a single building on one premise, or to one enterprise (with either one building or multiple buildings) on a single premise. However, PG&E may provide more than one service lateral under the following circumstances:

- where it is allowed or required by PG&E's tariff schedules
- For PG&E's convenience
- where it is required by ordinance
- when it is installed as a special facility

## Service Drop Clearances

NOTE: See [Table FM-1](#) starting on Page iv, for specific contact numbers listed by area.

Applicants can request a PG&E project coordinator to specify a location for service drop attachments. When PG&E selects the location, applicants are assured that the service conductors will maintain the required clearances above thoroughfares and structures, as well as the required clearances away from windows, doors, and building exits.

The minimum clearances from the ground, structures, and other objects for overhead service drops are specified in the California Public Utilities Commission's (CPUC's) [General Order \(G.O.\) 95, Rules for Overhead Electric Line Construction](#). Figure -2 through Figure -20 list and illustrate these minimum clearances.

Applicants must ensure that the elevation at the point of attachment is high enough to maintain all of the required vertical clearances. Applicants should allow for normal conductor sag when determining these vertical clearances.

[G.O. 95](#) allows the vertical clearance restrictions for service drops to be reduced in certain instances. PG&E's review and approval is required before any reductions in vertical clearances are allowed. Applicants should contact PG&E as soon as possible in the planning phases of their projects to ensure that any potential problems or exceptions are addressed before construction begins.

Requirements for installing and attaching PG&E overhead services may be different than local electrical codes.

. . (continued)

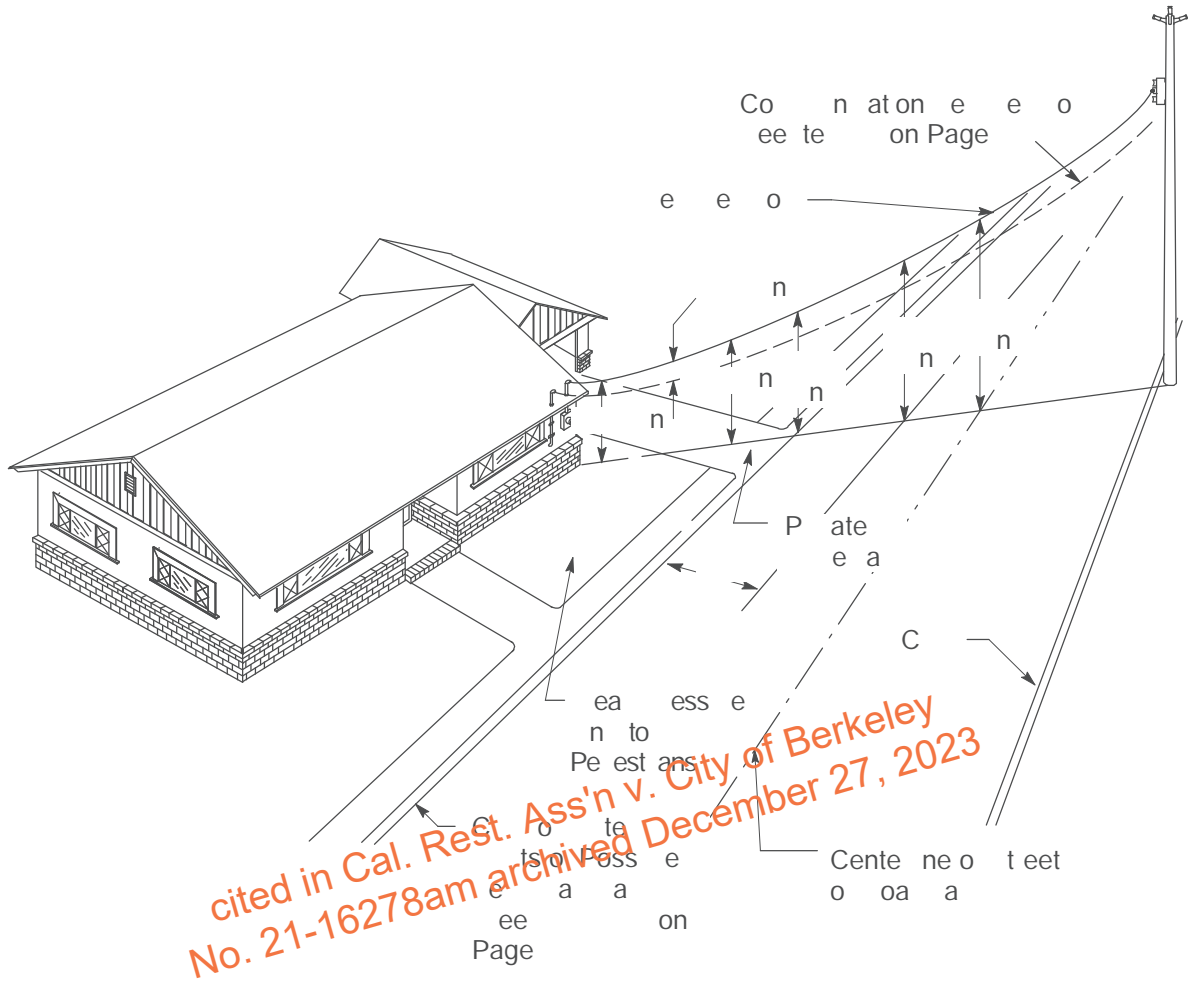


Figure -2  
Ground Clearances for Supply Service Drops, 0 volts Through 7 0 volts, Residential Installations  
(Re uired by the CP C)

1 Vertical Clearance for Residential, Overhead Service

Clearance Above Rails

**Applicants must ensure that the following clearances are maintained when requesting electric service be placed over train or trolley tracks.**

1. Crossing above railroad tracks without overhead trolley wire: 2 feet
2. Crossing above railroad tracks with overhead trolley wire:
  - Above rails where freight cars are transported: 26 feet
  - Above rails where freight cars are not transported: 2 feet

## . .1. (continued)

Clearance above Thoroughfares in Public Areas and in Private Communities of 10 or More Residences

Applicants must ensure that the following clearances are maintained when requesting electric service be placed above thoroughfares in public and private communities with more than 10 residences.

1. Crossing above the center portion between points 12 feet horizontal from curbs: 18 feet
2. Crossing at the curb line (from the level of the street, not the sidewalk): 16 feet
- . Crossing where there are no curbs: applicants must consider the curb line as the outer limit of possible vehicular traffic: 16 feet

## C Clearance Over Residential Property

Applicants must ensure that the following clearances are maintained when requesting electric service be placed over residential property.

1. Crossing over private roads and other areas accessible to agricultural equipment: 16 feet
2. Crossing over agricultural equipment: maintain 16 feet, if possible
  - . Crossing over private driveways or other areas accessible to vehicles: 12 feet
  - . Crossing over areas accessible to pedestrians only: 12 feet

## D Clearance from Communication Service Drops

Applicants must ensure that the following clearances are maintained when requesting electric service be placed over communication service drops.

1. Normal radial clearance: a minimum of 24 inches.
2. Within 10 feet of the point of attachment on a building or structure: the normal radial clearance may be reduced to a minimum of 12 inches.

## E Clearance from Swimming Pools

Avoid installing utility service drops above public and private swimming pools, when practical.

The CPUC, not local agencies or codes, regulates, by its adoption of [G.O. 95](#), the installation and clearances of utility-owned, operated, and maintained supply lines and service drops. [G.O. 95](#) contains specific requirements for installing and maintaining utility supply-line and service-drop clearances above swimming pools. Figure - , “Minimum Clearance for All Drops Above or Adjacent To Swimming Pools,” on Page -6, illustrates the minimum-permitted clearances mandated by [G.O. 95](#) where utility service drops are installed above swimming pools.

NOTE: Table -1, “Minimum Clearances Over Swimming Pools,” on Page -6, also provides clearance information for drops located either above or adjacent to swimming pools.



Section , Electric Service: Overhead

. .1. (continued)

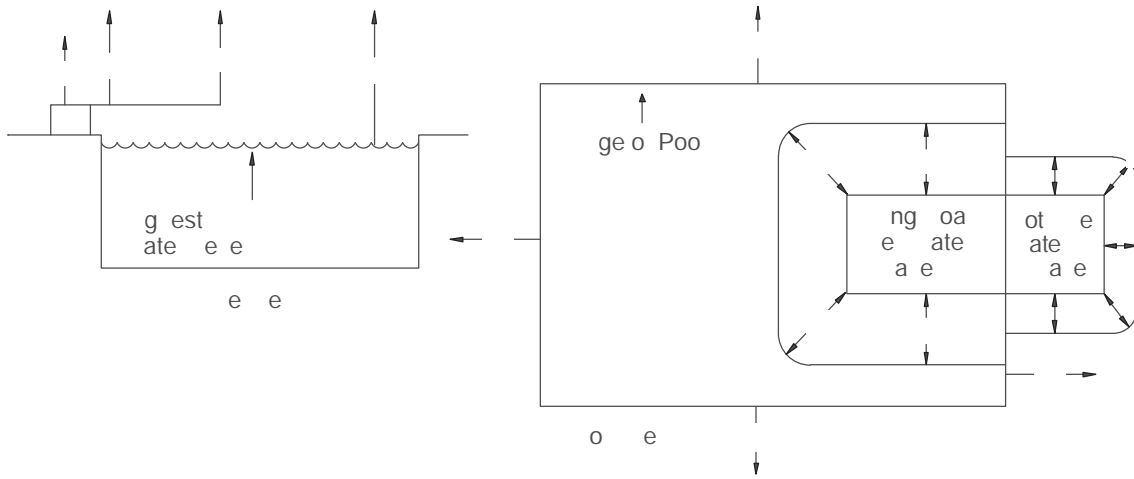


Figure - Minimum Clearance for Utility Drops Above or Adjacent To Swimming Pools

Table -1 Minimum Clearances Over Swimming Pools<sup>1</sup>

Minimum Vertical and Radial Clearances	Vertical	Radial
Unprotected Line Conductors- Vertical Over the highest water level, and Radial from the Top Edge of the Pool walls: 10 feet 10 feet 10 feet	10 feet	10 feet
Service Drops- Vertical Over the highest water level and Radial from the Top Edge of the Pool walls: Pools and non-sentinal Pools sentinal Service Drops (Over Diving boards or Platforms): 10 feet 10 feet	10 feet	10 feet
Guys- Ungrounded Portions: 10 feet 10 feet 10 feet	10 feet	10 feet
Guys- Grounded Portions: 10 feet 10 feet 10 feet	10 feet	10 feet

Clearance from the edge of the pool to the conductors

2 Clearance above buildings

Table -2, "Minimum Allowable Clearance of Service Drops from Buildings-0 volts Through 0 volts," below, lists the required clearances for buildings that are receiving electric service.

Table -2 Minimum Allowable Clearance of Insulated Service Drops from Buildings 0 volts Through 7 0 volts

	Minimum Clearance from Buildings
	Insulated Conductors (See Note 1) 0 volts Through 7 0 volts
Vertical Clearances above:	
Overhead power lines and other overhead lines	See notes and
Overhead power lines and other overhead lines	See notes and
Overhead power lines and other overhead lines	See notes and
Overhead power lines and other overhead lines	See notes and
Horizontal and Radial Clearances:	
Overhead power lines and other overhead lines	See notes and

eat e esstant o ee on ... Const ton e e edts ... Cea an eo e ...

*Rest. Ass'n v. City of Berkeley  
No. 21-16278 am archived December 27, 2023*

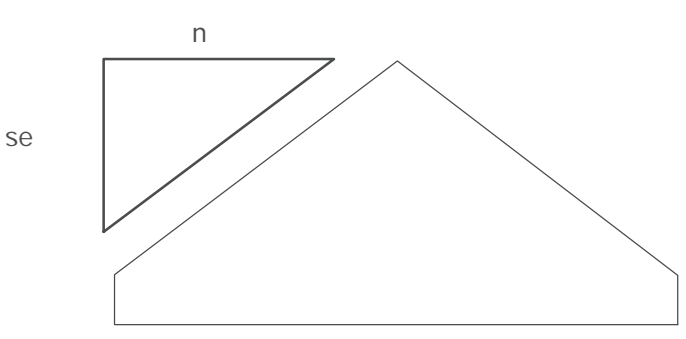


Figure - Nonmetallic Roof

Clearance at the Residential Point of Attachment

PG&E recommends that applicants do not locate electric supply and communication services in the same vertical plane. Figure -11, one of the “Clearance at the Residential Point of Attachment” illustrations on Page -9, shows the recommended arrangement for the communication service drop.

- A. Typically, applicants the service drop is attached below the level of the service weatherhead however, it may be attached above the service weatherhead, as shown in Figure - and Figure -9, both located on Page -9, if the two following situations exist.
1. It is impractical to attach the service drop below the level of the service weatherhead.
  2. The service-drop conductor’s attachment point is located 2 inches or less from the service weatherhead.
- B. Applicants must ensure that the line length of the open wiring (i.e., drip loop) between the point of service attachment and service weatherhead does not exceed feet.
- C. Applicants must ensure that the clearance requirements for the PG&E overhead service are met. These clearances may be greater than local electrical codes.
- D. PG&E will not attach services to periscope structures made of plastic. Figure - through Figure -11, all representing “Clearance at the Residential Point of Attachment,” provide examples of clearances for overhead service-drop installations and terminations. These seven figures are located on Page -9.

NOTE: For overhead, temporary services, see umbered Document 02 0, “quirements for Customer-Owned Poles.” in Appendix C, “Electric and Gas Engineering Documents.”

NOTE: Refer to umbered Document 09 6 6, “Primary Electric Service Equipment.” in Appendix C, for technical information on primary services.

. . . (continued)

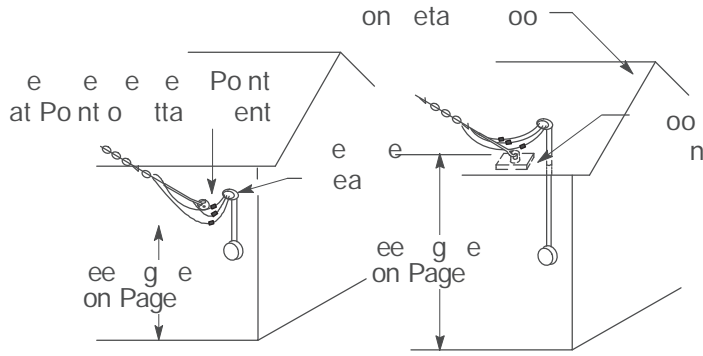


Figure -

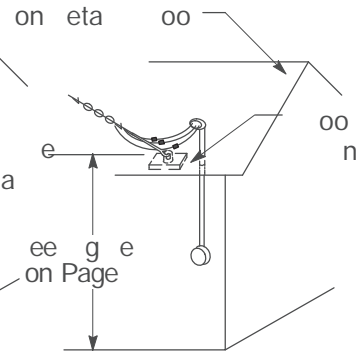


Figure -

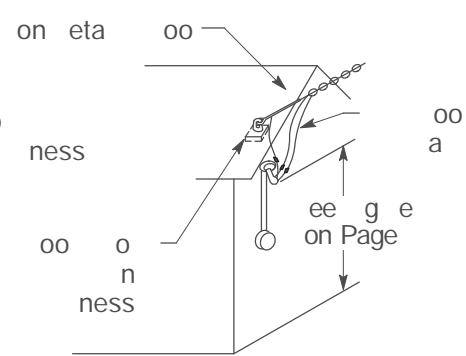
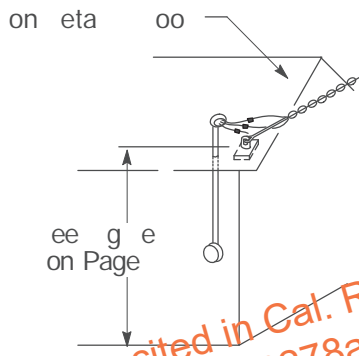


Figure -7



Figure

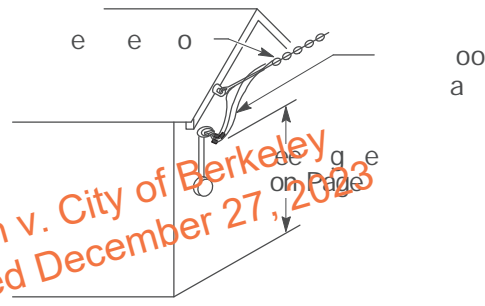


Figure -

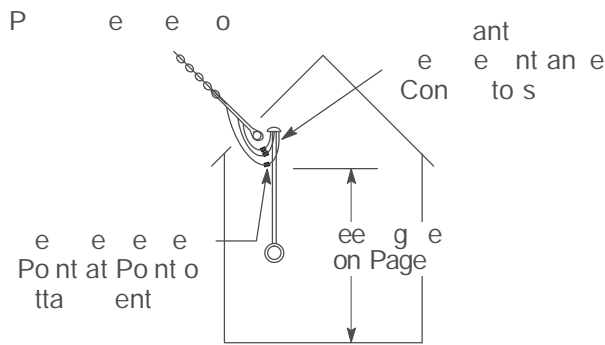


Figure -10

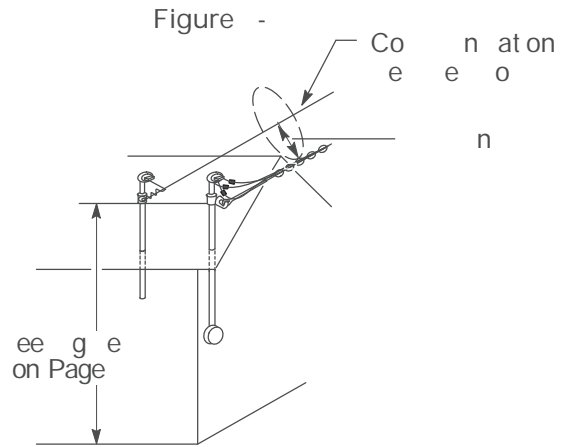


Figure -11

Clearance at the Residential Point of Attachment

ertical Clearance on Nonresidential Property

Table - , “ ertical Clearance from the Ground on onresidential Property,” located below, provides the minimum vertical distance (in feet) from the ground on nonresidential property.

Applicants must ensure that periscope attachment structures are constructed with one of the following, approved materials.

- 1-1/ -inch minimum, galvanized rigid steel (G S) or intermediate metal conduit (IMC) rigid steel
- 2-inch minimum rigid aluminum conduit measured in iron pipe size (IPS) dimensions

PG&E will not attach a span to plastic periscope structures.

Periscope extensions projecting above the roof may require bracing against the pull of the service-drop conductors, as shown in Figure - 9, “ nbraced Periscope Structure ( esidential and onresidential),” on Page -2 .

Typically, the service drop is attached below the level of the service weatherhead however, it may be attached above the service weatherhead if both of the following situations exist.

- It is impractical to attach the service drop below the level of the service weatherhead.
- The attachment point on the service-drop conductors is located less than 2 inches from the service weatherhead.

Ensure the length of the open-wire drip loop does not exceed feet.

PG&E connects the Company’s service conductor and an applicant’s service-entrance conductor below the service weatherhead.

Table - ertical Clearance from the Ground on Nonresidential Property<sup>1</sup>

Description	Minimum ertical Distance (In Feet)
erate eas nes an ote eas eg a e san a ng ots a ess eto e es	
e a eas a ess eto e est ans on	
e ngs an ges o o e st t es att e o natta et at o not o na s ot on to san on eo e an a	

Cea an e e e ents a e e entt an o a e e t a o es

A. Clearance from Communication Service Drops

Applicants must ensure that the following clearances are maintained when requesting electric service to be placed over communication service drops.

1. ormal radial clearance: a minimum of 2 inches.
2. ithin 1 feet of the point of attachment on a building or structure: the normal radial clearances may be reduced to a minimum of 12 inches.

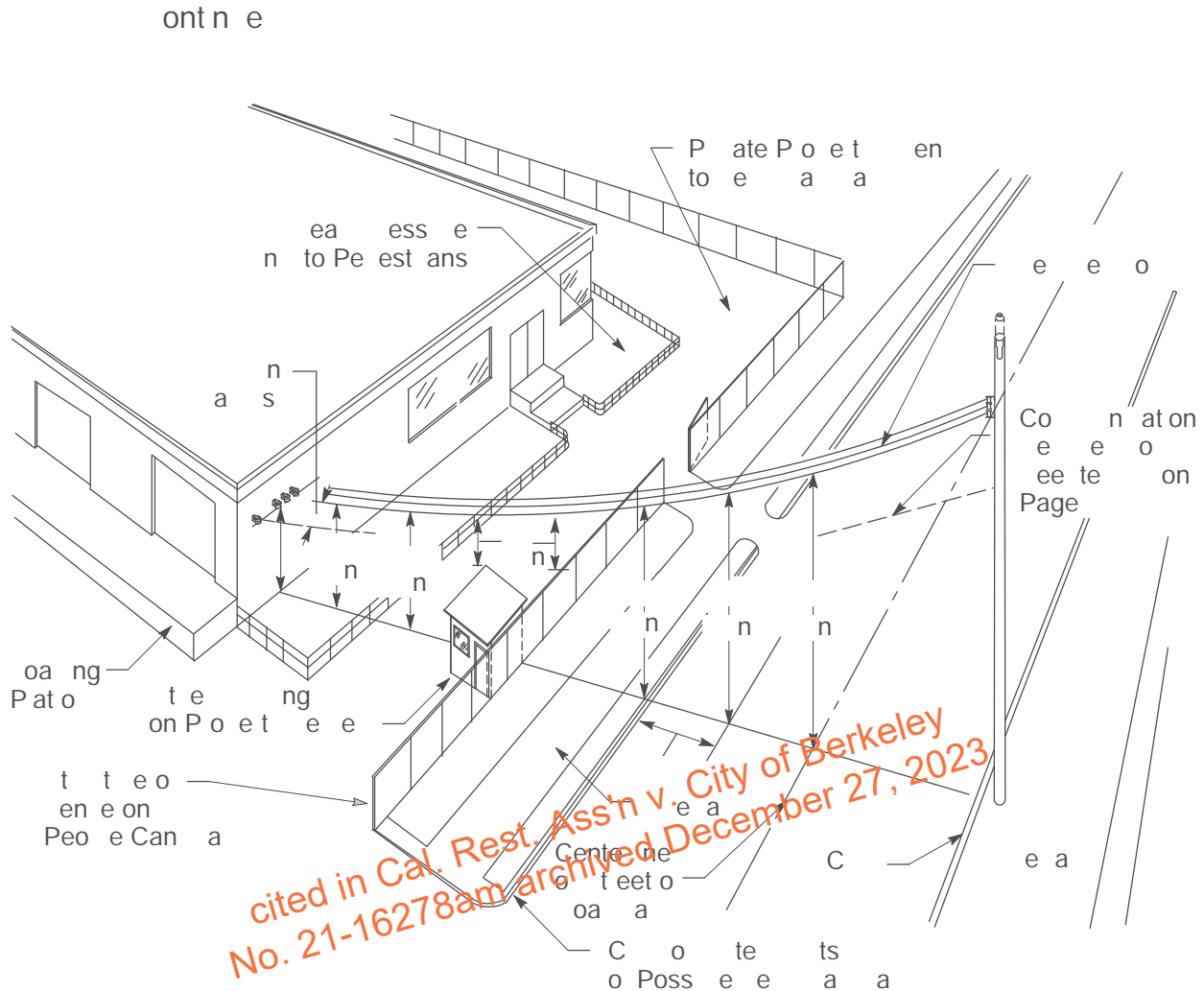


Figure -12  
Ground Clearances for Supply Service Drops, 0 volts Through 70 volts, Industrial and Nonresidential Installations (Required by the CP C)

Figure -1 through Figure -20, all representing “Clearances for Nonresidential Buildings Using Insulated Conductors” and all located on Page -1 , show overhead service drops and vertical-clearances, as measured from the ground, for nonresidential and industrial installations and large residential buildings.

Clearances for a Nonresidential Building Service Drop Using Cable or Equally Insulated, Open-Wire Service Conductors

Applicants can use the clearances shown in Figure -1 through Figure -20 only when they use Type -SD service-drop cable, or equally insulated cable, open-wire service conductors. Applicants must not use weatherproof-rated conductors.

Figure -12, “Ground Clearances for Supply Service Drops, 0 volts Through 70 volts, Industrial and Nonresidential Installations (Required by the CP C),” located above, provides the required clearances from a service drop to the ground.

. . . (continued)

Figure -21, "Clearance Around indows," and Figure -22, "Clearance Around Doors," both located on Page -1 , provide applicants with the required clearances from fire escapes, exits, windows, doors, and other locations where people could be present.

Applicants must use a 1-1/ -inch minimum G S or IMC rigid steel, or 2-inch minimum rigid aluminum conduit (IPS dimensions) for all periscope attachment structures. See Figure -1 , Figure -1 , Figure -1 , Figure -19, and Figure -20, all representing "Clearances for onresidential Buildings sing Insulated Conductors," on Page -1 , for examples.

The clearances shown in Figure -1 through Figure -20 only apply to insulated services, up to a 0-volt maximum, over nonmetallic roofs or decorative appendages. Applicants also should refer to the service-entrance, conductor-clearance requirements found in the State uilding Standards Electrical Code.

The special 2 -inch minimum clearance, illustrated in Figure -20, is applicable only to service-drop cable.

Either brace the periscope attachment structures as shown, or ensure that the structures are supported using similar, acceptable methods. For more information on bracing periscope attachment structures, see Figure - and Figure - , both representing "Service to onresidential Premises," and both on Page -18. Also, see Figure 8, "Braced Periscope Attachment Structure," on Page -20, and Table - , "Maximum Mast eight Above the oof Without Bracing," on Page -2 .

*No. 21-16278am archived December 27, 2023*  
*cited in Cal. Abst. Ass'n v. City of Berkeley*

. . . (continued)

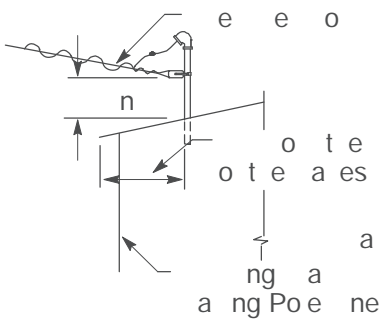


Figure -1

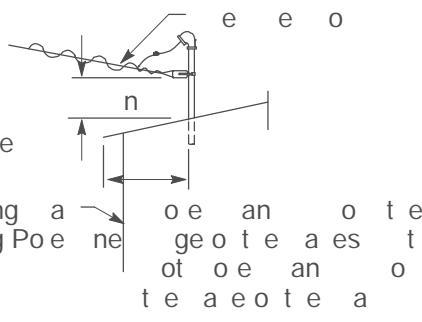


Figure -1

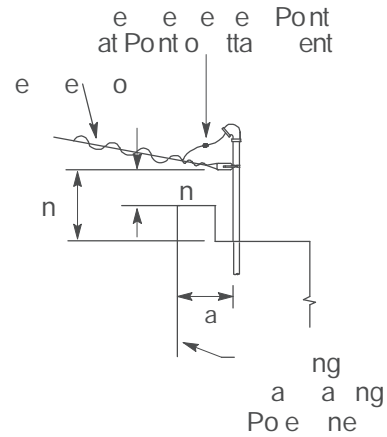


Figure -1

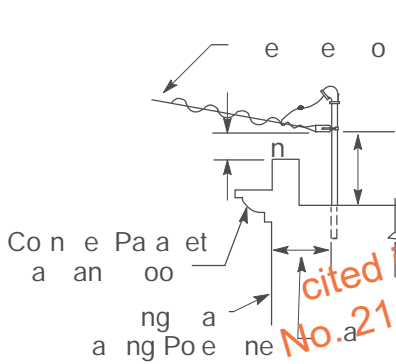


Figure -1

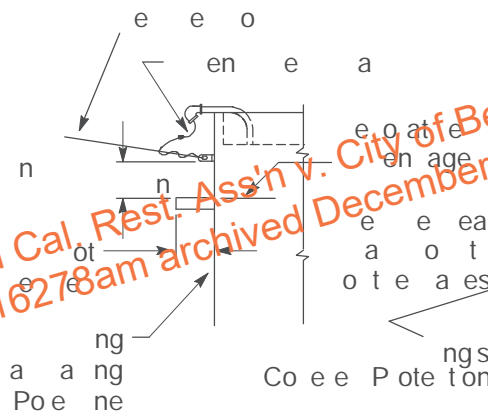


Figure -17

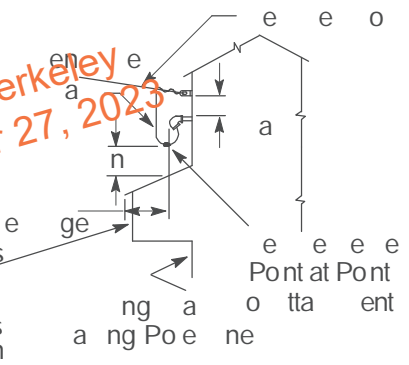


Figure -1

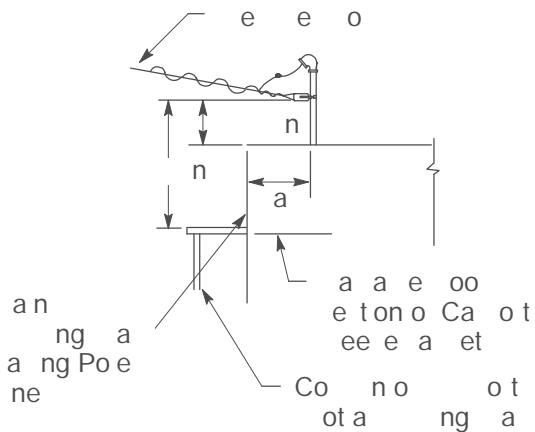


Figure -1

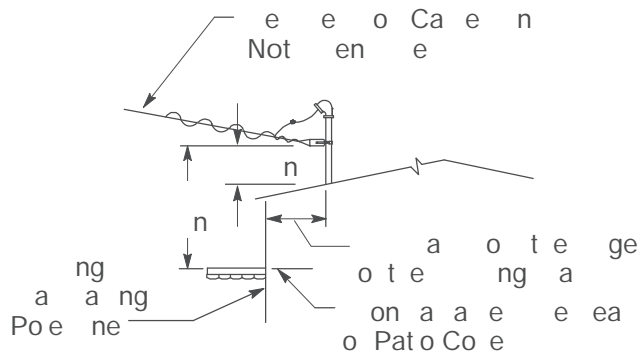


Figure -20

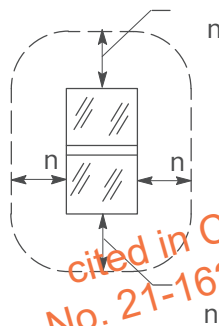
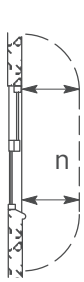
Clearances for Nonresidential Buildings Using Insulated Conductors (0 volts - 70 volts)



Clearances round Doors and indo s

Service drops are not required to clear buildings by any specified horizontal distance however, applicants must ensure that the service weatherhead, the service drop, and the open wires between the service weatherhead and the service drop maintain the following clearances from fire escapes, balconies, stairways, exits, doors, windows, and other locations where people could be present.

- A. Wires that are either at or below the level of the top of exits, doors, windows, and other openings must have a radial clearance from the boundaries of such openings of not less than feet, as shown in Figure -21 below.
- B. Wires less than 8 feet above, or feet below, the surface levels of fire escapes, balconies, porches, stairways, and walkways must have a minimum horizontal clearance of at least feet from such surfaces, as shown in Figure -22 below.



cited in Cal. Rest. Ass'n v. City of Berkeley  
 No. 21-16278am archived December 27, 2023

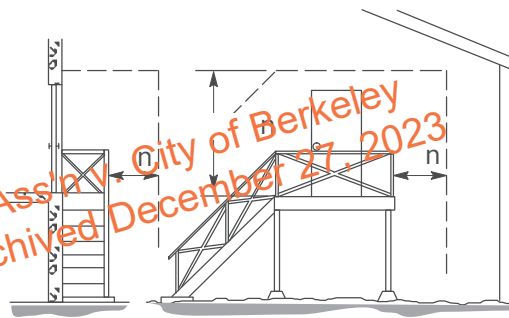


Figure -21  
Clearance round indo s

Figure -22  
Clearance round Doors

7 Clearance et een Service Drop ires

The minimum-allowable radial clearance between service drop sites (i.e., 0 volts through 0 volts) in the span from the pole to the building, and a point of attachment to the building, is inches. Applicants must ensure that wire supports at the building are spaced 8 inches apart, where practical.

Clearance from Applicant-Owned Service Poles

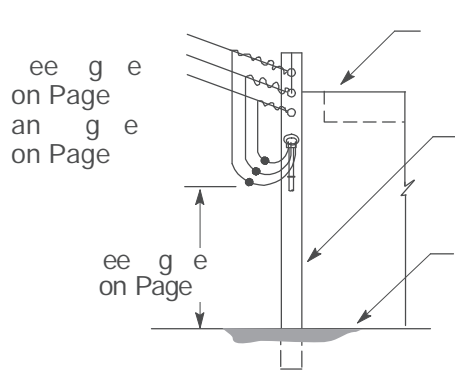


Figure -2  
Service Attachment Structure or Service Pole Secured to a Building

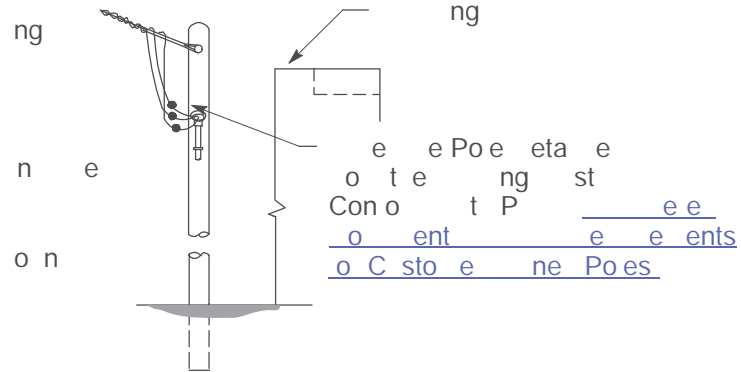


Figure -2  
Service Pole Detached from a Building

Service Attachments

Applicants must ensure that utility service drops (i.e., 0 volts through 000 volts) are not attached directly to metal roofs.

1. Attaching 0- volt through 000-volt Residential, Overhead Service Drops

Applicants must ensure that the service drop's point of attachment to the building is high enough to provide the minimum legal clearances shown in Figure -2 on Page -2 .

Subsection .6., "Attachment Structures (Periscopes)," on Page -21, provides information on installing and using periscopes as attachment structures.

Whenever practical, attach the service drops below the level of the service weatherhead, as shown in Figure -29, "Cable (Single Spool)," and Figure -30, "Open Wire or Cable (Cable Shown)," both of which are on Page -16, and Figure -39, "Inbraced Periscope Structure ( Residential and Nonresidential)," on Page -2 .

In all installations, PG&E connects to the applicant's service-entrance conductor below the level of the service weatherhead. Drip loops are included at the entrance of each conductor to the service weatherhead. These drip loops prevent moisture from penetrating the installations.

The standard service attachments shown in Figure -2 through Figure -30, all representing "0-volt Through 000-volt Service at Residential Premises," on Page -16, are designed according to the CP C's State Building Standards Electrical Regulations to California electrical code and to PG&E requirements. Local authorities may have additional requirements.

Section , Electric Service: Overhead

. .1. (continued)

NOTE: PG&E will attach a service knob to a stud (e.g., 2 inch x inch) or rafter, if possible. PG&E will not mount the service knob directly to the roof or attach it to corner trim or roof trim without a 2-inch x -inch stud or larger. Figure - 6, "Building Attachment Service knob," Detail A, on Page -20, provides the requirements for attaching service knobs.

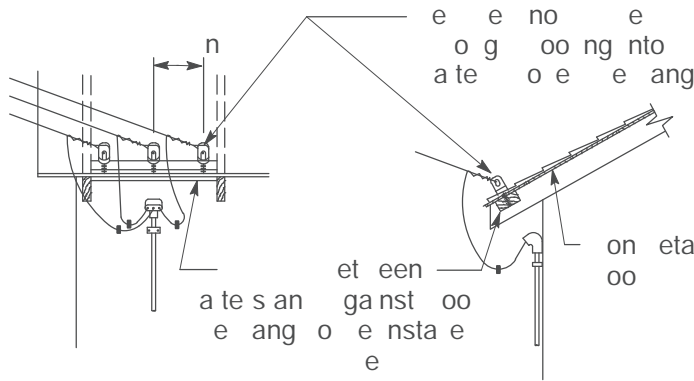


Figure -2  
Open wire

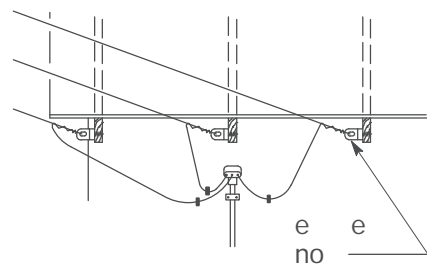


Figure -2  
Open wire or Cable  
(Open wire Show n)

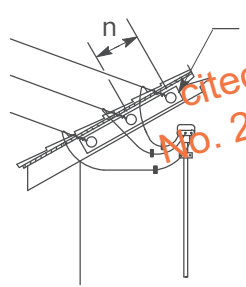


Figure -27  
Open wire or Cable (Open wire Show n)

Cited in Cal. Rest. Ass'n v. City of Berkeley  
No. 21-16278am archived December 27, 2023

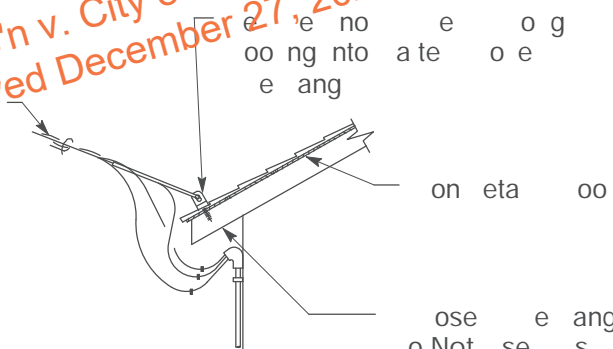


Figure -2  
Cable (Single Triple)

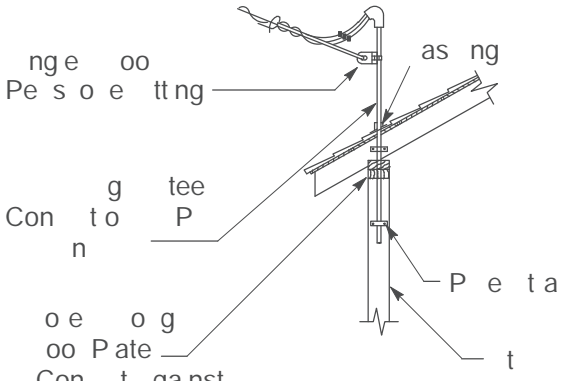


Figure -2  
Cable (Single Spool)

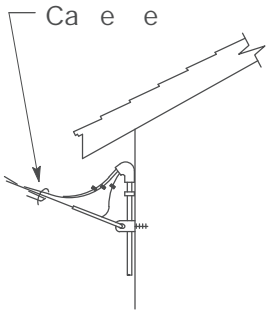


Figure -0  
Open wire or Cable  
(Cable Show n)

0- olt Through 00- olt Service at Residential Premises

2 Attaching to - voltage, Nonresidential, Overhead Service Drops

When applicants plan to install service-entrance wiring larger than that shown in Figure - 1 through Figure - , all representing “Service to Nonresidential Premises” and on Page -18, they must consult PG&E before they begin construction to obtain instructions on attaching the wiring properly.

Figure - 1, “Service Drop Cable, 1/0 and Smaller, Triplex or Quadruplex,” shows applicants how to attach the wiring using service knobs in either concrete or masonry walls. Service knobs must be screwed into wood-frame walls.

Figure - 2, “New All, 1/0 kcmil to 9 . kcmil Aluminum,” shows applicants how to attach the wires using insulated clevises on concrete walls. For wood-frame walls or masonry walls (e.g., brick, hollow tile, cinder block), applicants must bolt the attachments through the wall. Where service is attached to masonry walls, applicants must install bracing or attachment structures.

When it is practical to do so, applicants must attach service drops below the level of the service weatherhead.

PG&E furnishes the bolts and insulators needed to secure the service drop to the building or attachment structures. Applicants can attach the service drop to the walls or to periscope structures either horizontally or vertically.

The wire sizes shown in Figure - 1 through Figure - refer to service drops, not to service-entrance wires.

Open wiring, or drip loop, installed between the service drop attachment and the service weatherhead, must not exceed feet.

Applicants must install periscope structures as illustrated in Figure - 9 on Page -2 . See Subsection .6. on Page -21 for additional information on installing periscopes and using periscopes as attachment structures.

Section , Electric Service: Overhead

. .2. (continued)

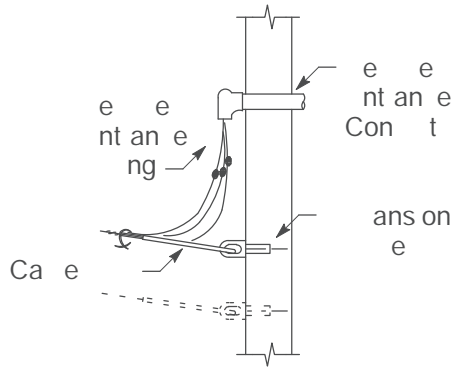


Figure - 1  
Service Drop Cable, #10 and Smaller,  
Triple or Quadruple

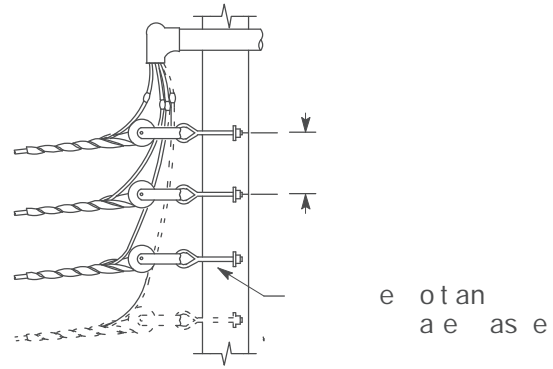


Figure - 2  
Ne all, #10 kcmil<sup>1</sup> to #7 kcmil aluminum

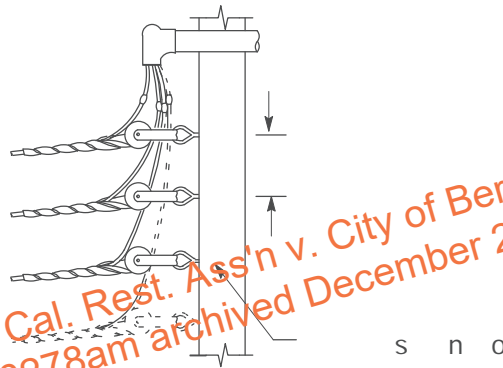


Figure -  
Ne or E isting all, #10 kcmil<sup>1</sup> to #7 kcmil aluminum

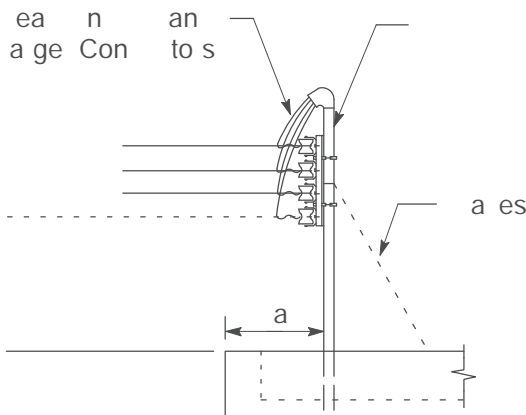


Figure -  
Open Wire Service, #10 to #7 kcmil<sup>1</sup> aluminum

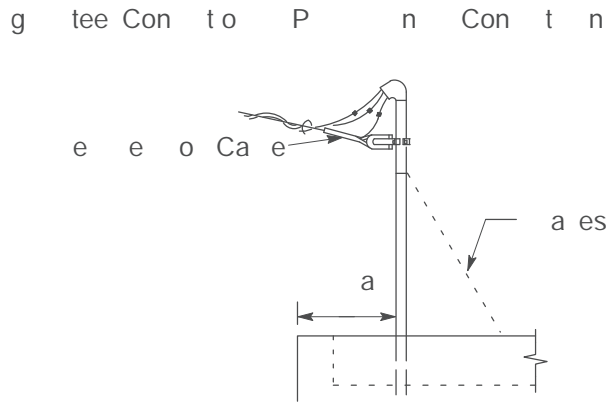


Figure -  
Service Drop Cable

Service to Nonresidential Premises

ote in reference to Figure - 2, Figure - , and Figure - .

1. kcmil: a thousand circular mils

Special Service Attachment Requirements: Areas Subject to Heavy Snow Loading

The following special requirements apply to service drops installed in snow-loading areas. PG&E has designed these requirements to minimize storm damage.

- A. Applicants must ensure that the span length of triplex or quadruplex service drop cable used in snow-loading areas is 12 feet or less.
- B. Applicants should locate the service weatherhead as high as practical to keep the weatherhead clear of deep snow.
- C. Applicants should try to attach service drops to house gables, where practical. This type of attachment protects the service and meter equipment from being impacted by snow and ice as it slides off the roof.
- D. PG&E will attach a service knob to a stud, if possible. PG&E will not mount the service knob directly to the roof or attach it to corner trim or roof trim. Figure - 6, "Building Attachment – Service Knob," Detail A, on Page -20, provides the requirements for attaching service knobs.
- E. Applicants should install a self-supported, periscope attachment structure according to the requirements specified in Subsection .6. on Page -21 and Table - , "Maximum Distance (Inches from the Service Attachment to the Top Periscope Support)," on Page -20.

Typically, periscope attachment structures that are installed as specified in Subsection .6 and Table - , "Maximum Mast Height Above the Roof Without Bracing," on Page -2 , provide a sufficiently rigid service-drop support to withstand the expected snow loading. In areas above ,000 feet, use the construction methods shown in Figure - 6, where practical.

Section , Electric Service: Overhead

. . . (continued)

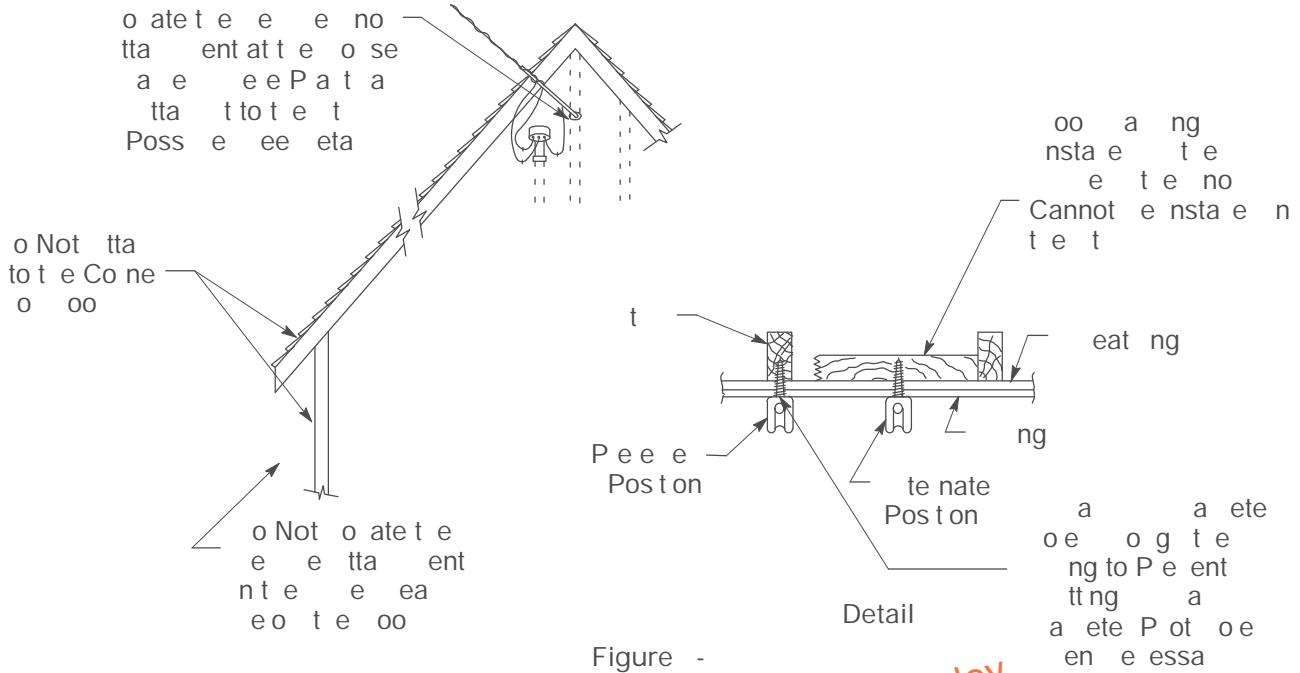


Figure - Building Attachment Service Knob

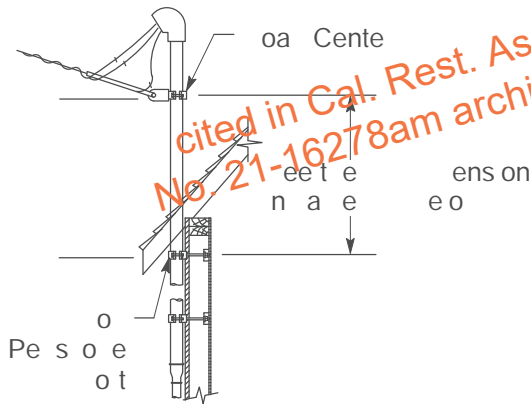


Figure - 7 Self-Supported Periscope Attachment Structure

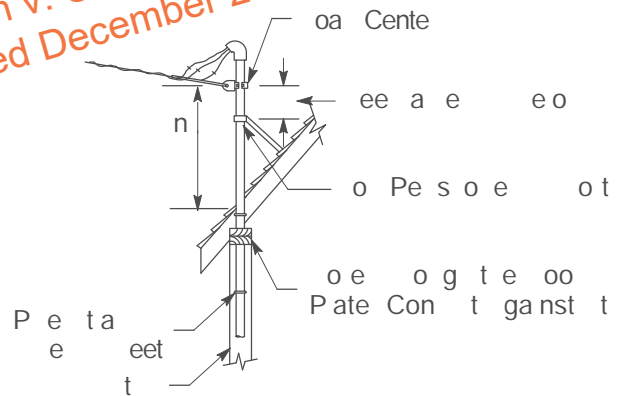


Figure - Raced Periscope Attachment Structure

Table - Minimum Distance (Inches from the Service Attachment to the Top Periscope Support)

Type of Service Periscope	IPS Side of Service Periscope (In Inches)				
	1-1/2	1-1/2	2	2-1/2	
Conical					
Non-Conical	Not Permitted				

gagane g steel  
 Centre e ate eta on t  
 a et e s o e a s s o n n g e to antanas ent ea an e o e t e oo

### Attachment Structures (Periscopes)

An attachment structure is a support that connects the service drop to the structure while maintaining the clearances required for the service drop. Applicants must ensure that the service drop maintains the required clearance at its point of attachment to the periscope, mast, or other attachment structure. These clearances are mandated by the CPUC's [G.O. 95](#).

PG&E will connect service drops to attachment structures in either one of two ways.

- A. Connect by using either spools or insulators that are installed on a building.
- B. Connect by using a single mast constructed of one of the following galvanized rigid pipe or conduit materials.
  - Steel
  - Intermediate metal
  - Aluminum

Applicants using Method A must only install a single (one) mast and weatherhead from the electric service termination and metering equipment to the service drop location. Applicants using Method B must only install a single (one) mast, periscope, and weatherhead from the electric service termination and metering equipment to the service drop location. Installing more than one attachment structure is prohibited.

To provide structural support for periscopes, applicants should use a heavy-duty, 2-hole pipe strap every 4 feet, secured by 1/8-inch x 3/4-inch lag screws (minimum size). Structural support is required at the location shown in Figure 9, "Unbraced Periscope Structure (Residential and Nonresidential)," on Page 2.

When applicants must install attachment structures to maintain the required clearances, they must contact PG&E for approval before constructing the structures. PG&E must ensure that attachment structures meet all of the applicable legal requirements.

Applicants must install and maintain these attachment structures at their expense.

The attachment structures must be strong enough to support the service drop wires and service attachments. Applicants may use a single (one) service-entrance conduit as the attachment structure. In this case, the periscope must be a minimum 1-1/2-inch GFS conduit or IMC, or 2-inch IPS rigid aluminum conduit.

Applicants may not use plastic conduit as an attachment structure.

Subsection 16.10.1, "Special Service Attachment Requirements: Areas Subject to Heavy Snow Loading," on Page 19, provides applicants with additional requirements when using attachment structures in snow-loading areas.

When applicants use attachment structures, either on exterior walls or on roof structures, they must ensure the attachment structures provide the required clearances. Additionally, applicants must ensure that buildings are constructed or reinforced to support the weight of the attachment structure and fitting. Buildings must be able to withstand the pull of the service wires. Applicants must furnish all of the materials required to install the attachment structures except the racks, bolts, and insulators needed to secure the service wires. PG&E supplies those parts.



## .6. (continued)

Attachment structures typically must be installed directly above the service termination and metering equipment, vertically upward to the weatherhead location. The service entrance mast (conduit) should not be installed in either a diagonal or horizontal position unless approved by PG&E. For existing installations where the meter panel is being replaced and relocated away from the gas facilities, or to achieve the minimum-required working space, the mast may be installed horizontally to be able to run back to the existing weatherhead location if it is not changing. Refer to [Section 2, "Gas Service," Figure 2-19, "Electric and Gas Meter Set Separation Dimensions and Clearances,"](#) on Page 2- , for gas clearance requirements. Any horizontal run of mast (conduit) should not exceed 10 feet and must not be installed on top of the roof. If a new attachment structure is installed, it should be directly above the new service termination and metering equipment.

Applicants may not attach communications conductors, such as those used for telephone or cable television service, to the electric supply's power-service mast or attachment structure. Applicants can attach only electric-utility, power-supply, service-drop conductors to the electric-supply, power-service masts or attachment structures.

If a new meter panel is planned to be installed next to an existing meter panel and connected to the same overhead service, applicants may not install additional masts and weatherhead and are required to install a sealable gutter in conjunction with a single mast.

## 1 Periscope Clearances and Bracing Requirements

Applicants must ensure that periscopes and raceway-type service masts extend a maximum of 8 inches and at least 12 inches above any roof or eave they may penetrate. Applicants may be required to raise periscopes and raceway-type service masts when using them as attachment structures and/or to obtain the appropriate clearances for service drop conductors. For more information, see Figure -1 through Figure -16, all on Page -1 . Also, see Figure - , "Open Wire Service, to 9 . kcmil Aluminum," and Figure - , "Service Drop Cable," on Page -18. Finally, see Figure - 6 through Figure - 8 on Page -20.

Applicants may have to brace periscopes that project above the roof lines, as shown in Figure - 9 and Table - . An acceptable method of bracing is illustrated in Figure - and Figure - . Table - lists the maximum periscope heights that applicants can install without bracing for different types of conduit.

The periscope (i.e., mast) height without bracing is limited to 0 inches above the roof in either of the following two locations.

- here the service drop is installed through trees
- here trees or tree branches may strike or cause unplanned loading on the service drop.

Applicants must ensure that unbraced periscopes projecting above roofs or eaves are continuous without couplings from the point where the utility service drop is attached to the periscope to 0 inches below the roof or eave.

.6.1. (continued)

When the periscope structure requires support above the roof, applicants must ensure that it is braced, not guyed, as shown in Figure - 8. The brace must be located as described in Table - . When applicants need to brace periscope structures, the bracing must consist of two galvanized steel members installed at an approximate 90° spread. Braces must consist of a minimum 1/2-inch galvanized steel pipe or 1-1/8-inch x 1-1/8-inch x 1/8-inch galvanized steel angles.

Table - Minimum Mast Height Above the Roof Bracing<sup>1</sup>

(IPS) Conduit Size		Minimum Mast Height Above Roof Bracing
GRS <sup>2</sup> or IMC	Aluminum	
All Measurements in Inches		

Section on Page of the Code  
 galvanized steel  
 Code of the City of Berkeley  
 Person(s) to be contacted  
 or install on the roof and set in place  
 See also

cited in Cal. Rest. Ass'n v. City of Berkeley  
 No. 21-16278am archived December 27, 2023

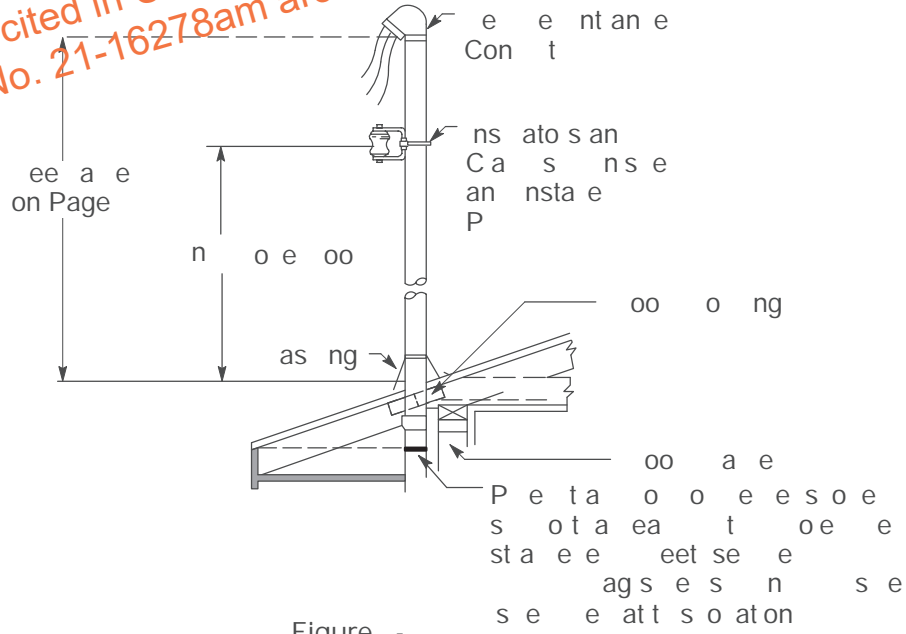


Figure - Unbraced Periscope Structure (Residential and Nonresidential)

## 7 Service weatherheads

Typically, applicants should not locate the service weatherhead on exterior walls that are less than 2 feet from a common property line. The service weatherhead should be higher than the point of service attachment.

Applicable California state laws require applicants to locate the service weatherhead so that they maintain the minimum clearances specified in Subsection . . ., “Service Drop Clearances,” on Page - , through Subsection . . ., “Service Attachments,” on Page -1 . These minimum clearances also apply to the service drop and the open sites between the service weatherhead and the service drop’s point of attachment.

In some instances, applicants may need to install the service weatherhead and related open wires at an elevation greater than the minimum required clearances. Adding the extra height ensures that the installed service drops maintain the required clearances above the ground and any affected structures. Also, the required clearances may be greater than local electrical codes.

A service weatherhead must be located above the service-drop conductor’s point of attachment however, the service-drop attachment may be located above the service weatherhead if both of the following conditions are met.

- A. If it is impractical to attach the service drop below the level of the service weatherhead.
- B. If the attachment point on the service-drop conductor is located less than 2 inches from the service weatherhead.

Ensure that the length of the open-wire drip loop does not exceed feet.

### Service-Entrance Conductors

Applicants must furnish, install, and maintain the service-entrance wiring and service equipment beyond the point where it attaches to PG&E’s overhead service drop.

PG&E will only connect to one set (run) of service-entrance conductors exiting the mast and weatherhead. Therefore, applicants must only install one set of conductors in the service conduit. One set or run is a maximum of three conductors for single-phase and four conductors for three-phase services.

The type and size of service-entrance wires must conform to applicable legal requirements and must be approved service-entrance cable. If applicants use an approved service-entrance cable, they must ensure that the service-entrance wires are enclosed either in a single (one) continuous metallic tubing or in rigid conduit of a type and size to conform to applicable requirements, but preferably 1-1/ inches or more.

**NOTE:** On periscope-type installations, use a minimum 1-1/ -inch G S or IMC, or 2-inch IPS, rigid aluminum conduit. It is prohibited to install more than one conduit (mast), periscope, and weatherhead for service-entrance conductors.

.8. (continued)

If applicants use SE-type service-entrance cables between the service weatherhead and meters, they must ensure that the SE-type cables are not concealed. Also, applicants must ensure that service entrances are rain tight by using approved fittings.

In residential and small nonresidential installations, applicants may install short-radius conduit fittings (i.e., Bs, service elbows) in the overhead, service-entrance conduit system.

Because this conduit system penetrates the outer building wall, applicants must install the short-radius conduit fittings with covers that prevent water from penetrating the fittings. The covers also must be sealable by PG&E personnel.

NOTE: Short-radius conduit fittings should not contain splices or taps.

The drip loop is the length of exposed wire between the service weatherhead and the service drop. Applicants must not use more than feet of exposed, open wiring to form the drip loop.

To create drip loops, an applicant should install a minimum 18 inches of service-entrance wiring that extends out from the service weatherhead. In cases where the service-entrance open conductors pass over a roof or firewall with a minimum clearance of 12 inches, applicants must provide enough wire for PG&E to connect to the service drop and to obtain the required 12-inch minimum clearance above the building.

PG&E connects the Company's service conductors and the applicants' service-entrance conductors below the weatherhead.

PG&E furnishes and installs connectors for joining the service-entrance conductors to the service drop. Drip loops must not extend around the corner of a building however, the service weatherhead may be located on the same face of the building as the service-drop attachment. The service-entrance conduit or cable may be extended around the corner of the building to the meter and service switch.

Do not install conductors other than service-entrance conductors in the conduit leading to the meter.

applicant-Owned, Installed, or Furnished Wood Poles

PG&E project coordinators will explain the requirements to ensure that applicants are familiar with the inspection process and requirements for installing and using the wood poles.

For poles that have a final height greater than 20 feet above ground level, the Federal Aviation Administration (FAA) may require the applicant to file a notice a minimum of days before installing the pole. The FAA may issue a determination of hazard to air navigation and recommend actions to mitigate or eliminate the hazard. Please contact your PG&E project coordinator for additional information.

## .9. (continued)

After discussing or meeting with project coordinators and finalizing their installation plans, applicants must notify their local PG&E project coordinators before setting wood poles. It is critical that applicants who own, install, or furnish approved wood poles to which PG&E can attach equipment or facilities, or to which PG&E can furnish or supply permanent electric service, meet the requirements of [umbered Document 02 0](#), found in [Appendix C](#). After the applicant installs the pole(s) in the ground, PG&E field inspectors will approve the installation of poles that meet Company requirements.

PG&E field inspectors verify the following, specific requirements for applicant-furnished poles before approving their installation.

- A. The poles must be supplied and treated by a PG&E-approved supplier.
- B. The applicant must obtain and provide PG&E with a copy of a “Certificate of Treatment” from the pole supplier. That certificate must indicate that the pole was treated according to the requirements of both the American Wood Preserver’s Association and the American National Standards Institute (ANSI).
- C. Applicants must ensure that new poles are branded or tagged. This identification must be either 10 feet from the pole butt for poles less than 10 feet long or 1 foot from the pole butt for poles more than 10 feet long. The brand must include the following four identifiers:
  - The manufacturer’s name
  - The month and year the pole was treated
  - The wood species
  - The preservative used to treat the pole
- D. Poles greater than 10 feet long that will support PG&E primary facilities must be through-bored at the ground line.
- E. PG&E must inspect and approve used poles before they are reused (i.e., PG&E facilities are reinstalled on the poles). PG&E-owned poles that have been removed from service and will no longer be used by PG&E cannot be reused as customer-owned poles.

The PG&E field inspector must verify that the poles meet the dimensional and test requirements for reused poles. These requirements are described in [PG&E Procedure TD-2 2 P-01, “Inspecting, enforcing, and using Wood Poles.”](#)

If installing overhead temporary services, refer to [umbered Document 02 0](#), found in [Appendix C](#).

## 10 Required Vegetation Clearances

The state of California requires electric utilities to keep electric lines (i.e., high-voltage lines) cleared of vegetation. All newly constructed distribution lines and existing lines must meet these requirements.

NOTE: PG&E may determine that the distribution line should be installed underground, or that trees should be removed, if the planned line extension does not meet or exceed the clearance requirements between existing trees and overhead electric lines. See new options for commercial agricultural orchards in Subsection .10. . on Page - 1.

## 10.1 General Requirements

When establishing new overhead services, and/or when building or remodeling structures near high-voltage lines, poles, or towers, applicants must research planting regulations and follow the rules established here.

NOTE: Applicants must consider safety and access for repairs when planting near an overhead electric service.

- A. Where required, applicants must establish clearances as described in [California Public Resource Code \(P.R.C.\) Division , "Forests, Forestry and Range and Forage Lands," Part 2, Chapter , Section 292](#). PG&E can exempt applicants if the vegetation around power poles at the completed construction site will be well irrigated, low growing, and not highly flammable in perpetuity. In general, do not plant trees near power poles or towers.
- B. For electric distribution, low-voltage and high-voltage lines rated up to 60,000 volts, applicants must establish a 1-foot "low-growth" zone on both sides of all new lines. Applicants also must ensure that all branches with potential overhang within feet of the conductors are trimmed.

Applicants must not plant trees under or within 1 feet of distribution power poles. Applicants should landscape with low-growth, fire-resistant plants, shrubs, and flowers in the zone under electric power lines. PG&E recommends planting shrubs and flowers in low-growth zones to ensure compliance. Figure - 0, "Illustration of 1-Foot Clearance, Low-Growth Zone," on Page -28, and Figure - 1, "Grass and Shrubs Recommended Under Service Lines," on Page -29, illustrate low-growth zones and show how the 1-foot clearance is measured from the center of the pole.

- C. For all electric transmission, high-voltage lines rated greater than 60,000 volts, applicants must not plant trees within the right-of-way easement of the transmission poles or towers. Applicants must follow a "no-growth" zone inside rights-of-way areas, including under the electric power lines. The zone outside the rights-of-way areas is a "low-growth" zone, tree-planting zone, and/or a shrub-and-flower planting zone. Figure - 1, "Grass and Shrubs Recommended Under Transmission Lines," on Page -29, illustrates a no-growth zone.

.10.1. (continued)

- D. Applicants must ensure that a thorough inspection is made of proposed construction areas. Dead, dying, diseased, or hazard trees tall enough to fall into the proposed power lines must be removed. Hazard trees are defined as any tree having a structural defect that may cause the tree, or a portion of the tree, to fall either on someone or on something of value.

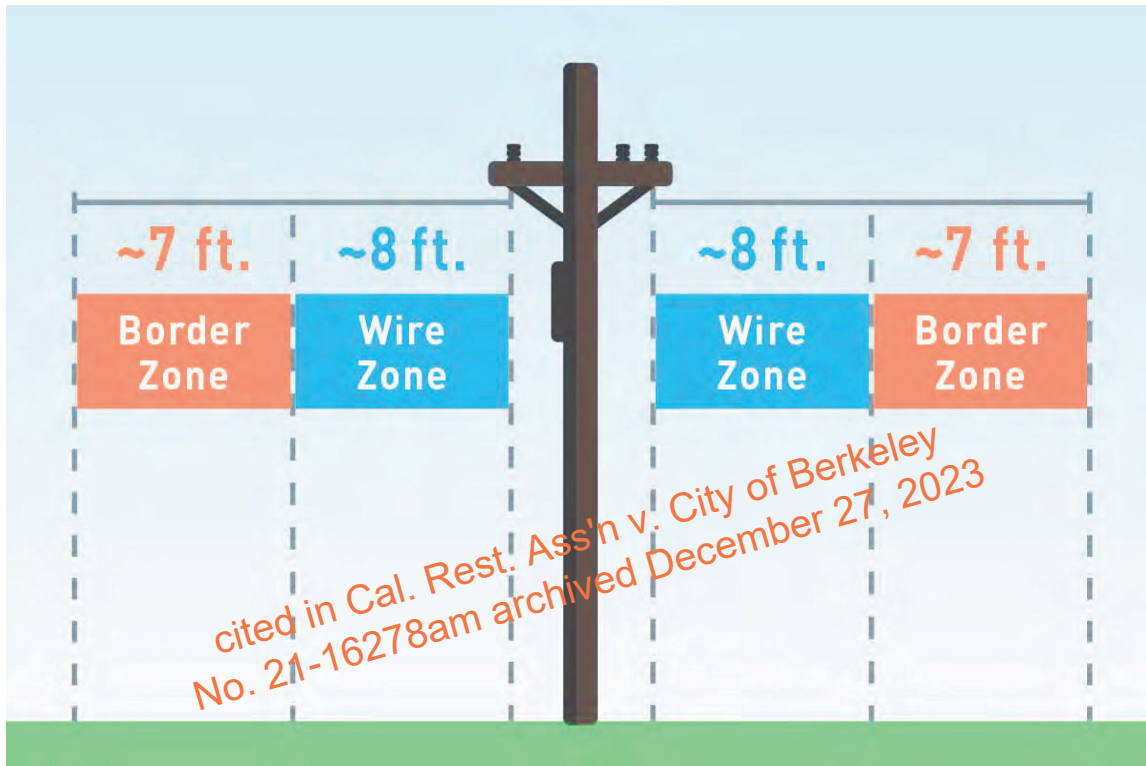


Figure - 0  
 Illustration of a 1 -Foot Clearance, o -Gro th one

.10.1. (continued)

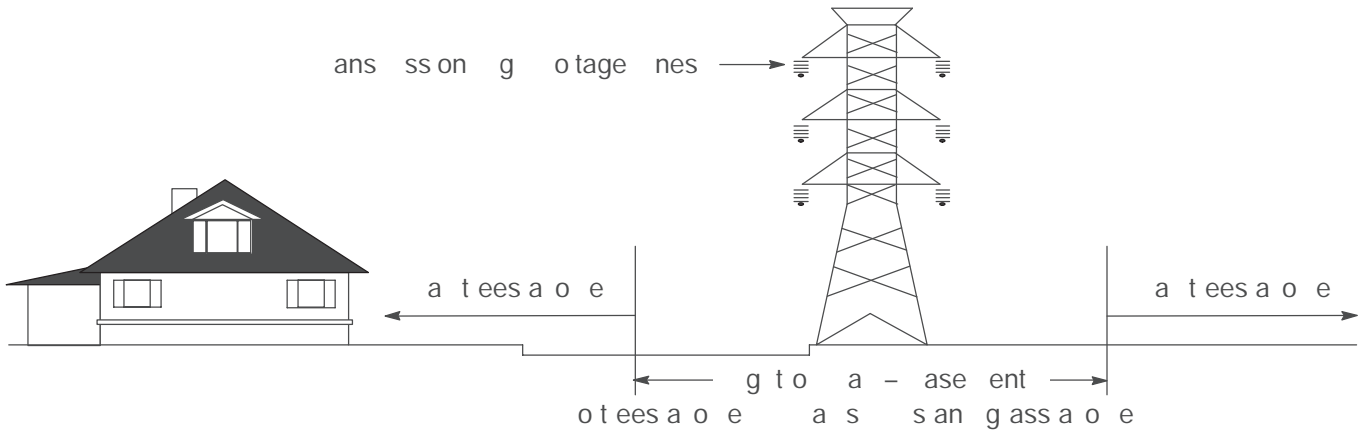


Figure - 1  
Grass and Shrubs Recommended Under Transmission Lines

E. Applicants can contact PG&E’s vegetation management personnel to obtain more information about codes or regulations and to schedule field inspections for construction sites. Vegetation management personnel perform field inspections to identify clearance requirements or hazard trees.

10.2 Planning Requirements

When planning and routing, high-voltage, overhead electric lines, applicants must avoid areas with heavy tree growth. See the tree-planting matrix tables (Tables B-1 through B- starting on Page B-2) in [Appendix B, “Electric and Gas Service Documents.”](#) Building plans should indicate where overhead lines pass within the boundaries of the construction and landscape areas, as shown in Figure - 0, “Illustration of a 1 -Foot Clearance, Low-Growth one,” on Page -28, and Figure - 2, “Alternative routes to a house Showing high-voltage lines and Tree-Clearance ones,” on Page - 0.



.10.2. (continued)

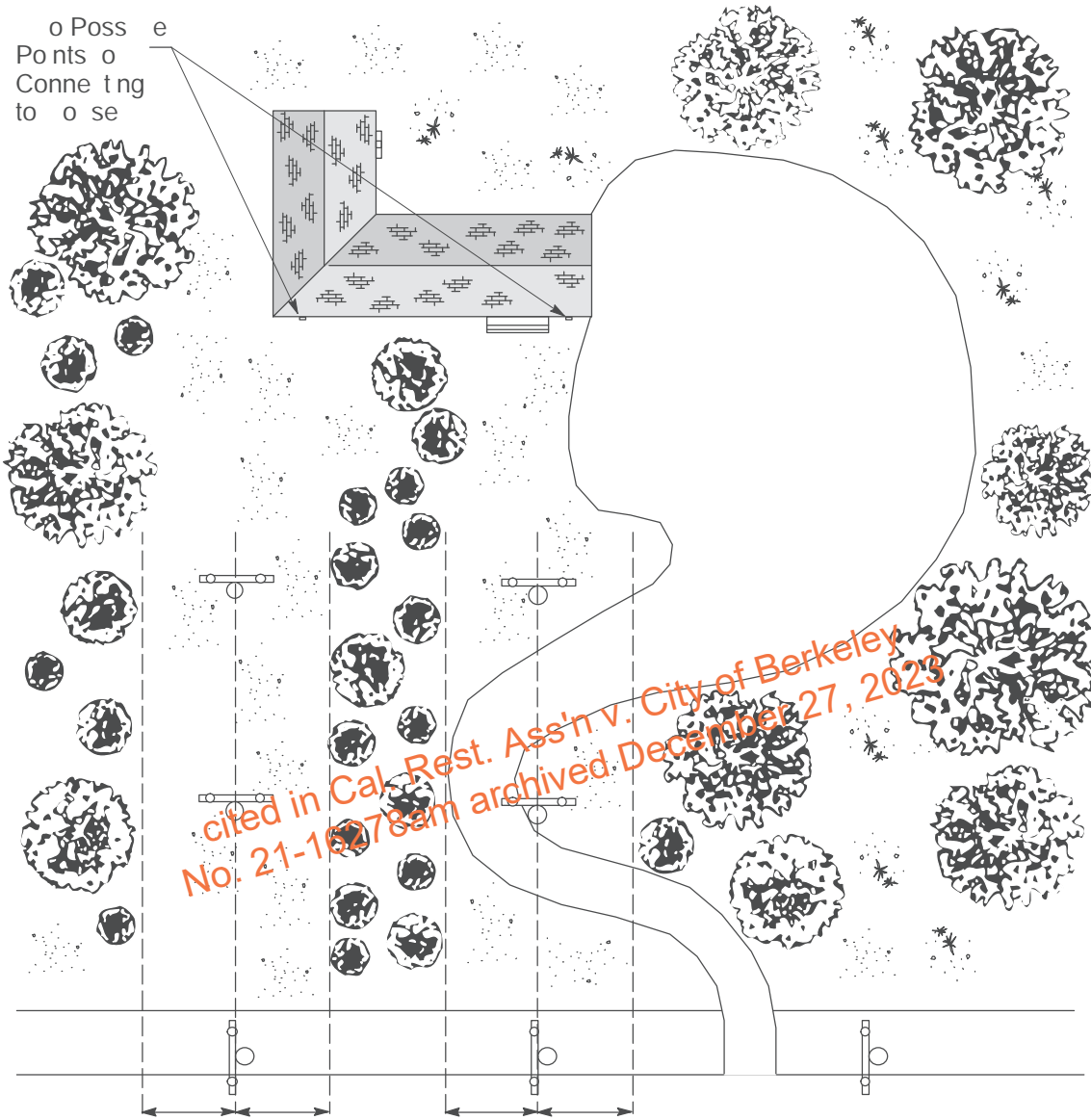


Figure - 2  
Alternative Routes to a House Showing High-Voltage Lines and Tree-Clearance Zones

10 Existing Overhead Lines Adjacent to Developments

Most new developments are designed to ensure that power lines are built underground. However, one or more sides of the construction area may be bordered by existing power lines. When planning landscape improvements, applicants must use only lower-growing, fire-resistant plant species under and near overhead electric lines.

## 10 Line Extensions

Line extensions must be constructed with a 1-foot clearance on either side of high-voltage power poles. This includes removing any overhanging branches. Applicants must clear the area from one end of the line extension to the final connection point before construction on the line extension begins.

Figure - 2 on Page - 0 illustrates an approved method for clearing affected areas. Also, any hazard trees identified during the PG&E inspection that are located outside of the 1-foot clearance zone on either side of the power poles should be removed before construction begins on the line extension. PG&E will not connect new lines to the existing distribution system until the applicant provides adequate clearance from the trees.

## 10 Primary Overhead Distribution Poles in Commercial Orchard Installations

Applicants must not plant trees under or adjacent to primary overhead distribution lines. When discovering any new tree plantings, PG&E reserves the right to remove those trees in order to protect its facilities.

Applicants must work with the PG&E project coordinator to choose a route for the overhead distribution facilities that does not conflict with the orchard trees and eliminates the need for future vegetation pruning.

When planting near overhead electrical service drops, applicants must consider both safety and access to the electric facilities when irrigation pumps and other electrical loads require repair.

## 10 Removing Vegetation Near Existing, High-Voltage, Energized Lines



## CAUTION

Because safety is the Company's highest priority, the [California Occupational Safety and Health Administration \(Cal OSHA\)](#) requires that all vehicles, equipment, tools, and people maintain a minimum 10-foot distance from all high-voltage power lines. Refer to [Section 1, General, Table 1-2, Minimum Safe Working Distances \(Scale, Equipment, Tools, Structures, and People\)](#), on Page 1-11, and [Table 1-3, Minimum Safe Working Distances \(Boom-Type Lifting or Hoisting Equipment\)](#), on Page 1-12, for the minimum safe working distances.

Applicants or unqualified tree-trimming contractors should never attempt to trim or remove trees that are within 10 feet of high-voltage power lines (i.e., conductors).

If it is necessary to trim or remove trees located within 10 feet of a high-voltage power line, applicants must notify PG&E at 1-800-743-5000.

Generally, high-voltage power lines are any overhead lines that connect from pole to pole. These lines typically are 600 volts and greater. Post a "HIGH

VOLTAGE" sign on the poles or crossarms, as shown in Figure - , "High-Voltage Marker on Poles and Crossarms," on Page - 2.

.10.6. (continued)

However, applicants should contact PG&E for assistance if a line’s voltage is unknown, and should always assume that lines are high voltage.

During PG&E’s normal tree-trimming schedule, contractors qualified to perform high-voltage line clearances will prune or remove trees at no cost to applicants to create a safe distance between the vegetation and high-voltage power lines.

If it is necessary to trim a tree that is closer than 10 feet from an overhead power line before PG&E’s normal tree-trimming schedule, applicants may hire a qualified tree company to perform high-voltage line clearances (i.e., prune trees to a safe distance away from the electric lines). Again, unqualified companies employees must never perform high-voltage line clearances. Applicants can contact PG&E to obtain the tree-trimming schedules for their areas.

There are regulations and statutes that dictate the requirements for working around high-voltage power lines. The [California Occupational Safety and Health Administration \(Cal/OSHA\)](#) requires that persons working within certain distances of overhead power lines be qualified and trained properly. For details, see the California Code of Regulations, Title 8, Division 1, Chapter , Subchapter , Group 2, “High-voltage Electrical Safety Orders,” [Article , Provisions for Preventing Accidents Due to Proximity to Overhead Lines.](#) and [Article 8 “Line Clearance Tree Trimming Operations.”](#)

In addition, the [California Penal Code](#) makes it a crime for any person to work within 6 feet of a high-voltage power line. For details and additional information about this misdemeanor, see the [California Penal Code, Part 1, “Of Crimes and Punishments,” Title 10, “Of Crimes Against the Public Health and Safety,” Section 8 \(b\).](#)

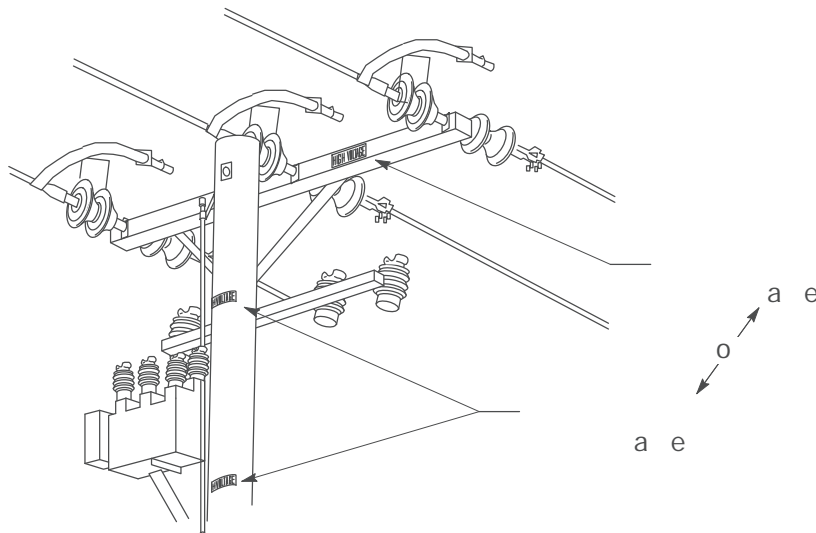


Figure - High-voltage Marker on Poles and Crossarms

.10.6. (continued)

See [Appendix B](#) for PG&E's Community Wildfire Safety Program brochure, Guide to Landscaping in High Fire-Threat Areas (on Pages B-2 and B-3). This brochure suggests the best low-growing, fire-resistant native vegetation to use when planting near power lines. In general, select plants with a reduced risk for starting and fueling wildfires.

- Low-growing native vegetation
- Plants with high-moisture and low-resin content
- Well-watered vegetation
- Plants that do not create or accumulate dry, dead material

Many people now consider non-vegetative landscaping, including the following ignition-resistant options.

- Sand
- Decorative gravel
- Tumbled glass
- Drainage rock
- Beach pebbles
- Mulch, wood chips, bark

*cited in Cal. Rest. Ass'n v. City of Berkeley  
No. 21-16278am archived December 27, 2023*

This Page Intentionally Left Blank

*cited in Cal. Rest. Ass'n v. City of Berkeley  
No. 21-16278am archived December 27, 2023*

SECTION  
ELECTRIC METERING:  
GENER

*cited in Cal. Rest. Ass'n v. City of Berkeley  
No. 21-16278am archived December 27, 2023*

SECTION ELECTRIC METERING: GENER

SECTION ELECTRIC METERING: GENER

*cited in Cal. Rest. Ass'n v. City of Berkeley  
No. 21-16278am archived December 27, 2023*

## Section Electric Metering: General

---

### 1 Scope

This section of the manual is designed to help applicants, engineers, and contractors plan acceptable electric metering installations for the electric service supplied by Pacific Gas and Electric Company (PG&E/Company). The information and requirements described are applicable to [Section 6, “Electric Metering: Residential,”](#) through [Section 11, “Electric Switchboards: 601 volts Through 2,000 volts, and Primary Services.”](#)

For help with determining the service rating of customer equipment, see Subsection 1.1 located on Page 1-1.

NOTE: See new service and current transformer (CT) installation requirements in Subsection 2.2, “Requirements for the Installation of Secondary Terminations (0–600 volt) in Metering Equipment Requiring CTs,” on Page - .

### 2 General Conditions and Responsibilities

#### 2.1 Approved Metering and Service Termination Equipment

All service termination and metering equipment must conform to nationally recognized standards, meet all applicable certification requirements, and bear the certification marking of a nationally recognized testing laboratory. Nationally recognized standard organizations include, but are not limited to, the following: [National Fire Protection Association \(NFPA\)](#), [National Electrical Manufacturers Association \(NEMA\)](#), [Underwriters Laboratories \(UL\)](#), and the [Occupational Safety & Health Administration’s \(OSHA’s\) Nationally Recognized Testing Laboratory \(NRTL\) Program](#). The equipment also must meet the requirements specified in the [Electric Utility Service Equipment Requirements Committee \(EUSC\) manual](#) and be approved by PG&E for use in construction projects.

NOTE: Employees perform an onsite field inspection of the equipment and installation and provide final approval only after ensuring that all of the specified requirements have been met.

#### 2.2 Drawing Submittal Requirements for Metering and Service Termination Equipment

Applicants must meet the requirements in Item A., through Item E., both on Page -2, when installing electric metering and service termination equipment. This applies to residential and nonresidential applications and includes meter panels, pedestals, panelboards, and switchboards that are wall-mounted, pad-mounted, pole-mounted, or on panelboard construction.



.2.2. (continued)

- A. Submit drawings for metering equipment to PG&E using either hard-copy paper drawings (in triplicate) or electronic files. Drawings must be reviewed and pre-approved either by local meter shop employees or by a meter specialist.
- B. Submit drawings for metering equipment to PG&E with the following current ratings. Do not submit drawings for metering equipment rated less than described below unless PG&E requests them.
1. Single-family Residential
    - all-mounted and pad-mounted (floor standing): Current ratings of 20 amps or above.
  2. Multi-family Residential
    - all-mounted and pad-mounted (floor standing): Current ratings of 20 amps or above.
    - Pedestals (pad-mounted): Current ratings of 200 amps or above.
  3. Nonresidential Commercial and Industrial
    - all-mounted and pad-mounted (floor standing): Current ratings of 100 amps or above.
    - Pedestals (pad-mounted): Current ratings of 100 amps or above.
  4. Nonresidential Agricultural
    - Pole-mounted, panelboard construction, and wall-mounted: Current ratings of 200 amps or above. A single-line drawing also must be submitted showing the fuse size, circuit breaker, and main disconnecting device ratings for all of the equipment being installed.
    - Pad-mounted (floor standing): Current ratings of 100 amps or above.
- C. Also, submit drawings for newly designed metering equipment or for equipment that has been modified from existing designs as shown in the Greenbook or E SE C manuals. This applies to metering equipment of any current rating. This includes, but is not limited to, new electric equipment containing electrical devices or components for customer generation interconnections. Drawings must be sent to the Meter Engineering Department for review. The review process could take 6 months or longer.
- D. Ensure that submittals contain specific references from either the E SE C manual, this Electric and Gas Service Requirements (Greenbook) manual, or both. When using Greenbook references, include the applicable subsection(s), figure(s), and page number(s). For E SE C references, use the drawing and sheet numbers.
- E. Ensure that submittals contain specific references for each component or section included with the equipment. Provide a detailed summary of the specification information in the beginning of the submittal, as well as on all equipment figure drawings in the submittal.

## 2 Applicant Responsibilities

The applicant must provide, install, own, and maintain the following equipment and structures listed in Item .2. .A. through Item .2. .G., starting below.

- A. All meter sockets and enclosures, metering transformer cabinets, and switchboard service sections intended for utility use, unless PG&E permits a specific exception.
- B. Use only ring-type meter sockets, enclosures, switchboards, and other metering equipment approved both by PG&E and [E SE C](#).
- C. For Overhead Service: Overhead meter panel, service entrance conductors, conduit, and a weatherhead to the point of attachment to PG&E's overhead service conductors.
- D. For Current-Transformer Panels and Switchboards: Pull boxes, an underground service-termination pull box, and a separate current-transformer cabinet and meter box.
- E. All Indoor Meter Panels: Individual, residential, or nonresidential applicants with a meter-panel rating of any size, installed inside a meter room or inside a building or other type of structure, must follow all of the requirements described below.
  1. Install, own, and maintain a separate nominal, 2-inch diameter conduit with pull tape inside. The conduit and pull tape must extend from the meter panel or switchboard and terminate in a [EMA](#) , 6-inch x 6-inch x 6-inch enclosure located 8 feet to 10 feet above grade on the outside surface of the building.
  2. Follow the applicable requirements in [umbered Document 09 68](#) , "Smart Meter Electric Network Requirements for Indoor Meter Rooms and High-Rise Buildings," located in [Appendix C, "Electric and Gas Engineering Documents."](#)
  3. Do not use the conduit. The conduit is for PG&E's metering equipment only. See additional requirements in Item .2. .G. on Page - .
- F. All Indoor or Outdoor Meter Panels: Individual, nonresidential applicants with a meter-panel rating of 500 or greater must install, own, and maintain a separate, nominal, 1 2-inch diameter conduit with pull tape inside. The conduit and pull tape must extend from the telephone service location and terminate in a horizontal position on top of the meter panel section, 6 inches to 12 inches from the front of the meter panel. The conduit must not enter or pass through the switchboard or switchgear. Do not cut or penetrate the top of the electric panel or switchboard.

cited in Cal. Res. Ass'n v. City of Berkeley  
No. 24-16278am allowed December 27, 2023

.2. . (continued)

**EXCEPTION:** Approved meter-panel locations that have adequate wireless radio frequency (RF) signal capabilities may be exempted from installing the 1/2-inch phone line conduit. To request a variance, customers must submit switchboard and meter-panel drawings with the jobsite address to their local project coordinator early in the service application process. The project coordinator submits this information to the PG&E local meter shop, enabling PG&E employees to make a field determination as to whether or not the conduit should be required.

Without an exemption from the meter shop, the 1/2-inch conduit is required and must be installed.

**NOTE:** A 00 kV minimum, 3-phase (Ø) meter panel is defined as one of the following:

- 240 / 80 volts, 3-wire wye, and minimum 800 amps
- 120/208 volts, 3-wire wye, and minimum 1,600 amps
- 120/240 volts, 3-wire delta, and minimum 1,600 amps
- 120/240 volts, 3-wire delta, and minimum 1,600 amps
- 2,400 - 21,000 volts, primary service, any size

G. Conduit installed in the ground, floors, ceilings, walls, or concrete must be made of rigid steel. In any other installation location, the conduit type can be electrical metallic tubing (EMT) or better. For underground installations, the conduit must exit the pad on the outside of the switchgear...not inside the switchgear. See Figure 1-6, "Preferred Location of Conduits for Indoor and Outdoor Meter Panels and Switchboards," on Page 1-20.

H. For recommendations on the best locations for equipment, ask your project coordinator to contact PG&E's electric metering department. Questions may include the prime location for a phone interface box, the required point for conduit to exit the meter room or building, or your options in a remote location when a telephone line is unavailable.

I. Transformers rated at 120/240 volts, three-phase, 3-wire, with delta-connected service installed, must have the "high leg" (e.g., power leg, stinger leg) conductor located either in the center phase or on the right phase position. This conductor usually is designated as the "C" phase for metering purposes. Mark (i.e., identify) the conductor (e.g., high leg, power leg, stinger leg) properly. The color orange is typically used for this purpose.

On all self-contained services, the power leg must be located in the far-right phase position, usually designated as the "C" phase. Mark (i.e., identify) the conductor (e.g., high leg, power leg, stinger leg) properly. The color orange is typically used for this purpose.

J. Applicant wiring that extends from the distribution section (i.e., branch circuits) must not pass through any PG&E-sealed section.

.2. . (continued)

- . Single-metered applicants with single-phase services above 00 amps should consider installing a switchboard as described in [Section 10, “Electric Switchboards: 0 olts Through 600 olts.”](#)
- . For nderground Service: Conduit and electric meter panel manufactured for PG&E’s underground service conductors.

## 2 Re uirements for Installing Secondary Terminations (0– 00 olts) in Metering E uipment Re uiring CTs

All non-PG&E personnel (e.g., applicant installers) who install, inspect, or supervise the installation of PG&E services, and all PG&E personnel who schedule, install, inspect, or supervise the installation of services and metering work, must follow the new construction requirements for installing secondary terminations at customer switchboards or meter panels when 600 metering CTs have not been installed.

on-PG&E personnel installing approved PG&E service-entrance conductors must contact the local PG&E project coordinator and request that the CTs be installed before the service-entrance conductors are installed (usually 1–2 weeks before).

To ensure the safety of field metering personnel, CTs must be installed on new services before the service conductors are terminated in the utility pull section. To prevent the secondary voltage from being energized inadvertently before the CTs are installed, all personnel should know and follow the safety requirements for installing secondary terminations.

refer to the following PG&E documents for detailed instructions about installing secondary terminations (0–600 volt) in metering equipment requiring CTs:

- [TD-2 2 P-01, “Distribution Transformer Operations”](#)
- [TD-6 01P-01, “Electric Metering Safe ork Procedures,” Attachment 1, “Installing 600 olts Current Transformers”](#)

## 2 1 PG&E s Responsibilities

PG&E provides, installs, owns, and maintains all meters and metering transformers for full-service applicants. For direct access applicants, refer to [Direct ccess Standards for Metering and Meter Data \(D SMMD\) in California](#) (March 1999).

## Electric Meters: General ocation Re uirements

To determine the most satisfactory meter location and to ensure that adequate space is provided for the meter, consult a PG&E project coordinator in the project’s preliminary planning stage. All equipment clearance and working space requirements must be met.

. . (continued)

When an electric panel is being relocated or replaced, and PG&E's existing service conductor will be used, as determined by PG&E, the panel must be positioned so the service conductor can be reconnected properly. The existing service conductor must be able to be reconnected to the underground electric panel termination lugs or the external service-entrance conductors coming out of the weatherhead for overhead services. If PG&E needs to install additional service conductors or cables to perform the reconnect, the work and material would be at the applicant's expense. PG&E does not accept cable-termination techniques using pin adaptors, cable ringing, or splicing on additional cable.

The local PG&E meter shop must approve remote meter locations before applicants locate meters away from (i.e., remote from) termination enclosures. Applicants must submit a drawing that shows the distance (in feet) and the accessible path to the remote meter location. Also, describe the size and type of conduit used to attach to the remote meter.

See [Section 6, Figure 6- . "Typical Underground, Separate-Based, Current-Transformer Cabinet and Safety-Socket Meter Box Assembly, 201 Amps– 00 Amps, Ø and 201 Amps–800 Amps, 1Ø,"](#) on Page 6-8, as an example of remote metering.

Applicants can avoid the time and expense of installing additional facilities or relocating existing facilities by consulting with PG&E early in the process.

#### 1 Basic Meter Location Requirements

The following five lettered items explain PG&E's basic meter location requirements and are subject to PG&E's review and approval to ensure compliance. Applicants must ensure that:

- A. Locations have at least one clear and unobstructed path or entrance providing access to the working space.
- B. Portable illumination is provided for the working spaces around meters, metering-related equipment, and associated facilities when meters are located indoors. Also, applicants must provide a hallway or aisle leading to the meter(s) and metering equipment.
- C. Locations in elevated areas (e.g., balconies or mezzanines) or in depressed areas (e.g., basements, cellars, or underground rooms) must be accessible by either a ramp or clear stairway that conforms to building-code requirements.
- D. PG&E has provided advanced approval when potential locations are not in conflict with prohibited meter locations and are on walkways, alleys, or driveways that provide access to commercial or industrial property. PG&E may grant exceptions if other suitable locations are not available.

## . .1. (continued)

E. PG&E personnel have full access to inspect, read, or test metering facilities, whether the facilities are located indoors or outdoors. Applicants must ensure that all metering and service facilities are accessible and free of obstacles at all times when the metering equipment is energized. Applicants must maintain these accesses both during and after landscaping activities, fence installations, building construction, building renovation, remodeling activities, etc.

## 2 Prohibited Meter and Service Equipment Locations

The following locations are not acceptable for electric meters and service termination equipment.

- A. Locations deemed hazardous to either personnel or equipment, or locations found to be unsuitable for entry. These locations include:
1. Inside any residence.
  2. Directly over any stairway, ramp, or steps.
    - . Any area where personnel may contact either exposed, high-voltage conductors or equipment in motion.
    - . Any area that is accessible only through a trapdoor.
    - . Any elevator shaft.
  6. Any doorway, hatchway, or drive-through pathway designed for picking up goods through a window, where opening the meter panel blocks the through-area.
  7. Areas where entry may be restricted or controlled because of medical, health, environmental, or other safety-related issues.
  8. Any area in close proximity to a lake or water area. These locations are unsuitable when the meter faces the water.
  9. In traffic medians or areas where there is traffic on both sides of the meter.
  10. Any indoor or outdoor area where personal protection equipment is needed, as determined by PG&E, including eye and hearing protection.
  11. Outdoor areas less than 100 feet away from biowaste, toxic, corrosive, or a similar-type of unsafe substances that could be released into the air, are found in the ground soil, are located in open-air wet ponds, or are stored in dry locations.
- B. Underground vaults or enclosures.
- C. Areas where vibration, moisture, excessive temperature, fumes, or dust may damage the meter or interfere with its operation.
- D. Areas within or requiring access through any restroom, bathroom, shower, powder room, toilet, or private-type room.
- E. Portions of buildings where landscaping, fencing, or other construction activities will make the meter inaccessible.

*cited in Cal. Res. Ass'n v. City of Berkeley  
No. 21-16278am filed December 27, 2023*

. .2. (continued)

- F. Inside any single-family residence, multi-residential, or nonresidential building, garage, or structure that does not meet all of the requirements described in Subsection . . . , “Electric Meter and Service Termination Equipment Rooms,” on Page -8.
- G. In a metallic cabinet (including doors), room, enclosure, or location that blocks or interferes with the radio frequency signal transmissions that are necessary for PG&E to operate its SmartMeter™ Advanced Meter Reading system. This applies only to meter panels that meet all of the following criteria.
  - Single metered
  - Less than 100 amps continuous rating
  - Wall mounted
- H. In a room, utility closet, or area where metering facilities or termination enclosures are less than 6 feet away from any water source such as pipes, valves, fire sprinklers or equipment, or other wet facility.

#### Locating and Grouping Multiple Meters

When it is practical, PG&E will supply two or more meters from one service and will group the meters at one location. Also, see [Section 2, “Gas Service,” Subsection 2, “Multiple Buildings Located on One Lot,”](#) on Page 2-1 , and [Section 2, “Electric Service: Underground,” Subsection 2, “Installing Overhead and Underground Service for Two or More Buildings on One Lot,”](#) on Page -6.

#### Electric Meter and Service Termination Equipment Rooms

PG&E prefers to install electric service and metering equipment outdoors.

When outdoor locations are not feasible, PG&E allows applicants to design and build electric rooms indoors for the meter and service termination equipment.

Applicants must ensure that meter and service equipment rooms (electric rooms) meet the following requirements. Also, see Figure -1, “Allowable Locations for Electric Service and Meter Rooms,” on Page -11, for acceptable and unacceptable room locations. If electric rooms cannot be designed and built to meet these requirements, then the service termination and metering equipment must be installed outdoors in a location acceptable to PG&E.

If meters are located in a closet, applicants must meet the requirements described in Item A through Item . . . , starting below.

- A. Electric room locations and specifications must be approved during the initial stages of construction. Submit the following sets of drawings listed below. Drawings should be labeled and marked to help with the review. Drawings must be submitted to your local project coordinator for review by the local meter shop.

. . . (continued)

1. **Building site plans** Shows where the electric room is located, including driving and walking paths to the room.
2. **Elevation plans (all sides)** Shows where the room is located, including access and walking paths to the room, and any ramps and driveways leading to the room.
  - . **Floor plan** Shows the dimensions of the room, all service and metering equipment to be installed (including fire pumps), and the working space and clearances surrounding all of the equipment.
  - . **Single-line drawings** Shows the service termination and metering equipment, fire pump switchboard or panel, transfer switches, customer generation interconnections, disconnect switches, as well as the electrical capacities and voltages of the equipment.
- B. Designs must include a designated room for electric service, meters, and metering equipment.
- C. Electric rooms must be clear of obstructions and located inside of buildings on the ground floor or no more than one story below the ground floor. The exception is a qualified high-rise building where the walking surface of the highest tenant-occupied floor is over feet high. PG&E may, at its option, approve grouped meter locations on one or more upper floors.
 

For high-rise buildings, typically 16 stories or greater, PG&E at its discretion might allow subtractive billing for locations that qualify and meet the requirements. Contact your local service planning representative for more information.
- D. Electric rooms must have a doorway that opens 90 degrees or more directly to the outside of the building or into an area that is available to the general public. DO NOT design and build meter and service-termination rooms with multiple separate doorways leading up to the room or which must be accessed by walking down a corridor.
 

NOTE: The term “available to the public” means any person(s) who does or does not live or work at the location can walk into the business, building, or structure and up to the meter room without being restricted by locked doors, gates, security personnel, or other forms of restriction.
- E. Electric rooms must have a clear and safe working space as described in Subsection . . . , “Working Space,” on Page -1 , and Subsection . . . , “Barricades,” on Page -21.
- F. Rooms must not include gas meters but can be used for communication equipment.



. . . (continued)

G. Rooms may be locked if the applicant provides PG&E with independent access to the room. Ensure the meter room is locked using one of the following methods.

1. Preferred: Use an acceptably located key lock box, provided by PG&E and installed by the applicant, to hold the applicant's key to the electric meter room door. The key's lock box must be installed near the meter room door. PG&E personnel can use the following meter codes to order a key lock box for an applicant:

- M1 016
- M1 01 1
- M2 109

2. Nonpreferred: Use a double-lock device (e.g., hasp), provided by the applicant, with one lock for the applicant and one lock for PG&E. This type of double-lock arrangement is typically used on gates.

Rooms must be identified by appropriately marking the doors or doorways as described in Subsection .1., "Properly Identifying and Marking Meters," on Page -2 .

I. Rooms must have conduit(s) and pull tape installed as described in Subsection .2.1 "Applicant Responsibilities," on Page -1 through Page -

The applicant must install lighting for the electric meter room. The minimum-acceptable illumination is two lights with a combined brightness of 30 foot-candles.

Rooms must be designed and constructed with a means to adequately discharge any excess water that may enter the room from the conduit system. Below-grade electrical rooms must be designed and constructed to eliminate any and all water intrusion into the room, including through the service entrance conduit system.

The meter and service-termination (electric) room must be designed and constructed to include an outer wall of the buildings to meet the following requirements.

1. The PG&E service must be installed from the outside directly into an electric room and may not run under other rooms or spaces in the building before reaching the meter and service termination room.
2. The PG&E service must not extend more than 20 feet past the building's outer foundation into an electric room.
3. The room must have a doorway that opens 90 degrees or more and leads directly to the outside of the building.

. . . (continued)

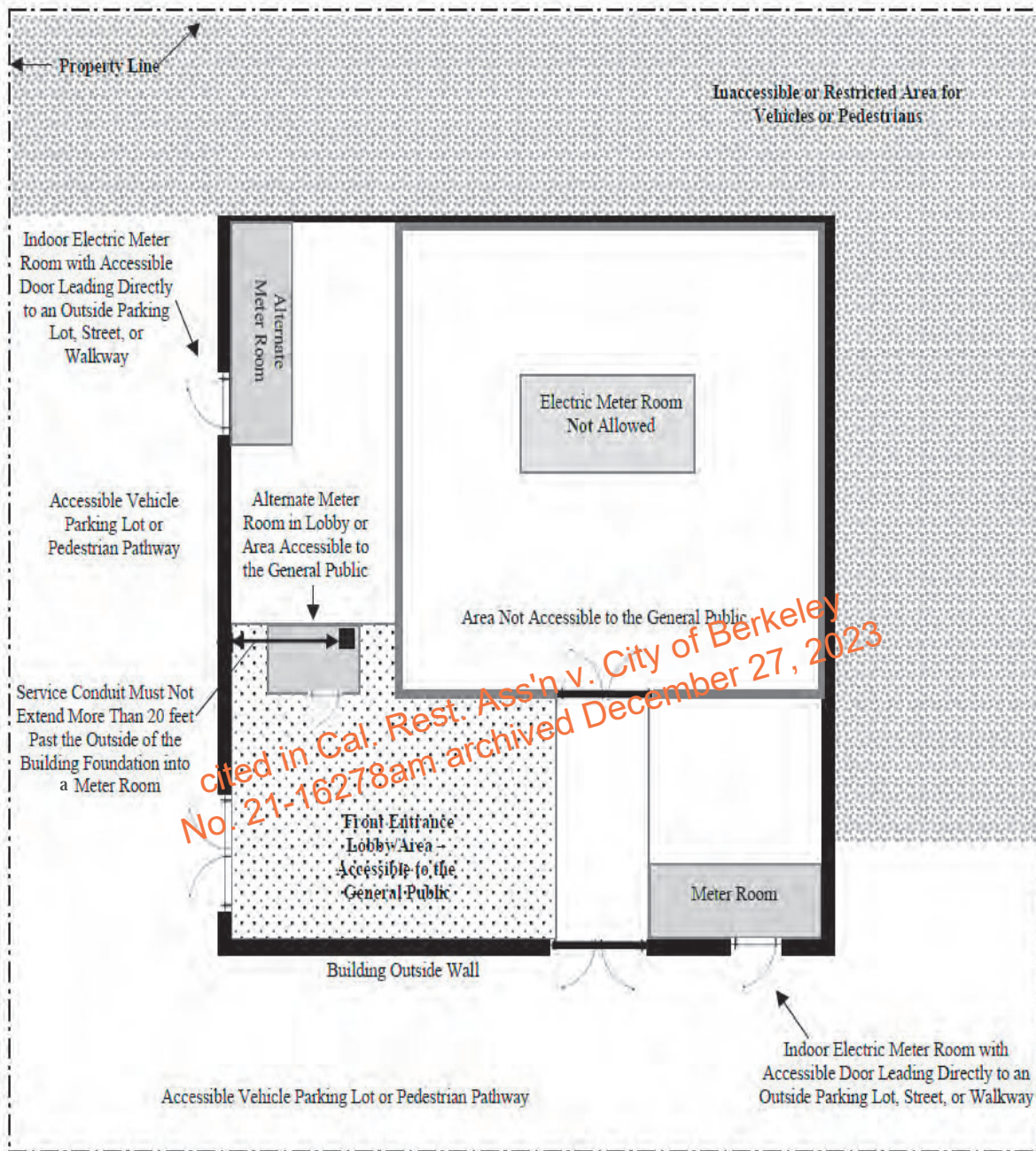


Figure -1  
Allowable Locations for Electric Service and Meter Rooms

. . . (continued)

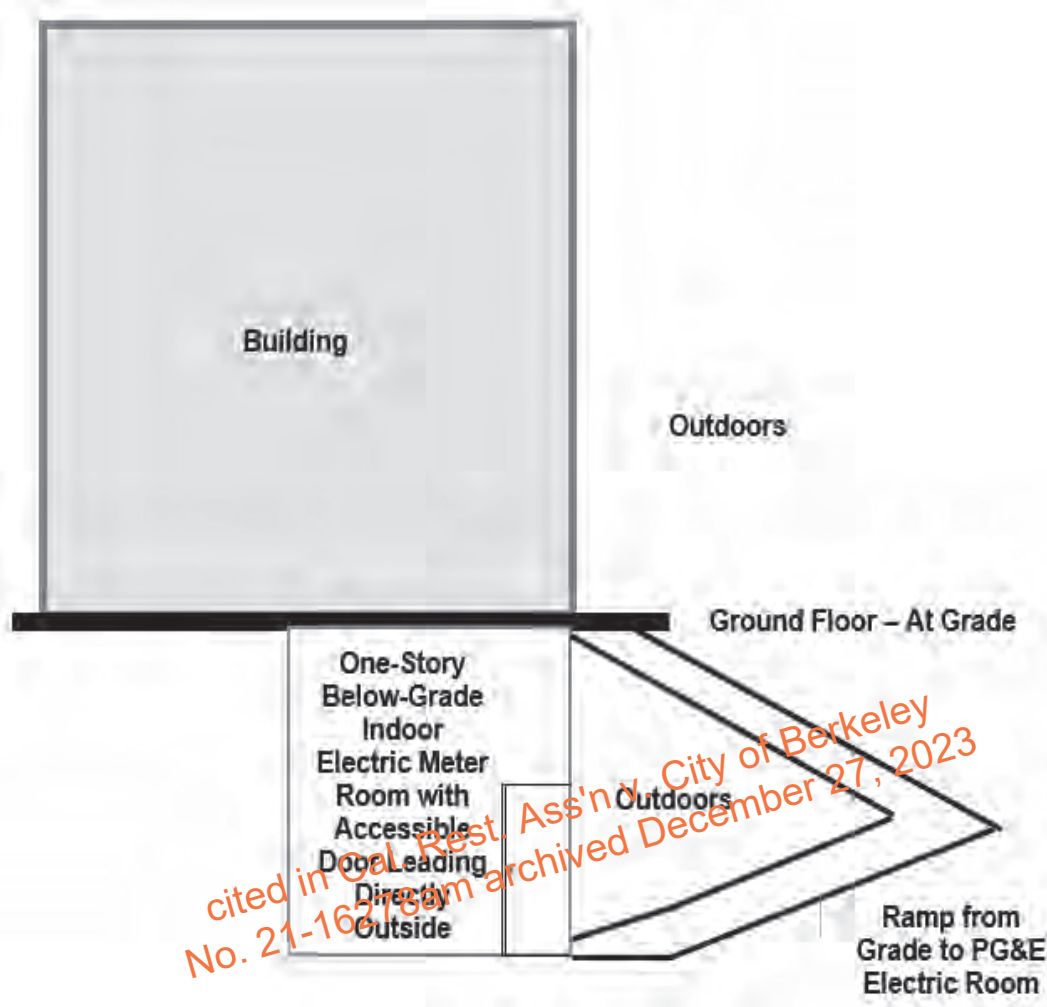


Figure -1 Detail  
Outdoor Ramp to Electric Service and Meter Room below Grade

Notes in reference to Figure -1 and Detail A.

1. If the electric rooms are located below grade, then the applicant must ensure that an accessible, permanent, and unrestricted walking ramp is provided starting at grade outside of the building and continuing directly to the meter-room door. Additional doors or gates are not allowed along the walking ramp between the outside and the meter room door. PG&E personnel may need to roll heavy equipment into and out of the meter room, so stairs are prohibited.
  2. If the electric meter room(s) is located inside a vehicle garage area, either at grade or below grade, and has building entrance gates or locked doors, then the applicant must ensure that the building is accessible to PG&E through a driveway entrance into the garage that is shared with the building occupants, and PG&E is granted access to any locked entrance gates and doors. A shared garage driveway is secondary access and does not eliminate the requirements for a meter room door directly to the outside of the building or a walking ramp (see note 1 above) to a below-grade electric room.
- . Applicants must ensure that electric rooms are not located in the interior of a building connected by hallways, corridors, or other internal passages. This is not considered direct access from the electric room to the outside.

## Meter Heights, Clearances, Enclosures, and Protection

### 1 Meter Heights

#### Pole-, Pad-, and Wall-Mounted Meters

When installing meter enclosures on a pole, on a wall, or on a pad-mounted structure, applicants must ensure that the meters meet the following requirements, except when installing metering equipment on poles for communication services. In that situation, follow the requirements in Section 10.1.B on Page 10-1. All metering and service-termination facility installations are subject to PG&E review and approval. The meter height must be measured to the horizontal centerline of the meter axis.

1. PG&E's preferred meter height is 66 inches for all individual service-termination and meter-panel installations. All electric meters must be located 66 inches maximum above the ground or standing surface. The minimum meter heights are listed below.
  - Meters installed in self-contained panels rated up to 20 amps must be a minimum of 48 inches.
  - Meters installed in outdoor transformer-rated panels 100 amps and above must be a minimum of 60 inches. This applies to wall-mounted and panel board construction.
2. When meters either are enclosed in a cabinet or installed indoors in a meter room, the maximum meter height is the same as for outdoor installations, or 66 inches. The minimum meter height must be 48 inches as measured from the ground or standing surface to the centerline of the meter.
  - For switchboard service with a current transformer (CT) compartment, the maximum meter height is 72-1/2 inches, as illustrated in [Section 10, Figure 10-2, "Standard Switchboard Service Section with CT Compartment and Filler Panel, 0 volts 600 volts,"](#) on Page 10-10. This applies both to indoor and outdoor installations.
  - In locations where snow accumulates, PG&E may require the minimum installed meter height to be increased. Specific meter-height requirements depend on the meter's location. Ask your local PG&E project coordinator to consult the electric meter department for specific meter-height requirements in snow-accumulation areas.

cited in Cal. Rest. Ass'n v. City of Berkeley  
 No. 21-16278, archived December 27, 2023

## . .1. (continued)

## Communication Service and Meter Equipment

Applicants must ensure that meter panels installed for communication equipment meet all of the applicable Greenbook requirements. For metering equipment installed on poles with communication equipment, refer to the requirements specified on Page -1 .

1. Wood Pole Mounted Communication Equipment: Applicants must ensure that communication service and meter equipment installed on PG&E or joint poles is placed so the bottom of the enclosure is a minimum of 6 feet to a maximum of 8 feet from the finished grade. If it is not possible to meet the height requirements, install an electric meter pedestal. For installation requirements, ask your PG&E project coordinator for [umbered Document 02 911, "Installation Details for Service to Pole-Mounted Communication Equipment,"](#) for specific requirements.

2. Pad-Mounted Communication Equipment: When meter panels are attached to communication equipment, they must meet the minimum 8-inch meter height requirements described in Subsection . .1.A., "Pole-, Pad-, and all-Mounted Meters," on Page -1 . The upper and lower areas on the back of the meter panel must be securely attached to the equipment using all of the manufactured mounting holes. Panels that are not fully attached and secured will not be approved.

3. Steel Pole Mounted Communication Equipment: Before attaching communication equipment to PG&E-owned steel poles, review [umbered Document 09 6 7, "PG&E Metered Electric Service to Antenna and Communication Equipment on Company Owned Steel Streetlight Poles."](#) For service to municipality owned steel streetlight poles that are on a S-2 rate schedule, review [umbered Document 09 6 8, "PG&E Electric service to Antenna and Communication Equipment on Municipality Owned Steel Streetlight Poles."](#)

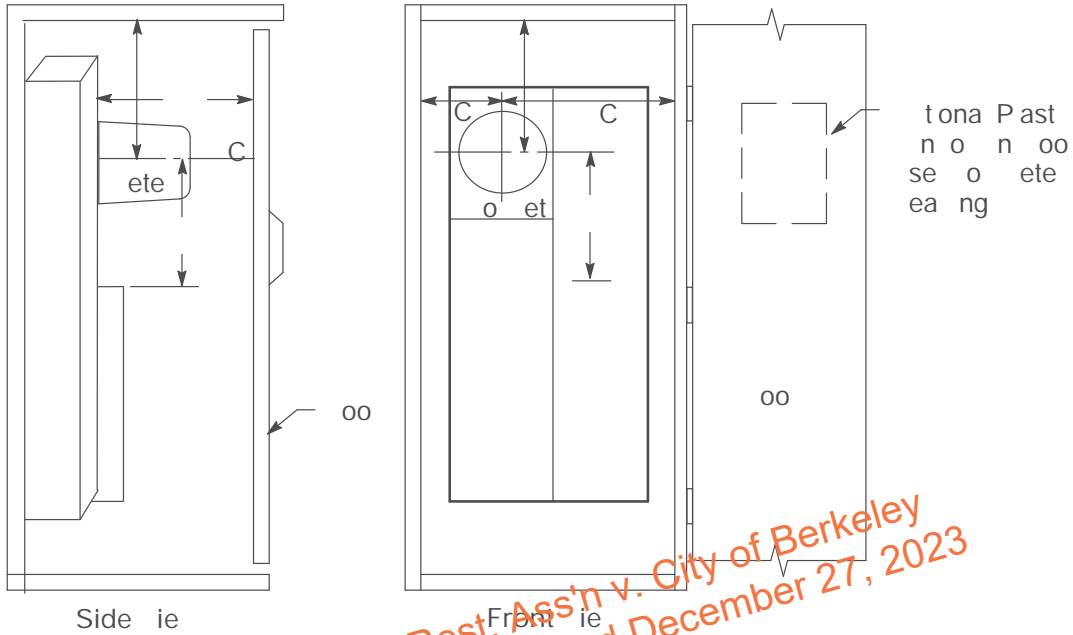
## 2 Meter Cabinet Enclosure Clearances

Applicants must ensure that meter cabinet enclosures are large enough to provide easy access to the meter and have an adequate working space for maintaining the meter. The cabinet requires a side-hinged door that can be latched open at 90° or more. Also, the enclosure and service equipment must comply with local code requirements. Detailed dimensional requirements are shown in Figure -2, "Meter Cabinet Enclosure Clearances," and Table -1, "Meter Cabinet Enclosure Clearance Dimensions," both on Page -1 .

Applicants also must ensure that meter cabinet enclosures are maintained and work properly. In corrosive areas a fiberglass enclosure is recommended to help prevent deterioration of the metallic equipment.

. .2. (continued)

Finally, applicants must ensure that when a cabinet enclosure is pad-mounted, a 3-foot clearance is maintained between the edge of the pad and the base of the pole.



*cited in Cal. Rest. Ass'n v. City of Berkeley  
No. 21-16278am archived December 27, 2023*

Side view

Front view

Figure -2

Meter Cabinet Enclosure Clearances

Table -1 Meter Cabinet Enclosure Clearance Dimensions

Dimension	n n n a ee ote eo
Dimension	n n tot ee ge o tea ess o en ng
Dimension C	n n tot ee ge o tea ess o en ng
Dimension D	n n o te ete ente ne tot e to o an ot son eo t e ete o tot e otto o t een os ng a net

e n n o enson a ee e to neson o es enta a o nte ete a net  
en os es

### Meter Set Clearance Requirements

Figure - , “Electric and Gas Meter Set Separation Dimensions and Clearances,” below, represent various metering facilities’ clearance requirements. If applicants install enclosures on their premises, the enclosures must meet the specifications provided in these illustrations.

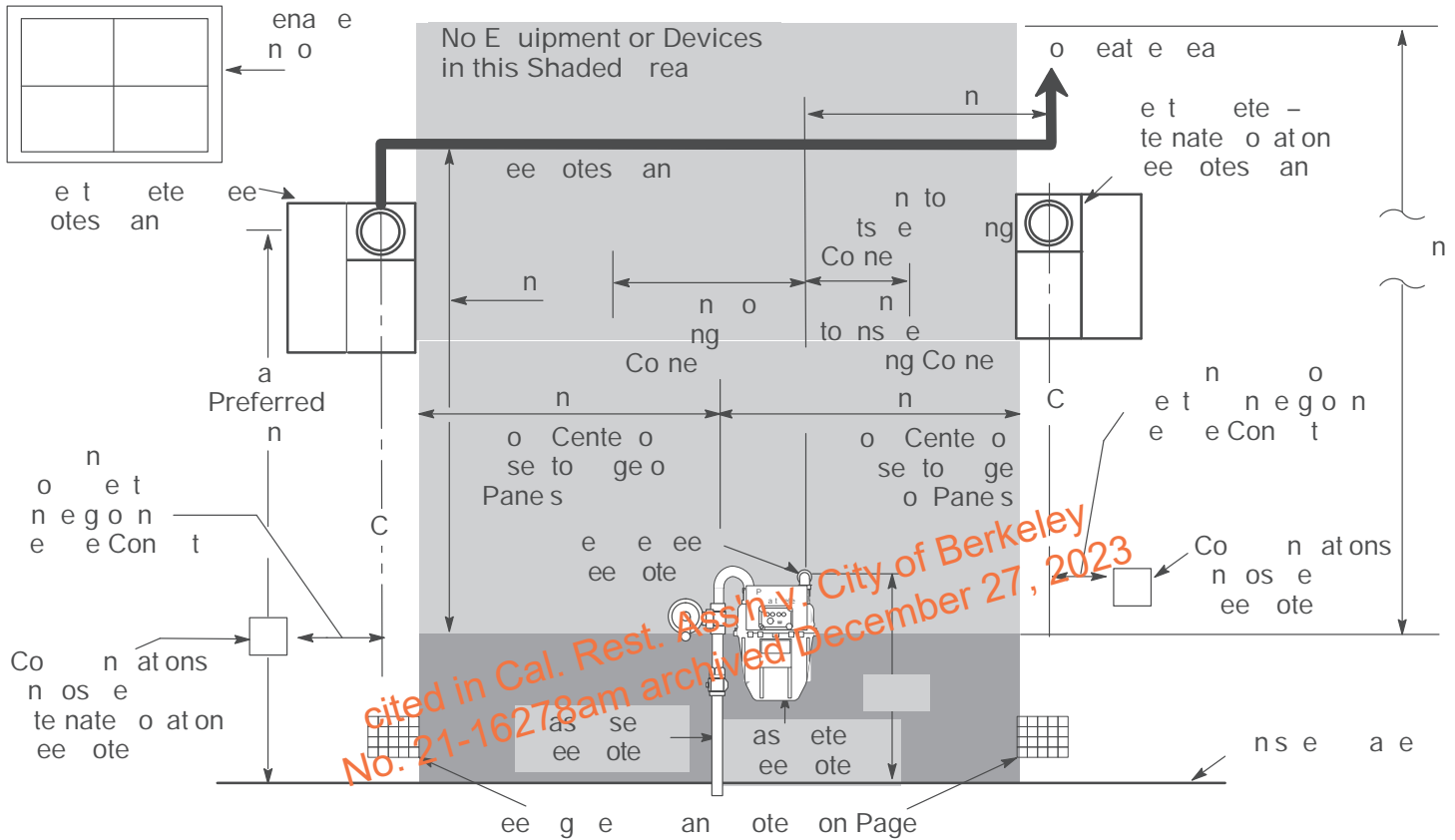


Figure -  
Electric and Gas Meter Set Separation Dimensions and Clearances

notes in reference to Figure - .

1. Electric meter-panel locations are subject to utility approval and must comply with the applicable code requirements. PG&E does not have specific requirements for the distance from the electric panel to the outside building corner. Information for properly locating the electric meters is found in this section of the manual. See Subsection . . . , “ Working Space,” on Page -1 , for electric meter working space.
  2. Applicants must not install any electrical devices or equipment, including wires, cables, metering enclosures, and telecommunication enclosures, bond wires, clamps, or ground rods within the shaded area around the gas meter. When the gas and electric meters are not enclosed in a cabinet the 6-inch clearance distance is measured from the gas meter riser. When the gas or electric meters are enclosed in cabinets, the 6-inch clearance is measured from the closest edge of the cabinet.
- . A solid and continuous metallic conduit without couplings, joints, or connections is allowed to run completely through the shaded area at 6 feet or higher above the gas meter regulator vent. The continuous conduit may curve upward and out of the top of the shaded area. Service conduit from the electric meter panel to the weatherhead location must not run horizontally along the top of the roof.

Notes continued on the next page

. . . (continued)

otes in reference to Figure - (continued).

- . Electric wiring for new photo voltaic or electric meter upgrades may pass through the clearance area shown in Figure - if the wires are in a metallic, continuous sleeve (conduit) with no joints, couplings, or fittings. The sleeve must extend a minimum of feet on either side of the meter set and must be a minimum of 6 feet above the regulator opening.
- . See [Section 2, "Gas Service," Figure 2-19, "Electric and Gas Meter Set Separation Dimensions and Clearances."](#) ote and ote 6, on Page 2- , for information about gas facilities.
- 6. Applicants must not install water spigots, water lines, cleanout drain lines, gutter systems, or other sources of above-ground or below-ground water to within 6 inches as measured in a straight, horizontal line of any gas facilities or underground electric meter panels and facilities.
- . For overhead service-meter panels and equipment, applicants must ensure that the clearance from above-ground downspouts and other nonpressurized (i.e., gravity fed) wet facility sources is a minimum of 12 inches radially from the meter panel.
- 8. Above-ground water lines, sprinkler systems, and other objects mounted on the wall or above grade are not allowed in any part of the working space in front of the electric meter panel.

### orking Space

orking space is defined as the whole area in front of the meter panel, the meter enclosure, the CT section, the service-conductor pulling or termination enclosure, or associated equipment. A working space permits access to the equipment and provides a safe working environment for personnel.

A working space must be located entirely on the applicant's property or only located in the public right-of-way or municipality or state-owned land. Ask your local project coordinator to contact the PG&E electric meter department to review and approve of any exceptions to the Company's requirements for metering work spaces and locations.

The working space must be clear, level, and unobstructed at all times. See the minimum required dimensions in Table -2, "orking Space Dimensional equirements," on Page -18.

In flood plains or other areas where elevated platforms are required in front of the meter, install permanent safety rails. The platform must be approved by the local metering department and meet specific PG&E requirements.

all-Mounted E uipment: Includes, but is not limited to, service and metering equipment mounted on building or structure walls, panelboard structures, poles, posts, and communication pedestals.

For meter panels and service equipment, the working space is 30 wide x 36 deep x 75 inches tall. See Figure - , "Semi-Flush Meter Installation," and Figure - , "Enclosed Meter Installation," both on Page -19.

Improved Surface: Applicants must ensure that the entire working space for multi-residential and nonresidential locations with wall-mounted meter panels or pad-mounted, single-metered pedestals up to 200 amps has an improved surface that is constructed from the same material. The improved surface material can be concrete, stone pavers, asphalt, or compacted gravel. The selected improved surface must extend a maximum of 1 inch above grade. All improved surfaces must be completely level. ative soil (dirt) is not an improved surface for the working spaces in these locations.



. . . (continued)

The following requirements apply for each improved surface:

- Concrete: Minimum 4,000 pounds per square inch (psi), precast pad allowed. Poured concrete must be a minimum of 4 inches thick and have wire mesh or rebar.
- Stone pavers: Minimum 2 inches thick, spaced not more than 1/2 -inch apart.
- Asphalt: 2 inches thick on top of 2 inches of angular gravel.
- Gravel: Aggregate sized at 1/2 inch to 3/4 inch diameter without sharp edges, compacted to 95 density, surrounded either by a galvanized metal or pressure-treated wood border on each side and connected together.

Clear-Standing (Pad-Mounted): Includes, but not limited to, switchboards, switchgear, pedestals metering enclosures, and service termination equipment rated over 225 amps. Use concrete to construct the working space surface area. The working space width is the same dimensional width as the equipment section.

Concrete floors, housekeeping pads, and elevated platforms must extend out in front of the whole area to the minimum working space depth. Measure the depth from the outside of the equipment's outer door. See Figure 1-6, "Preferred Location of Conduits for Indoor and Outdoor Meter Panels and Switchboards," on Page 1-20 for additional requirements.

Table 1-2 Working Space Dimensional Requirements 2,

Voltage (volts)	Meter/Service Equipment Type	Dimensions (Inches)			Figure(s)
		Width <sup>1</sup>	Depth	Height	
-	Clearance				
	Clearance inside Cabinet	See Note			
	Clearance Pedestals				
	Clearance Pedestal Section Extension	See Note		See Note	
-	Clearance	See Note		See Note	

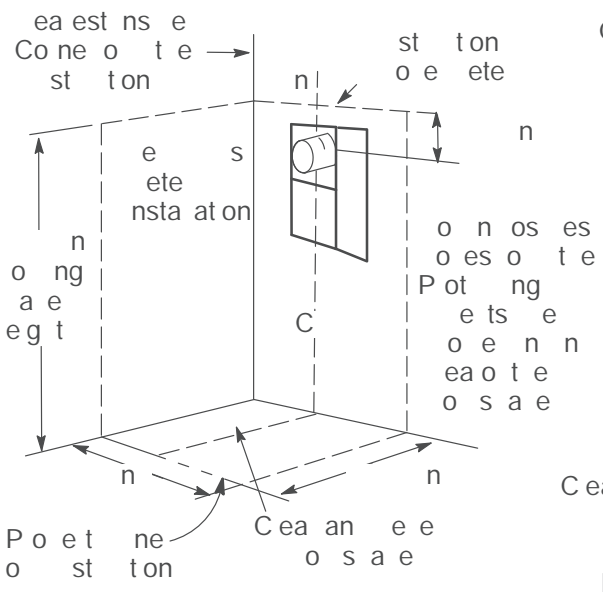
1. The minimum clearances shall be as stated in this table and shall be maintained throughout the life of the installation.

2. For outdoor installations, the clearances shall be increased by 18 inches for all dimensions unless otherwise specified.

3. For indoor installations, the clearances shall be as stated in this table.

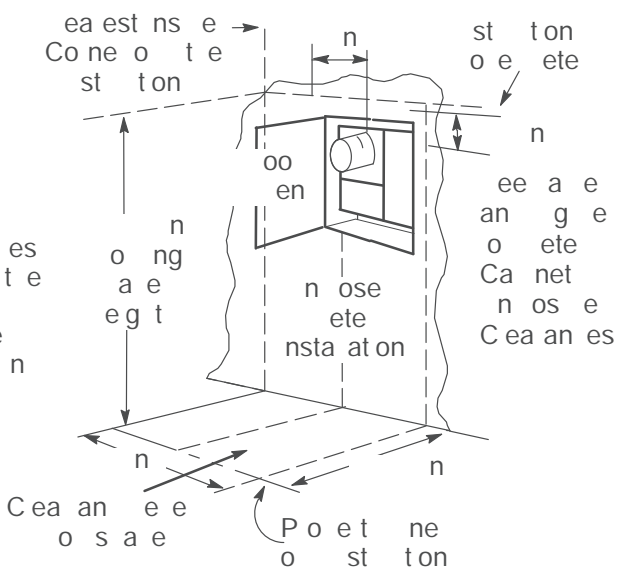
4. For outdoor installations, the clearances shall be increased by 18 inches for all dimensions unless otherwise specified.

. . . (continued)



Installation of the meter should be in accordance with the manufacturer's instructions. The meter should be installed in a location that is accessible for reading and maintenance. The meter should be installed in a location that is protected from physical damage and weather conditions.

Figure - Semi-Flush Meter Installation



Note: The meter should be installed in a location that is accessible for reading and maintenance. The meter should be installed in a location that is protected from physical damage and weather conditions.

Figure - Enclosed Meter Installation

*cited in Cal. Rest. Ass'n v. City of Berkeley  
No. 21-16278am archived December 27, 2023*

Section , Electric Metering: General

. . . (continued)

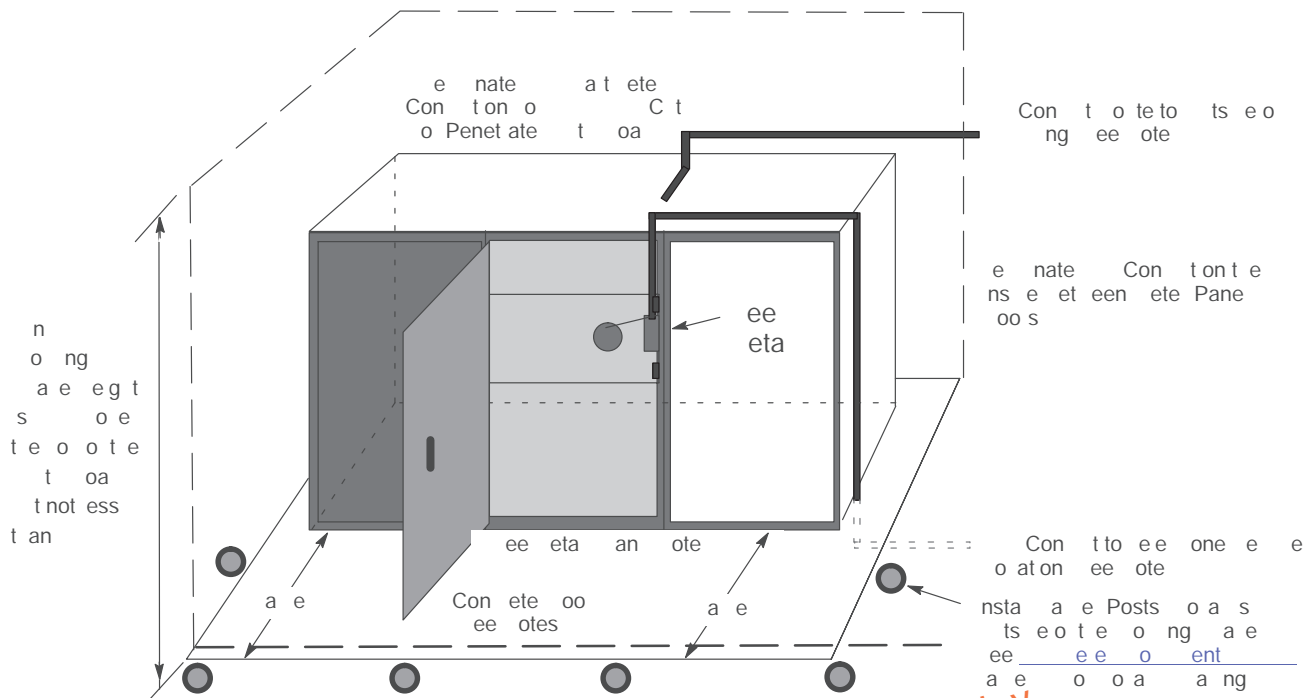
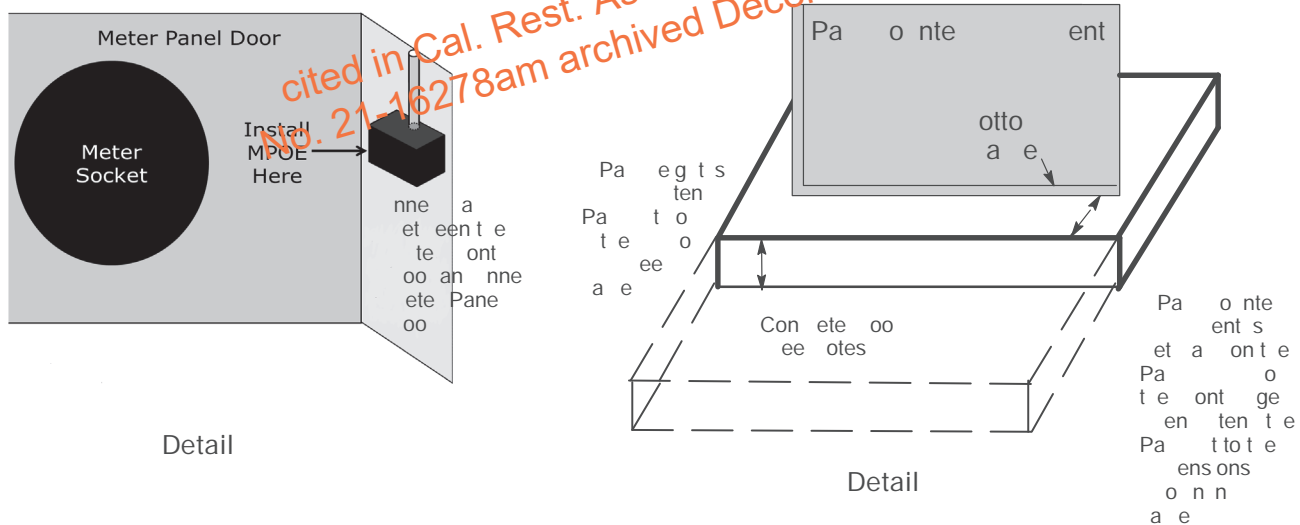


Figure - Preferred location of Conduits for Indoor and Outdoor Meter Panels and Switchboards



Notes in reference to Figure -6.

1. A level, concrete structure (e.g., floor, pad) must extend out the minimum-required distance in front of all sections to which PG&E requires access. This structure is used for floor-standing equipment (e.g., switchboard, pedestals greater than 200 amps, termination enclosure).
2. A 1/2-inch phone-line conduit may be required for all indoor and outdoor meter panels rated 100 kV or greater. See Item E. and Item F. in Subsection .2. ., "Applicant Responsibilities," on Page - . A 2-inch SmartMeter conduit is required only for indoor, wall-mounted or pad-mounted meter-panel enclosures of any size.

Notes continued on the next page

. . . (continued)

otes in reference to Figure -6 (continued).

- . The switchboard's bottom horizontal support frame must not protrude more than inches above the floor or pad. This is in front of all PG&E sections (see Detail B).
- . The pad-mounted equipment must be set back less than 2 inches from the front edge of a raised pad. And the concrete pad must be less than 2 inches above the ground or floor. This is true for all PG&E sections. Otherwise extend the pad outward.
- . For the finished surface type, see Subsection . . . , "orking Space," on Page -1 .

#### arricades

In areas where either the meters and service termination equipment or the working spaces are exposed to vehicles or hazardous conditions, a permanent barricade outside of the working space is required. PG&E determines when this type of protection is required.

Physical protection from vehicular traffic is provided based on the level of vehicular exposure. Applicants must protect all electric metering and service termination equipment located in the following areas:

A. ithin feet of the following areas:

- Single-family residential driveways or parking areas (including garage areas)
- Thoroughfares
- Multifamily or nonresidential (i.e., commercial or industrial) driveways or parking areas
- Commercial refuse container locations
- oading docks and freight-handling areas
- Paved areas without curbs

B. ithin an area that has, in PG&E's judgement, an unusually high risk of vehicular damage, the applicant must install a system of barrier posts (bollards) that meet PG&E's specifications.

A suitable barricade for vehicular traffic is concrete-filled steel pipes, either inches or inches in diameter, securely set in an adequate concrete footing for support. Permanently installed posts are re uired. Do not use removable barrier posts or bolt-down-type barrier posts for metering and service-termination equipment.

See Figure - , "Meter Panel Clearance and Protection From esidential ehicle Driveway or Parking Space," on Page -22, and Figure -8, " onresidential or Multifamily Metering and Service Equipment Clearance and Protection From onresidential or Multifamily ehicle Areas," on Page -2 .

For information on ordering and installing bollards, see [umbered Document 0 1122, "Clearances and ocation equirements for Enclosures, Pads, and nderground Equipment,"](#) Page 2 through Page 2 . This document is included in [Appendix C](#).

. . . (continued)

Contact your local PG&E inspector and project coordinator to determine if a barricade is required.

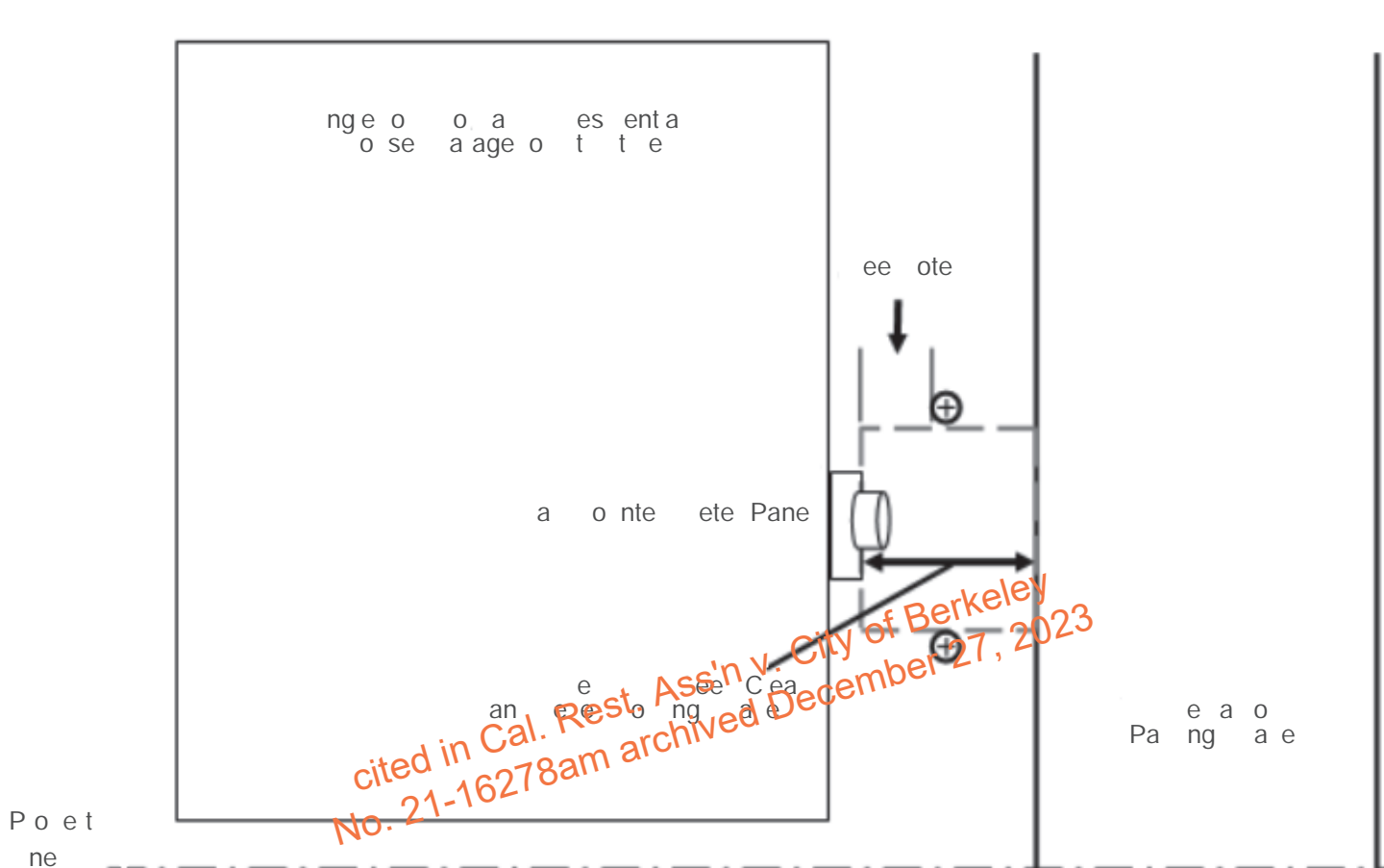


Figure -7

Meter Panel Clearance and Protection from Residential Driveways or Parking Spaces

Notes in reference to Figure -7 :

1. If a permanent barrier or obstruction (e.g., fireplace, wall, curb) exists less than 12 feet to the side of the meter panel and protrudes outward a minimum of 12 inches from the building farther than the meter panel, then the meter panel may be considered sufficiently protected. A PG&E inspector or meter technician will make this determination. Obstructions are not allowed in the working space.
  2. For single-lane driveways or parking spaces a minimum of 12 feet wide with meters installed at a height of 66 inches to 78 inches as measured from the ground to the centerline of the meter, or with a meter panel installed in a permanent cabinet with a meter height of 68 inches to 78 inches, the meter panel may be sufficiently protected. A PG&E inspector or metering technician make this determination. For cabinet specifications see Figure -2, "Meter Cabinet Enclosure Clearances," and Table -1, "Meter Cabinet Enclosure Clearance Dimensions," both on Page -1 .
- . If the descriptions for protected meters provided in Note 1 or Note 2 do not apply, then install permanent (fixed) bollards (barrier posts) 20" to 36" apart and outside of the 30-inch-wide meter(s) working space(s). The client must ensure that the bollards are installed a minimum of 6 inches to a maximum of 18 inches from the front of the meter panel. Refer to [umbered Document 0 1122](#) for the bollard spacing and installation requirements. Note that 2-inch bollards are allowed only for single-family or two-family residential applications. Refer to [umbered Document -9](#) , "Meter Guard Design and Installation Arrangement," (located in [Appendix C](#)) for the 2" bollard requirements. Bollard material specifications and material codes are listed in Table - , "Bollard Post Materials," on Page -2 .

. . . (continued)

Table - ollard Post Materials

Description	Length	Code	Document
... (mirrored text from previous page)			---
... (mirrored text from previous page)			---
... (mirrored text from previous page)			---
... (mirrored text from previous page)			---

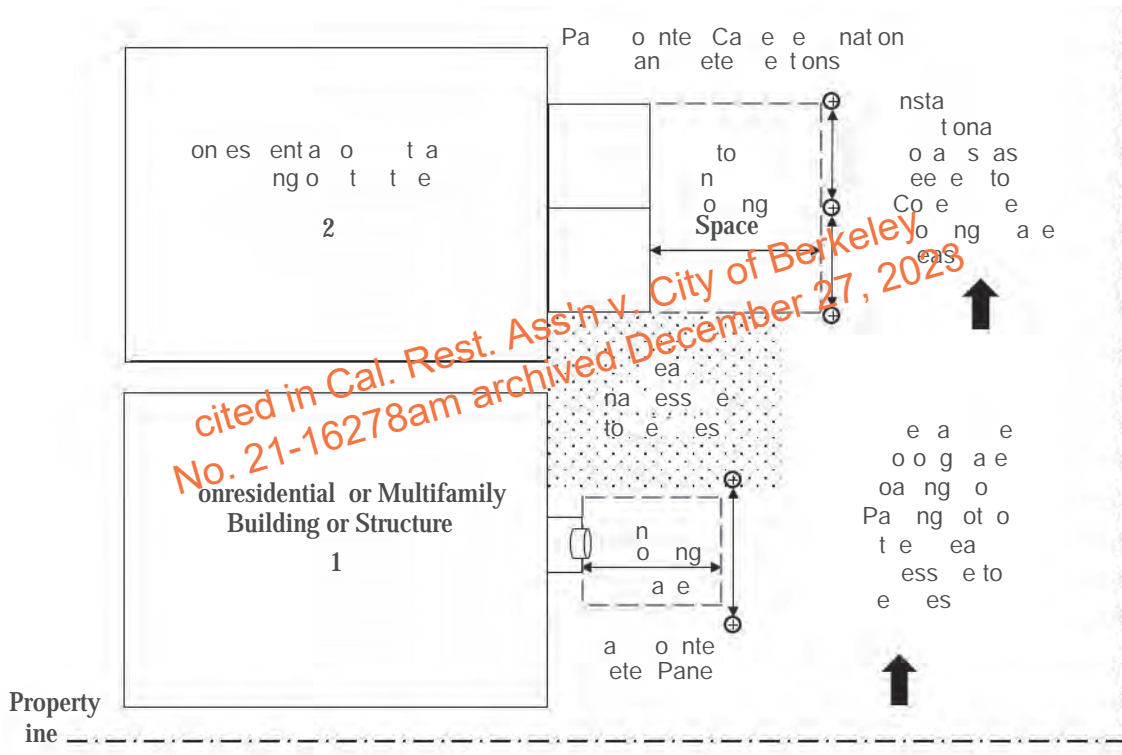


Figure -  
Nonresidential or Multifamily Metering and Service Equipment  
Clearance and Protection from Vehicle Rears

Notes in reference to Figure -8:

1. Install permanent (fixed) bollards outside the working space, as required. See the exceptions below in Note 2 and Note .
2. If a minimum 6-inch high, permanent curb or equivalent barrier is present and outside the working space, bollards may not be required for low-traffic and light-duty vehicle areas. A PG&E inspector or metering personnel make this determination.
- . If a minimum 6-inch high, permanent, vehicle parking stop or other equivalent barrier is at least 2 inches away from the front of the working space, then bollards may not be required in light-duty vehicle areas only. A PG&E inspector or metering personnel make this determination.
- . See [umbered Document 0 1122](#) for bollard spacing, material specifications, and installation requirements.

## Meter Protection

Applicants must ensure that meters and metering equipment are enclosed in a protective cabinet in the following situations. Meter heights less than 6 inches are not allowed.

- A. For all installations, when the meter is less than 8 inches high, as measured from the horizontal centerline of the meter to the standing surface. Meter heights less than 6 inches are not allowed.
- B. When the meter is mounted on, or recessed in, any wall at a school or similar establishment and public safety is an issue.
- C. When environmental problems are anticipated.
- D. When corrosion problems are anticipated or present.
- E. When anticipating vandalism.

Any protective structure surrounding meters and metering equipment must be pre-approved by the local meter shop and provide safe working conditions as determined by PG&E. Approval from the local authority having jurisdiction also may be required.

When a fence or surrounding structure is approved to be built around service termination and metering equipment (e.g., switchboard, switchgear), the doors or gates leading into the structure must open outward away from the equipment being installed and are preferred to be located on the front of the structure.

If the door(s) or gate(s) into the structure are on the sides or the back of the service termination and metering equipment, the working space depth in front of the equipment is required to be increased to twice (e.g., 8 feet times 2 = 16 feet) the distance. If there are doors on the back of the switchboard or switchgear with PG&E equipment inside, or if there are multiple switchboards inside the enclosed structure, the same requirements apply.

## Meter Identification and Seals

### 1 Properly Identifying and Marking Meters

Applicants must ensure that each individual meter position, its service disconnecting means, and the unit or dwelling being served is marked clearly and permanently. PG&E will not install meters unless the permanent address, the location, or, when applicable, the area being served is marked at each meter location. Three of the following examples describe acceptable permanent markings. One example describes unacceptable markings.

- A. Preferred: An identification plate attached by screws, rivets, or weatherproof adhesive.
- B. Non-preferred but acceptable: Paint that cannot be removed using common solvents. Apply the paint using a stencil.

. 1. (continued)

- C. Non-preferred but acceptable indoors: Manufactured decals that are not installed outdoors and will not peel or fade.
- D. Unacceptable: Tape-type and label-maker stick-on labels hand-written lettering (sharpie, paint stick, etc.).
- E. Temporary: Temporary meter panels rated up to 200 amps that will be installed less than one year and will not be used as a temporary-to-permanent installation may use hand-written lettering that is legible to PG&E as well as any marking methods described in Item A. through Item C (above).

NOTE: For outdoor meters, the marking material must have an ultra violet ( ) protection rating.

The identification must be legible. It must include a specific apartment number, a street number, use, or location. Ensure that the information is verified. A store name or other generic description may be included, but does not constitute acceptable identification when used alone.

Where individual meters serve a remote location, or where meters are grouped at a common location (both residential and nonresidential), applicants must ensure that they mark the sites or buildings and identify meters properly.

For meters serving agricultural pumps or other large equipment, mark the ampacity rating of the main service disconnecting means (i.e., breakers, fuses) along with the type of equipment and the nameplate rating or multiple individual disconnects with a main disconnect, mark the aggregate rating or all of the disconnects installed.

PG&E will not install meters without a permanent address or location mark at each meter location.

When it is appropriate, applicants should include the area being served by the meter when permanently marking the site.

PG&E may make an exception to the rules for permanent marking when the Company is requested to set a meter for a single-family home that is under construction. In this case, PG&E will set the meter if the home's address is noted clearly and legibly either on the street side of the dwelling or on the lot in front of the dwelling. PG&E understands that during construction, the "permanent" address sometimes is not available when the dwelling is ready for the meter to be set.

Customers who install distributed generation (e.g., solar, wind, battery storage) that is connected to the electric meter panel are required to install permanent signage affixed to the panel indicating an alternative source of generation is interconnected. Signage and maps also are required at the meter panel for the alternating current (ac) disconnect switch location when it is more than 10 feet away and out of the line of sight from the meter panel.



## 2 Sealing Meters and Metering Equipment

**PG&E seals all meters and enclosures for utility meters, metering equipment, and service-entrance equipment using PG&E's seals.**

Applicants cannot locate or install equipment within meter sections, meter panels, switchboard sections, or equipment enclosures without existing PG&E seals unless they receive authorization from the PG&E electric meter group.

**EXCEPTION: Equipment that provides access for replacing over-current protection fuses is exempted.**

**Only an authorized PG&E representative can break the PG&E seal.**

**Certified meter service providers (MSPs) also will seal all meters and enclosures for meters, metering equipment, and test-bypass switches owned by their respective companies with their companies' seals, as described in the [D SMMD in California](#) (March 1999) document.**

### Locking Provisions

All transformer-rated and all three-phase installations must have provisions for sealing or locking all of the main service switches or breakers in a permanent (off) position. When installing service equipment of any phase or ampacity that contains multiple service (disconnect) switches, the applicant must ensure that provisions for locking each individual service (disconnect) switch are provided.

If the main breaker or service disconnects are installed in an enclosure, the door(s) for the enclosure also must have locking provisions that accept a PG&E lock or other locking mechanism and can accommodate more than one lock. Do not use a keyed lock handle (e.g., T-handle) to secure enclosures.

The applicant must ensure that the locking mechanism is a permanent installation and that the clip, with a hole for the lock shaft, is made of a rigid metal. The breaker or switch covers can be nonmetallic. Finally, the applicant must ensure that these provisions are sealable and lockable with a padlock having a 1/16-inch lock shaft.

### Meter Types and Connections

The following requirements refer specifically to meter types and connections. Applicants must follow the guidelines listed below.

- A. When installing a new service, ensure that the panel enclosures rated at 12 amps are Class 100 ampere services. Services and enclosures rated at 22 amps are Class 200 ampere services.
- B. Ensure that transformer-rated meters have a current rating of less than 100 amps (e.g., C 5, C 10, or C 20).
- C. Do not use panel-based (i.e., bolt-in) meters when designing new installations. Services that need 100 amps (continuous) require current-transformer facilities.

.6. (continued)

D. Ensure that sockets meet the requirements of Standard - 1, “Standard for Meter Sockets.”

E. Locate potential taps, including the neutral connection, behind a sealed panel.

F. Ensure that the meter manufacturer designs and fabricates transformer-rated meter sockets that are installed on hinged panels for back connection.

Applicants should use Table - , “Meter Socket Requirements (Number of Poles),” on Page -2 , to find specific meter-socket requirements and to ensure they provide the proper equipment.

Table - Meter Socket Requirements (Number of Poles)

Service			0–22 amperes	22 – 20 amperes <sup>1</sup>	00 amperes and above
Voltage	Phase	No. of Poles	Self-Contained	Self-Contained	Transformer Rated
					0
					0
					0

<sup>1</sup> A socket-based, Class 20-ampere (continuous) meter will be installed on a Class 00 meter panel, rated at 80 continuous (i.e., 20 amps). Do not use Class 00, bolt-in meters on new installations. Service rated at 00 amps continuous requires current transformers to be installed.

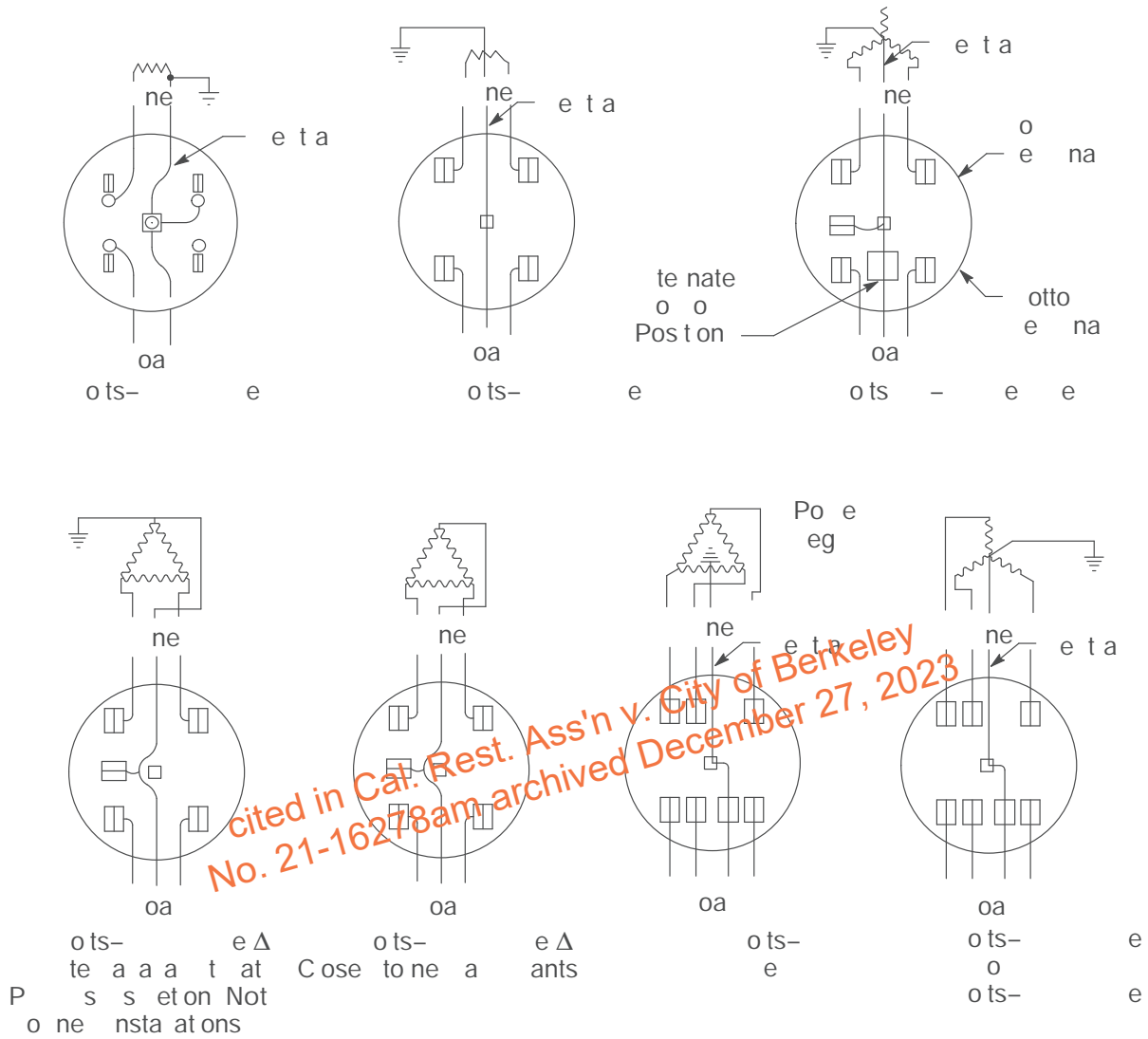
<sup>2</sup> Only use a 1-jaw meter socket for a Class 20-ampere meter for single-phase residential applications. In locations where PG&E maintains a 120/208-volt secondary system, 3-wire, single-phase service, typically the service is limited to what can be supplied by a main switch or service entrance rating of 22 amps. Single-phase loads that exceed the capacity of a 22 -ampere main switch or service-entrance rating usually are supplied with a 120/208 -volt, three-phase, 3-wire service.

The 1 -jaw socket is acceptable, but not required.

limited availability, at PG&E’s discretion. Not for new installations.

Figure -9, “Connection Diagrams for Self-Contained Meter Sockets,” and Figure -10, “Connection Diagrams for Transformer- rated Meter Sockets,” on Page -28, show the required connections for self-contained and transformer-rated meters.

.6. (continued)



Front i e s Sho n

Figure -

Connection Diagrams for Self-Contained Meter Sockets

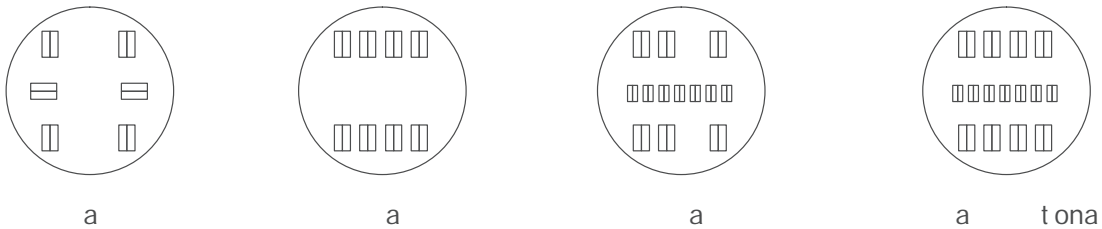


Figure -10

Connection Diagrams for Transformer-Rated Meter Sockets

NOTE: PG&E is responsible for wiring transformer-rated meter sockets.

- 1 Using a Meter Socket Adapter for Overhead-to-Underground Conversion

Applicants may use approved meter socket adapters to convert existing services. Do not use them to establish new service. For more information, see PG&E's [Numbered Document 0610 2, "Residential and Small Commercial Overhead to Underground Electric Service Conversion."](#)

Consult a PG&E project coordinator to determine which conversion method to use. The applicant must ensure that the meter socket adapter's grounding strap is connected to the grounded wire within the meter panel.

- 2 Installing Non-Allowed and Unauthorized Customer Equipment

Applicants must not install any type of customer or third-party-owned meter-adapter, surge suppressor or protection device (e.g., TSS), meter socket adapter, power usage or recording device, security or monitoring equipment, or similar interface device in, on, or between the electric revenue meter and meter sockets or inside any PG&E sealed section, including the instrument transformer (i.e., CT, PT) or service termination sections. These types of installations are not allowed and compromises the applicant's electric service. If safe to do so, PG&E personnel will remove any customer-owned devices and leave them on the applicant's premises if they are discovered.

Only PG&E-approved meter socket adapters used for overhead-to-underground conversions and PG&E's green meter adapter (GMA) used with specific types of residential solar (e.g., photo-voltaic) generation systems are exempt.

#### Fire-Pump Connections

PG&E allows the following types of service connections to new and existing switchboards and fire-pump meter panels. The requirements are described below.

- A. All fire-pump service connections must be approved by the local city, county, or state inspecting Authority having jurisdiction (AHJ). Site plans and equipment drawings must be submitted to PG&E for approval.
- B. The service disconnect, meter panel, switchboard, or switchgear for the fire pump must be located in the same electrical room as the main service meter panel, switchboard, or switchgear, as well as the utility termination section. They cannot be located in another room or building. When installed outdoors, the equipment must be located next to each other.
- C. For switchboards rated up to 600 volts (i.e., secondary), the following types of connections are allowed.
  1. Preferred connection for new switchboards: A fire-pump service connected in a dedicated tap section installed in the main switchboard. See Option 1 in Figure -11, "Fire-Pump Equipment Location and Service Connection Options," on Page - 1.

.6. . (continued)

If allowed, the local Authority could require the tap section to be located away from the main breaker on the opposite side of the termination section.

2. Alternative connection for new or existing switchboards: A fire-pump service connected to the load side (i.e., after the main breaker) of the main switchboard. See Option 2 in Figure -11 on Page - 1.
- D. For switchgear (i.e., primary) rated between 601 2 ,000 volts, applicants can use the following types of connections.
1. A fire-pump service connected in a dedicated tap section of the switchgear.
  2. A fire-pump service connected to the load side (i.e., after the main breaker) of the main switchgear.
- E. For main switchboard or switchgear service termination equipment rated between 0 2 ,000 volts, applicants can use the following type of connection.
1. A separate and dedicated utility service that is connected directly to the fire-pump meter panel, switchboard, or switchgear. Usually, this is referred to as a second PG&E service. See Option in Figure -11 on Page - 1.
- F. Do not place a fire-pump service tap or connections in the utility termination, instrument transformer, or metering sections.
- G. Ensure that the wiring configurations for fire-pumps (either -wire or -wire) are the same as the wiring configurations for the main switch.
- . Ensure that required access panels and required signage for meter panels and switchboards serving fire pumps are installed.
- I. Ensure the ampacity rating of the fire pump switchboard or meter panel does not exceed the ampacity rating for main service termination equipment (e.g., main switchboard, meter panel).

6. . (continued)

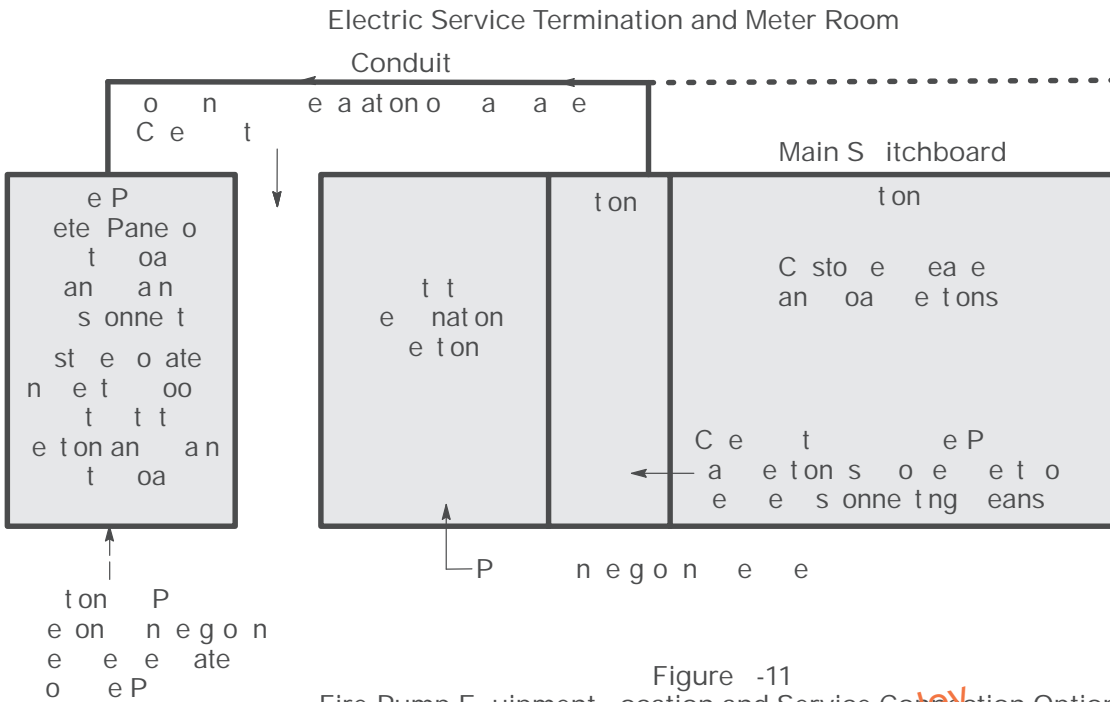


Figure -11  
Fire-Pump E uipment ocation and Service Connection Options

7 Main Service Disconnects and Switching Sequences

7.1 Main Service Disconnects

For each installed meter, the applicant, in compliance with applicable codes, must furnish and install a fusible switch, circuit breaker, or other approved disconnecting means for controlling all of (and only) the energy registered by that meter. When the governing code or ordinance permits, the disconnect means may consist of a group of fusible or circuit-breaker disconnects. PG&E requires access to these disconnects.

For all metering equipment, applicants must place the main service disconnect switch adjacent to the meter(s), not more than 10 feet away and within line of sight. The main service disconnect switch may be located inside an approved meter room or outside of the building being served, while adjacent to the metering equipment.

PG&E prefers applicants to have provisions for individual disconnects when they use switchboards with multimeter installations.

NOTE: See [Section 1, "General," Subsection 1.1 .. "Determining the Service Rating," Paragraph B., "Enclosure Nameplate Labeling and Rating."](#) when more than one disconnecting means is installed.

7.2 Main Service Disconnect Switch Rated for Amperes Interrupting Capacity (IC)

State and local codes require the service equipment's main disconnect switch and fuse, or the circuit breaker, to be rated at the available short-circuit current value.

. .2. (continued)

When possible, PG&E designs its facilities so that the short-circuit duty at the service termination will not exceed 10,000-amps symmetrical for new, single-family, residential applicants that are supplied by an individual service drop or lateral that is rated at 22 amps or less. This service includes mobile homes and duplexes.

For short-length service drops or laterals rated at 22 amps or less that are constructed from the PG&E distribution system to the service termination equipment, it is not practical for PG&E to design its facilities to limit the short-circuit duty to 10,000 amps. For short-service installations and for all service termination equipment rated greater than 22 amps, PG&E provides, on request by the applicant, the maximum-available short-circuit current based on the service equipment's capacity. If the applicant increases the service equipment's capacity, the maximum-available short-circuit current may be higher.

7 Arc Flash Assessment

PG&E's electric system is dynamic and continually being reconfigured due to system needs and general maintenance. Therefore, due to its many variables, a range of impedance's should be considered in an arc flash assessment. To request an arc flash assessment, contact your local project coordinator.

7 Electronic Trip Circuit Breakers

Electronic circuit breakers using a trip unit are programmable devices that measure the current flowing through the circuit breaker and initiate a trip signal, when appropriate. An electronic trip unit has multiple dials that can be adjusted to various settings.

The I setting is the continuous current value and must not exceed the ampacity rating of the enclosure. It is similar to the capacity or ampacity rating on thermal or thermal magnetic circuit breakers. The I settings must be indicated on the trip unit. The I settings typically are lettered and identified on a chart with the corresponding ampacity values. Electronic trip units are available with multiple ratings for each standard frame size.

The circuit breaker frame is the housing that contains the current-carrying and current-sensing components, along with the tripping and operating mechanism. The frame size (e.g., 800, 1,200, 1,600 amps) is the largest ampere rating available in a group of circuit breakers of similar physical configuration. Other types of breakers may have different frame sizes.

. . . (continued)

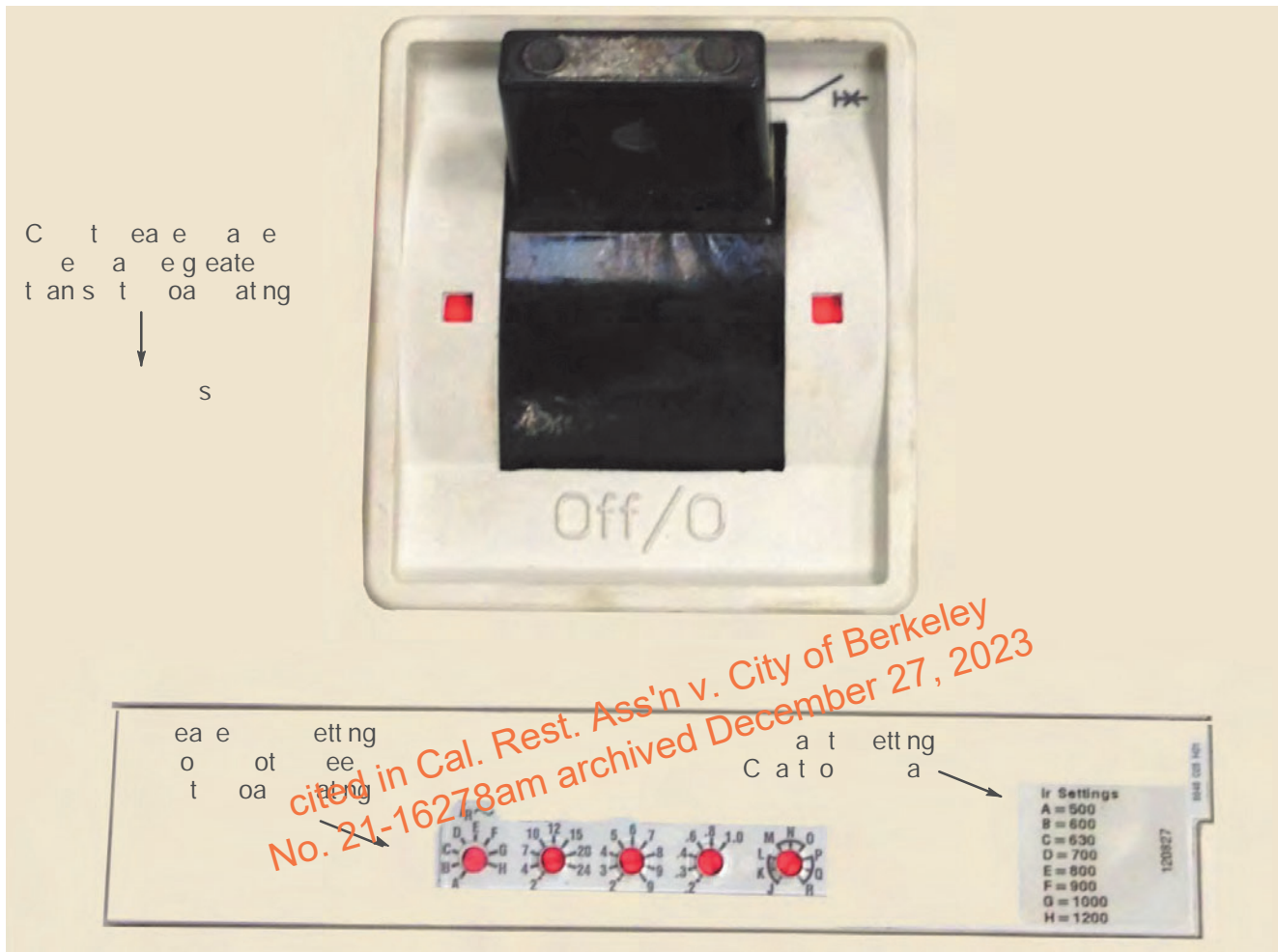


Figure -12  
 Circuit breakers with Electronic Trip unit

Note in reference to Figure -12.

1. Match the letter on the dial to which the arrow head is pointing with the letter on the setting chart to determine the ampacity setting for the breaker.

7 Meter and Main Service Switch Sequence

PG&E places its meters and metering equipment ahead of (i.e., on the supply side of) the applicant's main service disconnecting means. Figure -1 , "Single Meter with Main Service Switch," Figure -1 , "Single Meter with Multiple Service Switches," and Figure -1 , "Multimeter Disconnect without Main Switch," below, all provide examples of this type of installation. Figure -1 , "Multiple Remote Switchboard or Meter Panel locations," on Page - , also provides an example of meter and main service switch sequences for large projects with multiple meter rooms or buildings.



. . . (continued)

PG&E permits exceptions to this sequence only in circumstances where applying the electrical code requirements result in the applicant's main service disconnect means being installed ahead of PG&E's metering and metering equipment. Figure -16, "Multimeter Installation with Main Disconnect Switch," below, provides an example of this type of installation. In these instances, an individual disconnect switch also must be installed on the load side of each meter.

The local jurisdiction having authority for enforcing the electrical code requirements determines most of the requirements that applicants must follow when installing their means to disconnect. PG&E requires a main service disconnect for multimeter installations with more than six meters or individual service disconnects.

In large meter rooms where additional metered switchboards may be electrically connected after the main switchboard, or where wall-mounted meter stacks are electrically connected to a tap section of a switchboard, a map and signage indicating where the main service breaker is located are required on each connected switchboard or meter stack.

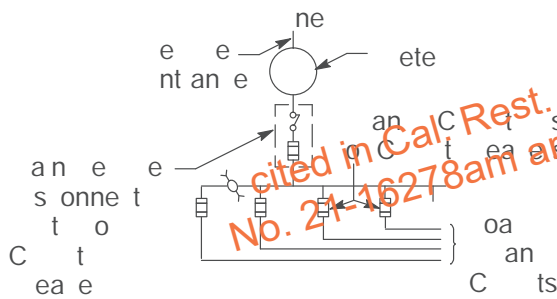


Figure -1  
Single Meter with Main  
Service Switch

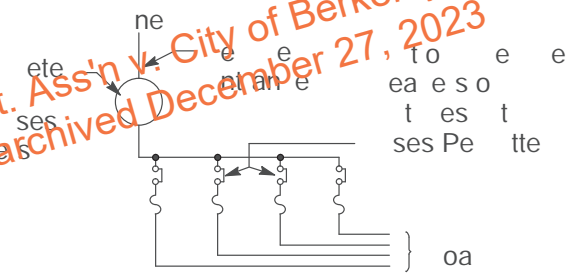


Figure -1  
Single Meter with Multiple  
Service Switches

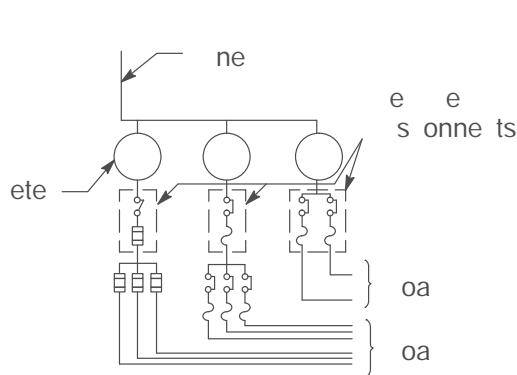


Figure -1  
Multimeter Installation without  
Main Disconnect Switch

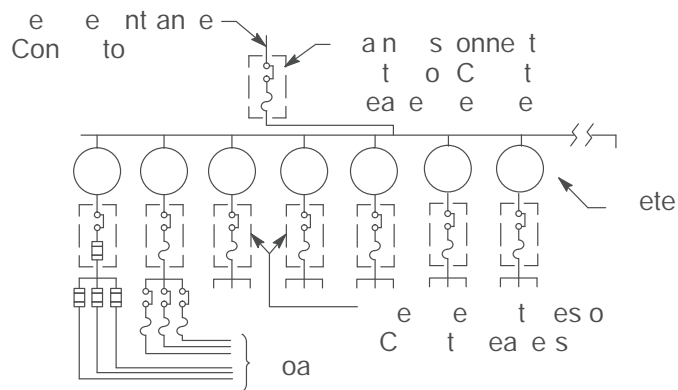


Figure -1  
Multimeter Installation with  
Main Disconnect Switch

*cited in Cal Rest. Ass'n v. City of Berkeley  
No. 21-16278am archived December 27, 2023*

. . . (continued)

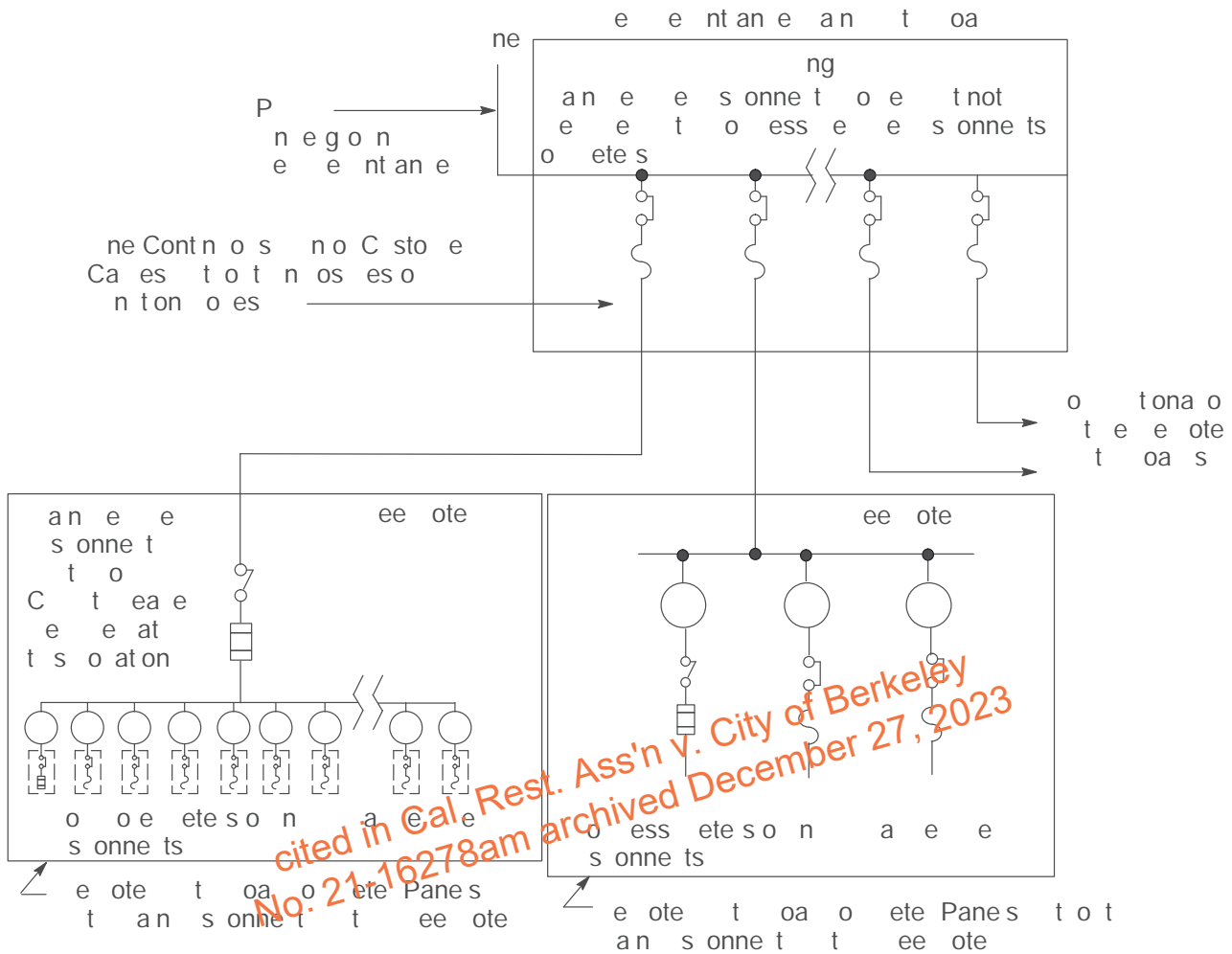


Figure -17  
Multiple Remote Switchboard or Meter-Panel Locations

notes in reference to Figure -1 .

1. When a switchboard or meter panel is located in a different room, floor, or building from the main switchboard, it is considered remote.
2. Customer services installed from the main switchboard to remote switchboards or meter panels must be one continuous run of cables without any entering enclosures or junction boxes along the path.

### Grounding

Applicants must bond and ground their electric services and metering equipment as required by applicable electrical codes, local ordinances, and PG&E requirements.

A. Applicants must not use PG&E’s gas facilities as part of the electrical grounding system.

1. Do not install electrical devices or equipment, wires, cables, bonding or grounding wires, clamps, or ground rods around the gas meter set as shown in Figure 2-19, “Electric and Gas Meter Set Separation Dimensions and Clearance,” on Page 2- , and Figure 2-2 , “Dimensions for Typical, Residential, Multimeter Installations,” on Page 2- 0.

## .8. (continued)

2. Do not use PG&E's gas service piping, gas risers, or meter facilities for electric bonding or grounding that allows the gas meter, piping, or other gas facilities to become current-carrying conductors.
  - . Do not allow gas pipe to be electrically bonded within meter enclosures, cabinets, or meter rooms.
- B. PG&E supplies single-phase, 120/208-volt and 120/208-volt services and three-phase, 3-wire wye and delta services with a grounded service neutral conductor. When PG&E permits a three-phase, 3-wire, 208-volt service, one phase conductor must be grounded.
- C. Applicants must locate the terminations (e.g., ground terminal) or their grounding electrode conductors outside of any section that PG&E seals. Applicants must ensure that their terminations are designed to permit their grounding systems to be isolated, when necessary, from PG&E-supplied services. See "Notes in reference to Figure -18 and Figure -19," on Page - , specifically note , "Equipment Bonding," which requires a continuous bond wire when grounding outside of the PG&E sealed section.
- D. Applicants must not locate their grounding electrodes, grounding electrode conductors, or grounding ring conductors inside or near any PG&E electrical distribution equipment, enclosures, or vaults.
- E. As mandated in the applicable sections of the electrical code, applicants may be required to physically protect their grounding electrode conductor against mechanical damage. PG&E prefers, but does not require, the grounding electrode conductor wire to be protected against physical damage by rigid steel conduit or armored cladding. Metal conduit must be bonded to an effective, grounded, fault-current path as described in the electrical code requirements.
- F. Applicants must ensure that a grounded neutral connection, which is required for safety and metering purposes, exists in the PG&E-sealed section and is terminated in the same enclosure as the grounding electrode conductor.
- G. When installing ground rods, applicants must only use approved ground rods and clamps as described in [umbered Document 01 109, "Corrosion Resistant Ground Rods and Ground Rod Clamps,"](#) located in [Appendix C](#). For homes and buildings, an alternative grounding system using rebar is an acceptable substitute to the ground-rod method.
 

When ground rods are installed for concrete pads, refer to [umbered Document 0 292, "Concrete Pad for Three-Phase, Loop-Style, Pad-Mounted Transformers."](#) When ground rods are installed for equipment pads other than transformers (e.g., switchboards), install them according to their application. Finally, when installing ground rods in box pads, use [umbered Document 06 09, "Box-Pad for Pad-Mounted Transformers."](#) for installation information.

  - . To ensure proper access to PG&E facilities during installation and maintenance, do not attach the bonding and grounding attachments for communication equipment on or near any PG&E sealed sections of the meter panel that would restrict access to the panel doors and meter.

.8. (continued)

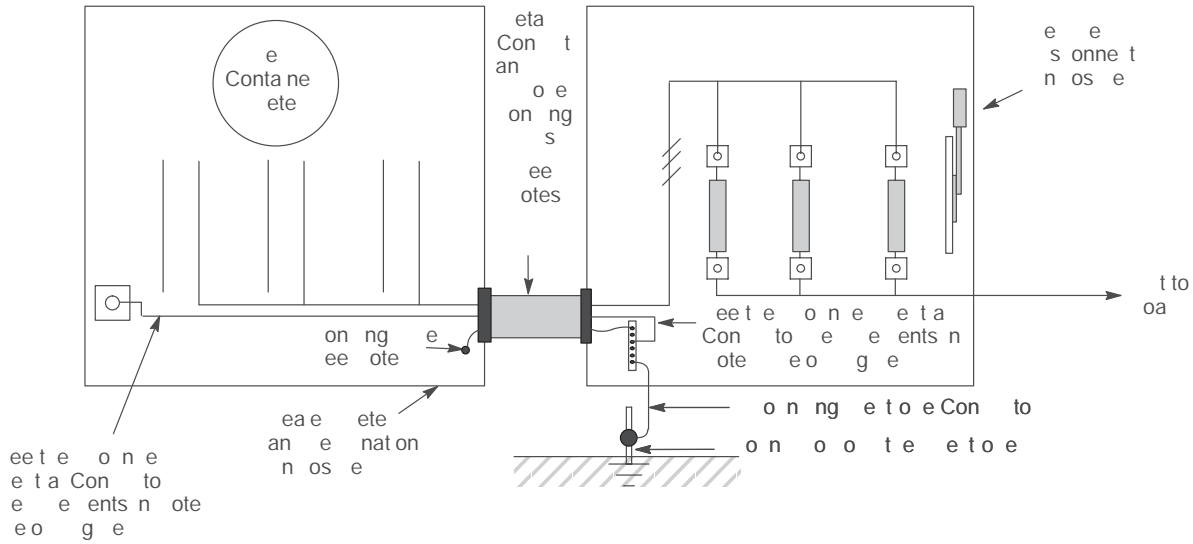


Figure -1  
Grounding Outside of the Sealed Section—Self-Contained Meter

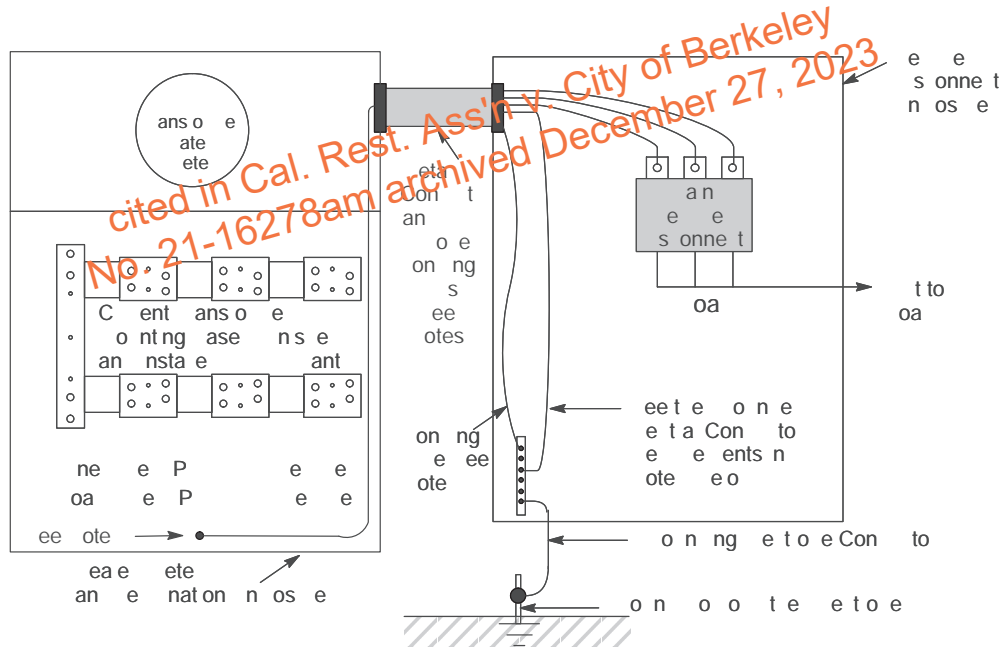


Figure -1  
Grounding Outside of the Sealed Section Transformer Rated Meter

Notes in reference to Figure -18 and Figure -19 are required for the safety of workers and the proper operation of PG&E facilities.

1. Neutral Conductor: PG&E requires that the neutral conductor be grounded. Ground the neutral conductor by using the preferred methods described in Note 2 and Note 2.a. Or use the nonpreferred method described in Note .

Notes continued on the next page

.8. (continued)

otes in reference to Figure -18 and Figure -19 (continued).

2. Service Disconnect Enclosure:

- a. Extend the neutral conductor from the meter panel to the service disconnect enclosure and terminate it to a grounded (i.e., non-insulated) ground/neutral terminal bus as shown in Figure -18, "Grounding Outside of the Sealed Section Self-Contained Meter," and Figure -19, "Grounding Outside of the Sealed Section Transformer- ated Meter," both above.
- b. The service disconnect switch and its enclosure must be within 10 feet or less from the service termination and metering equipment and within the line of sight.
- c. The grounding electrode conductor's termination point and the ground/neutral terminal bus must be located in the service disconnect and cannot be located in gutters or raceways.

. Equipment Bonding: Install an equipment grounding conductor (EGC) between the PG&E service termination enclosure (e.g., meter panel) and the service disconnect enclosure. The EGC is required in this layout. un the EGC (i.e., bonding wire) through metallic conduit and attach it to the inside of each enclosure. se Myers hub fittings to connect the conduit with the enclosures. These fittings are nderwriters aboratories ( ) certified for bonding and are required to connect the conduit with the enclosures. PG&E and the local authority having jurisdiction must approve the conduit and fittings. The customer bond wire is allowed to terminate in a manufactured bond lug installed at the bottom of meter panel.

. Conduit: The conduit diameter size connected to the meter panel must be equal to, or larger than, the diameter of the maximum knockout manufactured in the panel. The approved bonding hubs should not extend out past the edges of the meter panel.

Table - Grounding Re uirements for All Mounted Panels

	Material			
	Neutral ire	Customer Cables to Disconnect S itch	Ground Rod and ire	ond ire
llo ed to be Terminated Inside Sealed Sections of Meter Panel	es	es	o	es

Temporary Service

1 Temporary Service sing Permanent Service Panels

To lessen the potential for damage by staples and nails during the construction phase, applicants must use only galvani ed rigid steel (GRS) in locations where permanent service facilities will be installed and/or energized before completing the wall. The steel protects the conduit and/or cables from damage.

**.9.1. (continued)**

Applicants also must protect their grounding conductors against mechanical damage by rigid steel conduit or armor cladding that runs from the main panel to a subterranean location and is embedded in concrete (e.g., garage). The service facilities and the wall must be a permanent and stable structure. If couplers are installed they must be of the same type (GRS) as the conduit. If transitioning from steel to rigid plastic the coupler must not reduce the internal diameter of the conduit. Refer to the steel and steel to plastic couplers in [umbered Document 062288, “ nderground Conduits,”](#) located in [Appendix C](#).

For the installation requirements of G S conduit and couplings, see [Section , Subsection . . .1., “Galvanized igid Steel Conduit and Couplings,”](#) on Page -12.

The service panel and facilities must meet all PG&E and local jurisdiction requirements. The service facilities must pass inspection by a PG&E inspector before being energized.

As an alternative to constructing a permanent wall to support the meter panel, two flat steel bars that are each a minimum of 1/ inch thick and inches wide may be permanently cemented into the foundation and run vertically parallel with both sides of the meter panel. The flat side of the steel bars must face the sides of the panel, be long enough to reach the top of the panel, and be permanently secured to the panel.

2 Temporary-Service Metering Pedestal

Applicants must coordinate the connection of pedestal service conductors with PG&E project coordinators. Before installing temporary-service metering pedestals, applicants must obtain any inspections and permits that are required from the local authority having jurisdiction.

Applicants must install temporary-service metering pedestals as shown in Figure -20, “Temporary-Service Metering Pedestal,” on Page - 0.

.9.2. (continued)

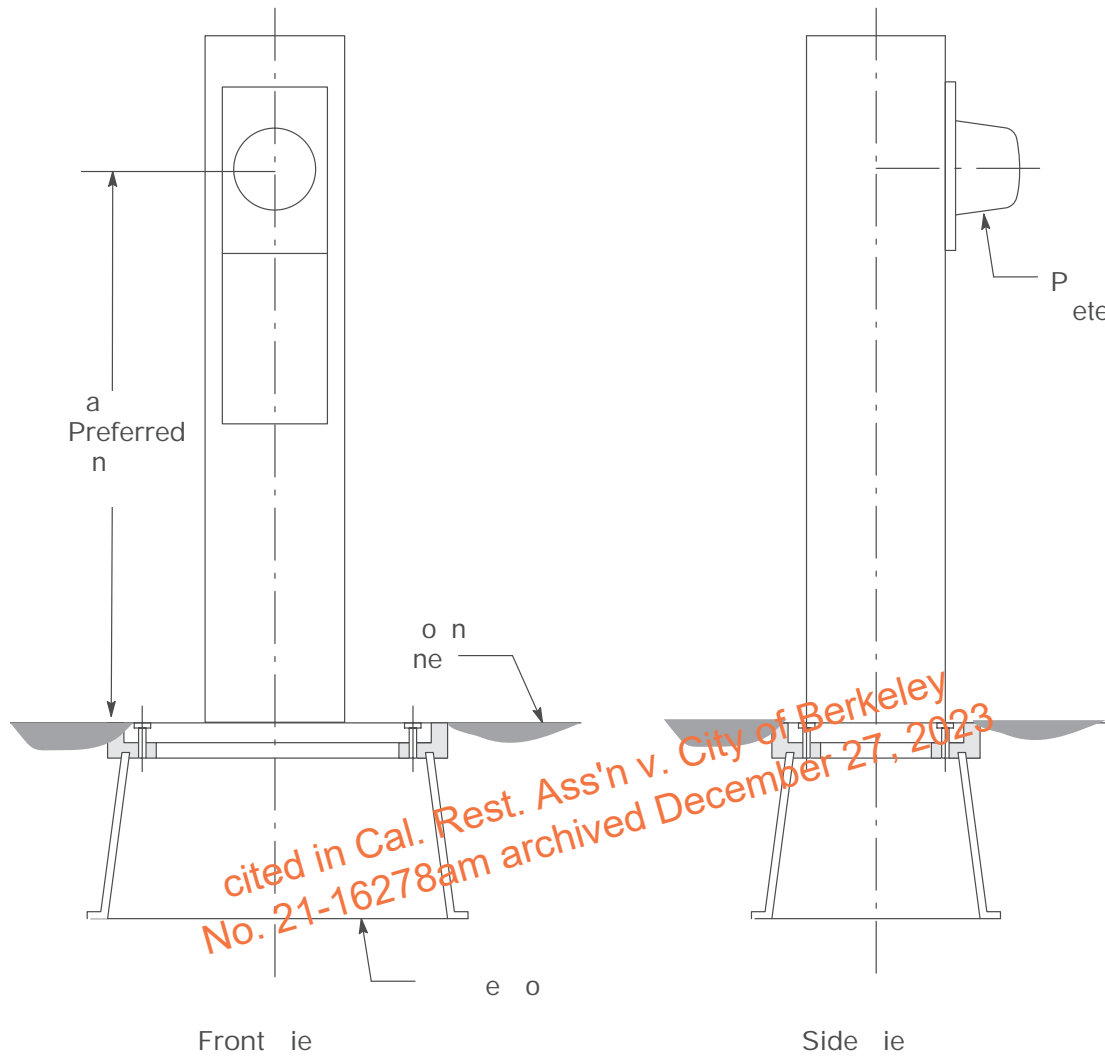


Figure -20  
Temporary-Service Metering Pedestal

### Temporary Plug-In Service

The local inspection authority having jurisdiction must approve all of the permanent service connections to the main service disconnect before an applicant installs a temporary service adapter. Additionally, the local authority having jurisdiction must approve the applicant's plan for installing and using temporary service adapters.

Applicants must install temporary plug-in service as shown in Figure -21, "Plug-In Temporary Service," and Figure -22, "Typical Plug-In Adapter," below.

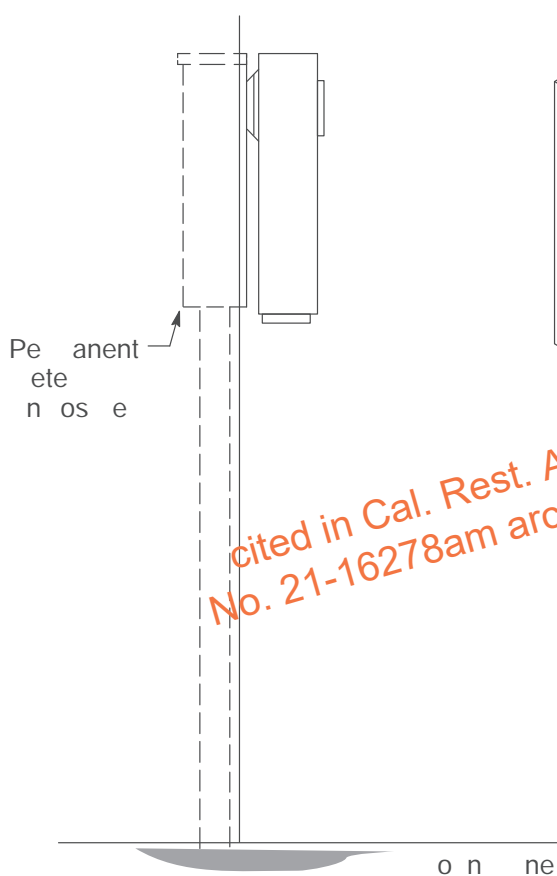


Figure -21  
Plug-In Temporary Service

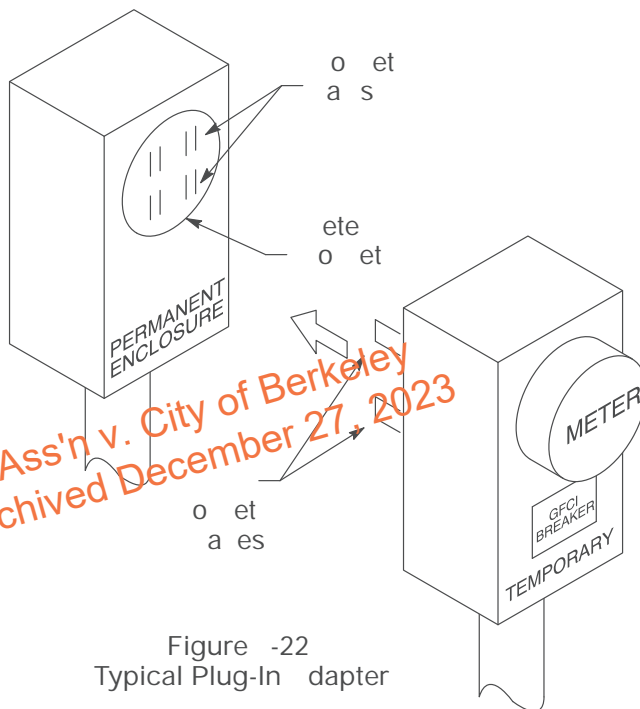


Figure -22  
Typical Plug-In adapter

Note: The connection attaching the adapter to the permanent enclosure

*cited in Cal. Rest. Ass'n v. City of Berkeley  
No. 21-16278am archived December 27, 2023*



## 10 Connecting Non-utility Power Sources to Utility Services

By enacting California Health and Safety Code, Division 10, “Environmental Health,” Part 1, “Miscellaneous Requirements,” Chapter, “Electrical Hazards,” Sections 1190 through 119090, the legislature of the state of California intended to prevent electricity generated by permanent or portable electric generators from backfeeding into a utility’s electrical distribution system. In addition, California Code of Regulations (CCR) Title 8, Section 20.9, “Backfeeding or Interconnection,” says that electrical power sources, both permanent and temporary, can not be connected to a premises’ wiring system, or parts of such a system, unless positive means are used to prevent electricity from being transmitted beyond the premises’ wiring system, or beyond any intentionally segregated parts of such a system.

EXCEPTION: The service utility can authorize an interconnection.

A positive means is defined in this CCR subpart as a device that, when used or operated, interrupts or prevents the flow of current to or from the electrical system. Also, a positive means provides the device operator or user with a visual or definite indication of the existing condition or state of the electrical system.

PG&E requires customers to notify the company when they are installing generation or using a generator. If installing an applicant-owned and operated generator that operates in parallel (back feeds) with PG&E’s system, or has any battery storage capabilities, the applicant must contact PG&E’s Electric Generation Interconnection (EGI) department by email at [rule21gen@pge.com](mailto:rule21gen@pge.com).

If the applicant-owned and operated generator will never operate in parallel with PG&E’s system or is fueled by natural gas connected to PG&E’s gas meter, the applicant must contact the PG&E Business Customer and Innovation Center at 800-821-8218 for the interconnection requirements specific to the location where it will be used.

Customers installing applicant-owned and operated generators that will not run in parallel with PG&E’s system, do not have battery-storage, and are not fueled by natural gas connected to a PG&E gas meter must call the PG&E Customer Service line at 800-821-8218 to have their generators noted on the service point at their premises.

Also, for interconnection requirements, applicants should refer to PG&E’s Distributed Generation Interconnection Handbook, which is available on PG&E’s Internet website at <http://www.pge.com/mybusiness/customerservice/nonpgeutility/generateownpower/distributedgeneration/interconnectionhandbook/index.shtml>

NOTE: See Numbered Document 0609, “Disconnect Switch Requirements for Distributed Generation Customers,” located in Appendix C, when customer generation systems are installed on their premises.

## 10.1 Specific Interconnection Requirements for Services up to 100 Volts

Residential and small commercial applicants with generating facilities on their premises who want to take advantage of PG&E’s standard net energy metering (NEM) program must meet the following requirements.

.10.1. (continued)

Requirements for Small Power Generators (Qualifying Facilities) and Co-Generation Interconnections Including NEM Interconnection Installations

Table -6 below shows the requirements for an ac disconnect.

Table - Requirements for AC Disconnect Switches

Inverter-based Generators	Phase(s)	AC Disconnect Required
One-Phase or Three-Phase Single-Phase	Single-Phase	Yes
Non-Inverter-based Generators	Phase(s)	AC Disconnect Required
One-Phase or Three-Phase Single-Phase	Single-Phase	Yes

For a three-phase disconnect, the disconnect must be installed on the line side of the meter.

A fusible ac disconnect switch is required for generator interconnections ahead of the main breaker (line/supply side connection) and after the meter. Also required is an engraved placard (signage), indicating there is a line/supply side connection, installed on the metering equipment. For specific requirements, refer to [umbered Document 09 6 0, "Supply Side Interconnection Requirements for Distributed Generation."](#)

A nonfusible ac disconnect switch may be installed if the generation is connected to a dedicated, alternative generation breaker that came manufactured (e.g., solar ready) with the meter panel. For specific requirements, refer to [umbered Document 09 6 0](#), located in [Appendix C](#).

As specified in [Electric Rule 21, "Generating Facility Interconnections,"](#) and as required by PG&E, the generating facility must have an ac disconnect switch that meets the requirements described in [umbered Document 060 9](#) and listed below.

- Easily accessible by PG&E, when requested.
- Manual and gang operated. Lockable in the "open" position.
- Allows visible verification that an air-gap of separation has occurred.
- Located 10 feet or less from PG&E's electric meter at the point of common coupling or interconnection and is seen easily, in line of sight, from the panel.

.10.1. (continued)

- Permanent, approved sign(s) attached at PG&E’s electric revenue meter’s point of common coupling. A map showing the location of the ac disconnect switch also may be required.
- Installed in a safe and acceptable location (either outdoors or in a meter room) that meets the same location, height, and working space requirements as a meter panel. The height is measured from the ground to the top of the switch.
- The disconnect switch must be installed to only isolate the customer generation sources and must not disconnect customer loads.
- The disconnect switch must not be electronically controlled from a remote location to close in the switch to the “On” (energized) position.

For additional information on disconnect switches and distributed generation requirements, see PG&E’s [Distribution Interconnection andbook](#).

Virtual Net Energy Metering – NEM (NEM )

This program allows qualified participants to install a single solar system to cover the electricity load of both common and tenant metered areas connected at the same service delivery point.

This [Electric Rate Schedules](#) table helps housing owners allocate a solar system’s electricity to tenants enabling residents to receive the direct benefits of the building’s solar system without requiring the generator to be physically connected to each billing meters.

Refer to [Numbered Document 0 62 9, “ Virtual Net Energy Metering Installations.”](#) found in [Appendix C](#), which explains the requirements for NEM installations and illustrates the various metering and connection options for NEM projects. Check the PG&E [Electric Rate Schedules](#) website for the latest information on this program.

C Requirements for Generators That are Not Permanently Connected (i.e., Temporary Connections)

Portable electric generators must be connected as described in the [California Health and Safety Code, Division 10 , Part 1 , Chapter , Section 1190 \(b\)](#). This code says that any portable electric generator that can be connected temporarily to an applicant’s electrical system, and that is supplied typically by an electrical corporation or state or local public agency, can be connected only after separating the applicant’s electrical system from that of the electrical corporation or state or local agency.

This rule applies to any generator connected as a temporary (i.e., nonroutine, nonscheduled) or emergency source of power.

Connect any portable electric generator that is used periodically as a source of power, either on an as-needed or scheduled basis, as described in Subsection .10.1.D., on Page - . An example would be a generator used to provide backup power for equipment maintenance.

*Filed in Cal West Ass’n v. City of Berkeley, No. 21-16278am archived December 27, 2023*

## .10.1. (continued)

- D Requirements for Generators That Are Connected Either Permanently or Periodically to an Electrical Service and Tested on a Planned, Routine, or Scheduled Basis, but Do Not Operate in Parallel With the PG&E System

Generators falling under this category must have a disconnect switch that is accessible to, and in a location approved by, the serving utility.

These generators must be connected as described in PG&E's [Electric Rule 2, "Description of Service," Item E.6](#), and in the [California Health and Safety Code, Division 10, Part 1, Chapter , Section 1190 \(c\)](#).

These rules state that any electrical generator that can be permanently connected to an applicant's electrical system must be connected only by means of a double throw switch (see Figure -2 on Page - ). This switch isolates the applicant's electrical system from that of the electrical corporation or state or local agency.

EXCEPTION: Generators that are designed to run in parallel with the servicing utility's system, and that are approved by that utility, are exempt from these rules.

The double throw switch may be either a manual or automatic transfer switch meeting the requirements of [Standard 1008, "Transfer Switch Equipment."](#) The switch may be an integral part either of the generator assembly or of the service facilities, and must be approved by the authorities having jurisdiction.

Please visit "[Electric Generator Safety](http://www.pge.com/generator/)" (<http://www.pge.com/generator/>) for more information.

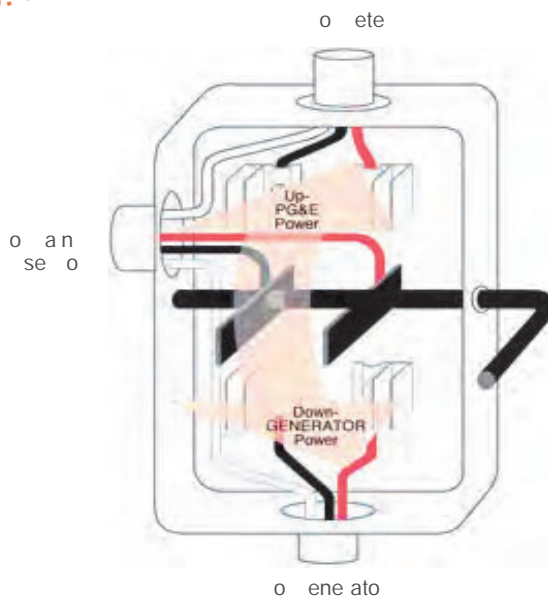


Figure -2  
Transfer Switch

NOTE: Ensure that the transfer switch is installed after the meter panel on the customer's side, not before the meter panel on PG&E's side.



Generator

## .10.1. (continued)

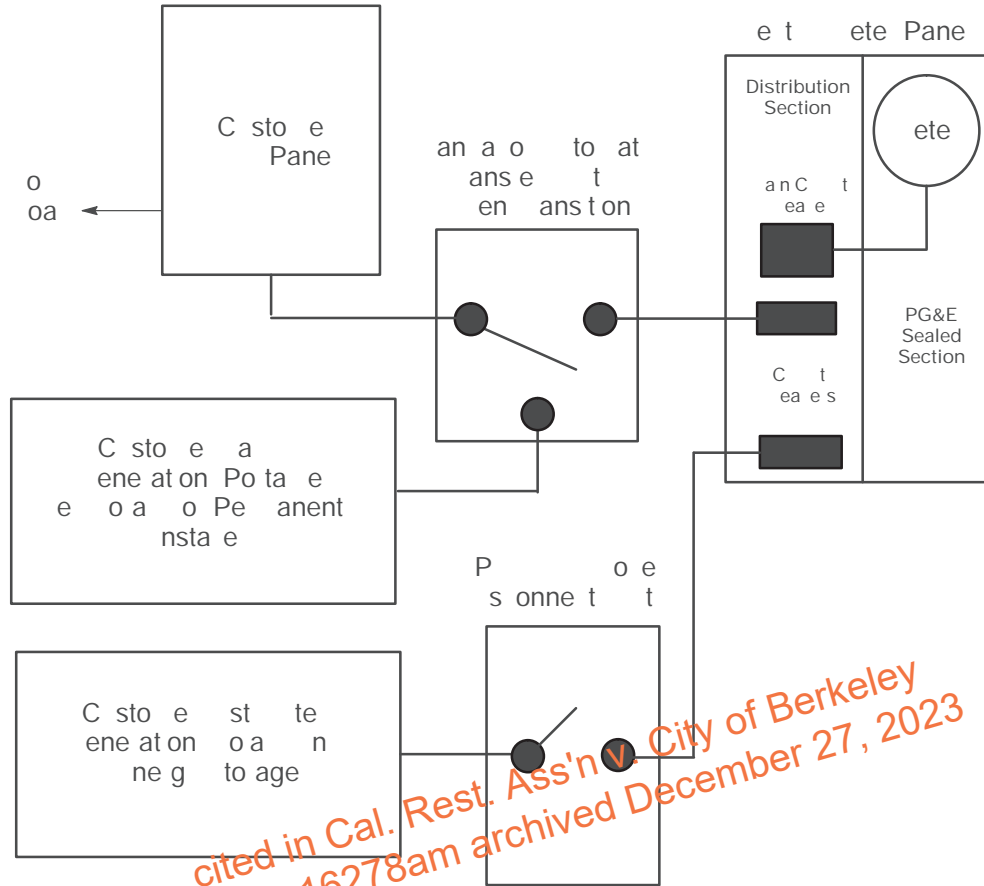


Figure -2  
S D Manual Transfer Switch

Notes in reference to Figure -2 .

1. Ensure that the automatic or manual transfer (safety) switch is a double-pole, double-throw switch certified to Underwriters Laboratories (UL) Standard 1008, "Transfer Switch Equipment."
  2. Do not reroute or modify line-side (supply) cables or busing coming from the meter compartment to the distribution section of the panel. Do not modify PG&E-sealed sections.
- . A disconnect switch is required to be installed between the transfer switch and meter panel. The disconnect switch may be exempt from being installed if one of the following conditions are met.
    - If a manual transfer switch is installed, the blades have a visible air gap when switched to the "off" position.
    - If an automatic transfer switch is installed, the transfer scheme is a "break before make" open transition.
  - . For some meter panels, a disconnect switch may need to be installed between the transfer switch and customer generation.

## .10.1. (continued)

- E Requirements for NEM Revenue Metering with a -wire System at the Point of Common Coupling

EM revenue metering that has a -wire system at the point of common coupling also must have a EM meter panel configured for a -wire system (three phases and a neutral).

When the normal source of voltage supplying PG&E co-generation metering potentially can be interrupted, PG&E, at its option, may install metering with an auxiliary source of power at the applicant's expense.

- F Requirements for Generators Powering 10 k (or less), Stand-Alone, Field-Installed Telecommunication Facilities and Special Applications

Applicants can own 10 k (or less) generators used for stand-alone, field-installed, telecommunication facilities and special applications.

However, PG&E field personnel perform maintenance and routine testing on electric supply and meter facilities, and must be able to perform these functions even when applicants are unable to be present.

Applicants must provide a positive means to prevent their generators from backfeeding into the utility system. This requires installing special equipment, as described in the PG&E [Distribution Interconnection Handbook](#).

Usually, these equipment installations are performed in the field. The generator or alternate power source either is integrated with or is made a part of stand-alone equipment and metering facilities. For example, an applicant could install a double throw switch to isolate his or her equipment and power supply and prevent electricity from flowing into the electric metering and supply system.

## 10.2 Warning Statements and Labels for Interconnected Services

[California Health and Safety Code, Division 10, Part 1, Chapter, Section 119080\(a\)](#), requires that every manufacturer of a portable or permanent electrical generator that is capable of being connected either permanently or temporarily to a commercial, industrial, or residential structure's electrical system include a warning statement.

The warning statement must be published in the generator's instruction manual and a legible warning label must be present on the generator. The warning statement must contain the requirement found in [California Health and Safety Code, Division 10, Part 1, Chapter, Section 1190](#), and explain potential electrical hazards that backfeed can create when it flows into a utility's distribution system.

The same warning information must be included in all advertisements offering portable electrical generators.

.10.2. (continued)

California Health and Safety Code, Division 10 , Part 1 , Chapter , Section 119080(b) also requires that portable electrical generators display a legible warning label on a visible surface of the generator. It goes on to say that individuals or public agencies can not sell or rent to another person or public agency, or offer for sale or rent to another person or public agency, a portable generator that does not have a warning labeled displayed on the equipment.

10 Violation

California Health and Safety Code, Division 10 , Part 1 , Chapter , Section 119090, states that violating the requirements of Section 1190 through Section 11908 is a misdemeanor offense, subject to a fine of not more than \$100.00 or not more than 6 months imprisonment.

10 References for Customer Generation

PG&E has numerous requirements for installing portable or permanent sources of customer generation. Customers who install solar, battery storage, and backup generation systems will find useful information and requirements in these documents listed below.

Table -7 Customer Generation References

_____	<u>Some of the elements of the generation of storage</u>
_____	<u>generation installations</u>
_____	<u>elements of the generation</u>
_____	<u>of the generation</u>
_____	<u>of the generation</u>
_____	<u>and</u>

*cited in Cal. Rest. Ass'n v. City of Berkeley  
No. 21-16278am archived December 27, 2023*

11 Plug-In Electric Vehicle Interconnections

Residential customers with Plug-In Electric Vehicles (PEVs) can connect the Electric Vehicle Supply Equipment (EVSE) to their residences under PG&E's existing Electric Schedules. Customers must notify PG&E of the additional electrical load before connecting a PEV. The increased load may require the electric service cables, conduit, and meter panel to be upgraded.

Additional PEV information can be found in PG&E's Electric vehicles website at <http://www.pge.com/electricvehicles/>. For questions regarding PG&E's PEV requirements, please contact the Discover building and renovation services at 800-822-8222.

SECTION  
ELECTRIC METERING:  
RESIDENTI

*cited in Cal. Rest. Ass'n v. City of Berkeley  
No. 21-16278am archived December 27, 2023*

SECTION ELECTRIC METERING: RESIDENTI



SECTION ELECTRIC METERING: RESIDENTI

*cited in Cal. Rest. Ass'n v. City of Berkeley  
No. 21-16278am archived December 27, 2023*

## Section Electric Metering: Residential

---

### 1 Scope

This section of the manual provides the Pacific Gas and Electric Company (PG&E/the Company) service specifications and requirements for residential electric metering. Also, it describes the required locations for those residential meters. This section includes specific information that is not covered by the basic requirements in [Section](#) , “[Electric Metering: General.](#)”

### 2 Residential Electric Service: Specifications and Re uirements

PG&E typically provides electricity for residential and commercial applicants served on a domestic rate schedule with -wire, 120/2 0-volt, single-phase, 60-hertz ( z), alternating current (ac) service. owever, the Company is able to supply -wire, 120/208-volt, single-phase, 60 z, ac service at some locations. This service is limited to a service-entrance rating o 225 amperes (amps). Applicants should contact their local PG&E project coordinators and ask about the type of services that are available for their specific locations.

NOTE: See [Table FM-1, “Service Planning Office and Inspection Desk Contact Information.”](#) at the front of this manual starting on Page iv, for specific contact numbers listed by area.

#### 2 1 Service Classes

The 12 -amp-rated panels are classified as Class 100. The 22 -amp-rated panels are classified as Class 200.

#### 2 2 Test- ypass Facilities

For single-phase residential installations, test-bypass facilities may be provided, but are not required. owever, test-bypass facilities are required for any of the following installations.

- A. Single-family residential Service Class 20 meter, or residential meter panels that are larger than 22 amp, 120/2 0 volt, single phase, -wire.
- B. ive-work homes, housing, or buildings.
- C. esidential meter panels of any size or phase that supply power to elevators.

NOTE: Single-family homes may be exempt if the elevator system has integrated safety features with a backup battery system acting as an emergency power supply.

- D. All common and tenant area meter panels of any size or phase, at multi-residential and live-work buildings with 2 to units, that supply power to fire alarms or equipment, security alarms, laundry rooms, or significant interior lighting. Significant interior lighting is for hallways, storage rooms or areas, and garage areas.
- E. All common and tenant area meters at multi-residential and live-work buildings with 6 or more units.

2 Electric Meter Socket Covers and Seals

When service cable connections are made at residential or nonresidential customer overhead or underground meter panel, termination enclosure, or pull section, whether the service is left energized or de-energized, the following requirements apply.

- A. Cover and seal all meter sockets with an approved blank-off cover (i.e., pie plate) or set the electric meter(s). PG&E material codes for electric meter covers are M2 9 2 and M2 9 9.
- B. Seal all sealable covers on the customer-owned service termination and metering equipment using PG&E-approved seals.

Do not energize meter panels and sockets unless blank-off meter covers are installed on vacant meter sockets.

Meter Locations

An applicant must consult a PG&E project coordinator during the initial construction phase of his or her project to determine the appropriate meter panel and current-transformer cabinet (if installed) location and to ensure that adequate space is provided for the metering equipment. PG&E must review and approve all meter installations before the meters are installed.

When meters are installed in a confined or enclosed area, applicants must ensure that they design a way for PG&E personnel to read the meters from the outside of the enclosures (e.g., window, opening).

The following four, lettered paragraphs provide location requirements that are applicable to residential metering.

- A. Locate the meters and metering equipment either in outdoor, unfenced areas or mount them on, or recess them in, an exterior building wall. Do not mount metering equipment on, or recess metering equipment in, single family residences or inside garages.
- B. Locate the meters and metering equipment in a meter room that is accessible through an outside doorway.
- C. For a multifamily or residential building, locate the meters and metering equipment in a meter room either on the ground floor or in the basement level (or other acceptable location). The installation must be accessible directly from a public area.
- D. In large, multifamily, multistory, high-rise residential buildings where the walking surface of the highest tenant-occupied floor is over 10 feet high, PG&E may, at its option, approve grouped meter locations on one or more upper floors.
- E. An applicant who plans to install metering equipment on any floor above the ground floor in a multistory building must contact a PG&E project coordinator as early as possible during the initial stages of the project. Except for qualified high-rise buildings, PG&E will not approve of any equipment location that is above the building's ground level.

## 6. . (continued)

F. When meters will be installed indoors see [umbered Document 09 68](#) , “Smart Meter Electric Network Requirements for Indoor Meter Rooms and High-Rise Buildings,” located in [Appendix C, “Electric and Gas Engineering Documents.”](#)

G. Locate electric meters in the same general area as gas meters when designing single-family residences. For clearance specifications refer to [Section 1, “Electric Metering: General,” Subsection 1.1.1, “Meter Set Clearance Requirements,”](#) on Page 1-16, and [Section 2, “Gas Service.”](#)

## 1 Installing Utility Services to Mobile Homes

A. Typically, PG&E will not supply utility services and/or metering facilities to mobile homes that are located or set up in any area, including a mobile home park, where utility service facilities are attached directly to the mobile home except under the following circumstances.

1. The mobile home is fixed in place (i.e., no running gear or wheels). The mobile home must not be capable of movement.

2. The mobile home is installed on a foundation system as described in [State of California, Title 2, “Housing and Community Development,” Division 1, “Housing and Community Development,” Chapter 2, “Mobile Home Parks and Installations,” Article 1, “Minimum and Commercial Modular Installations and Facilities,” Section 1, “Foundation Systems.”](#)

B. PG&E will make an exception and install utility services to a location where mobile homes may be moved, including mobile home parks, under certain, specific conditions.

1. The mobile homes must be served by meter pedestals or other PG&E-approved services and the meter facilities must be installed at a fixed location.

2. Applicants are responsible for connecting their mobile homes to those fixed locations and to the meter pedestals or other utility facilities.

See [umbered Document 0 2 21, “Electrical Service Requirements for Mobile Home Developments,”](#) for more information and for specifications. This PG&E document is included in [Appendix C, “Electric and Gas Engineering Documents,”](#) and also in PG&E’s [Electric Underground Construction Manual, Book 1.](#)

## Services

## 1 Single Meter: Underground Service

Services, 0 amps Through 22 amps, Single Phase

Figure 6-1, “Typical Underground Service-Termination Enclosure, Combination Meter-Socket Panel (Residential, 0 Amps–22 Amps),” on Page 6- , illustrates a single, underground, residential, single-phase meter panel (i.e., terminal for a 120/208-volt service and terminal for a 120/208-volt service).

The numbered items below describe the applicant’s requirements when designing these types of underground services.

1. Design the socket and enclosure for underground service conductors.
2. Ensure that enclosures designed for either overhead or underground service entry meet all of the requirements for both types of service.
3. Ensure that all cable-termination lugs are suitable to use with both aluminum and copper conductors. The lugs must be compatible with a range of conductor sizes.

The minimum conductor size for services up to 12 amps is 6 American wire gauge (AWG) to 10 AWG. The minimum conductor size for services rated from 16 amps to 22 amps is 2 AWG to 26 thousand circular mils (kcmil).

Use separate, independently supported, service-termination lugs that extend from the socket, and connect to it, using a bus bar. Provide a minimum radial clearance of 1-1/2 inches between the hot bus terminals and the ground or neutral surfaces. The termination facilities cannot be side- or angle-mounted in relation to the front of the panel.

4. Ensure that the socket enclosure has a separate lug in the sealable section. Use this lug exclusively for terminating PG&E’s neutral conductor. If the neutral terminal is insulated from the enclosure, PG&E will provide the applicant with a bonding screw or jumper.
5. Ensure that the applicant-owned wiring that extends from the distribution section (i.e., branch circuits) does not pass through the sealable section(s).
6. Locate the applicant’s service-grounding electrode conductor outside of the sealable section and design it to permit the applicant’s grounding system to be isolated easily from PG&E’s neutral, when necessary.

6. .1. (continued)

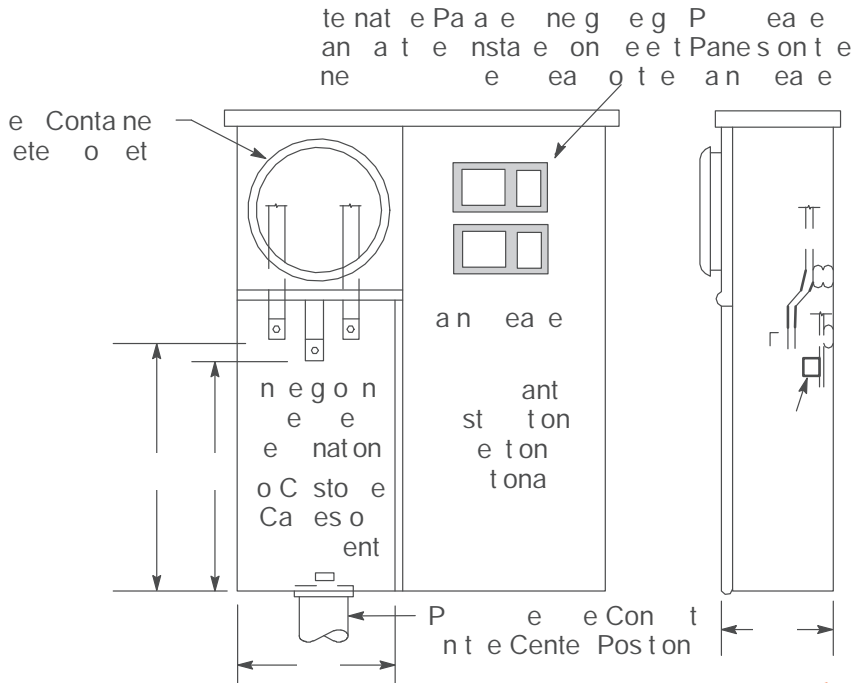


Figure -1  
 Typical Underground Service-Termination Enclosure, Combination Meter-Socket Panel  
 (Residential, 0 mps-22 mps)

Notes in reference to Figure 6-1:

1. These panels are allowed with or without a manufactured-installed alternative energy breaker on the line (supply) side of the main breaker.

Table -1 Residential (0 mps-22 mps) Enclosure

Rating in mps			N		Conduit
to					
to					

Services, 22 mps Through 20 mps, 120/200 volts,  
 Single Phase, Residential

Figure 6-2, "Typical Service-Termination Enclosure, Combination Meter-Socket Panel for a Class 20 Meter (Residential, 120/200-volt, 226-Amp Through 20-Amp Service)," on Page 6-6, illustrates a single, underground, residential, single-phase, 120/200-volt, Class 20-amp meter panel. Applicants must ensure that this panel:

1. Conforms to the requirements for underground-fed, 20-amp metering equipment.
2. Is designed with test-bypass facilities and has provisions for using manual bypass links.

6. .1. (continued)

- . Is marked with either a rating of “ 20 Amperes Continuous” or “ 00 Amperes Maximum ( 20 Amperes Continuous).”
- . Is only used with residential services.

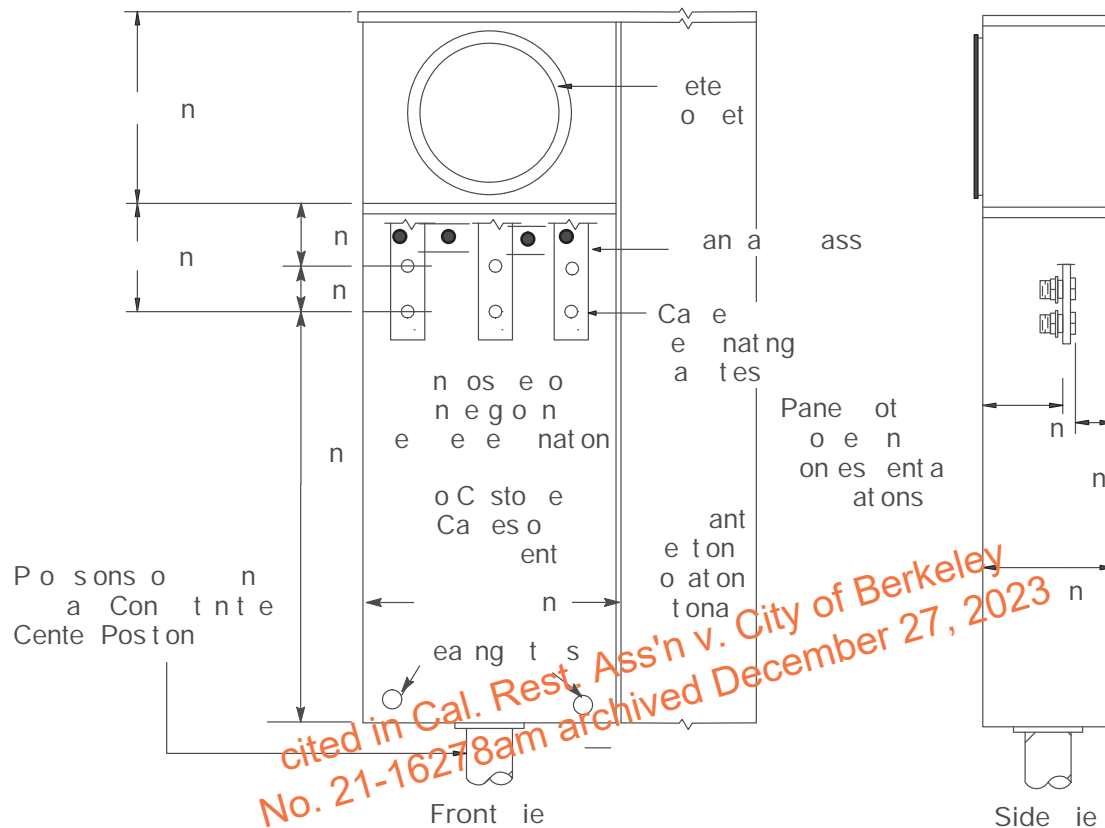


Figure 6-2  
 Typical Service-Termination Enclosure, Combination Meter-Socket Panel for a Class 20 Meter (Residential, 120/208-volt, 22-amp Through 200-amp Service)

- C Services, 201 amps Through 600 amps, Single Phase or 600 amps Three Phase with Current Transformers

Applicants must consult their local PG&E project coordinators when single-phase services exceed 600 amps. Applicants may need to install three-phase service to conform to PG&E’s [Electric Rule 2, “Description of Service.”](#) requirements.

Figure 6-3, “Underground Combination Meter and Current-Transformer Cabinet (201 Amps– 600 Amps 1Ø or Ø),” on Page 6-3, illustrates a single-metered, underground, residential meter panel.

Figure 6-4, “Typical Underground, Separate-Bused, Current-Transformer Cabinet and Safety-Socket Meter Box Assembly, 201 Amps– 600 Amps, Ø and 201 Amps–600 Amps, 1Ø,” on Page 6-8, illustrates how service and metering components can be separated into individual enclosures.

NOTE: See [Section 9, “Electric Metering: Components.”](#) for details about the components in Figure 6-3 and Figure 6-4.

6. .1. (continued)

Applicants must ensure their conductors are installed before PG&E installs the current transformers. Also, applicants must ensure that their service-entrance conductors and equipment meet the following requirements.

1. The current transformer mounting base must include termination bolts, Belleville washers, and nuts on the line and load sides necessary to connect the PG&E current transformers and service conductors to the line side.
2. The applicant conductors must be terminated on the top (load side) of the current-transformer mounting base or termination enclosure busing. Applicant conduit must not be installed within 2 inches of the PG&E service entrance conductors. Applicant conductors must be routed properly to ensure they do not cross in front of or behind the PG&E conductors and conduit and do not obstruct the PG&E current transformers or test switch areas.

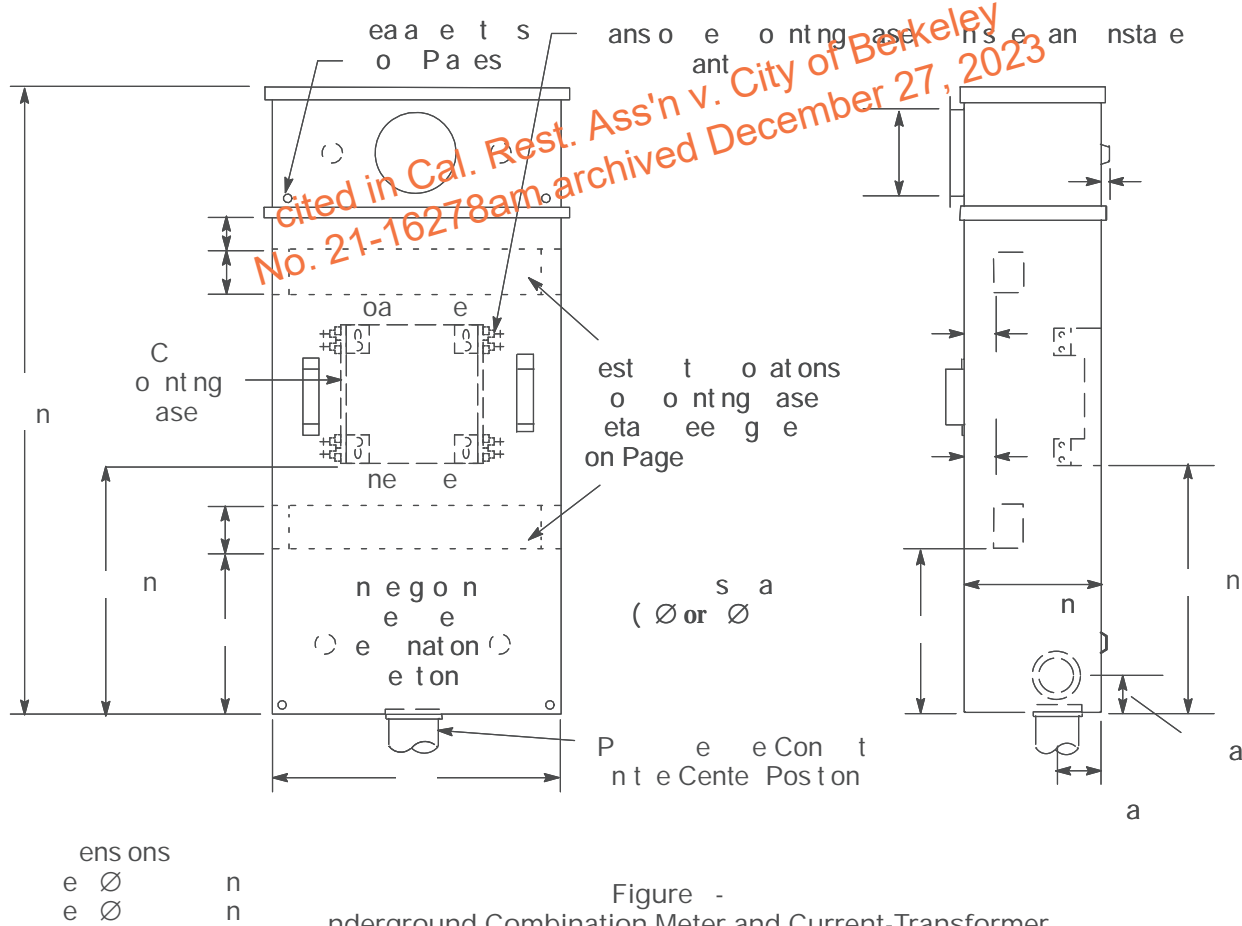


Figure -  
Underground Combination Meter and Current-Transformer Cabinet (201 mps- 00 mps, 1Ø or Ø)



6. .1. (continued)

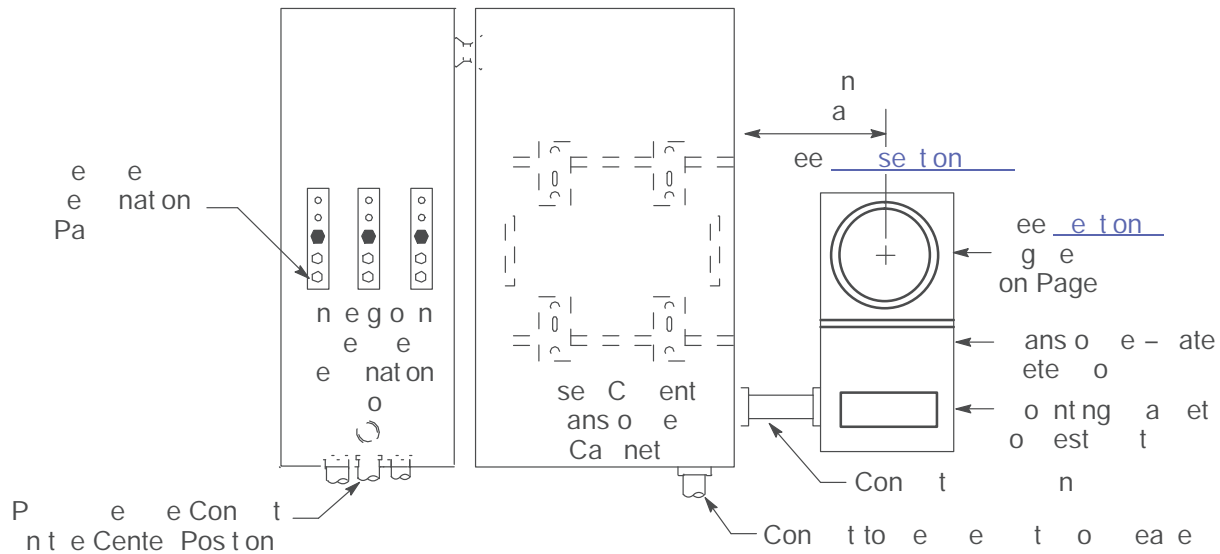


Figure -  
 Typical nderground, Separate- used, Current-Transformer Cabinet and Safety-Socket  
 Meter o ssembly (201 mps- 00 mps, Ø and 201 mps- 00 mps, 1Ø)

2 Single Meter: Overhead Service

Services, 0 mps Through 22 mps, Single Phase

Figure 6- , "Combination Meter Socket oad Center," on Page 6-9,  
 illustrates the -terminal, 120/2 0-volt and -terminal, 120/208-volt  
 overhead service and meter panel. This panel is only allowed for  
 residential customers with a single-phase overhead service. Individual  
 meter socket boxes that do not have a main breaker as part of the panel  
 are not allowed.

Enclosures designed for a combination of overhead and underground  
 conductors must meet all of the requirements for both types of  
 conductor entry.

Filed in Cal. Rest. Ass'n v. City of Berkeley  
 No. 21-16278am archived December 27, 2023

## 6. .2. (continued)

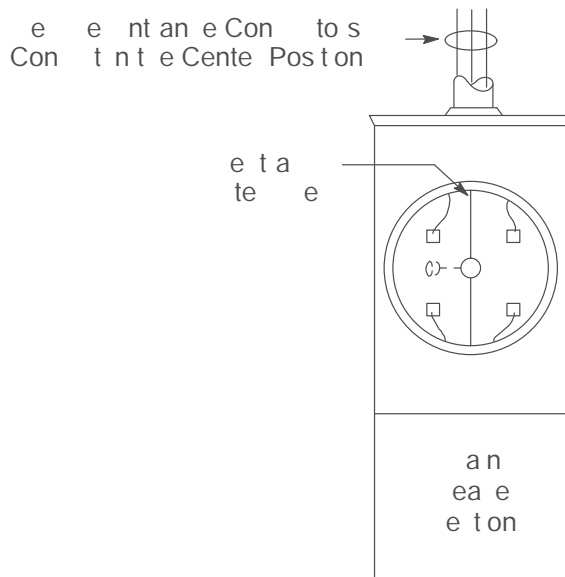


Figure -  
Combination Meter Socket Load Center

notes in reference to Figure 6- .

1. Allowed only for single-family residential homes.

Services, 20 amps Through 20 amps, 120/200 volts,  
Single Phase

Applicants must ensure that this panel:

1. Conforms to the requirements for overhead-fed, 20-amp metering equipment.
  2. Is designed with test-bypass facilities and has provisions for using manual bypass links.
- . Is marked with either a rating of “ 20 Amperes Continuous” or “ 00 Amperes Maximum ( 20 Amperes Continuous).”
  - . Is used only with residential services.

6. .2. (continued)

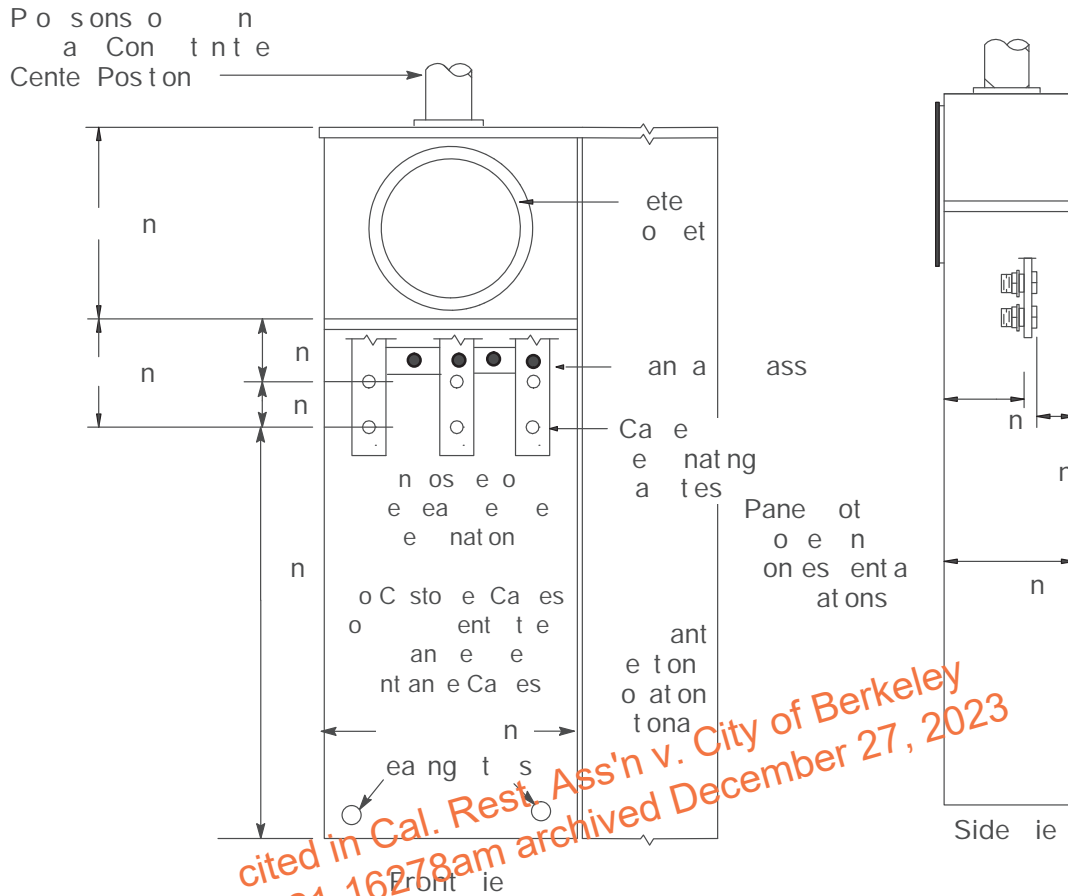


Figure 6-2  
Typical Combination Meter and Service Termination Panel for a Class 20 Meter (Residential, 120/208 Volt, 22 Amp Through 200 Amp Service)

C Services, 201 amps Through 400 amps, Single Phase or Three Phase, with a Current Transformer

Applicants should consult with a PG&E project coordinator before installing single-phase services that exceed 400 amps. Applicants may need to install three-phase service to conform to PG&E's [Electric Rule 2](#) requirements.

Figure 6-3, "Overhead-Fed Combination Meter and Current-Transformer Cabinet, (201 Amps– 400 Amps, 1Ø or 3Ø)," on Page 6-11, illustrates a single-metered, overhead, residential meter panel.

Figure 6-8, "Overhead-Fed, Separate-Based, Current-Transformer Cabinet and Meter Box (201 Amps– 400 Amps, 1Ø or 3Ø)," on Page 6-12, illustrates a single, overhead, residential, single-phase or three-phase service and meter panel with current transformers.

NOTE: See [Section 9](#) for details about the components in Figure 6-3 and Figure 6-8.

6. .2. (continued)

Applicants must ensure their conductors are installed before PG&E installs the current-transformers. Also, applicants must connect the service entrance conductors to the line and load sides of the current-transformer mounting base.

1. The current transformer mounting base must include termination bolts, Belleville washers, and nuts on the line and load sides necessary to connect the PG&E current transformers. See [Section 9](#), for details about these internal components.
2. The applicant's service entrance conductors must be terminated on the top (line side) of the current-transformer mounting base or termination enclosure busing.
3. The applicant's load conductors must be terminated on the bottom (load side) of the current-transformer mounting base or termination enclosure busing.
4. Applicant conduit must not be installed within 2 inches of any corner of the cabinet.
5. Applicant's conductors must be routed properly, ensuring they do not obstruct the PG&E current transformers or test switch areas.

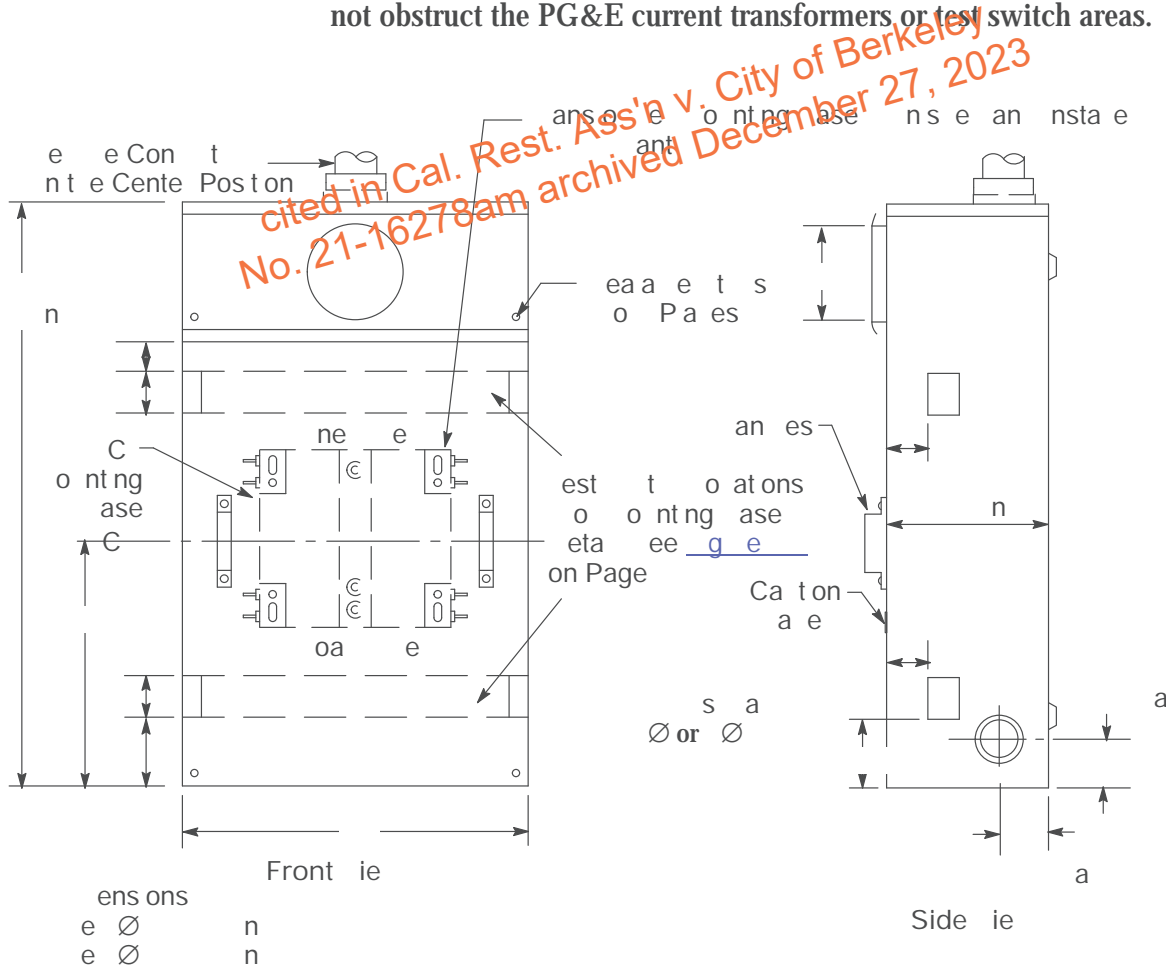


Figure -7  
Overhead-Fed Combination Meter and Current-Transformer Cabinet  
(201 mps- 00 mps, 1Ø or Ø)

6. .2. (continued)

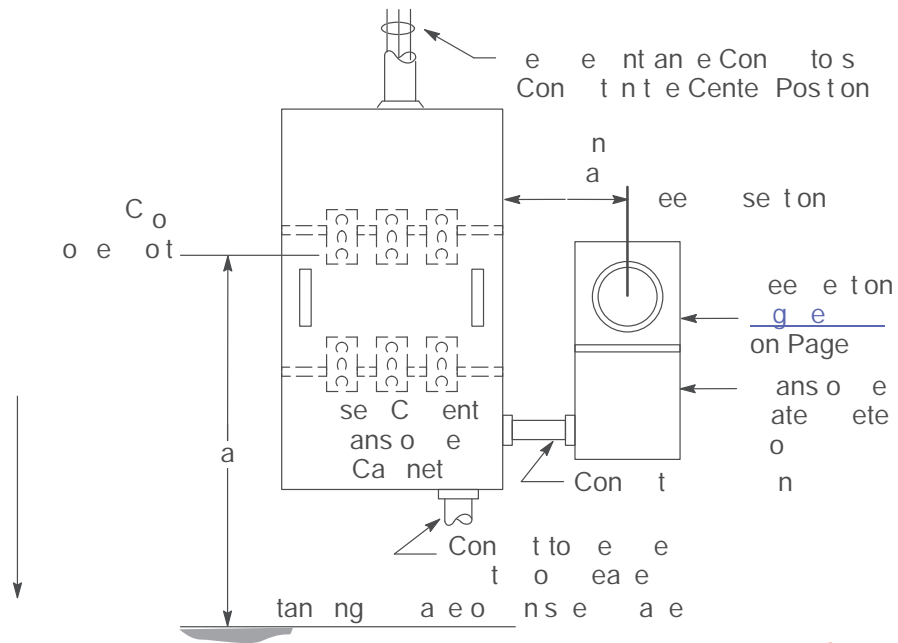


Figure -  
 Overhead-Fed, Separate- used, Current-Transformer Cabinet and Meter o  
 (201 mps- 00 mps, 12 or 0)

Single Meter: Combination Overhead and nderground Service Equipment

Enclosures designed for a combination of either overhead or underground service entrance conductors must meet all of the requirements for both types of conductor entries.

- A. See the requirements in Subsection 6. .1., “Single Meter: nderground Service,” on Page 6- , and Subsection 6. .2., “Single Meter: Overhead Service,” on Page 6-8.
- B. For overhead services, applicants must ensure the service entrance conductors are long enough to provide a bending radius that is equal to or greater than 10 times the diameter of the conductors.
- C. Overhead service panels must have a manufactured raceway built for the panel to isolate the service entrance conductors.

6. . . (continued)

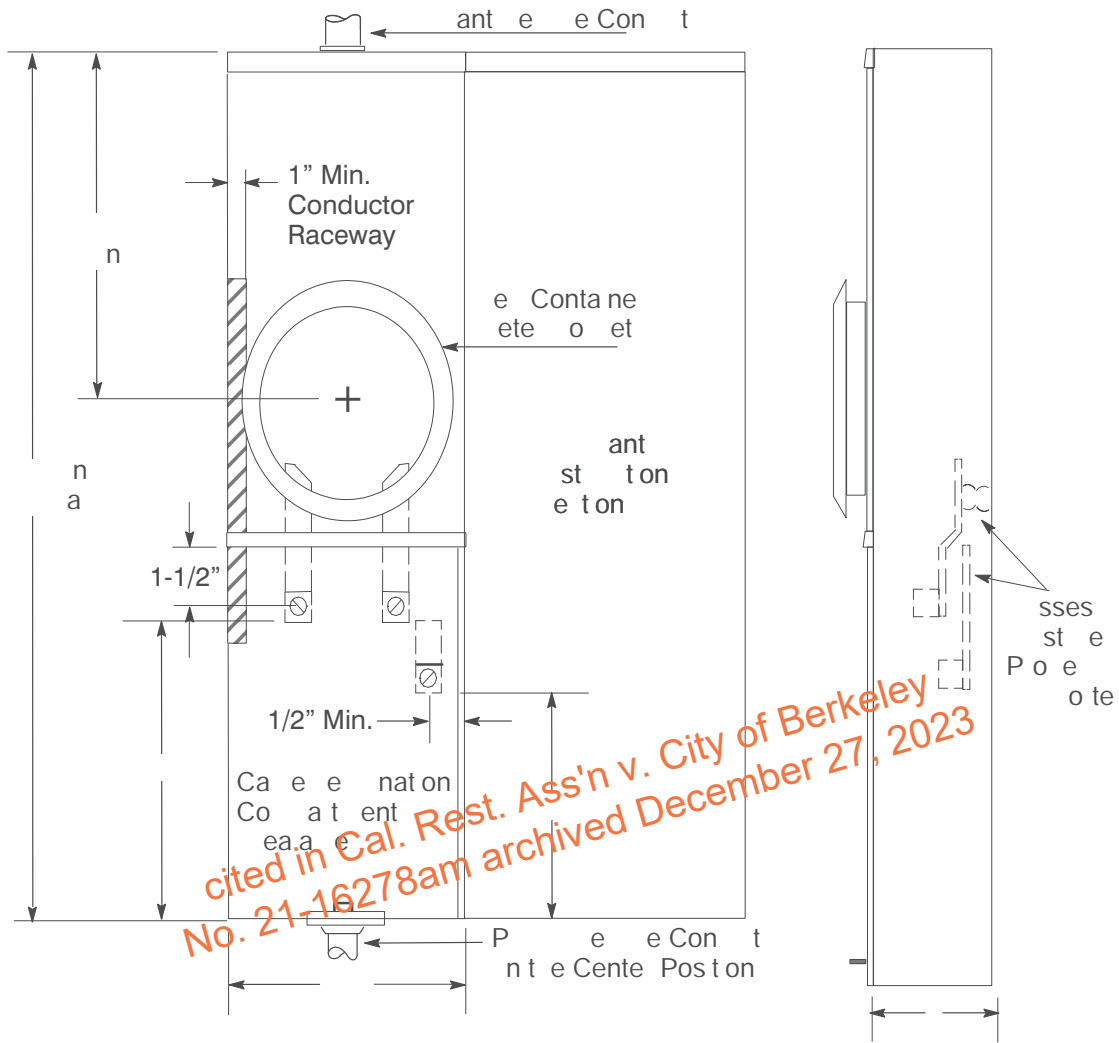
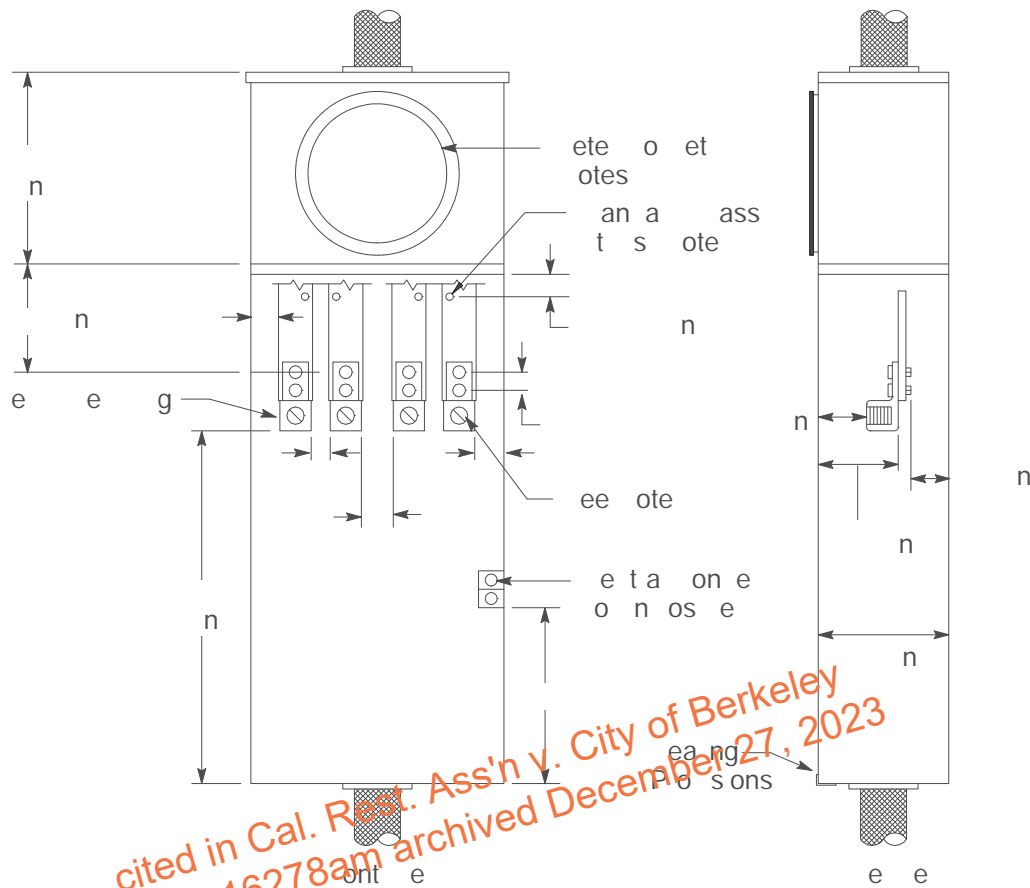


Figure -  
Overhead- or Underground-Fed Combination Meter and Service-Termination Panel  
(22 mps, 1Ø)

Table -2 Residential Combination (O / G) Meter Panel

Rating in mps	N			Conduit Range
	Minimum Dimensions (In Inches)			
		9½	½	

6. . . (continued)



*cited in Cal. Res. Ass'n v. City of Berkeley  
 No. 21-16278am archived December 27, 2023*

Figure -10  
 Overhead or Underground Service-Termination Meter Panel  
 with Manual Bypass Studs ( 20 amps, 120/208 volt, 1Ø)

Notes in reference to Figure 6-10.

1. Ensure that this service equipment is marked with a continuous amp rating of 20 amps. Alternatively, service equipment can be marked "00 amp" (20 amps continuous).
2. Each phase bus section must include 12-2 bypass studs, 1/2 inches in height with 1/2-inch hex nuts (measured across the flat). The studs must have a horizontal spacing of 1-1/2 inch (measured from the centers) between the line- and load-bus sections and must be offset from the line-side termination lugs to permit cable to enter from the top without interfering with the utility-provided manual bypass links.
3. Terminations for service conductors must be aluminum-bodied mechanical lugs with a range-taking capability of 1 American Wire Gauge (AWG) through 600 thousand circular mils (kcmil). The lugs must be secured to ensure vertical alignment. Line-side lugs must be offset from the face of the bus to permit cable to enter from the top. The line and load positions must be identified in 1/2-inch high block letters.

## Multiple Meters

PG&E requires grouped, single-meter installations for multifamily residential buildings.

This requirement excludes row-type condominiums where each unit is considered a single-family residence and is metered individually. Row-type condominiums must meet the applicable metering requirements described in the following subsections.

### Grouped-Meter Installation Capacity Ratings

The information below describes how to determine the ampacity rating of a grouped-meter installation.

1. For installations without a main switch or breaker, the service rating will be the rating of the electrical enclosure or service termination section, pull can, or other service-termination enclosure where PG&E terminates and connects its supply facilities and conductors. Also, see Subsection 1.1 .B. on Page 1-1 .
2. For installations with a main switch or breaker, the rating of the service to be supplied is the rating of the termination section, pull can, service section, or main service switch continuous current rating, typically whichever is greater. Also, see Subsection 1.1 .A. on Page 1-1 .

### Grouped Meter-Socket Spacing

PG&E requires a 2-1/2-inch horizontal and 8-1/2-inch minimum vertical center spacing between meter sockets.

### C Individual Meter Sockets with Wiring Raceway/Gutters

PG&E accepts meter sockets with wiring gutters as shown in Figure 6-11, “Overhead Service, Grouped-Meter Installation Without a Main Switch ( 00 Amps Maximum, 1Ø or Ø ), and Figure 6-12, “Underground Service, Grouped-Meter Installation Without a Main Switch,” both on Page 6-16.

PG&E will accept individual meter sockets in combination with a wiring gutter only for an applicant’s service-entrance conductors and only when unmetered service-entrance conductors and metered-load conductors are not installed in the same conduit, raceway, or wiring gutter.

To conserve space and lower equipment costs, applicants should consider installing a combination multimeter, as described in Subsection 6. .D., “Combination Multimeter Installation,” on Page 6-16. Only if applicants are reconstructing or adding to an existing installation can they install a meter trough, as described in Subsection 6. .E., “Meter Trough Installations,” on Page 6-19.



6. . . (continued)

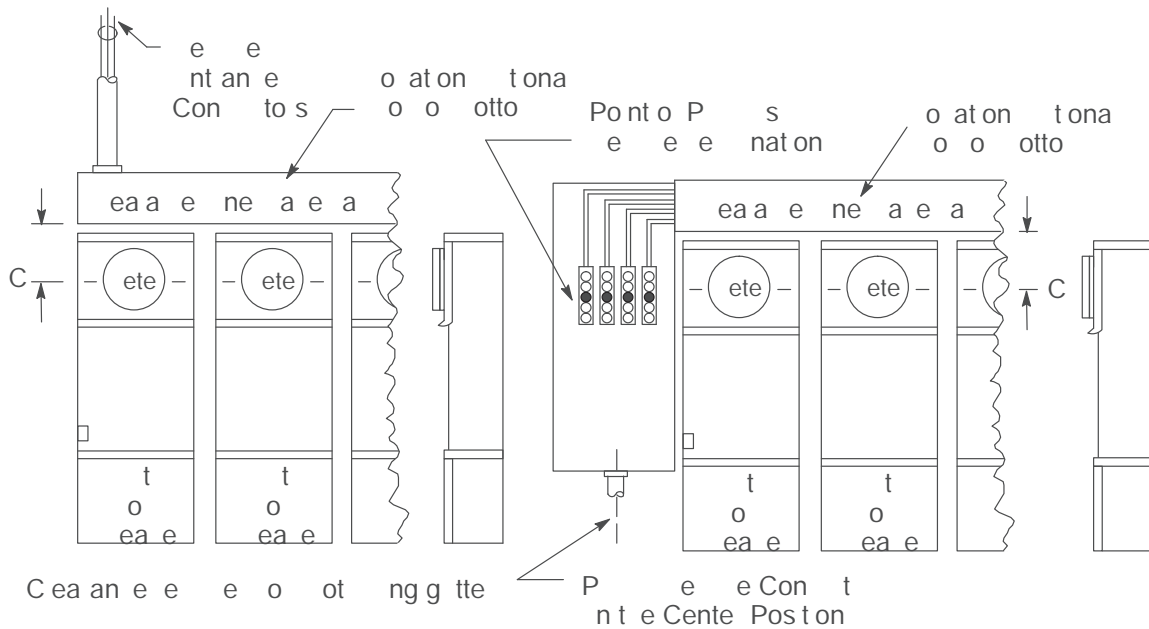


Figure 6-11  
 Overhead Service, Grouped-Meter  
 Installation with a Main Switch  
 (100 mps Main, 1Ø or Ø)

Figure 6-12  
 Underground Service, Grouped-Meter  
 Installation with a Main Switch

D. Combination Multimeter Installation

A combination multimeter installation consists of the following equipment.

- A main switch (if one is installed or required by local jurisdiction)
- Unmetered wiring gutter
- Multiple meter sockets
- An appropriate number of circuit breakers

See [Section 6, Subsection 6.1.1](#), “Main Service Disconnects and Switching Sequences,” on Page 6-1, for more information on disconnects and switches.

Examples of PG&E-approved, combination, multimeter installations are illustrated in Figure 6-1, “Typical, Manufactured, Combination, Multimeter Installation: Seven Meters or More,” on Page 6-1, and Figure 6-1, “Clearances for a Typical, Manufactured, Combination, Multimeter Installation,” on Page 6-18.

Applicants must ensure that all multimeter installations meet the following requirements.

1. Individually meter multiple apartments in one building. Separate metered and unmetered conductors.

6. . . (continued)

2. Use factory (or factory-equivalent), harness-style wiring or bus between the unmetered wiring gutter and the line terminals of each meter socket. Harness-style wiring or bus also must be used between the load terminals of each meter socket and the line side of the corresponding circuit breaker.
3. Ensure that the panels are designed to permit any individual meter socket block or jaw assembly to be replaced. Applicants must not mount more than two meters on a single, removable panel. Removable meter-panel covers must not exceed 6 square feet in area.
4. Ensure that the panel's design and construction meets the clearance requirements provided in Figure 6-1 and in Table 6- , "Dimension Specifications for Multimeter Installations," on Page 6-19.
5. Increase Dimension B, shown in Figure 6-1 on Page 6-18, by the amount that the main switch door, including the operating handle, reduces the clearance when opened 90°.
6. Ensure that panels are removable so that PG&E personnel can perform wiring inspections.

*cited in Cal. Rest. Ass'n v. City of Berkeley  
No. 21-16278am archived December 27, 2023*

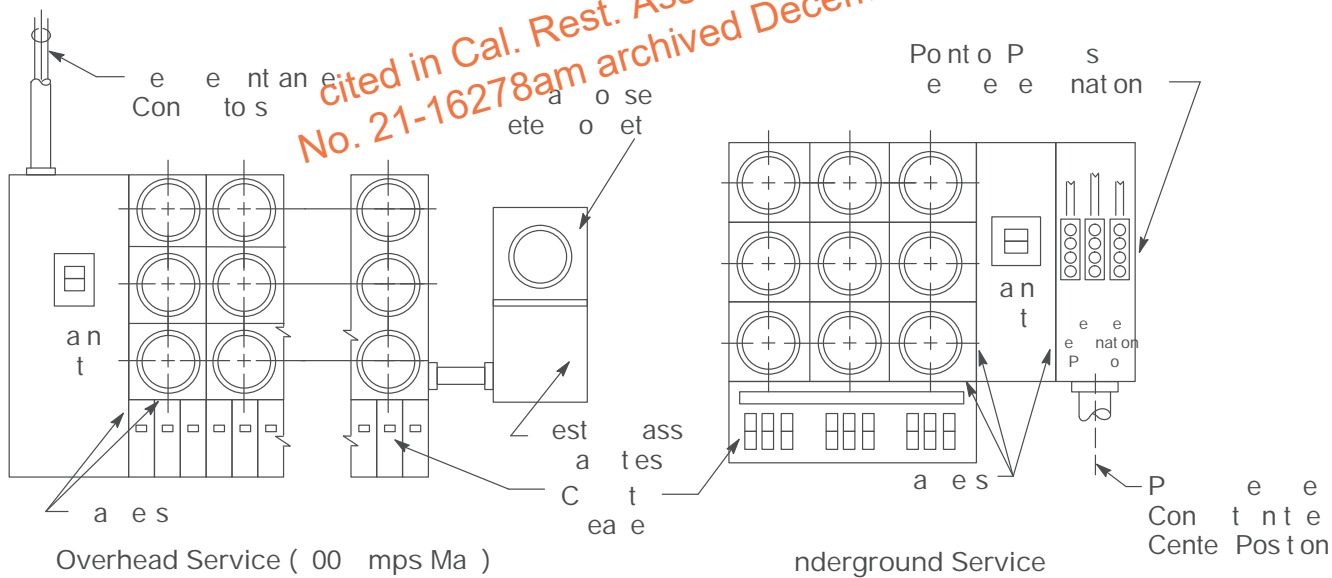


Figure 6-1  
Typical, Manufactured, Combination, Multimeter Installation: Seven Meters or More

6. . . (continued)

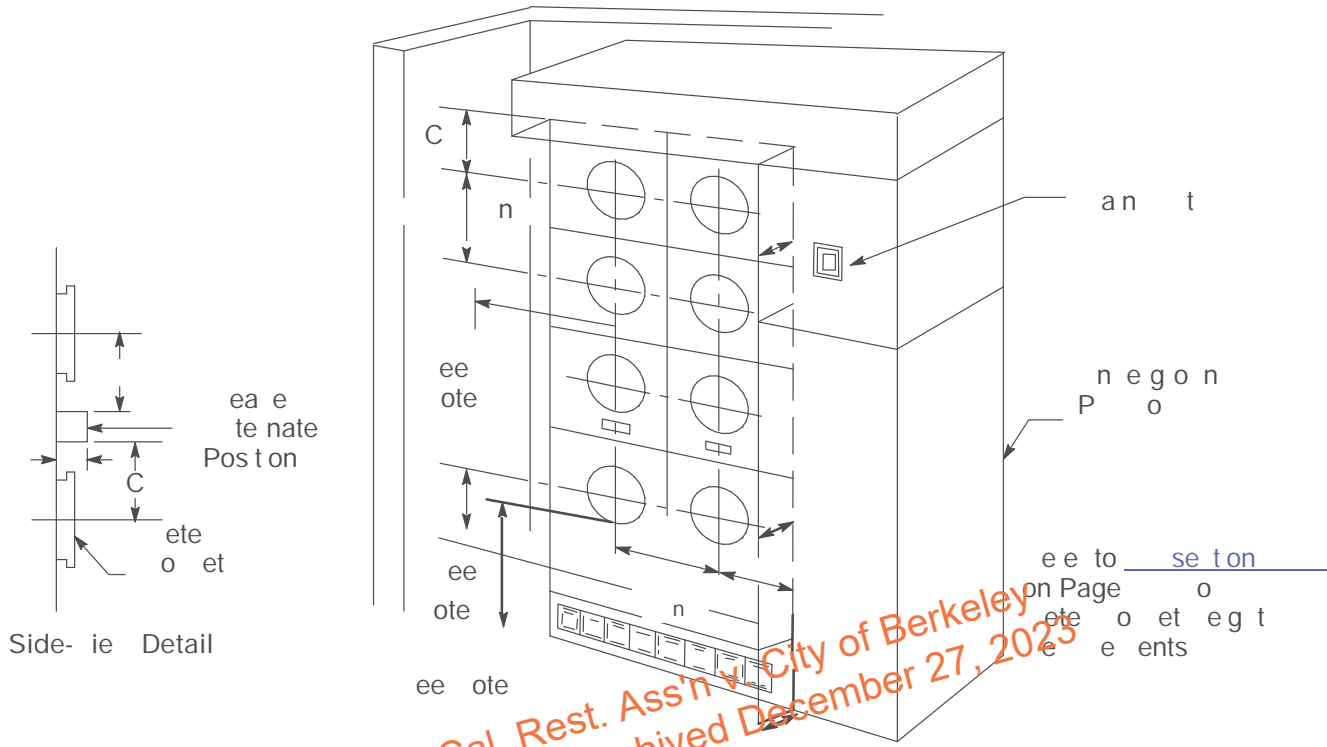


Figure 6-1  
 Clearances for a Typical, Manufactured, Combination, Multimeter Installation

Notes in reference to Figure 6-1 .

1. Where an adjacent wall or other obstruction extends more than 11-inches perpendicular from the face of the meter panel, a 10-inch minimum dimension to the meter socket axis is required. For obstructions extending 11 inches or less from the meter panel, the side clearance must conform to that of Dimension B.
2. The requirements described in Subsection . . . . "Working Space." must be met at all times.
  - . From the floor surface up to the bottom of the lowest row of meter sockets, protrusions, and equipment must not extend past the front face of the meter panels and sockets.

## 6. . . (continued)

Table - Dimension Specifications for Multimeter Installations

Protrusions (in Inches)	C	D	E	
				Minimum Dimension (in Inches)
Protrusion				See Note to Table
Protrusion				
Protrusion				
Protrusion				
Protrusion				

## E Meter Trough Installations

PG&E does not accept new installations of meter troughs but does accept single-meter installations only for reconstructing and adding to existing installations. In addition to meeting the general requirements for meter sockets, applicants must ensure that meter troughs meet the following general requirements.

- Where there are four, five, or six sockets in one trough, the incoming service conductors must terminate on a main bus that is supported independently of the socket jaw assembly.
- The panel design must permit individual, meter-socket blocks or jaw assemblies to be replaced individually. Applicants must not mount more than two meters on a single, removable front panel. Metered and unmetered conductors must be separated, clearly showing that the entire load is being metered.
- The panels must be removable so that wiring inspections can be performed.

6. . . (continued)

Figure 6-1 and Figure 6-16, below, illustrate meter trough installations served by underground or overhead service.

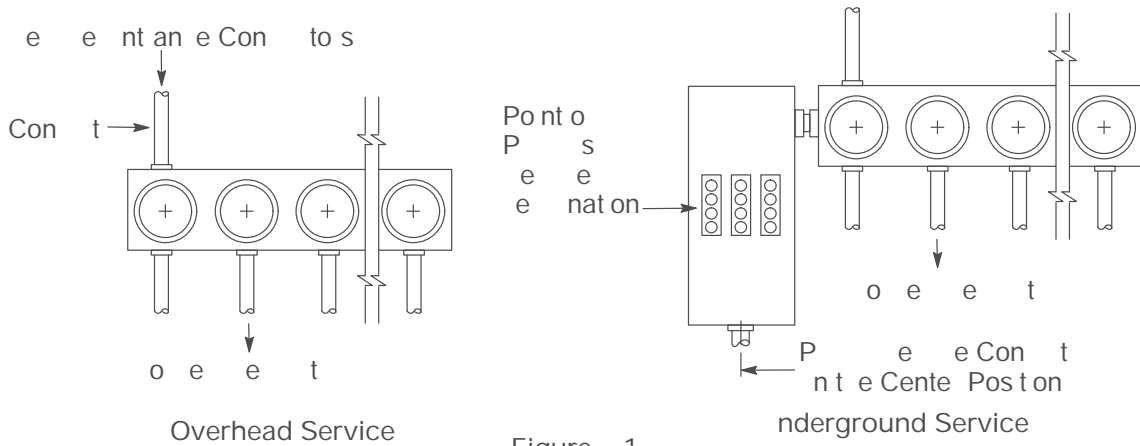


Figure 6-1  
Horizontal Meter Trough Installation: Six Meters or less

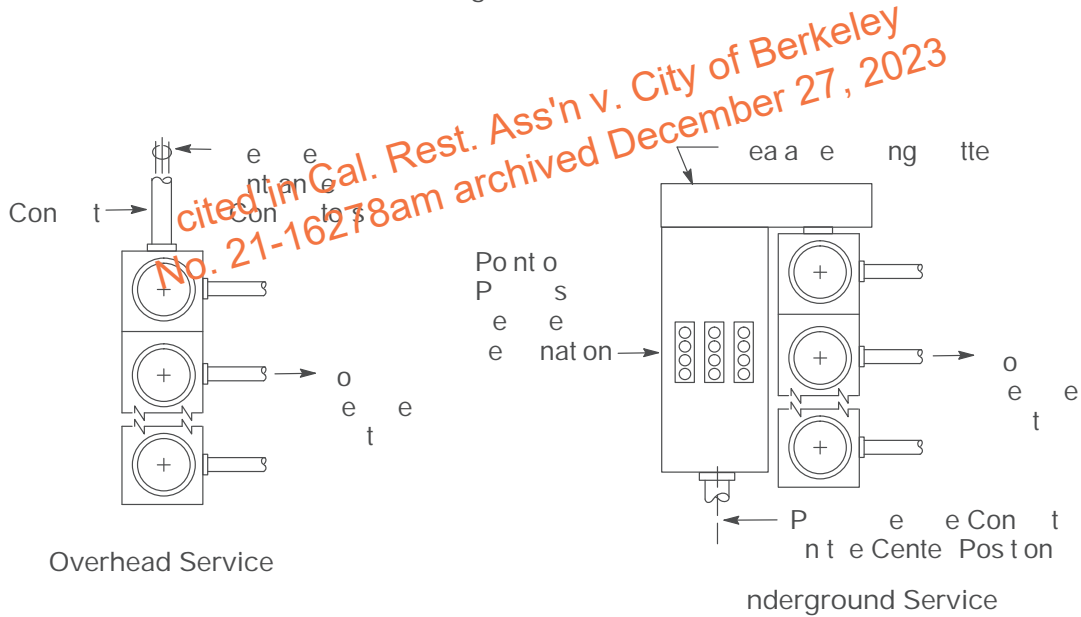


Figure 6-16  
Vertical Meter Trough Installation: Five Meters or less

*cited in Cal. Rest. Ass'n v. City of Berkeley  
No. 21-16278am archived December 27, 2023*

SECTION 7 ELECTRIC METERING: NONRESIDENTI , IND STRI , ND

GRIC T R

SECTION 7  
ELECTRIC METERING:  
NONRESIDENTI , IND STRI ,  
IND GRIC T R

*cited in Cal. Rest. Ass'n v. City of Berkeley  
No. 21-16278am archived December 27, 2023*

SECTION 7 ELECTRIC METERING: NONRESIDENTIAL, INDUSTRIAL, AND STRIP, AND

GRIC TR

*cited in Cal. Rest. Ass'n v. City of Berkeley  
No. 21-16278am archived December 27, 2023*

## Section 7

### Electric Metering: Nonresidential, Industrial, Commercial, and Agricultural

---

#### 7.1 Scope

This section of the manual provides the Pacific Gas and Electric Company (PG&E/the Company) service specifications and requirements for commercial, industrial, and agricultural electric metering. Also, it describes the required locations for these nonresidential meters. This section includes specific information that is not covered by the basic requirements in [Section 6](#), “[Electric Metering: General](#).”

NOTE: Residential meter panels rated for 20 amperes (amps) shown in [Section 6](#), “[Electric Metering: Residential](#),” can not be used for nonresidential (e.g., commercial, industrial, and agricultural) applications.

#### 7.2 Service Specifications and Requirements

The following three subsections describe service specifications and requirements for commercial, industrial, and agricultural electric meters.

##### 7.2.1 Permitted Types of Electric Service

PG&E does not permit overhead service connections in areas zoned for underground service by local ordinance, or where underground service is required by [California Public Utilities Commission](#)- (CPUC-) approved tariffs.

##### 7.2.2 Required Test-Bypass Facilities

Test-bypass facilities are required, regardless of the panel ampacity, for both single-phase and three-phase, nonresidential installations. Applicants must furnish, install, and maintain a meter socket with PG&E-approved, manual, test-bypass facilities. This equipment also is used for the following types of services.

- All three-phase, nonresidential services without exception.
- All single-phase, nonresidential services. See the exceptions in [Subsection 7.2.2](#), “[Required Approvals for Meter Equipment without Test-Bypass Facilities](#),” on [Page 7-2](#).

Refer to [Figure 7-1](#), “[Bused, Safety-Socket Meter Box for Self-Contained Metering \(0 Amps–12 Amps\)](#),” on [Page 7-3](#), and [Figure 7-2](#), “[Bused, Safety-Socket Meter Box for Self-Contained Metering \(126 Amps–200 Amps\)](#),” on [Page 7-4](#).



7.2 Required Approvals for Meter Equipment without Test-Bypass Facilities

PG&E requires an approval before installing meter equipment without test-bypass facilities. If approved, the meter equipment may be exempt only when all of the conditions are met in Item 7.2.A or Item 7.2.B., both below.

- A. Single-phase, nonresidential service when all of the three following conditions are met.
  1. The main disconnect switch’s rating does not exceed 200 amps.
  2. Service to another meter or service will not be interrupted when de-energizing the meter socket without test-bypass facilities.
  3. The metered service is used exclusively for temporary power or nighttime lighting loads.

7.2 Meter Locations

Applicants must consult their local PG&E project coordinators during the initial construction phase of their projects to determine the appropriate meter and current-transformer cabinet locations and to ensure that adequate space is provided for the metering equipment. PG&E must review and approve all metering equipment installations before they are installed.

Additionally, the following specific location requirements apply to nonresidential metering:

- A. Applicants must locate meters on exterior, ground-floor walls or other permanent structures nearest PG&E’s distribution facilities. When outdoor meter locations are not practical, PG&E will approve interior locations if they are accessible during PG&E’s typical working hours and if the interior location meets PG&E’s access requirements, as described in [Section , Subsection . . ., “Electric Meters: General Location Requirements.”](#) on Page - .
- B. Typically, applicants must group meters for multiple-occupancy buildings at one common location however, PG&E allows the following exceptions to this requirement.
  1. PG&E may permit applicants to have individual meters located on their premises if the installations comply with all applicable codes. When buildings contain unmetered wiring, applicants must place that wiring in PG&E-approved conduit and/or in sealable wireways.
  2. In high-rise buildings where the walking surface of the highest occupied floor is over feet high, PG&E has the option to approve grouped-meter locations on one or more floors.

.2. . (continued)

- . PG&E does not permit metering equipment to be located more than 10 feet away and within the line of sight from the service disconnect means, allowing the applicants to separate the metering equipment and service disconnect means remotely. Any exceptions to this requirement must be approved by the local PG&E meter shop. Meter shop employees must approve remote meter locations before applicants locate meters away from (i.e., remote from) the PG&E service termination point. Also, applicants must provide clearances and working space, as described in [Section](#) , [Subsection](#) . ., “[Meter Heights, Clearances, Enclosures, and Protection](#),” on Page -1 , for both the meter and metering transformer installations.

Applicants must supply and install rigid steel conduit for the meter wiring between the meter and the metering transformers. The conduit must be 1-1/ -inch minimum diameter and must be limited to 0 circuit feet with a maximum of three 90° bends, unless sealable, accessible, exposed conduits are furnished.

When meters are separated by more than 0 circuit feet, PG&E requires a special review and approval for the installation.

7 2

Services, 0 mps Through 200 mps, Single applicant, Overhead and nderground

Applicants must meet the following requirements when installing services.

- A. PG&E’s service conductors must be pulled into the enclosure and connected to the bypass-test facility’s line-termination lugs.
- B. One set (i.e., one conductor per phase) of load conductors must be routed and formed to allow PG&E to pull their service laterals without encountering any obstructions.
- C. For overhead service, applicants must provide and install service-entrance conductors from the weatherhead to the enclosure. Applicants must connect the conductors to the bypass-test facility’s line-termination lugs.
- D. The right side, test-bypass blocks (i.e., two poles) are identified as the power leg (i.e., high leg or stinger leg) for metering three-phase, -wire, delta service. The power leg is identified by using the color orange. Orange tape is typically used.
- E. All section covers can be removed independently however, after the meter is in place, the upper cover must not be removable. After the meter is in place, the lower cover must be sealable.
- F. For meter socket jaw requirements, see [Section](#) , [Subsection](#) .6., “[Meter Types and Connections](#),” on Page -26.
- G. Install range-taking lugs from 6 American wire gauge (A G) to 1/0 A G for services up to 12 amps, and 2 A G to 2 0 thousand circular miles (kcmil) for services rated from 126 amps through 200 amps.

.2. . (continued)

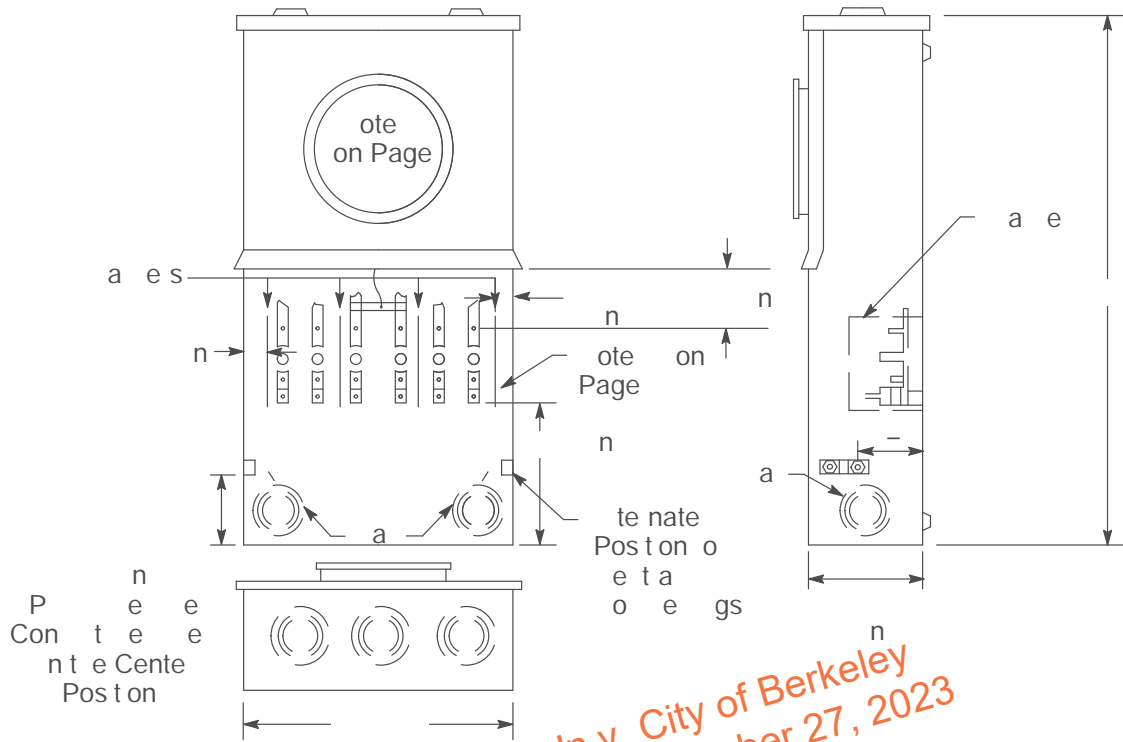


Figure 7-1  
 used, Safety-Socket Meter for Self-Contained Metering (0 mps-100 mps)

*cited in Cal. Rest. Ass'n v. City of Berkeley  
 No. 21-16278am filed December 27, 2023*

.2. . (continued)

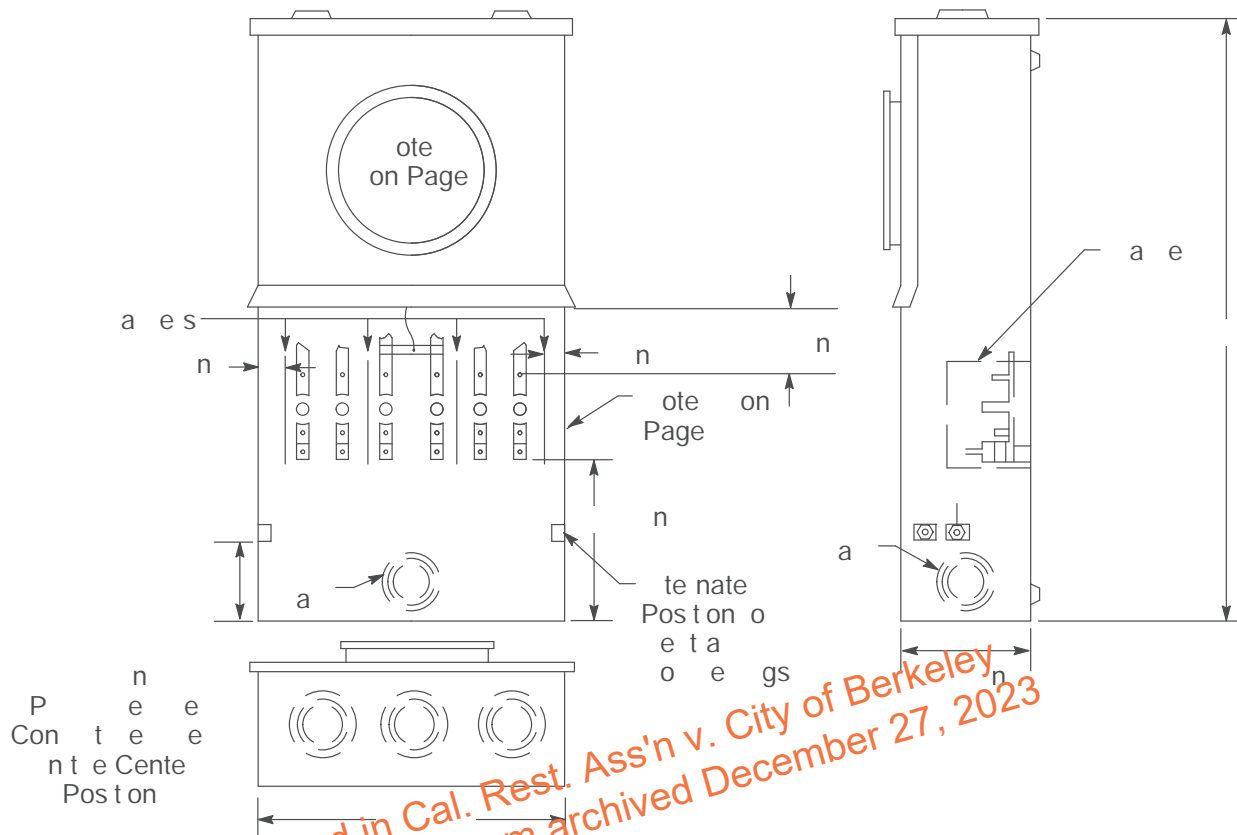


Figure 7-2 used, Safety-Socket Meter for Self-Contained Metering (101 mps–200 mps)

7.2 Services, Over 200 mps, Single Applicant, Underground

Applicants must meet the following requirements when installing services and equipment.

Services, 201 mps Through 400 mps, Three Phase, and 201 mps Through 400 mps, Single Phase

1. When planning a single, underground, single-phase or three-phase service, applicants must furnish, install, own, and maintain combination meter and current-transformer cabinets, as illustrated in Figure 7-2, "Underground Combination Meter and Current-Transformer Cabinet (201 Amps– 400 Amps, 1Ø or 3Ø)," on Page 7-3.

NOTE: See Section 9, "Electric Metering Components and Cable Terminating Facilities," for details about internal components.

2. The current transformer mounting base must include termination bolts, Belleville washers, and nuts on the line and load sides necessary to connect the current transformers and the PG&E service conductors to the line side.

.2.6. (continued)

- . Applicants must install a maximum of one set (i.e., one conductor per phase) of load conductors before PG&E installs the current-transformers.
- . The applicant's conductor must be terminated on the top (load side) of the current-transformer mounting base or termination enclosure busing.
- . The applicant's conduit and conductors leaving the cabinet must not be installed within 2 inches of any corner of the cabinet or within 2 inches of the PG&E service-entrance conduit location.
- 6. The applicant's load conductors must be routed and formed properly to allow PG&E to pull their service laterals without encountering any obstructions.
  - . The applicant's conductors must not cross in front of or behind the PG&E service entrance conduit and must not obstruct the PG&E current transformers or test switch areas.
- 8. Applicants must ensure that provisions are made for the underground service neutral when installing an insulated, bondable termination in the current-transformer cabinet.
- 9. Applicants must mark the power leg (i.e., high leg or stinger leg) of a 20/120-volt, three-phase, three-wire delta service by using the color orange. This is for metering purposes. Orange tape is typically used.
- 10. Applicants must ensure that cabinets meet the following requirements.
  - All panels and covers must be sealable and all securing screws must be captive.
  - Outdoor current transformer cabinets are weatherproof.
  - A neutral is bonded to the enclosure.
  - Current transformer cabinets are not used as splicing chambers and current transformers are not tapped off to supply other meters or used for other purposes.

.2.6. (continued)

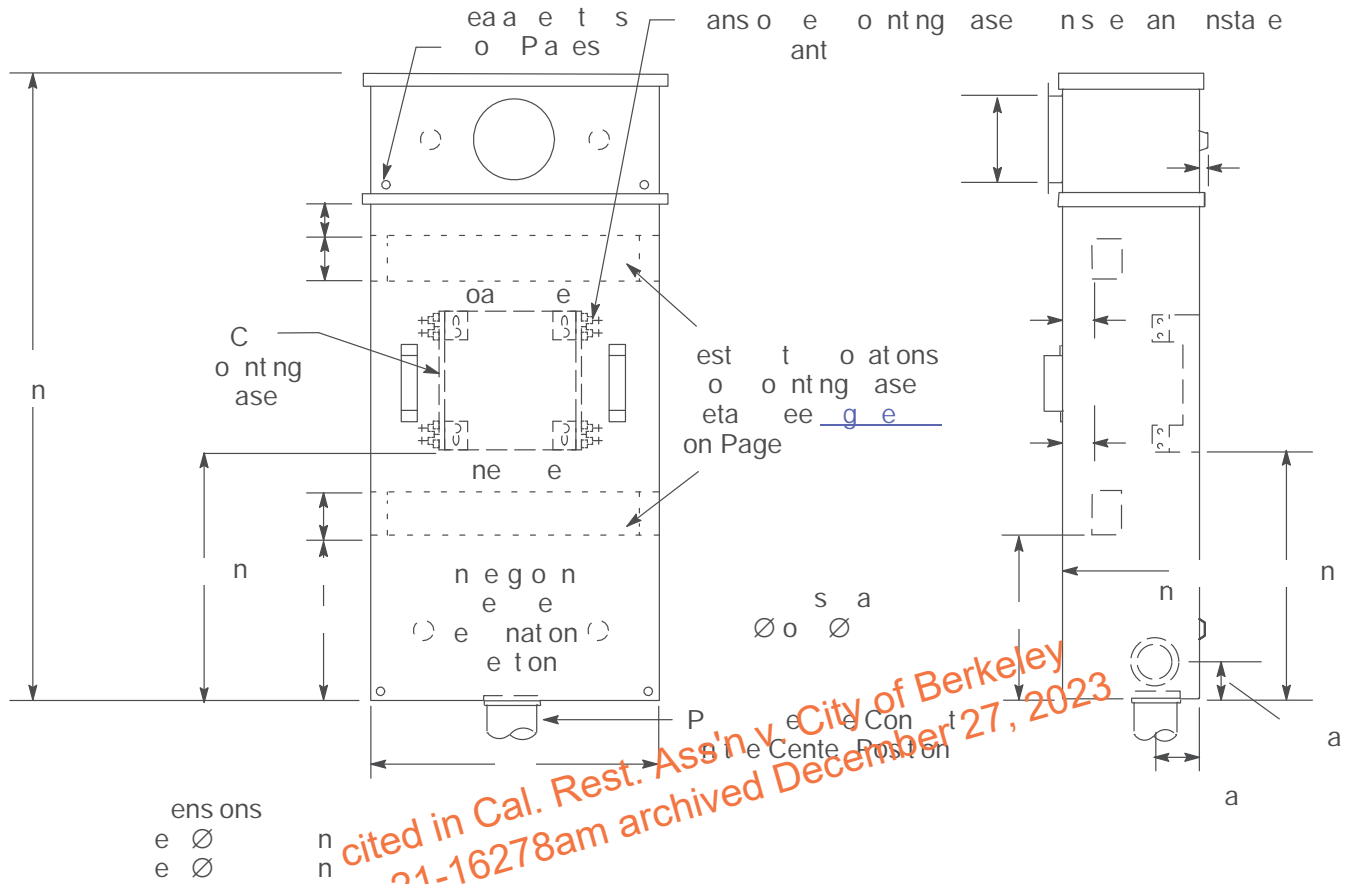


Figure 7-  
Underground Combination Meter and Current-Transformer Cabinet  
(201 mps– 00 mps, 1Ø or Ø)

Services, 201 mps Through 00 mps, Three Phase, and  
201 mps Through 00 mps, Single Phase,  
Current-Transformer Metering in used, Current-Transformer  
Cabinets

1. When applicants meter a single, underground service using current transformers, they must furnish, install, own, and maintain underground, service-termination pull boxes with separate, current-transformer cabinets and meter box, as illustrated in Figure - , “Separate-Based Current-Transformer Cabinet and Meter Box with Underground Service-Termination Pull Box (201 Amps– 00 Amps, Ø, and 201 Amps–600 Amps, 1Ø),” on Page -8.

NOTE: See [Section 9](#), for details about internal components.

.2.6. (continued)

2. Applicants must furnish and connect a maximum of one set (i.e., one conductor per phase) of service-entrance conductors to the line and load sides of the current-transformer mounting base and to the load side of the termination facilities in the underground, service-termination pull box. The applicants service-entrance conductors and load conductors must be installed before PG&E installs the current transformers.
  - . The current-transformer mounting bus bars must include termination bolts, Belleville washers, and nuts on the line and load sides necessary to connect the PG&E current transformers.
  - . PG&E pulls and terminates its service-entrance conductor directly to the applicant-furnished, service-termination facility in the underground service-termination pull box.
  - . The applicant installs one set (i.e., one conductor per phase) of service-entrance conductors that enter the current-transformer cabinet and terminate on the top (line side) of the current-transformer mounting bus bars.
6. The applicant must not install conduit within 2 inches of any corner of the cabinet.
  - . The applicant's conductor must be routed properly to ensure they do not cross in front of or behind the PG&E current transformer wires and do not obstruct the PG&E current transformer area.

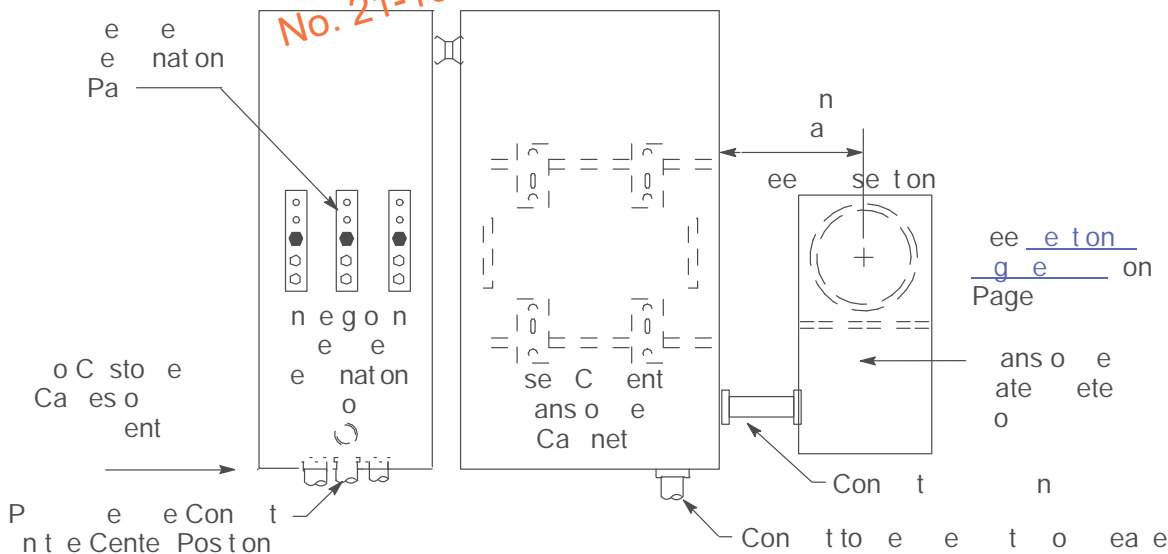


Figure 7-  
 Separate- used Current-Transformer Cabinet and Meter  
 with Underground Service-Termination Pull  
 (201 mps- 00 mps, Ø and 201 mps- 00 mps, 1Ø)

**.2.6. (continued)**

C Services, 00 mps Through 00 mps, Single Phase or Three Phase, Current-Transformer Metering in used, Current-Transformer Cabinets

1. When planning a single, underground, three-phase service, applicants must furnish, install, own, and maintain combination meter and current-transformer cabinets, as illustrated in Figure - , “ Underground Service Combination Meter and Current-Transformer Cabinet (600 Amps, 1 or , 800 Amps ),” on Page -10.

NOTE: The only PG E-approved manufacturer of the enclosure in figure 7-5 is Milban Manufacturing.

2. This enclosure is allowed in wall-mounted applications connected to an underground service. The enclosure must be installed so the bottom is between 6 inches to 9 inches above grade or above the working space area.

. The current transformer mounting base must be rated for the exact ampacity as the PG&E service and must include termination bolts, Belleville washers, and nuts on the line and load sides necessary to connect the current transformers and the PG&E service conductors to the line side.

. Applicants must install and connect no more than three load-side conductors per phase to the current transformer mounting base.

The applicant's conductor must be terminated only on the top (load side) of the current transformer mounting base.

6. The applicant's conduit and load conductors must be installed so they leave the enclosure (cabinet) either out of the top or exit out of the right or left side, no less than 12 inches from the top of the enclosure.

. The applicant's load conductors must be routed and formed correctly. The load conductors must not run downward to the middle or bottom of the enclosure, cross in front of or behind the PG&E service entrance conduit, or obstruct the PG&E current transformers or test switch areas.

8. Applicants must ensure that provisions are made for the underground service neutral when installing an insulated, bondable termination in the current transformer cabinet.

9. For metering purposes, applicants must mark the power leg (i.e., high leg or stinger leg) of a 2 0/120-volt, three-phase, -wire delta service by using the color orange. Orange tape is typically used.



.2.6. (continued)

10. Applicants must ensure enclosures meet the following requirements:

- All panels and covers must be sealable, and all securing screws must be captive.
- Outdoor current transformer cabinets are weatherproof.
- A neutral is bonded to the enclosure.
- Current transformer cabinets must not be used as conductor splicing chambers and do not tap off conductors from the current transformer's or it's mounting base to supply other meters.

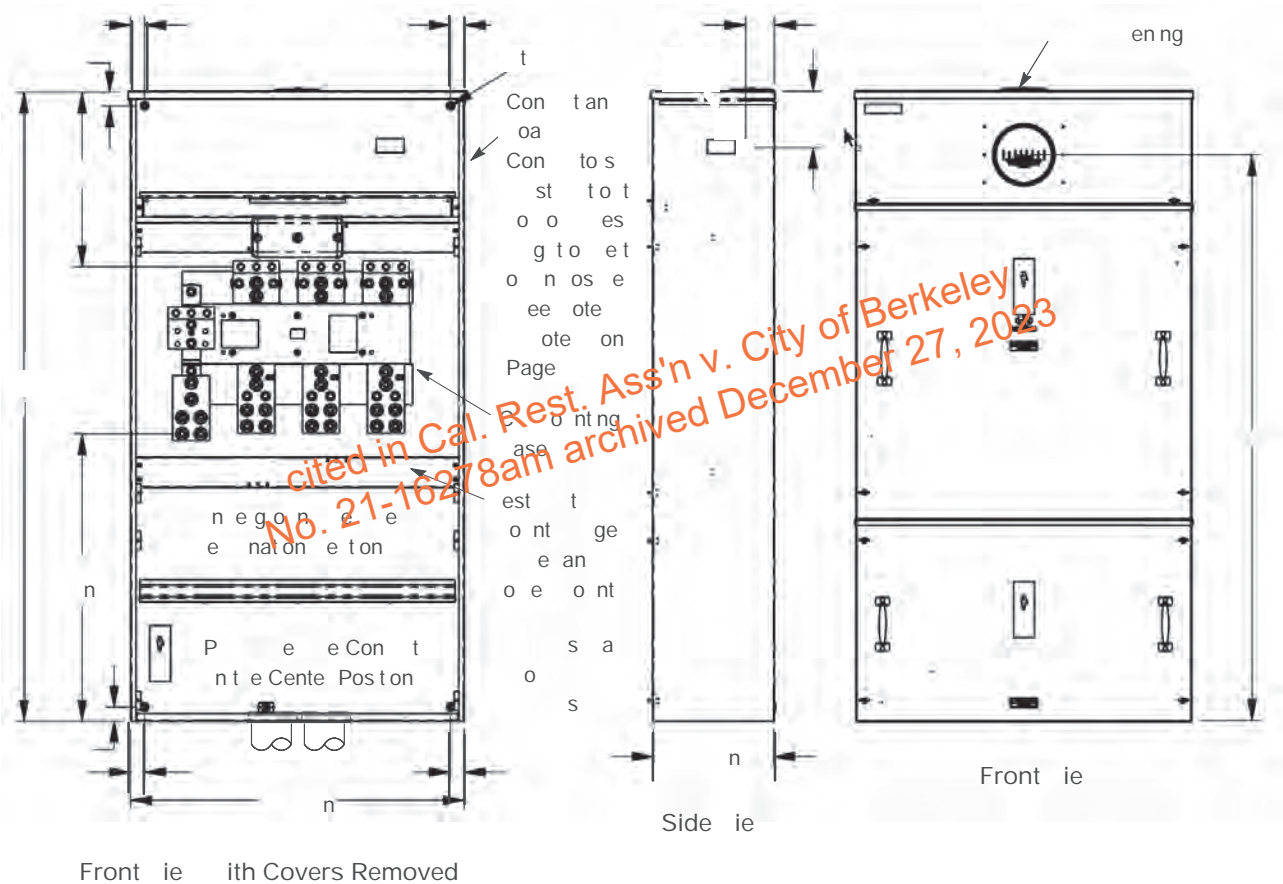


Figure 7-  
Underground Service Combination Meter and Current-Transformer Cabinet  
(00 mps, 1 or , 00 mps )

notes in reference to Figure - .

1. The only PG&E-approved manufacturer of this specific enclosure is Milbank Manufacturing.
2. This enclosure must be installed so the bottom is between 6 inches to 9 inches above grade or above the working space area.

.2.6. (continued)

D Services, 201 mps and bove, Current-Transformer Metering in S itchboard Service Sections

1. hen applicants meter a single underground service using current transformers, they must furnish, install, own, and maintain a switchboard service section and facilities for terminating underground service conductors.
  2. Figure -6, Figure - , and Figure -8, below, illustrate typical arrangements of the switchboard service sections that are used in conjunction with a pull section or pull box for underground service-conductor termination.
- . PG&E pulls and terminates its service conductors directly to the applicant-furnished service-termination facilities in the underground service-termination pull section, pull box, or service section.

NOTE: See [Section 10, "Electric Switchboards: 0 olts Through 600 olts,"](#) for details.

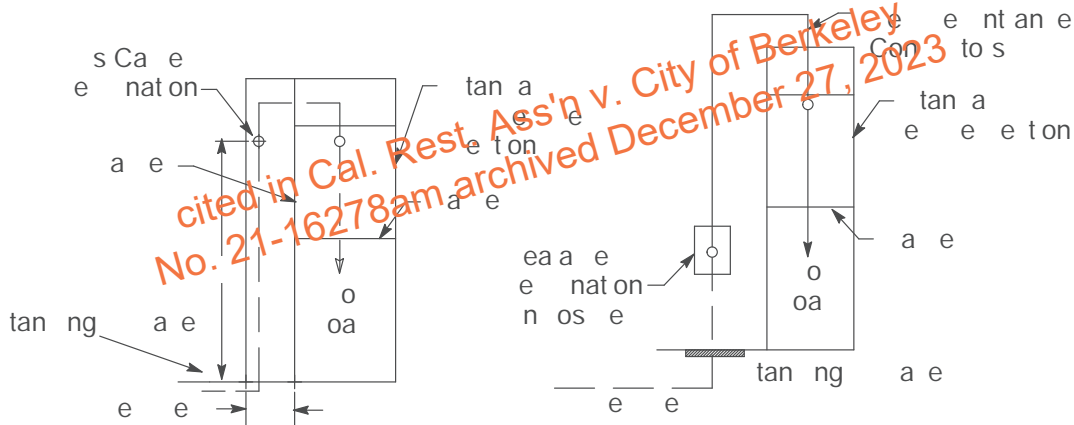


Figure 7-6  
S itchboard Pull Section

Figure 7-7  
Separate Pull o

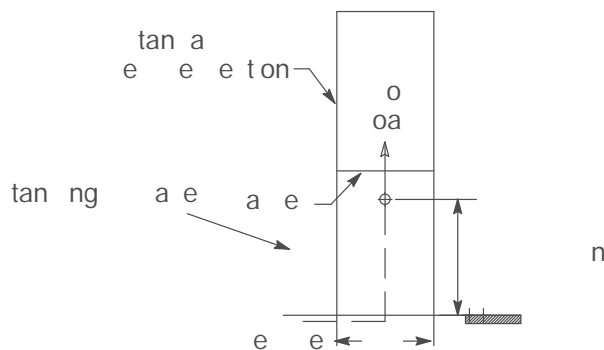


Figure 7-8  
ottom-Fed Service Section

## 7 2 7 Services, Over 200 mps, Single plicant, Overhead

Applicants must meet the following requirements when installing single-applicant, overhead services that are over 200 amps.

For all agricultural overhead services, install a cable protector around the service-entrance conductors entering the wall-mounted or panelboard-mounted meter panel. Order using either Material Code 820 or Material Code 820 , found in [umbered Document 062288](#), “[nderground Conduits,” Table 1](#) , on Page 8 (in [Appendix C, “Electric and Gas Engineering Documents”](#)).

## Services, 201 mps Through 00 mps, Single Phase or Three Phase ith Current Transformers

1. hen installing a single, overhead, single-phase or three-phase service, applicants must furnish, install, own, and maintain combination meter and current-transformer cabinets, as illustrated in Figure -9, “Overhead-Fed Combination Meter and Current-Transformer Cabinet, (201 Amps– 00 Amps, 1Ø or Ø),” shown on Page -1 . See [Section 9](#) for details about internal components.
2. Applicants must install one set (i.e., one conductor per phase) of service-entrance conductors before PG&E installs the current-transformers. Also applicants must connect the service entrance conductors to the line and load sides of the current-transformer mounting base.
  - . The current-transformer mounting base must include termination bolts, Bellevue washers, and nuts on the line and load sides necessary to connect the current transformers. See [Section 9](#) for details about these internal components.
  - . The applicant’s service entrance conductor must be terminated on the top (load side) of the current-transformer mounting base or termination enclosure busing.
  - . The applicant’s load conductor must be terminated on the bottom (load side) of the current-transformer mounting base.
6. The applicant’s conduit must not be installed within 2 inches of any corner of the cabinet.
  - . The applicant’s conductors must be routed and formed properly to ensure they do not obstruct the PGE current transformer and test switch areas.
8. Applicants must ensure that cabinets meet the following requirements.
  - All panels and covers must be sealable and all securing screws must be captive.
  - Outdoor CT cabinets are weatherproof.
  - A neutral is bonded to the enclosure.
  - CT cabinets are not used as splicing chambers and CTs are not tapped off to supply other meters or used for any other purposes.

.2. . (continued)

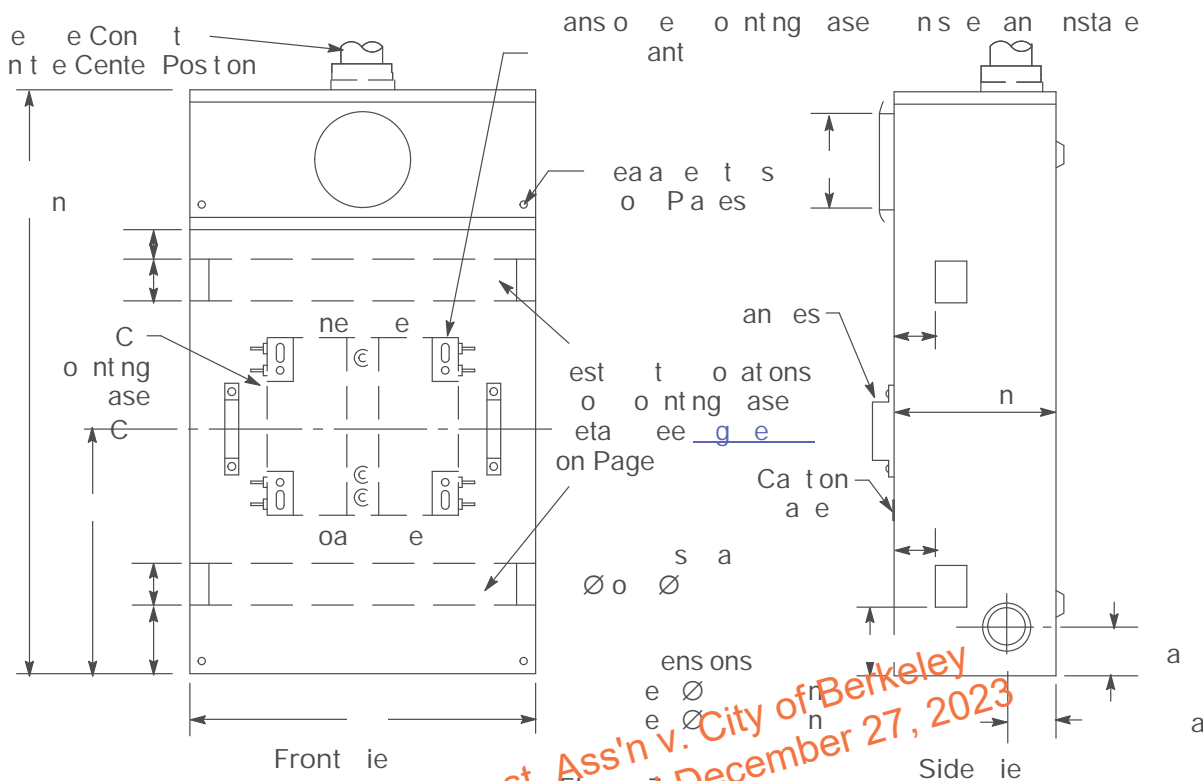


Figure -10  
Overhead-Fed Combination Meter and Current-Transformer Cabinet,  
(201 mps- 00 mps, 1Ø or Ø)

Services, 201 mps Through 00 mps, Single Phase or Three Phase, with Current-Transformer Metering

- When installing a single, overhead, single-phase or three-phase service using current transformers, applicants must furnish, install, and maintain separate current-transformer cabinets and meter boxes, as illustrated in Figure -10, "Overhead-Fed, Separate-Bused, Current-Transformer Cabinet and Safety-Socket Meter Box (201 Amps- 00 Amps, 1Ø or Ø)," on Page -1 . Also required are service-entrance conductors, conduit, and weatherhead to the point of attachment to PG&E's overhead service.

NOTE: See [Section 9](#), for details about internal components.

- Applicants must install one set (i.e., one conductor per phase) of line-side conductors and one set of load-side conductors before PG&E installs the current transformers. Connect the service-entrance conductors to the line side of the current-transformer mounting bus bars and load the conductors to the load side of the current-transformer mounting bus bars.

.2. . (continued)

- . The current transformer bus bars must include termination bolts, Belleville washers, and nuts on the line and load sides necessary to connect the current transformers. See [Section 9](#), for details about these internal components.
- . The applicant’s conduit must not be installed within 2 inches of any corner of the cabinet.
- . The applicant’s conductors entering and exiting the cabinet must be formed and routed properly to ensure they do not obstruct the PG&E current transformer area.

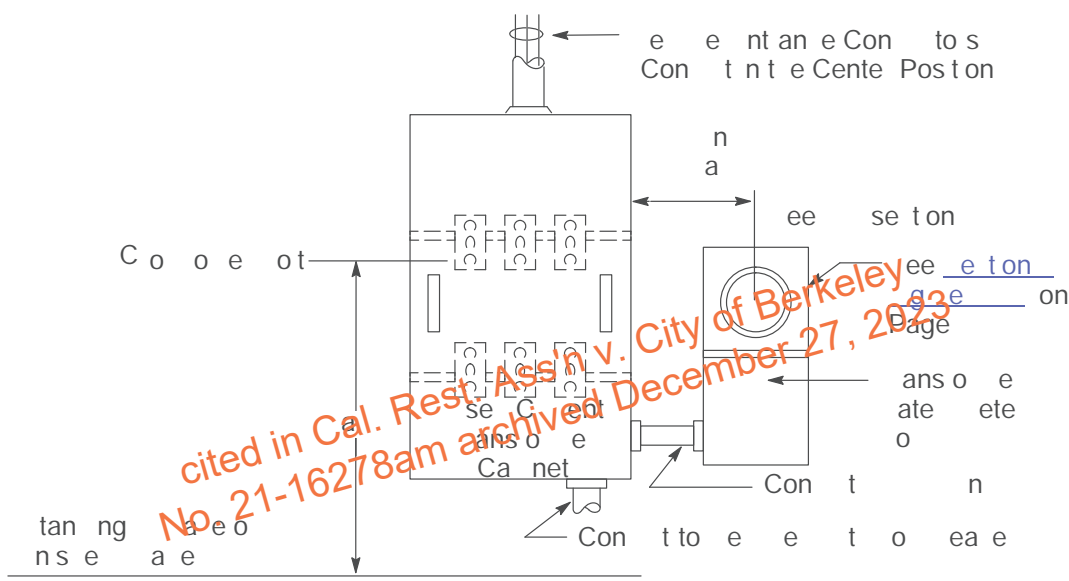


Figure 7-10  
Overhead-Fed, Separate-Used, Current-Transformer Cabinet and Safety-Socket Meter (201 mps-00 mps, 1Ø or Ø)

C Services, 201 mps and above, Current-Transformer Metering in Switchboard Service Sections

1. When installing a single, overhead service using current transformers, applicants must furnish, install, own, and maintain a switchboard service section with provisions for the overhead service termination.
2. Typical switchboard service-section arrangements are illustrated in Figure -11, “Overhead, Service-Termination, Standard Switchboard Service Section (0 volts-600 volts),” on Page -1 .

NOTE: See [Section 10, “Electric Switchboards: 0 volts Through 600 volts.”](#) for details.

.2. . (continued)

- . Applicants must furnish and install service-entrance conductors and either cable or bus bars, as described below.
  - When switchboards are served through bus-bar conductors, the conductors must enter through the top or at the side or back in the upper 10-inch section.
  - When switchboards are served through cable conductors, the conductors must enter through the top of the switchboard. Figure 7-11, on Page 7-1, illustrates an extension that allows for horizontally incoming conduits from the side or rear of the standard switchboard service section.
- . Applicants must ensure that the service-entrance conductors feed from top to bottom. Load conductors must leave below the metering compartment barrier. Applicants must ensure that service entrance conductors are connected to the busing in the service sections with lugs approved for the type of conductors used.

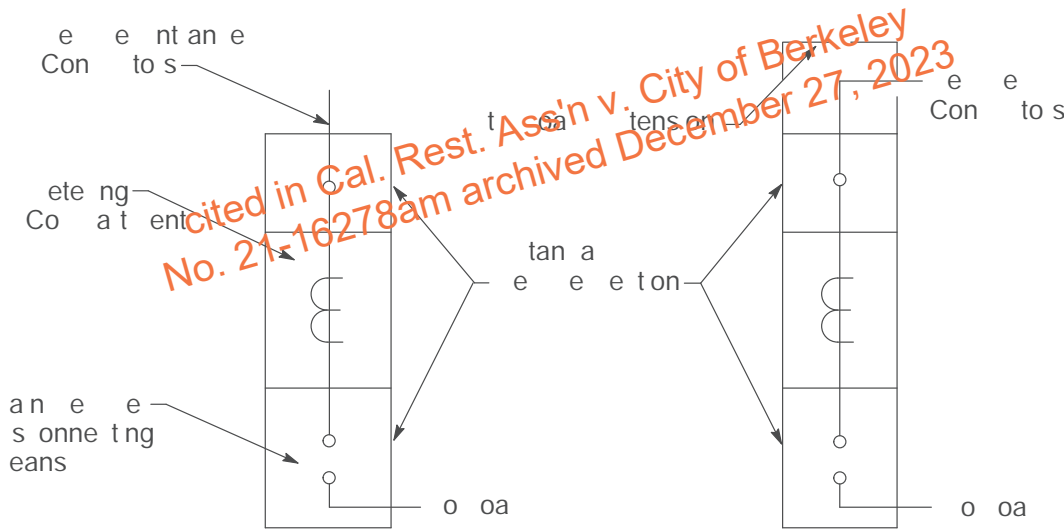


Figure 7-11  
Overhead, Service-Termination, Standard Switchboard Service Section  
(0 volts- 00 volts)

7.2 Multi-Applicant Meter Installations

Applicants must meet the following requirements when installing multi-applicant meters.

- A. Applicants must install grouped meters for multi-applicant buildings where each occupant is metered individually.
- B. Each unit of a multi-applicant installation must be considered a single applicant and must meet the metering requirements described in Subsection 7.2.1, “Services, 0 Amps Through 200 Amps, Single Applicant, Overhead and Underground,” on Page 7-1.

## .2.8. (continued)

- C. Applicants must ensure that service entrance conductors for multi-applicant installations extend from PG&E's service termination point to the line side of the meter socket jaw of each socket.
- D. Applicants must ensure that the minimum centerline spacings between meter sockets are 1-1/2 inches horizontal and 8-1/2 inches vertical.

NOTE: PG&E provides and installs nonconductive, meter-socket, blank-off covers before energizing meter panels with vacant meter sockets. PG&E will not energize meter panels and sockets unless blank-off meter covers are installed and sealed. See [Section 6, "Electric Metering: Residential," Subsection 6.2. ., "Electric Meter Socket Covers and Seals,"](#) on Page 6-2., for material codes and further information.

- E. For multimeter installations, PG&E determines the ampacity rating of a grouped multimeter installation using one of the following two methods.
  1. For installations without a main switch or breaker, the service rating will be the rating of the electrical enclosure or service-termination section, pull can, or other service-termination enclosure where PG&E terminates and connects its supply facilities and conductors. Also, see [Section 1, "General," Subsection 1.1.B.,](#) on Page 1-1 .
  2. For installations with a main switch or breaker, the rating of the service to be supplied is the rating of the termination section, pull can service section, or main service switch continuous current rating (typically whichever is greater). Also, see [Section 1, Subsection 1.1 .A.,](#) on Page 1-1 .
- F. When a sealable gutter protrudes beyond the meter-mounting surface by more than 1/2 inches, applicants must maintain 10 inches of clearance from the centerline of the meter face. Otherwise, applicants must have a minimum 1-1/2 inches of vertical clearance.

.2.8. (continued)

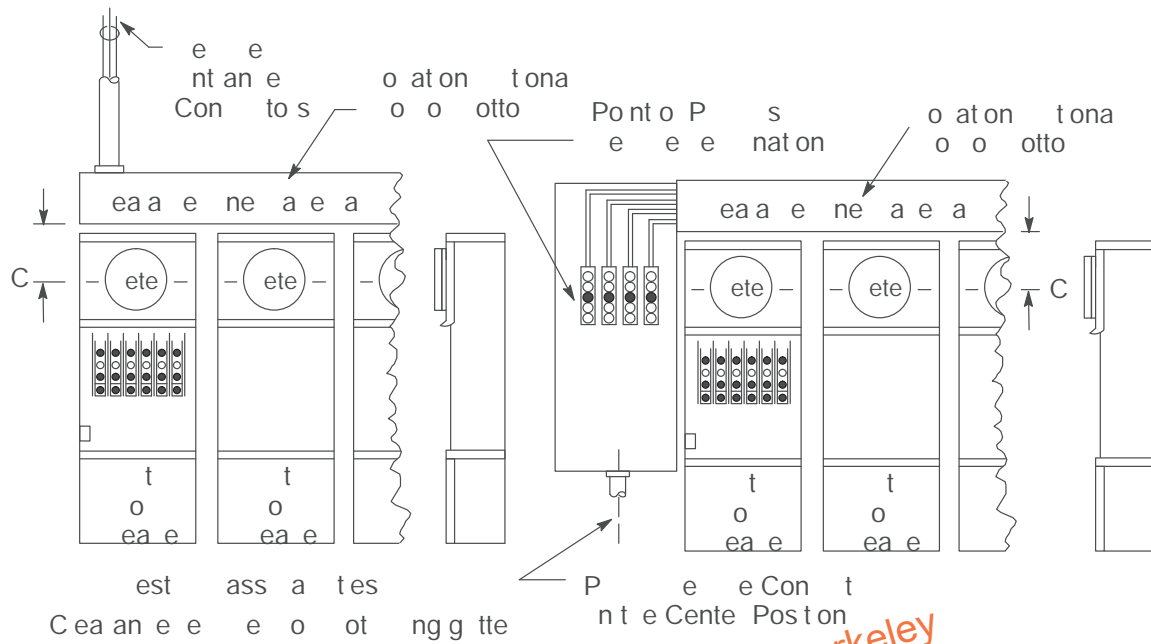


Figure 7-12 Overhead Service, Grouped-Meter Installation with a Main Switch (Maximum 100 mps, 1Ø or 1Ø)

Figure 7-1 Underground Service, Grouped-Meter Installation with a Main Switch (Maximum 100 mps, Ø, or 100 mps, 1Ø)

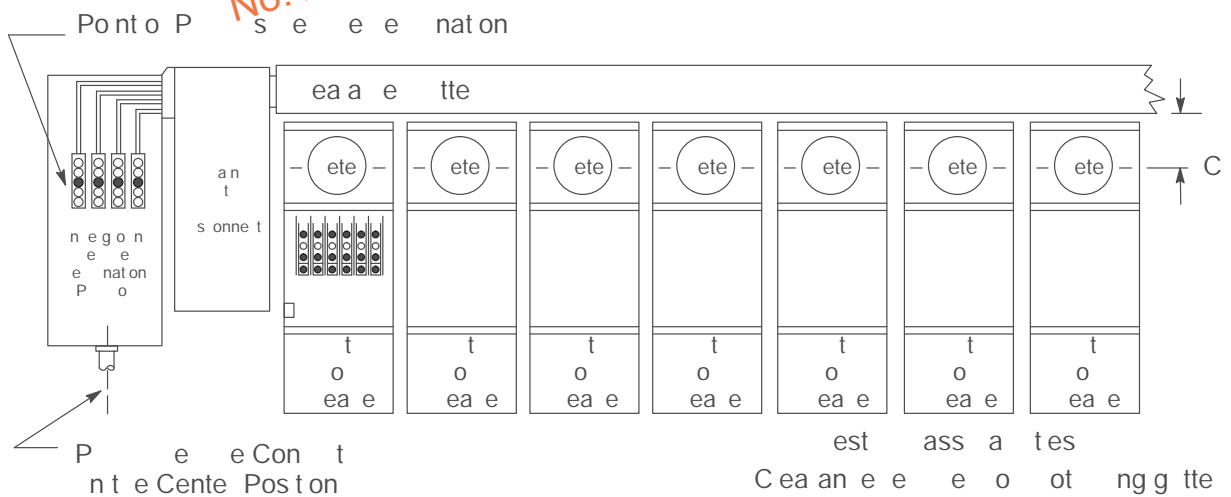


Figure 7-1 Grouped-Meter Installation with a Main Switch (Maximum 100 mps, Ø, or 100 mps, 1Ø)



This Page Intentionally left Blank

*cited in Cal. Rest. Ass'n v. City of Berkeley  
No. 21-16278am archived December 27, 2023*

SECTION  
ELECTRIC METERING:  
PEDESTALS

*cited in Cal. Rest. Ass'n v. City of Berkeley  
No. 21-16278am archived December 27, 2023*

SECTION ELECTRIC METERING: PEDESTALS

SECTION ELECTRIC METERING: PEDEST S

*cited in Cal. Rest. Ass'n v. City of Berkeley  
No. 21-16278am archived December 27, 2023*

## Section Electric Metering: Pedestals

---

### 1 Scope

This new section provides the design and installation requirements for electric metering pedestals in the PG&E service territories. Only the PG&E approved metering pedestals described in this section can be installed.

NOTE: This section was previously titled “Electric Metering: Direct Access.” If you have questions regarding direct access, refer to [Electric Rule 22, “Direct Access,”](#) and PG&E’s [Direct Access Standards for Metering and Meter Data \(D SMMMD\) in California](#), March 1999 revision (only members can access this information online).

### 2 Residential Electric Metering Pedestals

Residential electric meter pedestals, as shown in Figure 8-1, “Residential Electric Metering Pedestal,” on Page 8-2, must have a minimum rating of 100 amps and a maximum rating of 200 amps. The pedestal also must meet the requirements specified in the [Electric Utility Service Equipment Requirements Committee \(EUSERC\)](#) manual, Drawing 0 .

For authorization to attach telephone and cable television terminating facilities to the post, contact your local PG&E project coordinators.

*cited in Cal. Res. Ass'n v. City of Berkeley  
No. 21-16278am archived December 27, 2023*

Section 8, Electric Metering: Pedestals

8.2. (continued)

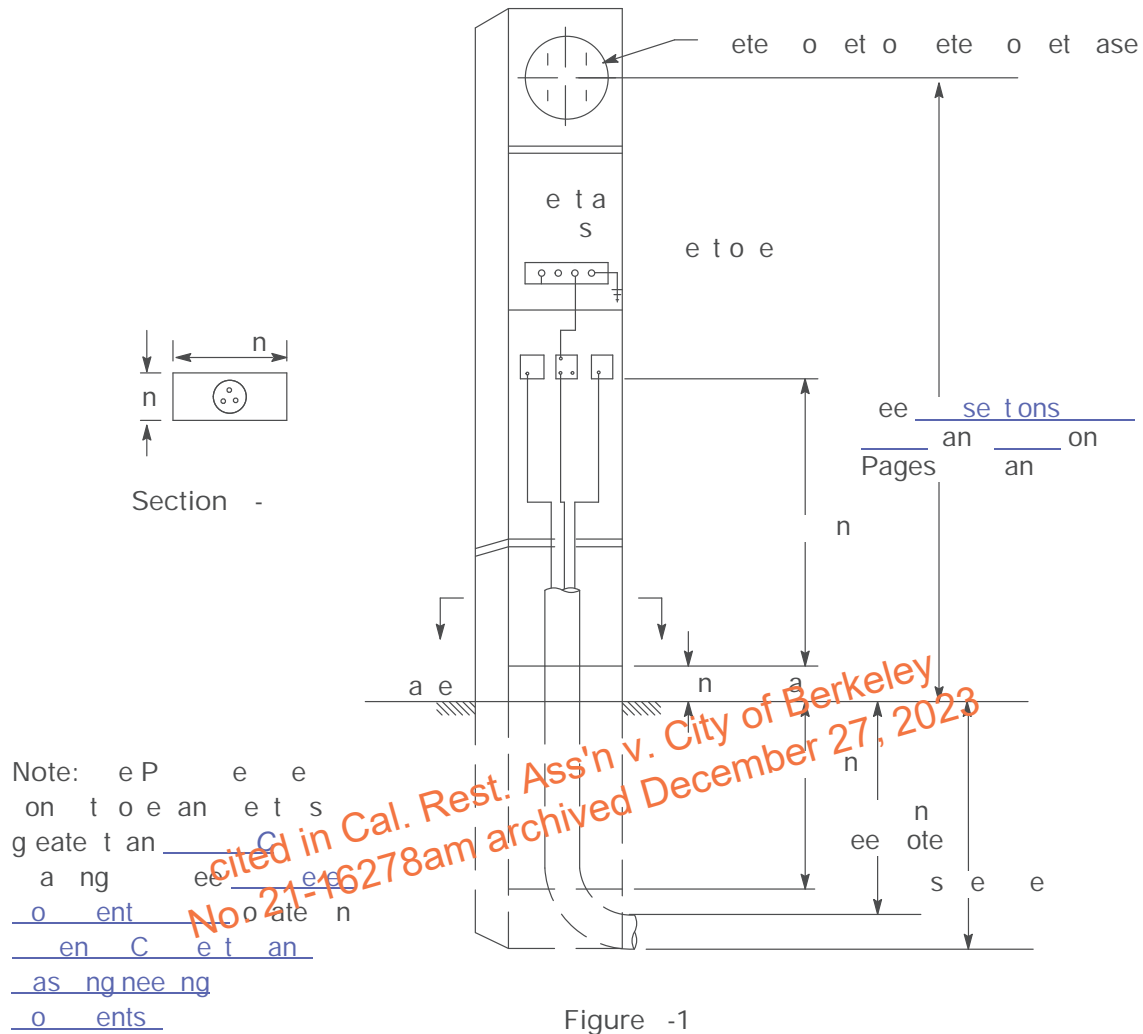


Figure -1 Residential Electric Metering Pedestal

Nonresidential Single-Meter Service Pedestals, 100 200 mps

Applicants must ensure that nonresidential service pedestals meet the following requirements.

- A. Exterior Hood: An enclosing cover that is hinged to allow the front, sides, and top of the hood to rotate upward and back, 90 degrees or more, as one unit to expose the internal metering compartment.
  - 1. Ensure that the lifting force required to open the hood does not exceed 2 pounds.
  - 2. Also, the hood must have a locking device to prevent it from closing while in the open position.

8. . (continued)

- B. Metering Compartment: The meter socket must be mounted on a support, attached to the meter panel, and provided with a sealing ring. Enclose the metering compartment with an enclosing cover (i.e., exterior hood) that meets the following requirements.
1. Ensure the area in front of the meter sockets and test bypass is not blocked with side panels, enclosure walls, or other obstruction as described in 8. .A., "Exterior hood," on Page 8-2. This provides additional safety for personnel in the event of an arc flash.
  2. Equipped with a lifting handle.
    - . Sealable and lockable with a padlock having a 1/16-inch lock shaft.
    - . Provided with a fixed poly-carbonate viewing window.
- C. The test-bypass compartment cover:
1. Must be sealable and fitted with a lifting handle.
  2. as two lifting handles if the cover is more than 16 inches wide.
- D. Test-bypass blocks with rigid barriers are furnished, installed, and wired or bused to the meter socket by the manufacturer. Connection sequences must be line-loaded from left to right and clearly identified by block letter labeling at least 1/2 inch high.
- Applicants must ensure that test-bypass facilities are installed with the following clearances.
1. Facilities require 2 inches of vertical clearance from the upper test connector stud to the upper compartment access opening.
  2. Facilities require 2 inches from the center of the cable terminal screw to the lower compartment access opening.
    - . Facilities require 1-1/2 inches of side clearance from the rigid insulating barriers to the compartment sides and 1 inch to the compartment access openings.
- E. Utility compartment covers (i.e., exterior hood and pull section) are sealable and lockable using a padlock with a 1/16-inch lock shaft.
- F. Secure internal equipment (attached to the outer walls of the enclosure) in place with devices that cannot be loosened from the outside. Do not use screws or bolts requiring special tools for installation or removal.

## 8. . (continued)

## G. The terminating pull-section of the pedestals:

1. Comply with the minimum dimensions illustrated in Table 8-1, "Minimum Dimensions: Inches," on Page 8- .
2. Accept a minimum -inch conduit.
  - . ave covers equipped with lifting handles.
  - . Are equipped with aluminum-bodied mechanical lugs, ranging from #6 AWG through 250 kcmil, for terminating the service conductors.
  - . ave insulated cables or busses installed between the termination lugs and the test-bypass facilities.
6. ave protective metallic barriers, 16-gauge minimum, provided between the pull sections and their (the applicants') distribution sections.
  - . ave a 1/ -inch minimum clearance between the applicants' section walls and the barriers to prevent screws and bolts from protruding into the pull sections.

For information on structural-mounting requirements and pedestal support, consult your local PG&E project coordinator and meter shop.

*cited in Cal. Rest. Ass'n v. City of Berkeley  
No. 21-16278am archived December 27, 2023*

8. . (continued)

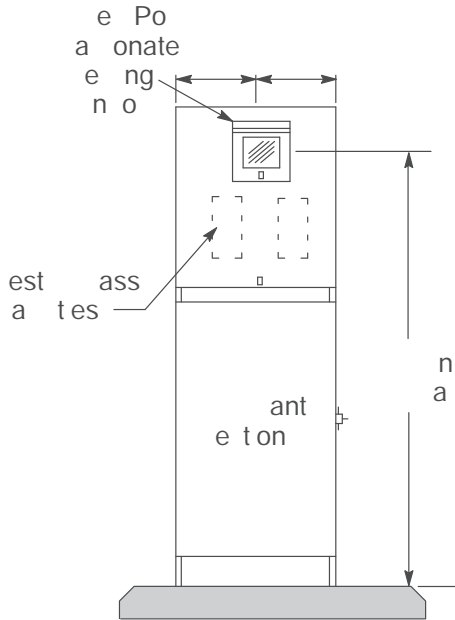


Figure -2  
Front View

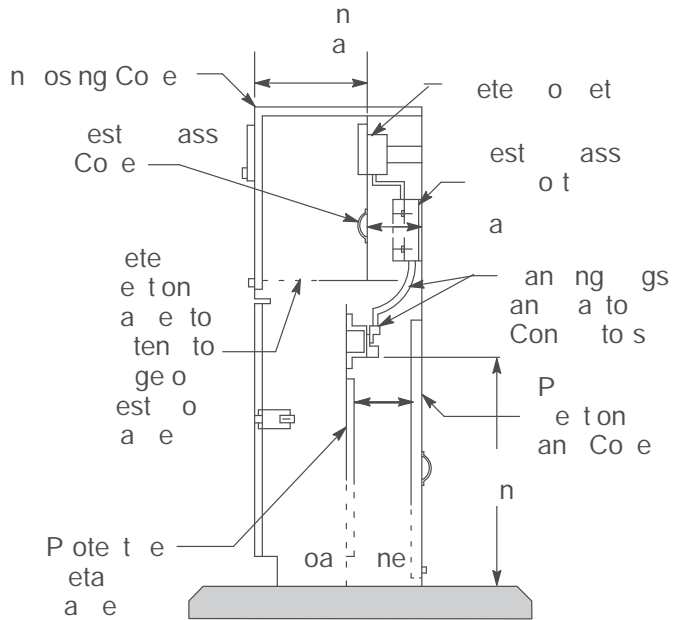


Figure -  
Side View

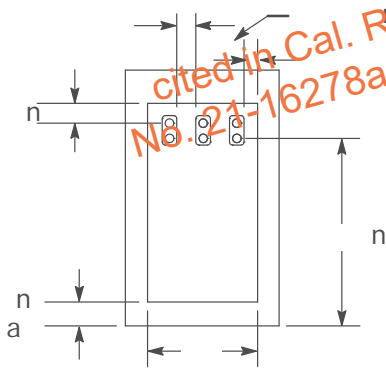


Figure -  
Service Cable Termination Section

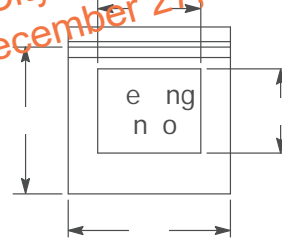


Figure -  
Filled Polycarbonate Window

Table -1 Minimum Dimensions (Inches)<sup>1</sup>

Service			D
ng e P ase			
ee P ase			

esto g es n e ton

Note: ese g es e esent gene esgn on g atons os tote esgns o ee an a oa onta t o oa oet oo nato e oet oo nato ons t t P s eet stan a san eet ete ng eat ents

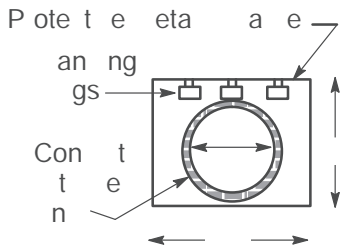


Figure -  
Service Cable Termination Section Top View



### 8.4. Nonresidential Dual-Meter Service Pedestals, 100–400 Amps

This subsection provides information on nonresidential dual-meter pedestals, either single phase or three phase, rated between 100 amps or 400 amps. These pedestals have two self-contained meter sockets, each rated for up to a maximum of 200 amps. The cable termination (i.e., pull section) may be located on the back or side of the pedestals. Applicants must ensure that nonresidential service pedestals meet the requirements shown in the figure below.

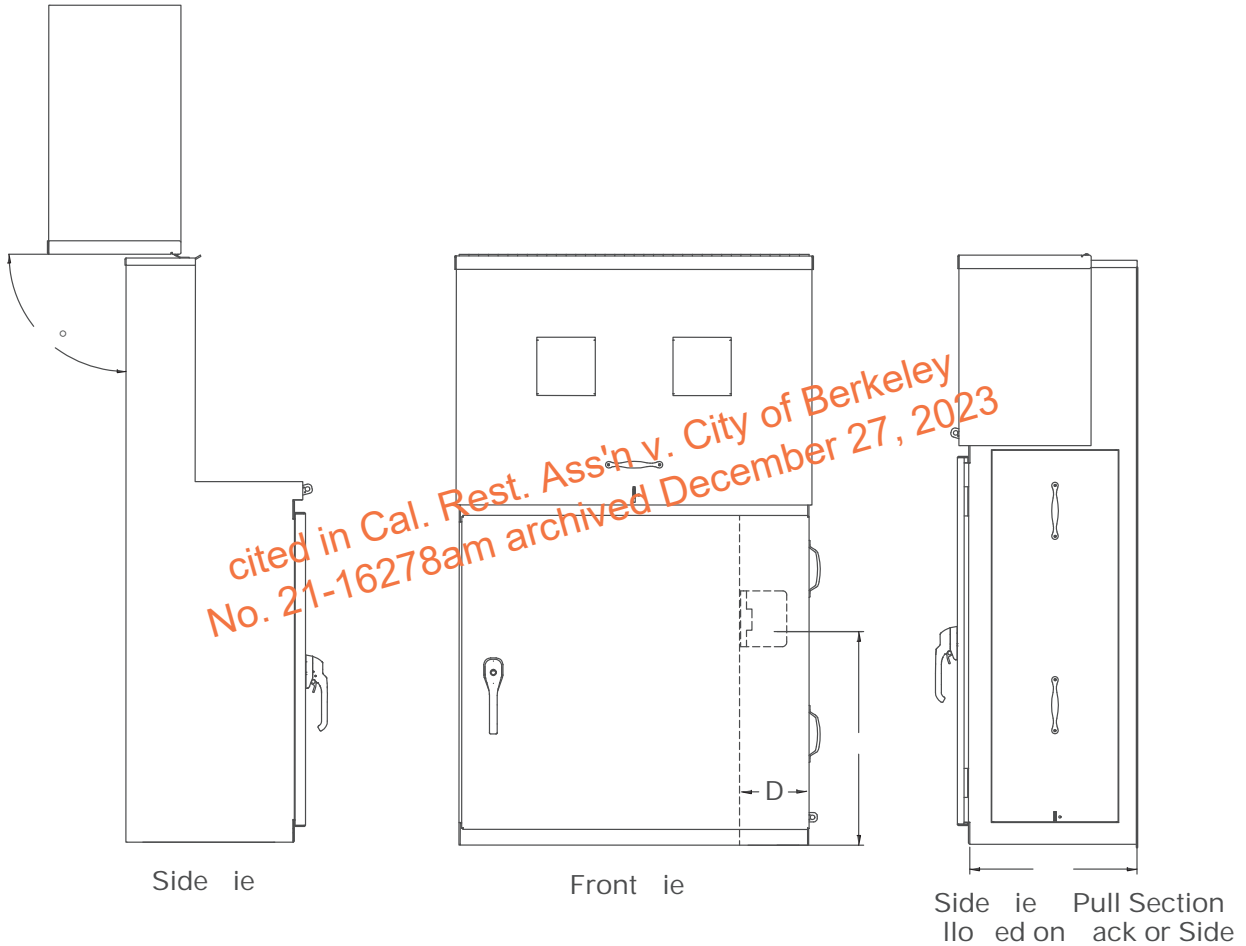


Figure -7  
Directional Views

8. . (continued)

Table -2 Minimum Dimensions (Inches)<sup>1</sup>

Service			C	D	E	
ng e P ase						
ee P ase						

es to g es n e ton

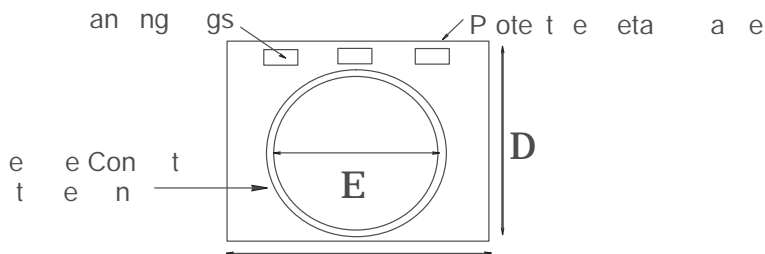


Figure -  
 Service Cable Termination Section Top View

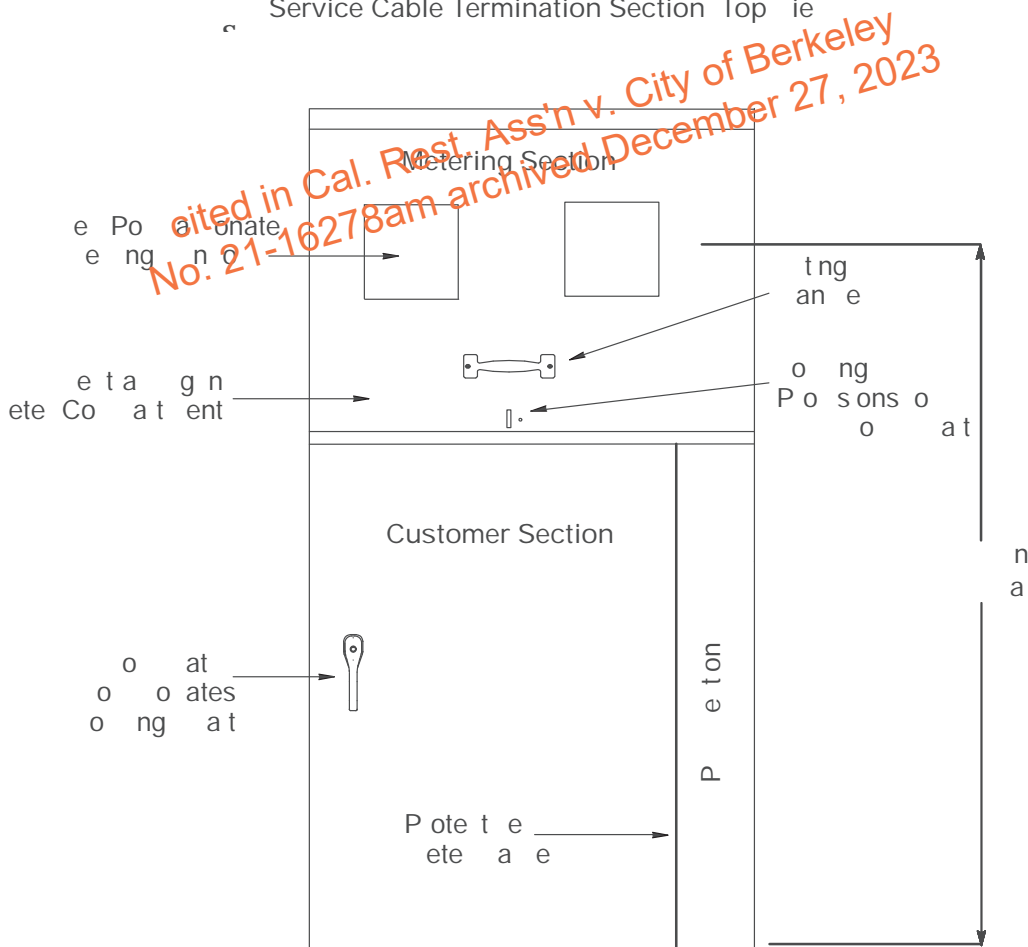
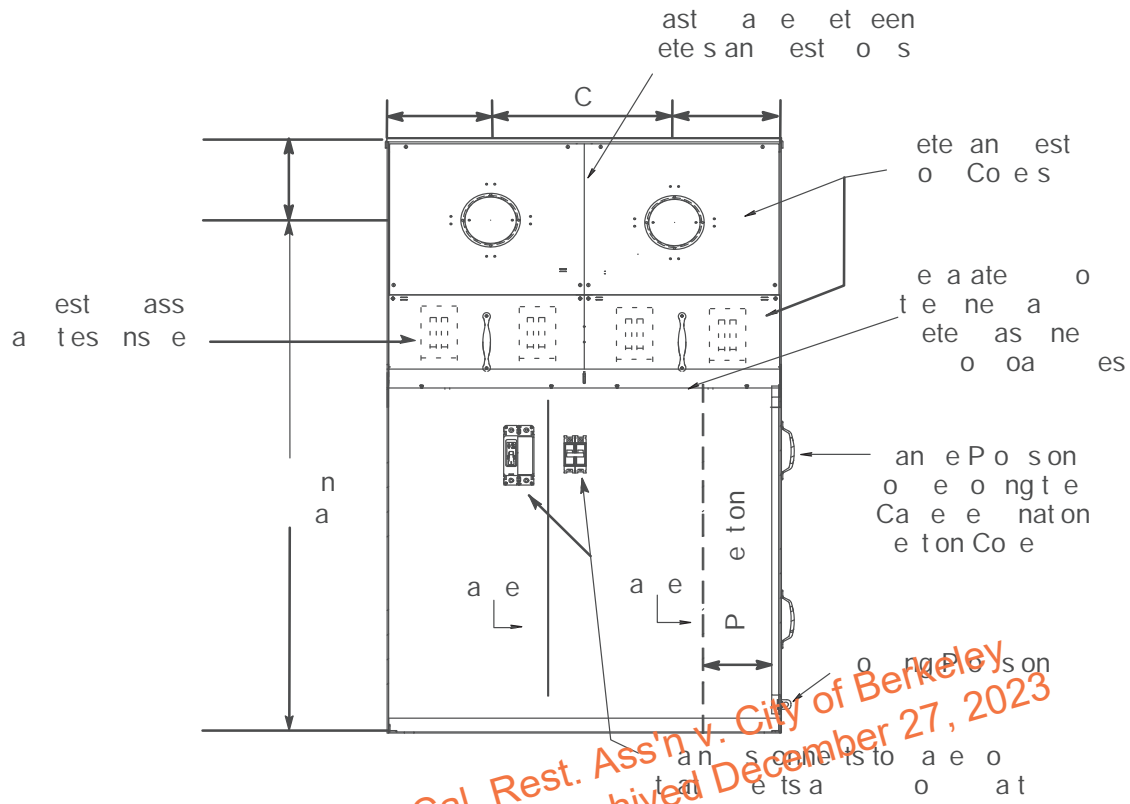


Figure -  
 Front Outside

Section 8, Electric Metering: Pedestals

8. . (continued)



*cited in Cal. Rest. Ass'n v. City of Berkeley  
 No. 21-16278am archived December 27, 2023*

Figure -10  
Front Inside

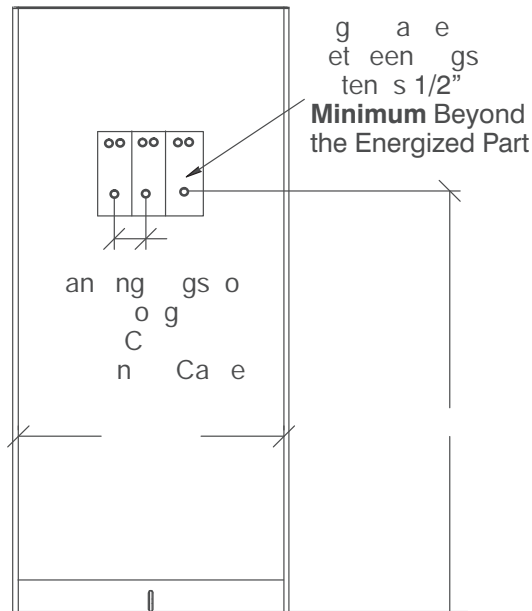
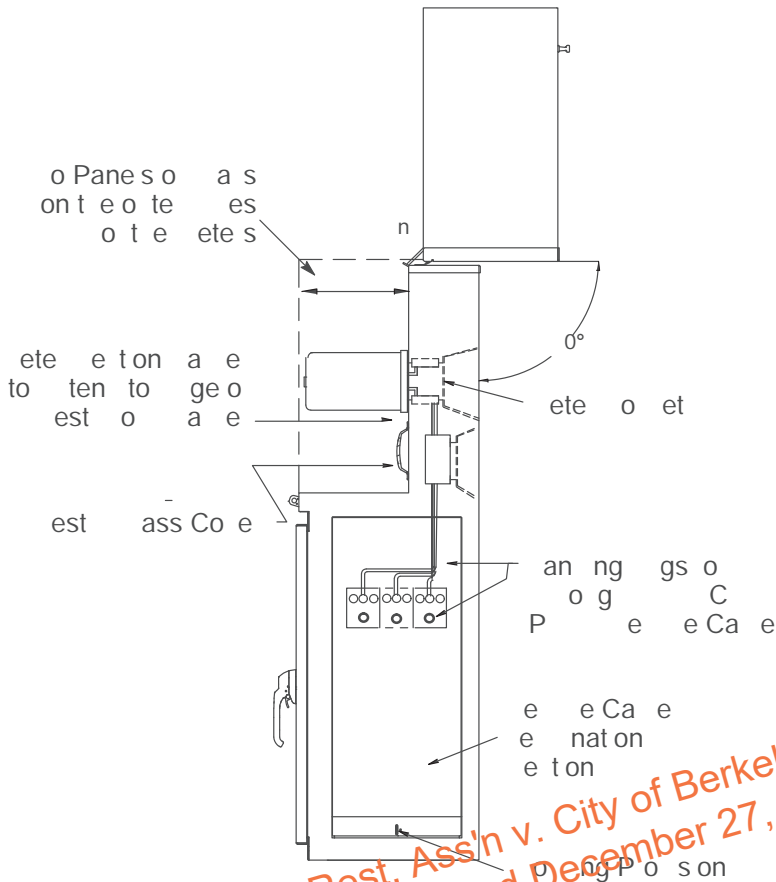


Figure -11  
PG&E Service Cable Termination (Pull) Section



*cited in Cal. Rest. Ass'n v. City of Berkeley  
 No. 21-16278am archived December 27, 2023*

Figure -1  
 Side view - Cover Removed

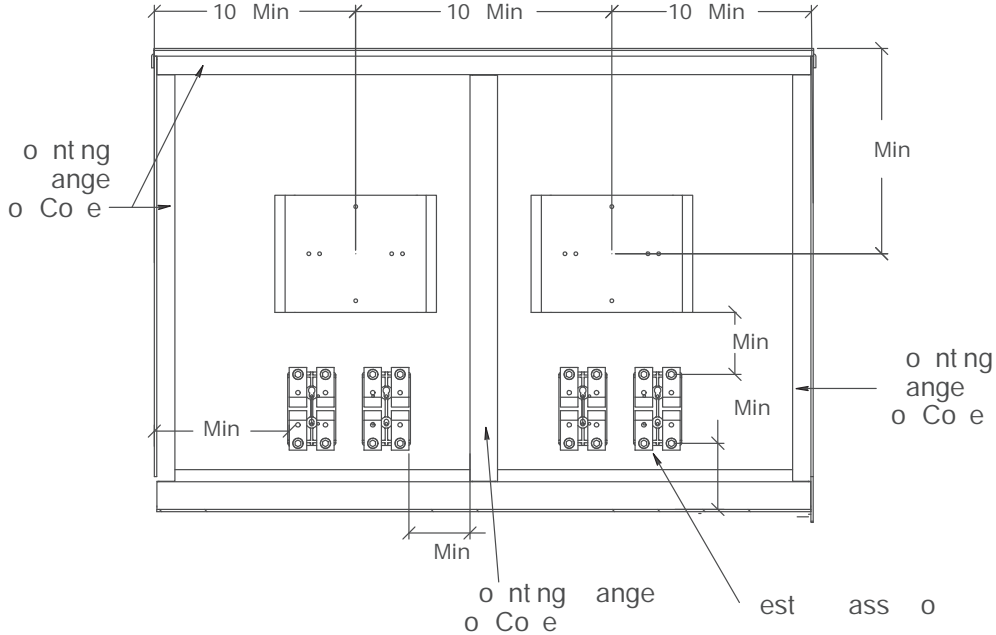


Figure -1  
 Front view -Interior Cover Removed

## 8. . (continued)

Applicants must ensure that nonresidential service pedestals meet the following requirements.

- A. **Exterior Hood:** An enclosing cover that is hinged to allow the front, sides, and top of the hood to rotate upward and back, 90 degrees or more, as one unit to expose the internal metering compartment.
1. Ensure that the lifting force required to open the hood does not exceed 2 pounds.
  2. Also, the hood must have a locking device to prevent it from closing while in the open position.
- B. **Metering Compartment:** The meter socket must be mounted on a support, attached to the meter panel, and provided with a sealing ring. Enclose the metering compartment with an enclosing cover (i.e., exterior hood) that meets the following requirements.
1. Ensure the area in front of the meter sockets and test bypass is not blocked with side panels, enclosure walls, or other obstruction as described in 8. .A., "Exterior Hood," above. This provides additional safety for personnel in the event of an arc flash.
  2. Equipped with a lifting handle.
    - . Sealable and lockable with a padlock having a 1/2-inch lock shaft.
    - . Provided with a fixed poly-carbonate viewing window.
- C. **The test-bypass compartment cover:**
1. Must be sealable and fitted with a lifting handle.
  2. as two lifting handles if the cover is more than 16 inches wide.
- D. **Test-bypass blocks with rigid barriers** are furnished, installed, and wired or bused to the meter socket by the manufacturer. Connection sequences must be line-loaded from left to right and clearly identified by block-letter labeling at least 1/2-inch high.

Applicants must ensure that test-bypass facilities are installed with the following clearances.

1. Facilities require 2 inches of vertical clearance from the upper test connector stud to the upper compartment access opening.
2. Facilities require 2 inches from the center of the cable terminal screw to the lower compartment access opening.
  - . Facilities require 1-1/2 inches of side clearance from the rigid insulating barriers to the compartment sides and 1 inch to the compartment access openings.

## 8. . (continued)

- E. Utility compartment covers (i.e., exterior hood and pull section) are sealable and lockable using a padlock with a 1/16-inch lock shaft.
- F. Secure internal equipment (attached to the outer walls of the enclosure) in place with devices that cannot be loosened from the outside. Do not use screws or bolts requiring special tools for installation or removal.
- G. The terminating pull-section of the pedestals:
  1. Comply with the minimum dimensions illustrated in Table 8-2, “Minimum Dimensions: Inches,” on Page 8- .
  2. Accept a minimum 1/2-inch and a maximum 1-inch conduit.
    - Have covers equipped with lifting handles.
    - Are equipped with aluminum-bodied mechanical lugs, ranging from 4/0 through 750 kcmil, for terminating the service conductors. 1-1/2 inch minimum spacing will be provided between the energized lugs or bussing. The 1-1/2 inch spacing may be reduced if rigid insulating barriers (1/16-inch minimum thickness) are provided that extend a minimum of 1/2 inch beyond any exposed, energized part when the maximum wire size is installed.
    - Have insulated cables or busses installed between the termination lugs and the test-bypass facilities.
  6. Have protective metallic barriers, 16-gauge minimum, provided between the pull sections and their (the applicants’) distribution sections.
    - Have a 1/4-inch minimum clearance between the applicants’ section walls and the barriers to prevent screws and bolts from protruding into the pull sections.

For information on structural-mounting requirements and pedestal support, consult your local PG&E project coordinator and meter shop.

Nonresidential Current-Transformer Rated Pedestals, 00 00 mps  
1 or , 00 mps

This subsection provides information on single-metered, current-transformer (CT-) rated metering pedestals from 00 amps up to 800 amps. These pedestals are built with the utility cable termination compartment on the back and with the metering compartment on the front top above the customer section, or a meter panel connected to the side of the pedestal. Refer to Figure 8-1 , “ Nonresidential CT Pedestal ( 00 600 Amps 1Ø or Ø, 800 Amps Ø),” on Page 8-1 , and Figure 8-1 , “ Nonresidential CT Pedestal Side Mount Meter Panel ( 00 600 Amps, 1Ø or Ø, 800 Amps Ø),” on Page 8-1 . These pedestals are only approved for the manufacturers and model numbers listed in Table 8- , “CT Pedestal Approved Manufacturer’s Model Numbers, and Figures” on Page 8-12.

Section 8, Electric Metering: Pedestals

8. . (continued)

Table - CT Pedestal pproved Manufacturer s Model Numbers and Figures<sup>2</sup>.

Manufacturer	Model/Catalog Numbers		Figure
an	CP e es		
es o Cont os	- C	- C	

o en esaenot ste eton eos a atons Pe estas st eet a P e e ents  
na a o a s n t e e  
ese e estas a e on a o e o a s n g e e t e s o e t a t s e o t a g e s a n a e a g e s e e  
e t o n a e a o e t n g e e t e P a n e e e e n t on Page o a s o e t  
e e ents  
o o - o e s t o a s e e t o g e o P o e t o a e e e t o n t C  
C o a t e n t o n e g o n e e on Page

*cited in Cal. Rest. Ass'n v. City of Berkeley  
No. 21-16278am archived December 27, 2023*

8. . (continued)

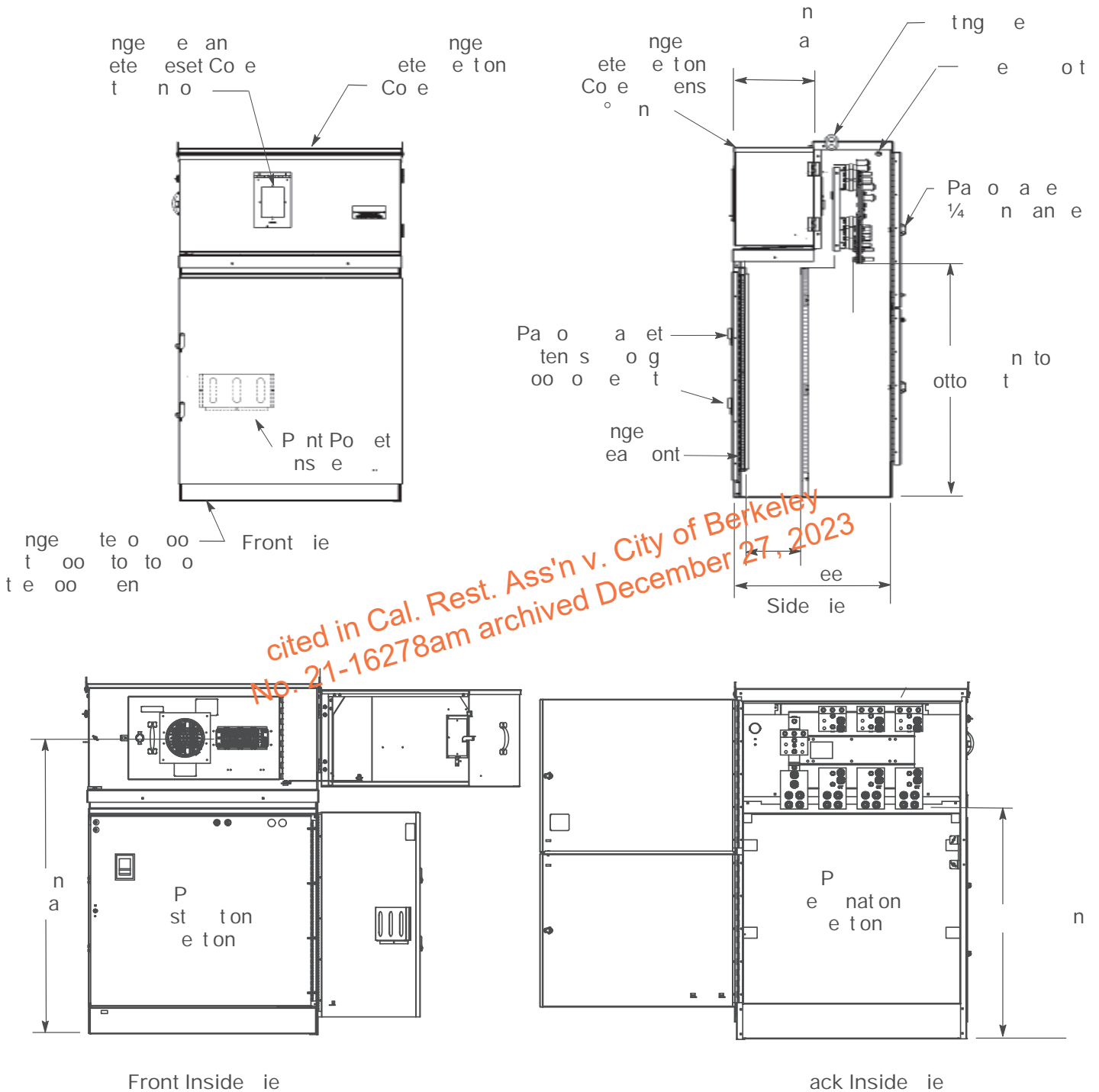
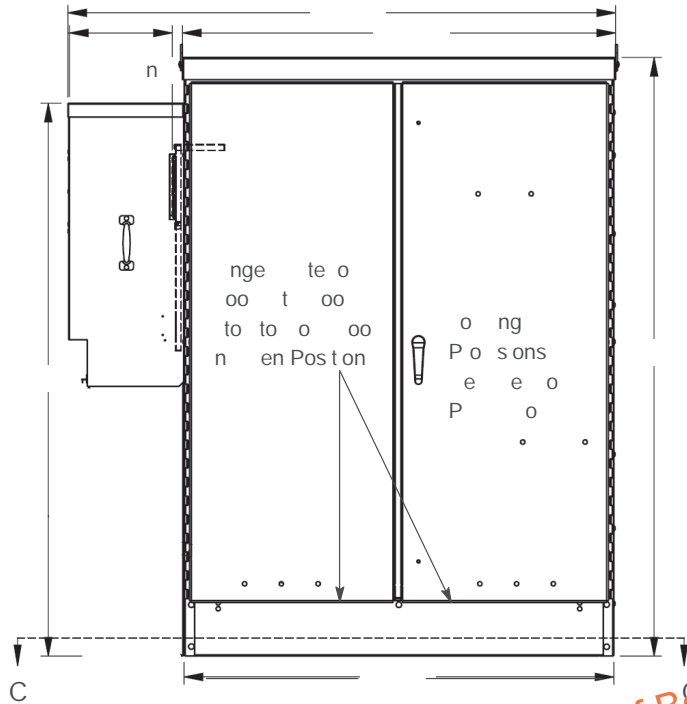


Figure -1  
 Nonresidential CT Pedestal  
 ( 00 00 mps 1Ø or Ø, 00 mps Ø)



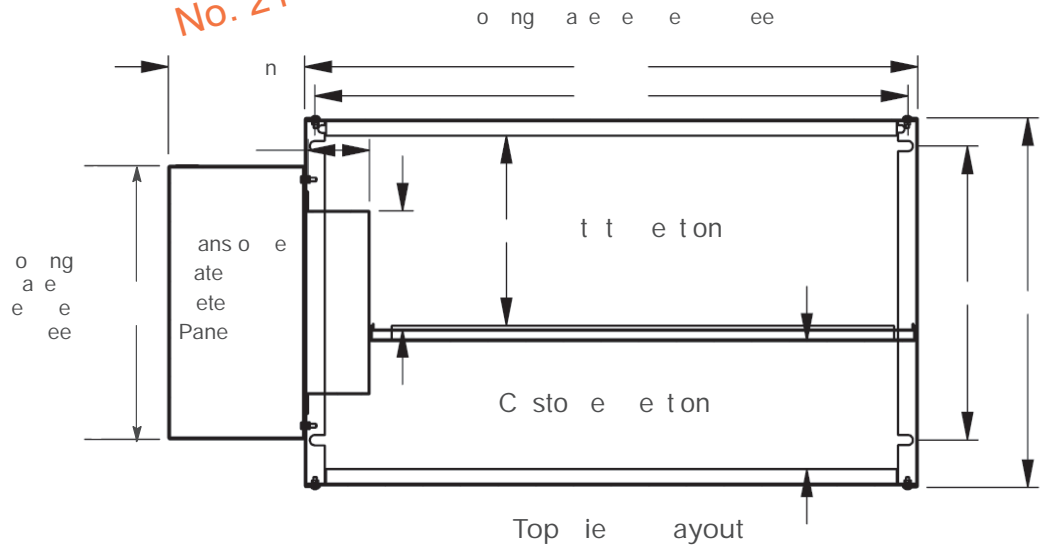
Section 8, Electric Metering: Pedestals

8. . (continued)



Front Side Mount Meter Panel

*cited in Cal. Rest. Ass'n v. City of Berkeley  
 No. 21-16278am archived December 27, 2023*



Top Layout

Figure -1  
 Nonresidential CT Pedestal Side Mount Meter Panel  
 (1000 mps, 1Ø or Ø, 1000 mps Ø)

8. . (continued)

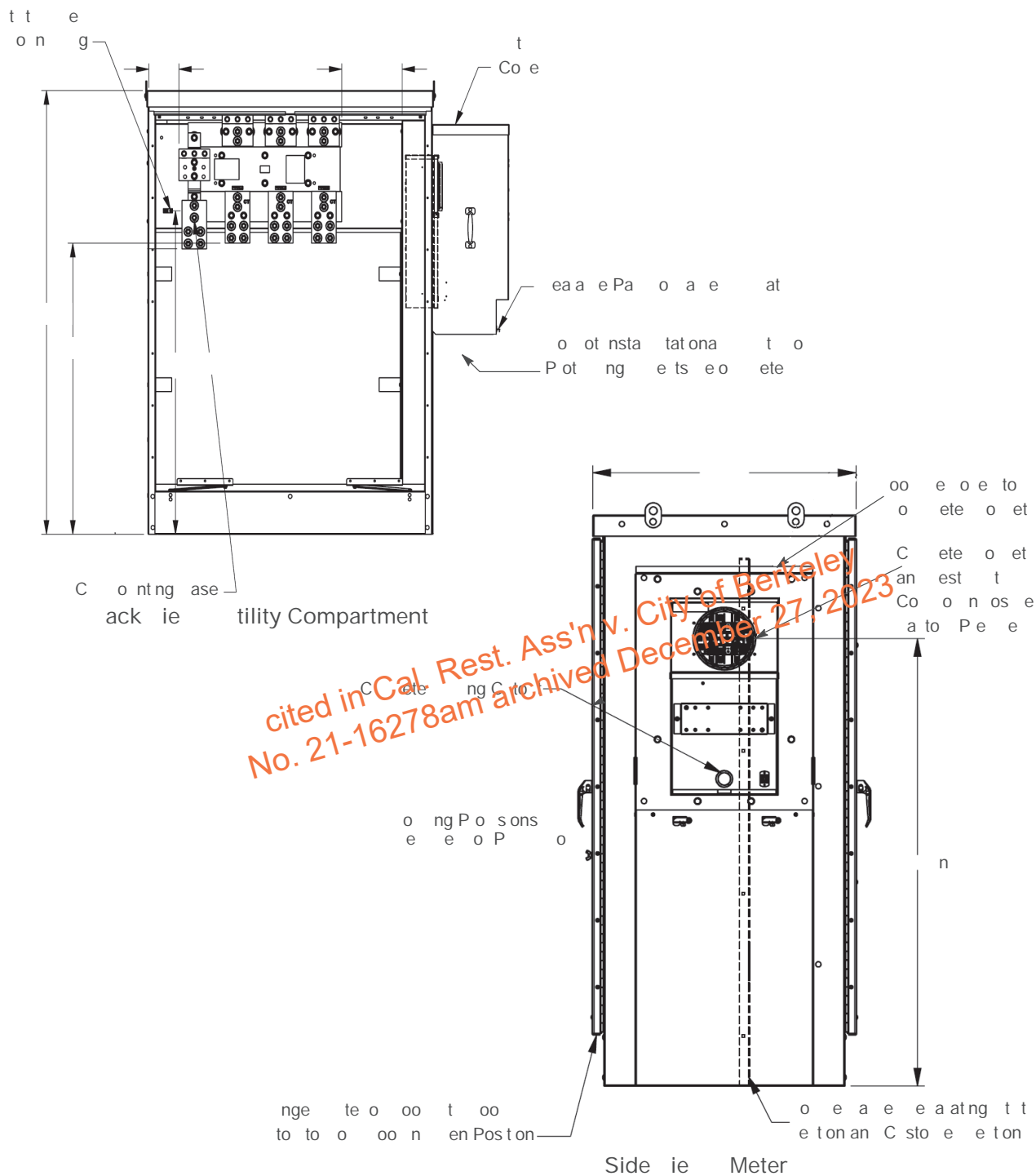


Figure -1 (continued)  
 Nonresidential CT Pedestal Side Mount Meter Panel  
 ( 00 00 mps, 1Ø or Ø, 00 mps Ø)

This Page Intentionally left Blank

*cited in Cal. Rest. Ass'n v. City of Berkeley  
No. 21-16278am archived December 27, 2023*

SECTION ELECTRIC METERING: COMPONENTS AND  
TERMINATING FACILITIES

SECTION  
ELECTRIC METERING:  
COMPONENTS AND C  
TERMINATING FACILITIES

*cited in Cal. Rest. Ass'n v. City of Berkeley  
No. 21-16278am archived December 27, 2023*

SECTION ELECTRIC METERING: COMPONENTS ND  
C E TERMIN TING F CI ITIES

*cited in Cal. Rest. Ass'n v. City of Berkeley  
No. 21-16278am archived December 27, 2023*

## Section

### Electric Metering: Components and Cable Terminating Facilities

---

#### 1 Scope

This section of the manual provides detailed information on individual electric metering components and underground service cable termination compartments or sections that Pacific Gas and Electric Company (PG&E) finds acceptable for use in electric metering and service construction projects.

The [Electric Utilities Service Equipment Requirements Committee \(EUSERC\)](#) book, Section 00, contains service and meter-equipment details for PG&E-approved components, as well.

#### 2 Test Blocks for Self-Contained Metering, 0 mps Through 22 mps

A test block is a specific type of test-bypass device. A test block differs from a test-bypass facility, which is any mechanism used to bypass meter sockets. Both test blocks and test-bypass facilities are used for self-contained metering exclusively.

Applicants must ensure that test blocks meet the following requirements.

- A. The hex nut must measure  $\frac{1}{8}$ -inch across flats with a copper washer attached. The hex nut must de-energize the meter socket when backed off.
- B. Stud A, located at each conductor terminal, is used to bypass the applicant's load current. Applicants must ensure that these studs are used as described in the following three bullets.
  - Stud A must be located in the clear area between the terminating lug and the circuit-closing nut.
  - Stud A may be positioned on the terminal body, on the terminal screw, or on the bus member.
  - Stud A may be incorporated as part of the wire stop.
- C. Terminals must be aluminum-bodied and suitable for copper and aluminum conductors. The terminal screw may be an Allen type,  $\frac{1}{16}$ -inch across flats for 100-ampere meters, or  $\frac{1}{16}$ -inch across flats for 200-ampere meters.
- D. If Stud A is a part of the terminal screw, the terminal screw must be a  $\frac{1}{8}$ -inch hex.

9. . (continued)

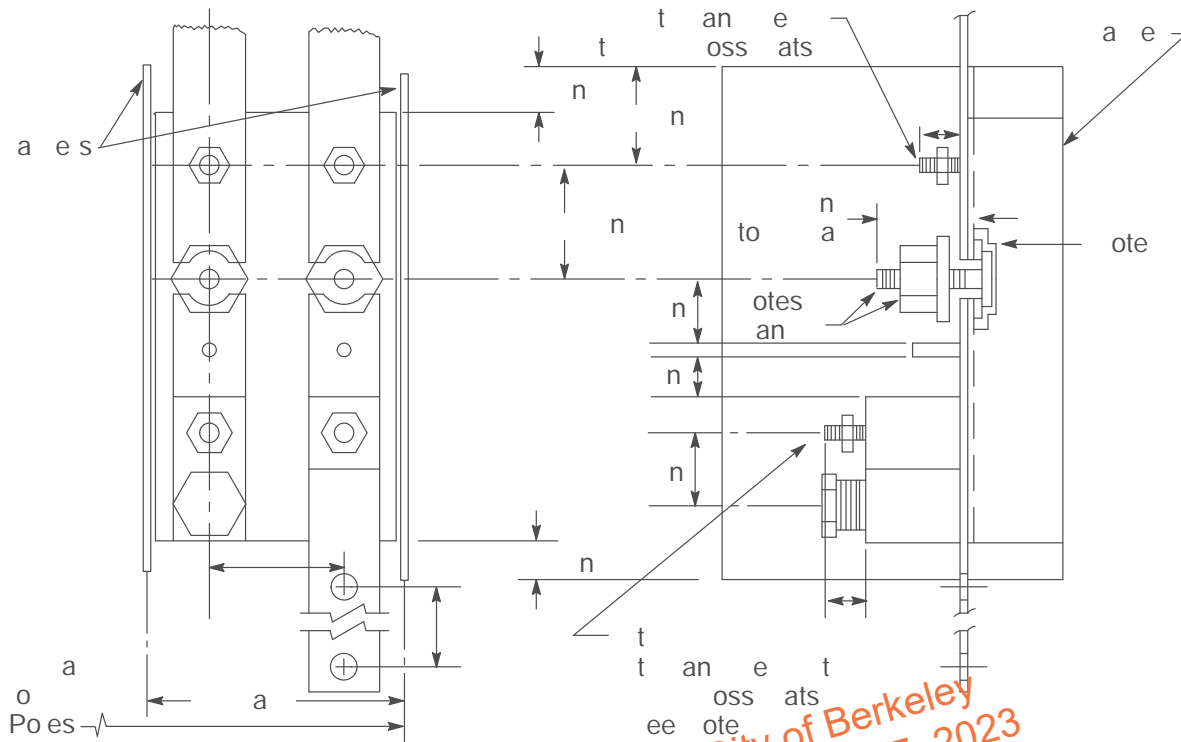


Figure 1  
 Test locks for Self-Contained Metering, 0 mps-22 mps  
 cited in Cal Rest Ass'n v. City of Berkeley  
 No. 21-16278am allowed December 27, 2023

notes in reference to Figure 941

1. A hex nut (i.e., 7/8-inch across flats with a copper washer attached) de-energizes the meter socket when backed off.
  2. Stud A, located at each conductor terminal, permits PG&E to bypass the applicant's load current. Locate Stud A in the clear area between the terminating lug and the circuit-closing nut. Stud A may be positioned on the terminal body, on the terminal screw, on the bus member, or incorporated as part of the wire stop.
- . Terminals must be aluminum-bodied and suitable for copper and aluminum conductors. The terminal screw may be an Allen-type (i.e., 1/16-inch across flats for 100-amp meters or 1/16-inch across flats for 200-amp meters). If Stud A is a part of the terminal screw, the terminal screw must be a 7/8-inch hex.
- . Do not use an automatic bypass or manual lever bypass. These types of test blocks are not allowed.

## Test Switch Mounting Base Detail

Figure 9-2, below, shows the base dimensions for mounting a removable test switch.

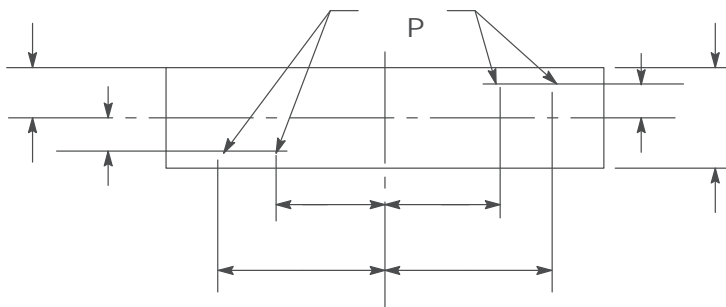


Figure 9-2  
Removable Test Switch Mounting Base Detail

Separate CT Cabinet, 201 Amps and Above, Single Phase and Three Phase  
Applicants must ensure that cabinets meet the following requirements.

- A. All covers are sealable.
- B. Outdoor current transformer (CT) cabinets are weatherproof.
- C. Grounding lugs are provided.
- D. CT cabinets are not used as splicing chambers.
- E. CTs are not tapped off to supply other meters or used by applicants for any other purposes.
- F. PG&E's underground service-lateral conductors do not terminate in CT cabinets.



Section 9, Electric Metering: Components and Cable Terminating Facilities

9. . (continued)

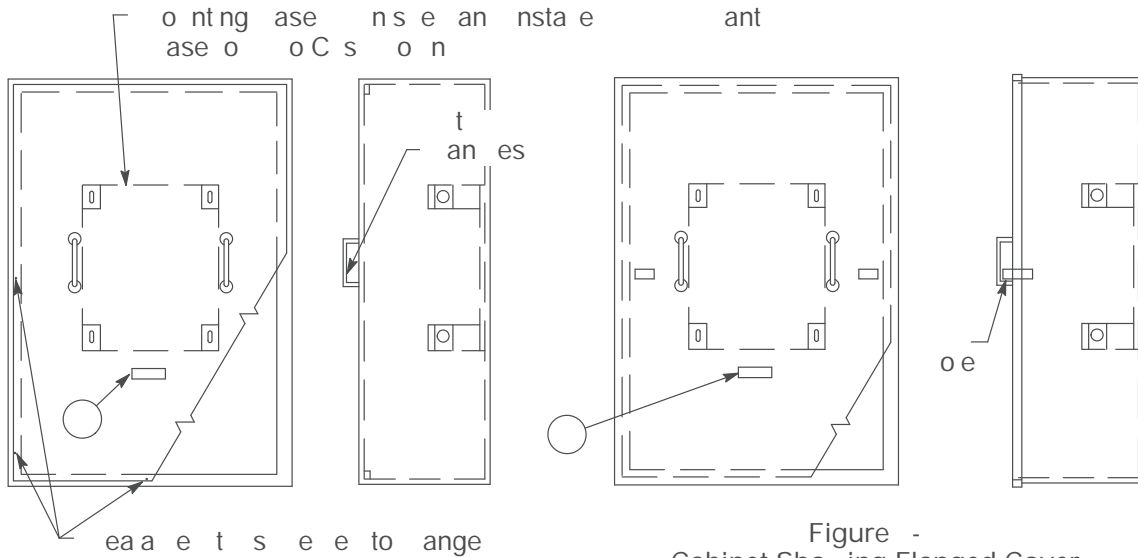


Figure - Cabinet Showing Stud-Mounted Cover

Figure - Cabinet Showing Flanged Cover Fastened by Sealable Rivetatches

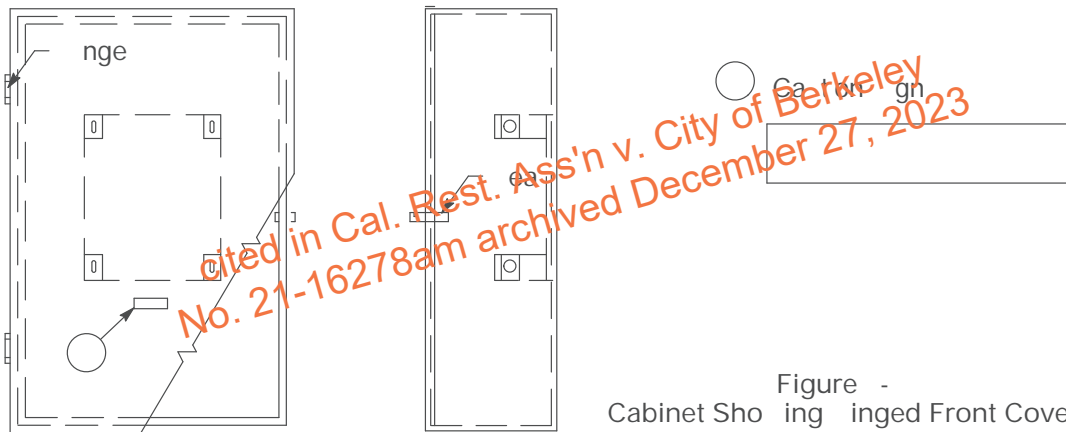


Figure - Cabinet Showing Hinged Front Cover

Table -1 CT Cabinet Minimum Dimensions

Type of Service	Cabinet Size (in Inches)	CT Mounting Base	CT Cabinet
e Ø		g e	g e
e Ø		g e	g e

CT Mounting base, 201 mps Through 00 mps

Applicants must ensure that all of the required bolts are furnished and that conductors are connected to the line and load terminals on the CT mounting base. Also, the ampacity rating of the mounting base must not be greater than the PG&E service rating.

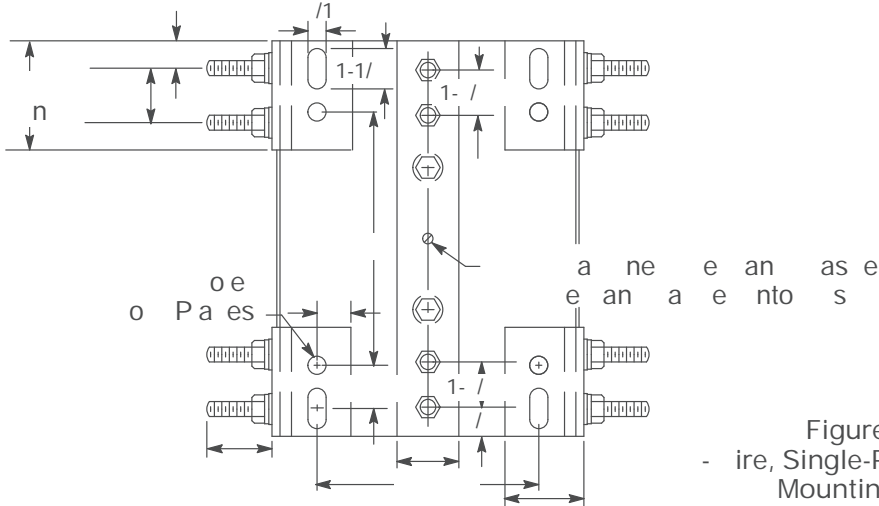


Figure -  
- ire, Single-Phase Service,  
Mounting ase

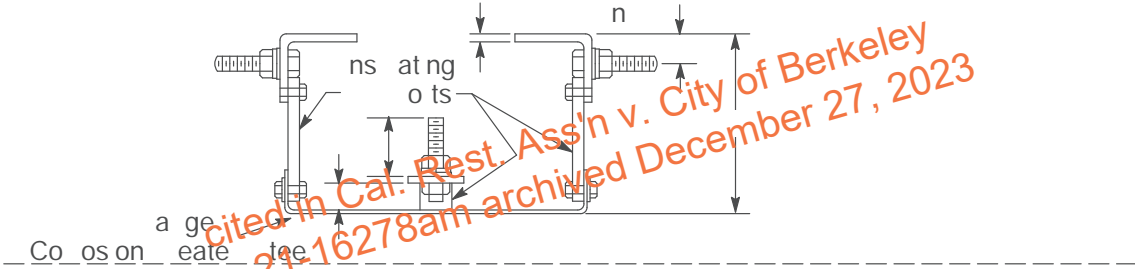


Figure -7  
- ire, Three-Phase  
Service, Mounting  
ase

*Cited in Cal. Rest. Ass'n v. City of Berkeley  
No. 21-16278am archived December 27, 2023*

Section 9, Electric Metering: Components and Cable Terminating Facilities

Alternate CT Mounting Base, One Phase or Three Phase

Applicants must ensure that mounting bases meet the following requirements.

- A. Insulated supports are rated for the serving voltage and have sufficient mechanical strength for the application.
- B. Mounting bases only accept bar-type CTs.
- C. Two 1/2-inch steel, Grade 5 bolts are provided for each cable-terminating and CT-mounting position. Each bolt must be furnished with a 2 1/4-inch diameter Belleville washer and a nut. Bolts must be secured in place and spaced as shown in all figures. All parts must be plated to prevent corrosion.
- D. The ampacity rating of the mounting base must not be greater than the PG&E service rating being supplied.

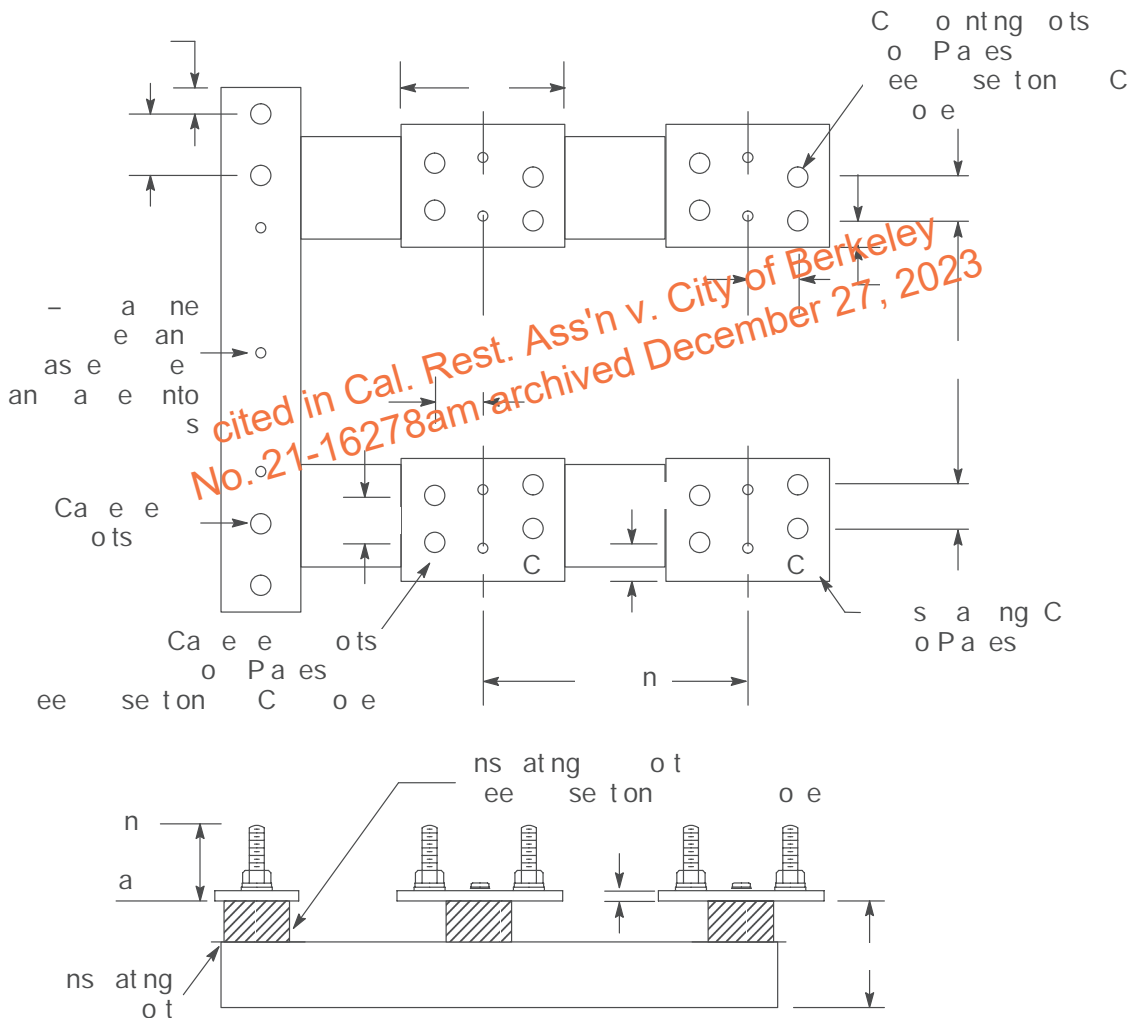


Figure -  
 CT Mounting Base  
 (Single-Phase, 120V, 100 mps, 100 mps, 0 volts- 00 volts)

9.6. (continued)

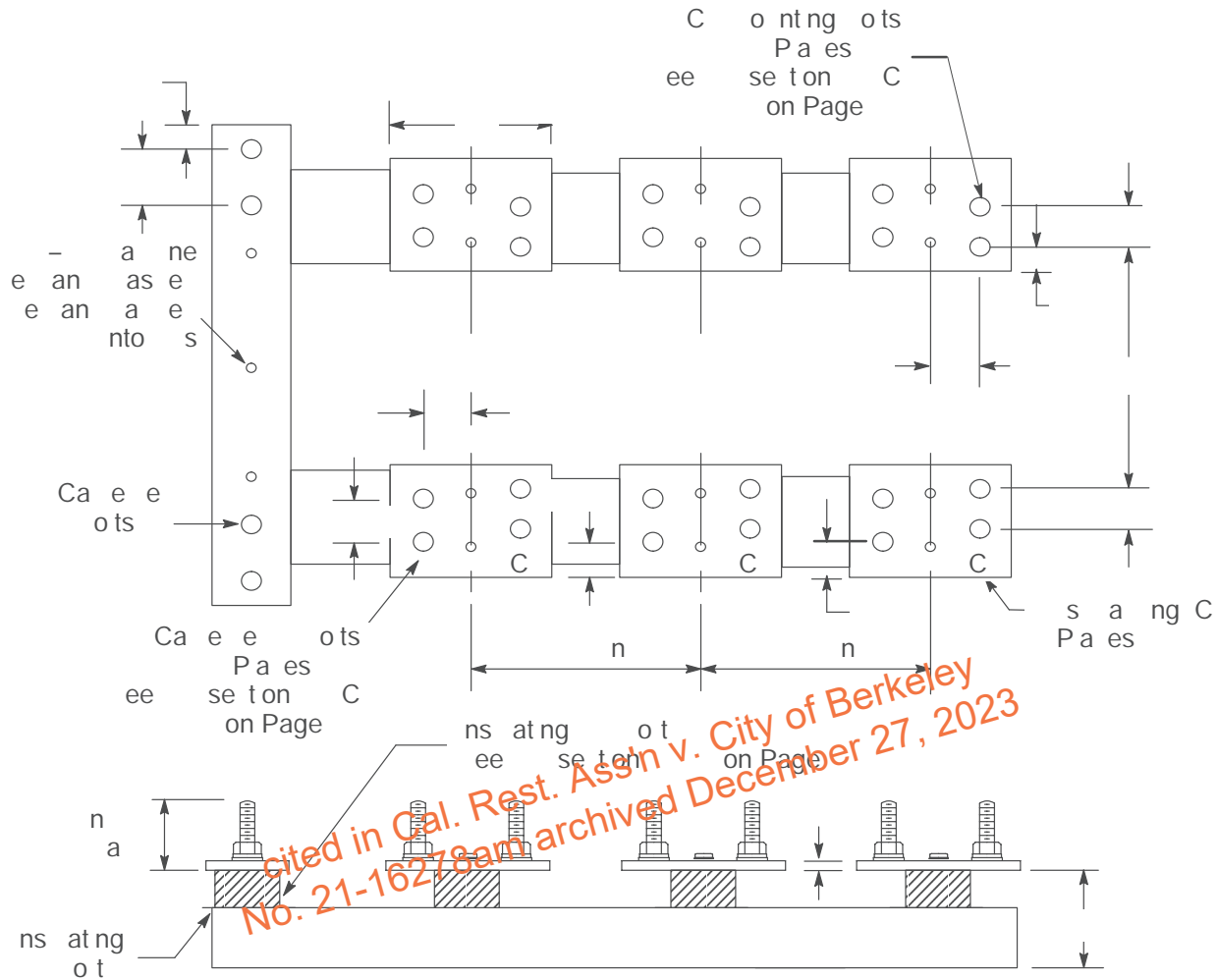


Figure -  
CT Mounting Base  
(Three Phase, - wire, 00 mps, 00 mps, 0 olts, 00 olts)

notes in reference to Figure 9-8 on Page 9-6 and Figure 9-9 above.

1. CT mounting bases rated for 600 amps and 800 amps are allowed only for select types of wall-mounted and pad-mounted service termination and metering equipment.

7 used CT Cabinet, - ire Service, 201 mps Through 00 mps

Applicants must ensure that cabinets meet the following requirements.

- A. All covers are sealable.
- B. Outdoor CT cabinets are weatherproof.
- C. Grounding lugs are provided.
- D. Neutral or unmetred wiring, either cable or bus bar, is located on either side of the cabinet.
- E. CT cabinets are not used as splicing chambers.
- F. PG&E's underground service lateral conductors do not terminate in CT cabinets.
- G. For Virtual Net Energy Metering ( VEM) and Net Generation Output Meter ( NGOM) applications only, CT cabinets rated at 600-800 amps may be allowed, including multiple cables per phase on the line and load side of this CT cabinet.
  - limited to a maximum of 00 amps for overhead services.

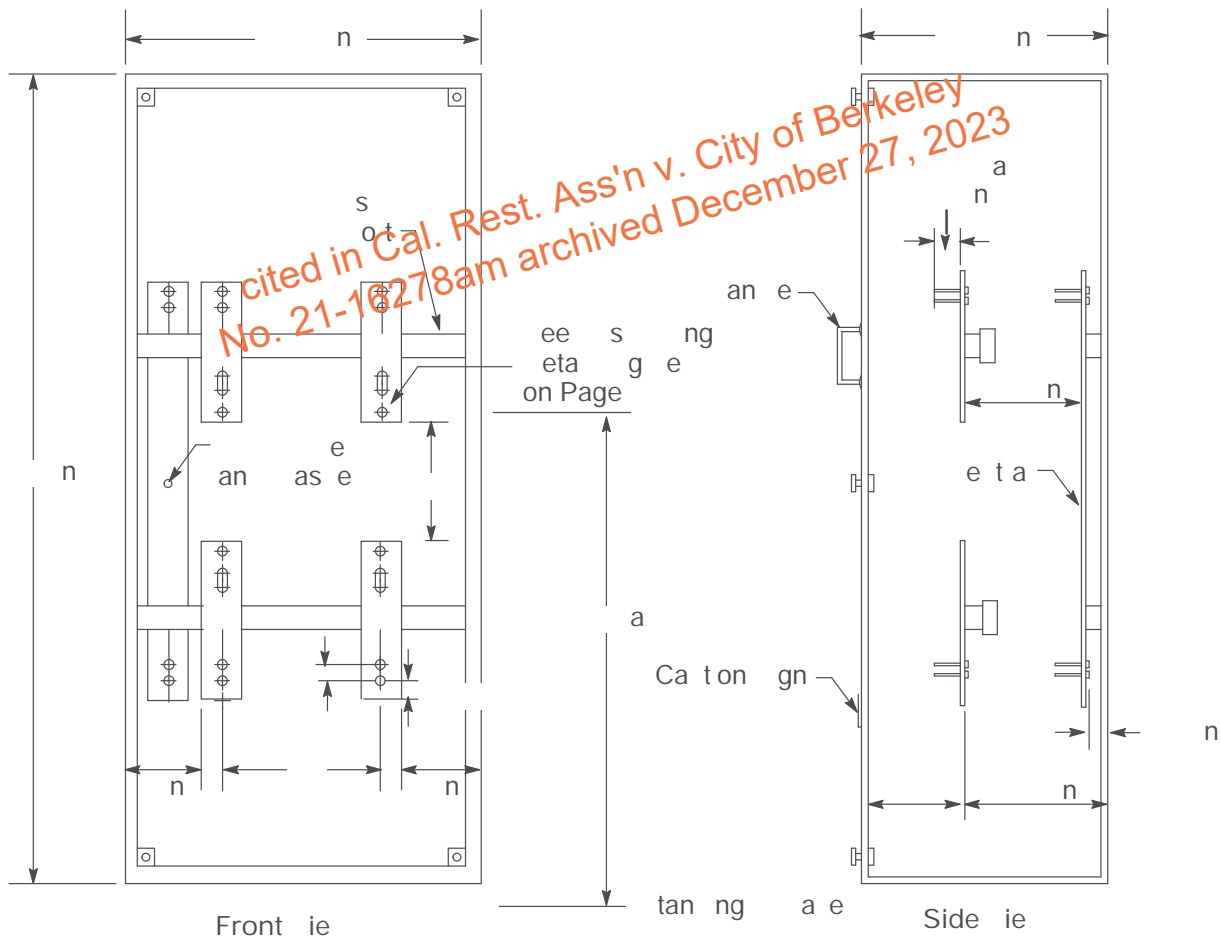


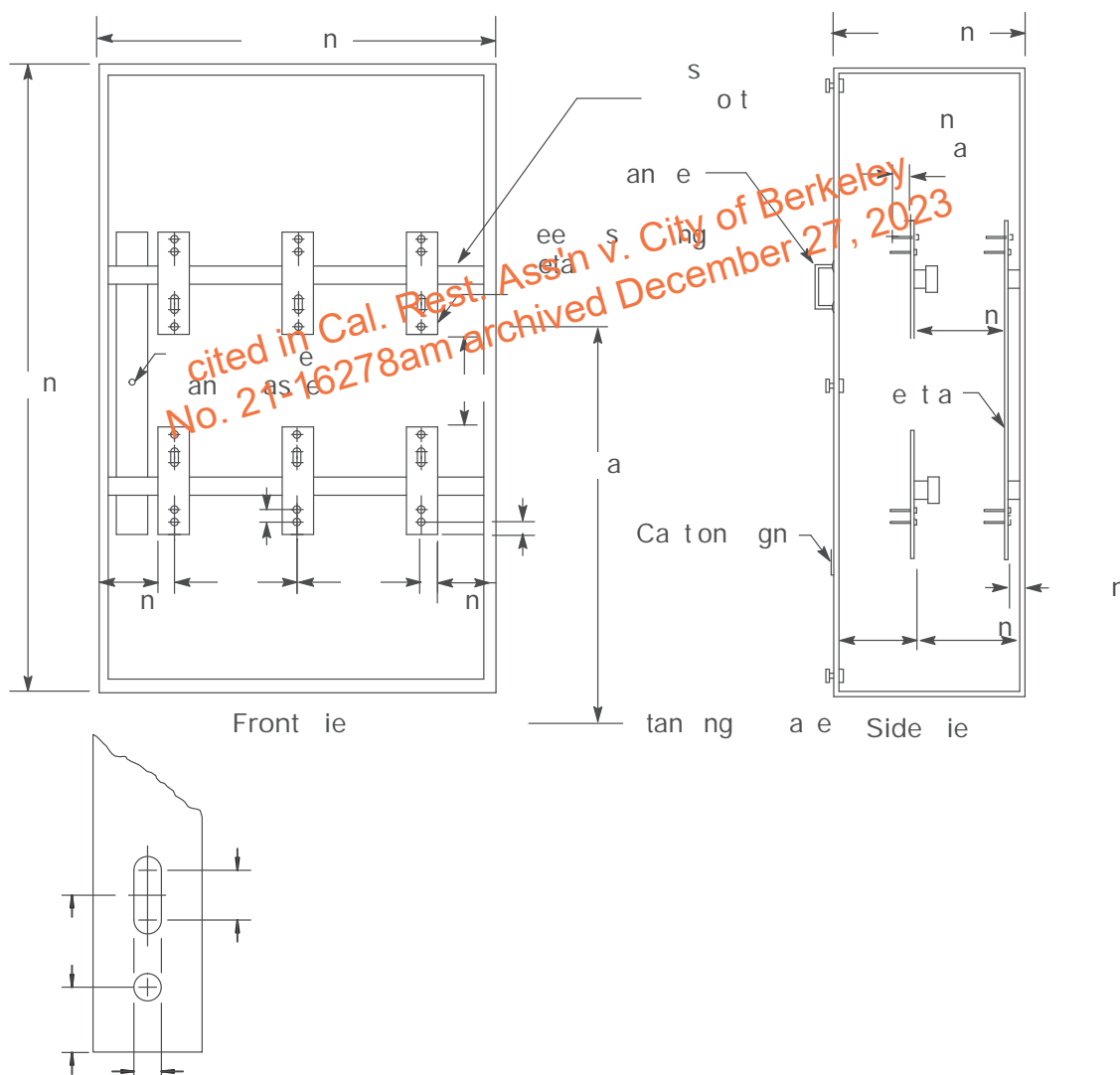
Figure -10 used CT Cabinet, - ire Service, 00 mps- 00 mps

Section 9, Electric Metering: Components and Cable Terminating Facilities

used CT Cabinet, - ire Service, 00 mps

Applicants must ensure that cabinets meet the following requirements.

- A. All covers are sealable.
- B. Outdoor CT cabinets are weatherproof.
- C. Grounding lugs are provided.
- D. Neutral or unmetered wiring, either cable or bus bar, is located on either side of the cabinet.
- E. CT cabinets are not used as splicing chambers.
- F. PG&E's underground service lateral conductors do not terminate in CT cabinets.
- G. For EM and GOM applications only, CT cabinets rated at 600 800 amps may be allowed, including multiple cables per phase on the line and load side of this CT cabinet.



*cited in Cal. Pest. Ass'n v. City of Berkeley  
No. 21-16278am archived December 27, 2023*

Bus Drilling Detail

Figure -11  
used CT Cabinet ( - ire Service, 00 mps Ma )

### Meter Socket for Transformer-Rated Metering

Applicants must ensure that meter socket jaw requirements and connections are made according to the rules in [Section 9, "Electric Metering: General," Subsection 9.6., "Meter Types and Connections,"](#) on Page 9-26.

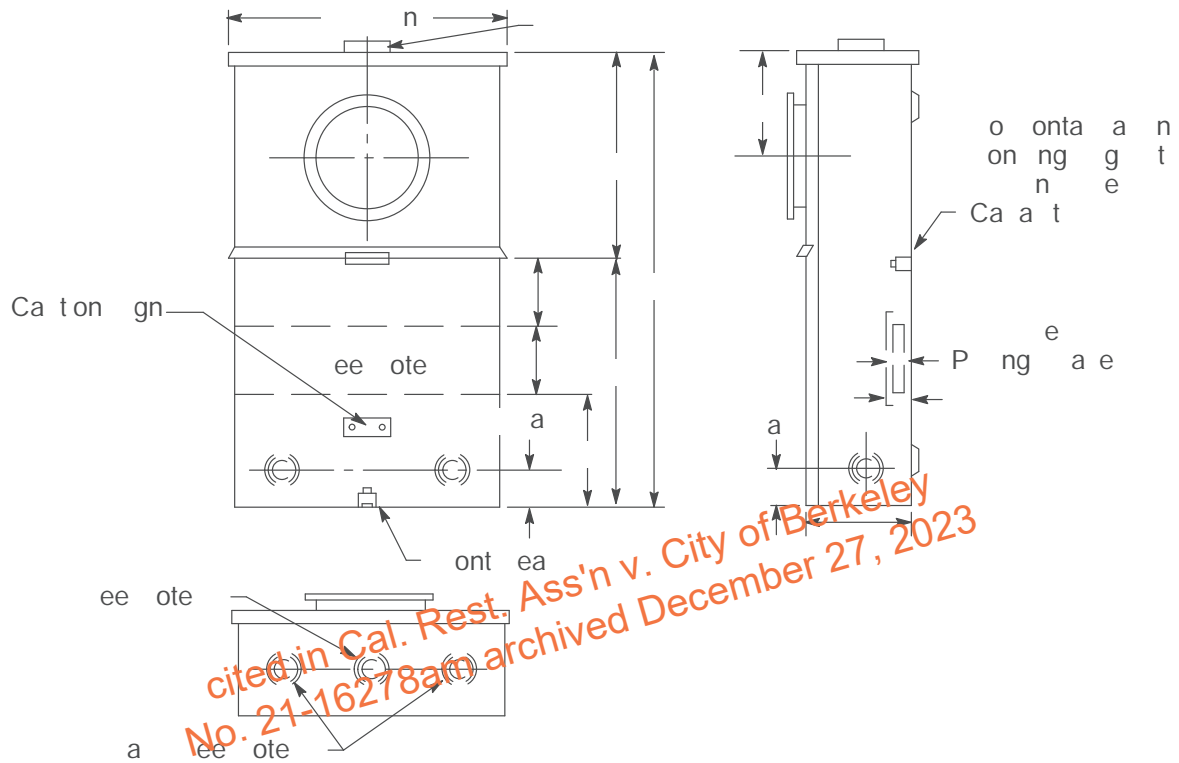


Figure 9-12  
Meter Socket for Transformer-Rated Metering  
(Single-Phase or Three-Phase Installations)

Notes in reference to Figure 9-12.

1. Location of mounting bracket for test switch or reactive transformer.
2. .O.-knock out

Section 9, Electric Metering: Components and Cable Terminating Facilities

9.9. (continued)

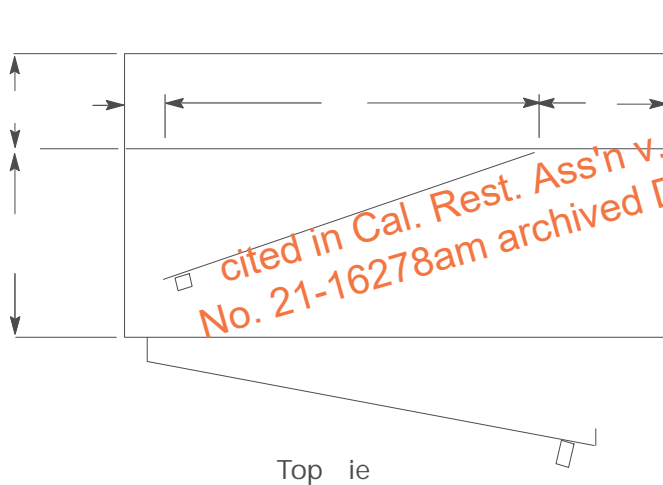
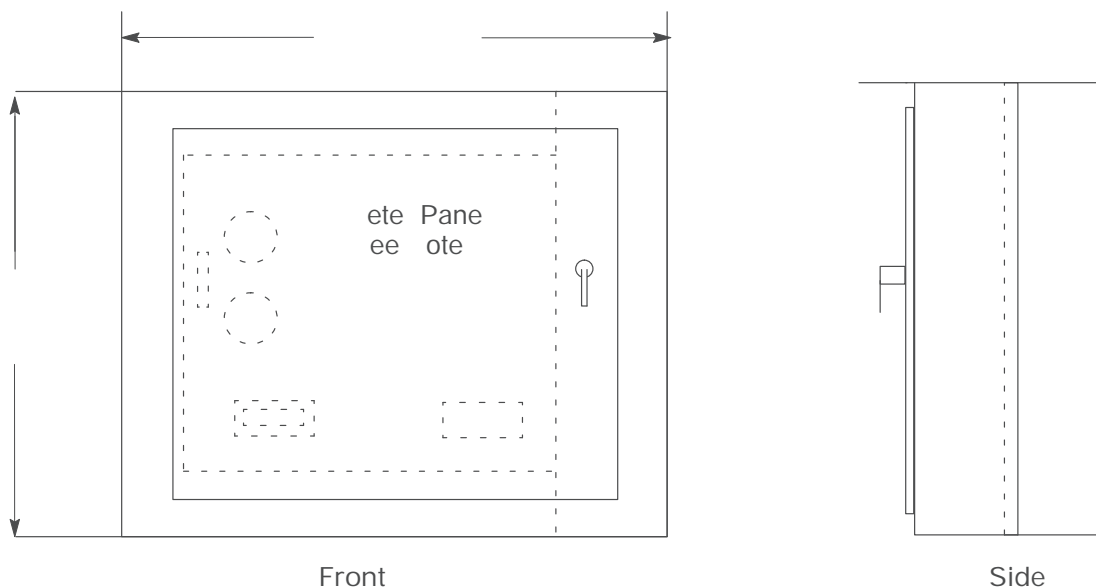


Table 9-2 Ringed Meter Panel Requirements

Service Voltage	Switch Rating	Ringed Panel Required
Ø	an	es
Ø	an	es
Ø	an	es

Figure 9-1 Remote Metering Cabinet (Three-Phase Installations)

Notes in reference to Figure 9-1 .

1. The enclosure must be:
  - a. Equipped with a device to secure the door in the open position at 90° or more.
  - b. Secured in the closed position with a handle-operated latching mechanism, and lockable with a padlock having a 1/16" lockshaft.
2. For meter panel requirements, see [Section 10, Figure 10- 0, "Standard Switchboard Service Section, 0-Inch Panel for Socket Meters and Recorder,"](#) on Page 10- .
  - a. Written information must be provided and marked inside of the meter panel. This information must include:
    - a. Potential Transformer/Current Transformer (PT/CT) designation (Type)
    - b. Rating Factor ( F)
    - c. Burden
  - b. Remote metering must be approved by the the local meter shop before installation.
  - c. See Table 9-2, " Ringed Meter Panel equirements," above.



## 10 Underground Service Cable-Termination Compartments or Sections

Applicants must ensure that underground service-termination compartments or sections meet the following requirements.

- A. The termination compartment covers must be removable, sealable, provided with two lifting handles, and limited to a maximum size of 9 square feet.
- B. The cover panel can be sealed using two drilled stud-nut and wing-nut assemblies on opposite sides of the panel.
- C. The minimum dimensions specified in Table 9- , “Minimum all-Mounted Pull-Section Dimensions: Residential and Nonresidential, Single-Phase or Three-Phase,” on Page 9-1 , are used when the service conduit enters the bottom of the termination compartment or termination enclosure and all load conductors exit above the terminals. When the service conduit enters from the side or back of the pull box, use the dimensions from the closest portion of the conduit to the nearest termination bolt.
- D. Applicants must not use wall-mounted service-termination and pull enclosures for three-phase, nonresidential installations rated 01 amps through 2, 00 amps. See Table 9- , “Minimum Pad-Mounted (Floor-Standing) Switchboard Pull-Section Dimensions: Residential and Nonresidential, Single-Phase and Three-Phase,” on Page 9-1 , and [Section 10, Table 10-1, “Minimum Bottom-Fed Pull Section Dimensions,”](#) on Page 10-2, for bottom-entry installation requirements. See [Table 10-2, “Pull Section Dimensions \(Minimums\) Below Ground Level,”](#) on Page 10- 1, for side-entry or back-entry requirements.
- E. A PG&E project coordinator is contacted when developing nonresidential, 01-amps-and-above services. Applicants must ensure that they meet PG&E’s requirements for underground service-termination pull boxes, which include the following:
  1. Installing multiple sets of utility service cables.
  2. Provide stacking provisions (i.e., bolts) to terminate cables in any three-phase installation that is 1,200 amps or greater.
  3. Providing additional space (i.e., depth, width, and termination height), when required, in any section of switchboard, panel board, or other enclosure intended as a termination point for PG&E’s service cables. This additional space will provide the mandatory clearances between phases and grounded surfaces, as well as accommodate the installed service cables.

See [umbered Document 06 928, “Methods and Requirements for Installing on- Residential Underground Electric Services 0 600 Volts to Customer-Owned Facilities,”](#) for the appropriate conduit and cable requirements to use when designing nonresidential service installations. This document is included in [Appendix C, “Electric and Gas Engineering Documents.”](#)
- F. See additional requirements for pad-mounted switchboards in [Section 10, Subsection 10. 1 ., “Underground, Cable-Terminating Facilities in Pull Boxes or Pull Sections,”](#) on Page 10- . The information and figures describe additional requirements for applicants who install these facilities.

Section 9, Electric Metering: Components and Cable Terminating Facilities

9.10. (continued)

Table - Minimum Wall-Mounted Pull-Section Dimensions: Residential and Nonresidential, Single-Phase<sup>1</sup> or Three-Phase<sup>1</sup>

Service Rating (amps)	Minimum Access Opening					
	Front	Side	Bottom Entry	Side/Rear Entry	Bottom Entry	Rear Entry
15	12	12	12	12	12	12
20	12	12	12	12	12	12
30	12	12	12	12	12	12
60	12	12	12	12	12	12

Notes: 1. The minimum access opening dimensions are for a single-phase service. For three-phase service, the minimum access opening dimensions are as shown in Table 9-1. 2. The minimum termination height is 0-1/2 inches for bottom-fed service sections only as shown in Section 9, Figure 9-1 on Page 9-8 and Section 10, Figure 10-16 on Page 10-2. 3. The height dimension is measured from the bottom of the enclosure to the first phase bolt.

Table - Minimum Pad-Mounted (Floor-Standing) Switchboard Pull-Section Dimensions: Residential and Nonresidential, Single-Phase and Three-Phase

Service Rating (amps)	Minimum Access Opening		Termination Height
	Front	Side	
15	12	12	0-1/2 inches see note 1
20	12	12	
30	12	12	
60	12	12	
100	12	12	

Notes in reference to Table 9-1 and Table 9-2:

1. If termination bus-landing stubs are installed perpendicular to the back of the board, a wider enclosure dimension will be required to accommodate the installation of PG&E's cables.
2. Maintain a clear working space. When return flanges are necessary, ensure they do not intrude into service-conductor space.
  - . Dimension 1 is the minimum width of the pull section access opening.
  - . The minimum termination height is 0-1/2 inches for bottom-fed service sections only as shown in Section 9, Figure 9-1 on Page 9-8 and Section 10, Figure 10-16 on Page 10-2.
  - . The height dimension is measured from the bottom of the enclosure to the first phase bolt.

9.10. (continued)

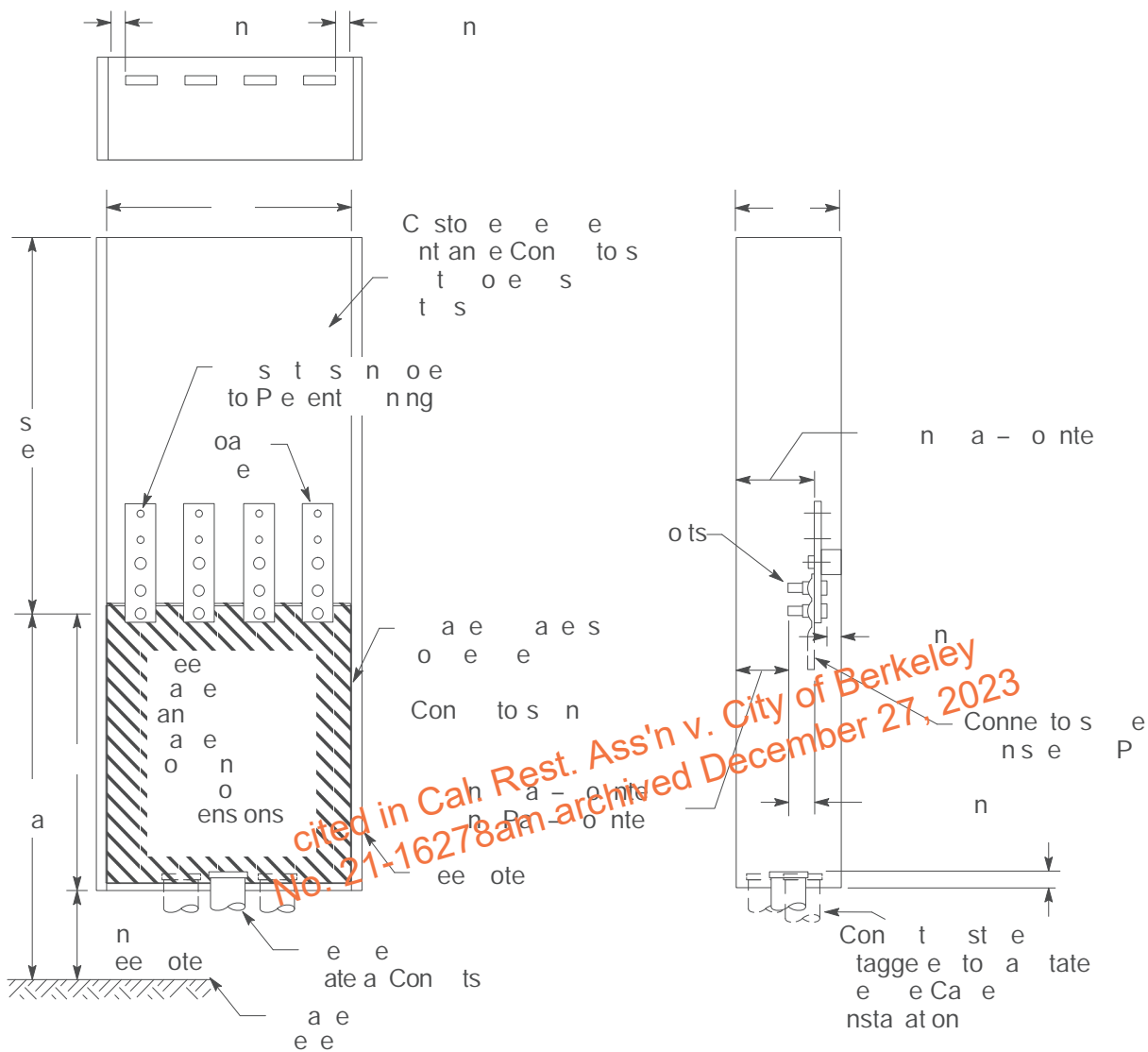


Figure 9-1  
Typical Underground Service Termination Section and Pull Box, Floor-Mounted or Pad-Mounted (Floor-Standing)

Notes in reference to Figure 9-1 .

1. Ensure that pull-box covers are removable, sealable, provided with two lifting handles, and limited to a maximum size of 9 square feet. Sealing provisions must consist of two drilled stud-and-wing nut assemblies on opposite sides of the panel. Ensure that all security screws are captive.
  2. Maintain a clear working space. When return flanges are necessary, ensure that they do not intrude into service conductor space (designated by shading).
- . The 6-inch minimum height requirement from grade to panel does not apply for a floor-standing switchboard.
  - . A main service switch rated at 2, 01 amps and above requires bus-duct configuration.

Notes continued on the next page

9.10. (continued)

otes in reference to Figure 9-1 , continued.

- . ugs for terminating the customer's ground wire (or other grounding conductors) must be located outside of the sealable section and must be designed to readily permit the customer's neutral system to be isolated, when necessary, from the serving agency.
- 6. Ground buss, when provided, must be located at the rear of underground terminating enclosures (i.e., pull boxes and pull sections).
- . Switchboard pull and termination sections must not contain line/supply side cable tap connections. A dedicated tap section or a dedicated termination enclosure must be installed.

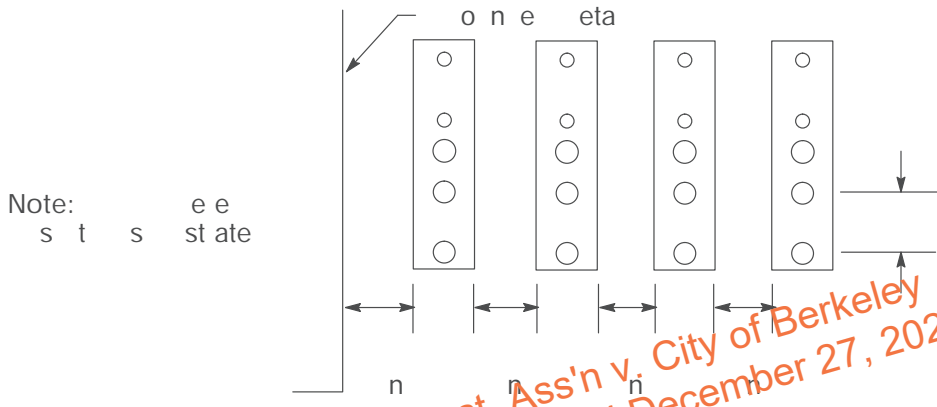


Figure 9-1 Detail of Clearance Requirements for Adjacent Termination Bus Stubs

*cited in Cal. Rest. Ass'n v. City of Berkeley*  
*No. 21-16278am approved December 27, 2023*

9.10. (continued)

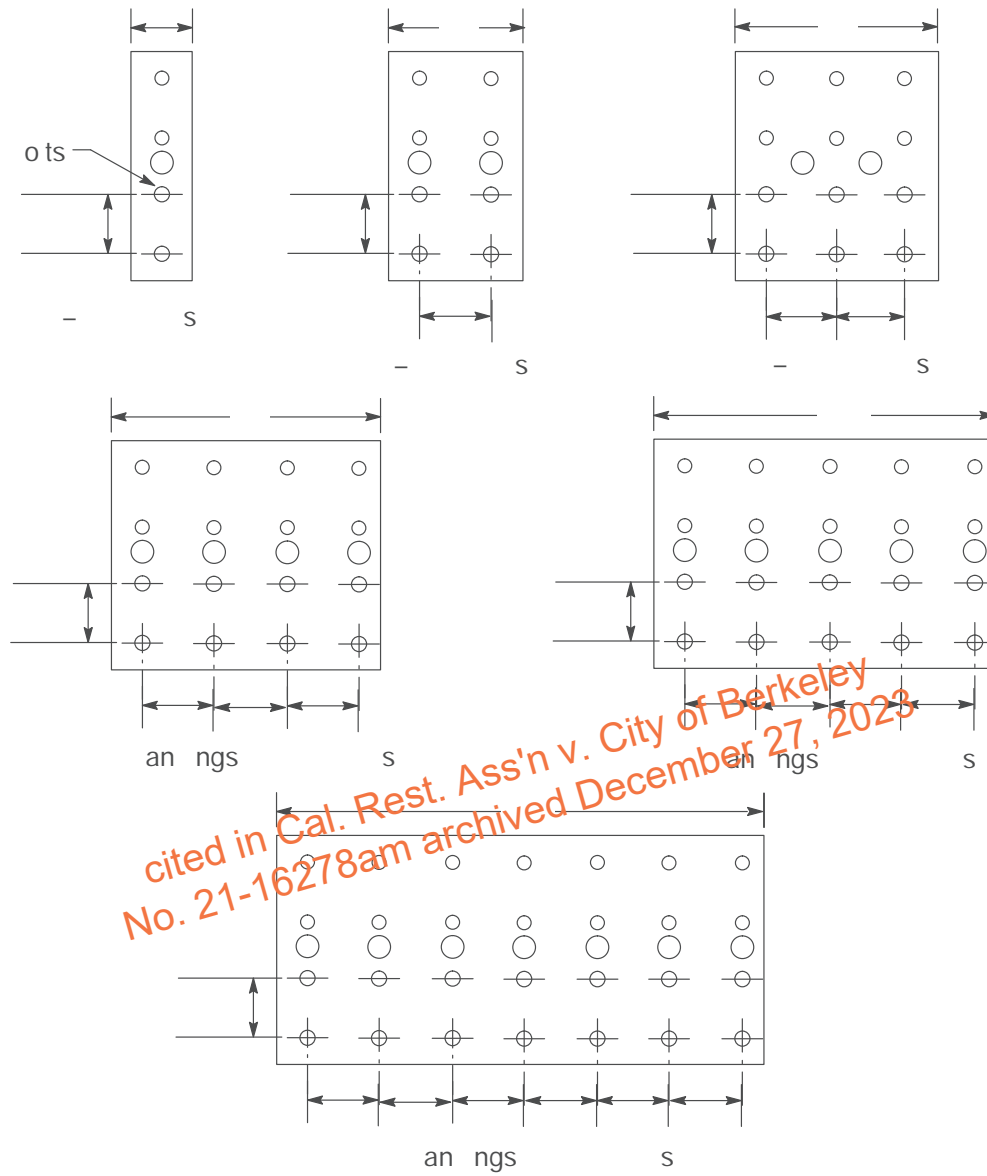


Figure -1  
Detail of Aluminum Termination Bus Stubs

11 Approved Service-Terminal Conductor Connectors

Applicants must observe the following requirements when they plan to install approved, service-terminal conductor connectors.

- A. Applicants must furnish and install PG&E-approved, range taking connectors, suitable for aluminum conductors, for enclosures rated at 0 through 22 amps.
- B. PG&E must furnish and install approved, cable-to-flat-bar connectors on the termination bus stub, as specified in Table 9- , “Approved, Compression-Type Service-Terminal Connectors,” on Page 9-18, for enclosures rated above 22 amps. For a Class 20-amp panel, cable-to flat-bar connectors on the termination bus stub are preferred however, 20-amp-rated meter panels with hex lug terminations are acceptable also.
- C. Applicants may use one-bolt, bus attachment connectors for 0- through 22 -amp services i the connectors are anchored to prevent the connector assembly from twisting.

Applicants must not use pin termination connectors to install cables larger than those intended for the range-taking connectors in their service panel or service enclosure.

NOTE: Do not peel stranded cables to fit conductors into termination connectors.

See PG&E [umbered Document 01 2 1, “Connectors for Insulated Cables Underground Distribution Systems,”](#) Table 28, “Specifications for Terminal Connectors–Aluminum Cable-to-Flat-Bar,” Page 26 for more information. This document is included in [Appendix C](#).

*cited in Cal. Post-App. v. City of Berkeley  
No. 21-16278am archived December 27, 2023*

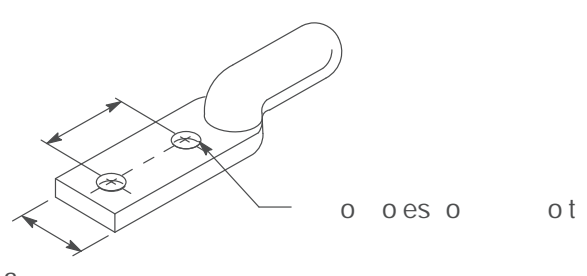


Figure -17  
Service-Terminal Conductor Connector

9.11. (continued)

Table - Approved, Compression-Type, Service-Terminal Connectors

Conductor Size: G or kcmil	Manufacturer and Catalog Number						Tool Index Number
	Manufacturer	Model	Brand	Electrical Specialty	Manufacturer Company	Code	
				P			
				P			
				P			
			C	P			

cited in Cal. Rest. Ass'n v. City of Berkeley  
No. 21-16278am archived December 27, 2023

SECTION 10  
ELECTRIC SERVICE RATES:  
0 Volts T R G 00 0 TS

*cited in Cal. Rest. Ass'n v. City of Berkeley  
No. 21-16278am archived December 27, 2023*

SECTION 10 ELECTRIC SERVICE RATES:  
T R G 00 0 TS



SECTION 10 ELECTRIC S ITC 0 RDS: 0 olts  
T R O G 00 0 TS

*cited in Cal. Rest. Ass'n v. City of Berkeley  
No. 21-16278am archived December 27, 2023*

## Section 10

### Electric Switchboards: 0 volts Through 600 volts

---

#### 10.1 Scope

This section of the manual provides specific dimensions and details for service and meter equipment that is assembled by the manufacturer in freestanding, self-supporting switchboards.

#### 10.2 General Requirements

Applicants must meet the following requirements when they plan to install electric switchboards.

- A. Ensure that switchboard service and meter equipment is built to the requirements of this section.
- B. Ensure that metering switchboard and panelboard drawings, with current ratings of 320 amperes (amps) or above, are submitted in triplicate to Pacific Gas and Electric Company (PG&E) for review and approval. Drawings must contain specific [Electric Utility Service Requirements Committee \(EUSC\)](#) or Electric and Gas Service Requirements (Greenbook) drawing and sheet numbers for reference purposes. Refer to [Section "Electric Metering: General," Subsection .2.2., "Drawing Submittal Requirements for Metering and Service Termination Equipment,"](#) on Page 1, for detailed requirements.
- C. Ensure that drawings submitted for PG&E's review and approval include the following information:
  - The contractor's name and address
  - The applicant's name
  - The job location
  - Phase, voltage, and ampacity rating
  - Energy Reduction Maintenance Switch (ERMS) and associated component's location
- D. Before authorizing the manufacture of a switchboard, an applicant must consult his or her local PG&E project coordinator for specific general utility requirements.

NOTE: See [Table FM-1, "Service Planning Office and Inspection Desk Contact Information,"](#) at the front of this manual starting on Page iv, for specific contact numbers listed by area.

## 10.2. (continued)

- E. General utility requirements include the following:
- horizontal bus-bar requirements
  - Service voltage, phase, and wires
  - Meter-panel requirements to determine the applicable rate schedule
  - Service-termination location
  - Switchboard and/or meter location(s)
  - Size and number of service conductors
- F. PG&E provides and installs meters, metering transformers, test switches, and all secondary wiring from the metering transformers to the meter.
- G. Applicants must ensure that separation exists between the meters and metering transformers for the following reasons.
- To ensure meter accessibility.
  - To prevent metering inaccuracies.
  - To prevent unacceptable environmental conditions.
- H. Applicants must ensure that rigid steel conduit is installed between the meter and the metering transformers. The rigid steel conduit must be 1-1/4 inches minimum diameter and must be limited to three 90° bends unless the applicant provides sealable, accessible, exposed conduits.
- I. Service-entrance conductors must enter the metering transformer compartment from one end and leave from the opposite end. The direction of the feed may be either from the top or from the bottom of the compartment.
- Load conductors must not reenter or pass through a current transformer (CT) compartment or any PG&E sealed compartment or section. Even if the conductors are inside of a raceway.
  - When transformer-rated meters are installed for multiple applicants, there must be a separate service section for each installed meter and its associated service switch.
  - When applicants install totalized metering, they must install, own, and maintain nominal 1-1/4-inch metal conduit between the switchboard metering facilities.
  - Applicants should group self-contained meters and switches only when they meet the following conditions.
    1. Do not run unmetered service entrance conductors and metered load conductors in the same conduit raceway or wiring gutter.
    2. Ensure that each meter position and each service switch or breaker is marked clearly and permanently and is identified by the building owner, or a representative of the building owner, to indicate the occupancy being served.

## 10.2. (continued)

- M. Ensure an Energy Reduction Maintenance Switch (ERMS) and its associated components are not installed in PG&E sections, when required to be installed. If components of the ERMS are installed in an unmetered bus location, they must be covered and barred off from the bus and a label (e.g., ERMS EC 2 0.8 ) must be affixed indicating the National Electric Code (NEC) rule number requiring the ERMS equipment.
- . See Subsection 10.8., “Adding New Metering Equipment to Existing Switchboards,” on Page 10- , before connecting a new meter panel or meter section to an existing switchboard.

## 10 Switchboard Service Section

A switchboard service section is the section of an applicant’s switchboard provided specifically for terminating the service conductors and for housing the metering transformers (if required), revenue meters, test facilities, and service switch or breaker.

## 10.1 Standard Switchboard Service Section

Applicants must ensure that:

- A. For all switchboard service sections with current ratings of 100 amps or above, the manufacturer submits drawings, in triplicate, to PG&E for approval. See Figure 10.1, “Pull Section,” on Page 10-2 , for more information.
- B. Switchboard drawings for all co-generation and self-generation installations are submitted to a local PG&E project coordinator for review and approval by the PG&E electric metering department before the switchboard is constructed or built. Ask your local project coordinator to submit them.

## 10.2 Specifically Engineered Switchboard Service Sections

A switchboard design that does not conform to the NEC standards is considered specially engineered. Typical examples are:

- Switchboards over 1,000 amps.
- Switchboards with service-breaker ratings too large for the standard switchboard service section.
- Multimeter service sections.

The general arrangement of the specially engineered switchboard service sections must follow, as nearly as possible, the requirements for standard switchboard service sections, as described in Subsection 10.1., “Standard Switchboard Service Section” (above), and the requirements described in Subsection 10. . ., “Requirements for All Switchboard Service Sections” (below).

## 10 Requirements for 115 Volt Switchboard Service Sections

This subsection describes the general requirements for all switchboard service sections and applies to all applicants.

- A. The general arrangement and spacing of CTs and the methods of mounting CTs must conform as closely as possible to the illustrations in Figure 10-2 through Figure 10-8 on Page 10-8 through Page 10-18.
- B. Mount the socket meters that are used with metering transformers on hinged panels. Mount the self-contained meters on nonhinged panels.
- C. When a hinged meter panel is located behind an enclosure door, leave a clear space of at least 11 inches between the meter panel and the door. That is the minimum space required to mount the meter.
- D. The meter panels must open at least 90° after the meters and test facilities are in place. If needed, applicants must increase the width of the section to meet these requirements.
- E. Applicants must provide a clear space in the back of a meter panel for the secondary wiring and associated equipment.
- F. For hinged meter panel doors, applicants must provide at least the minimum dimensions between the facility's meter panel and the nearest bus, as shown in Figure 10-2 through Figure 10-8 on Page 10-8 through Page 10-18.
- G. For nonhinged meter panel doors, applicants must provide a clear space of at least 18 inches to any barrier or obstruction.
  - . Applicants must ensure that the minimum clearance be maintained between meters as shown in Figure 10-1 , "Standard Section for Self-Contained Meter Sockets, 0 Amps–22 Amps, Installed in Switchboards: Nonresidential," on Page 10-2 , and Figure 10-1 , "Pull Section," on Page 10-2 .
- I. An applicant must maintain a minimum clear space of 18 inches directly below the bottom slot of the meter test switch. This space permits test leads to be connected safely.
  - . Applicants must not mount more than two self-contained meters on any removable meter panel.
  - . Applicants must ensure that panels providing access to metering transformers or a service-terminating pull section are no larger than 9 square feet in area. Removable panels must have two lifting handles.
  - . Applicants must ensure that the front edge of the CT bus bars are located in the same switchboard section, and in the same vertical plane.
- M. Applicants must use either one-bolt or four-bolt connections for switchboards that are rated 1,001 amps through 1,000 amps and have 1/2-inch buses installed. For switchboards with 3/4-inch buses, use either two-bolt or six-bolt connections.

## 10. . . (continued)

- . Applicants must ensure that buses are securely supported in the metering transformer compartment to withstand the mechanical stresses of a short circuit and to resist movement. The bus supports must not interfere when CTs either are installed or are removed. Do not use CTs to support the buses.
- O. Applicants should ensure that the buses and CT mountings are designed so that each of the CTs can be removed from its mounting position directly through the access panel without disturbing any other CT.
  - hen using multi-leaf buses, orient the buses so that they appear “edgewise” when viewed from the access panel.
- P. hen using an aluminum bus, applicants must ensure that the aluminum bus bar is plated to prevent corrosion.
  - . Applicants must ensure that all electric meter panels and all equipment doors or panels that are intended to provide access to potential transformers (PTs) and CTs are permanently marked or labeled to indicate the service voltage being supplied.
  - . In switchboards rated over 800 amps, applicants must ensure that the bus bars extend rom the termination section and service landing lugs into the CT compartment. In switchboards with multiple meters, the bus bars must extend from the termination section and service landing lugs to the meter sockets in multimeter boards.
- S. Switchboard manufacturers must provide accessories, such as additional Belleville washers, at the time of delivery and/or installation.
- T. Switchboards must meet all of the design and test conditions of Underwriters Laboratories (\_\_\_) 891, “Standard for Switchboards.”
  - . Applicants must ensure that bus arrangement and supports are provided. An exception is the neutral bus, which may be located on either sidewall.
  - . Applicants must locate the CT compartment on the supply side of the service-section main switch or breaker.
  - . Applicants must ensure that only metering conductors pass through this CT compartment.
  - . Applicants must ensure that a neutral, bus-bar extension is provided in the instrument transformer compartment above the lower CT bus support when the service-section phase buses are supplied from the horizontal cross busing.
  - . Applicants must ensure that the return flanges for the lower- and upper-meter panel supports do not project more than 1/2 inch up or down from the adjacent switchboard panels.
  - . Applicants must ensure that each bus has a connector that accepts a stranded conductor with the amp capacity of the service-section main switch or breaker.
- AA. Applicants must ensure that the power-leg bus for a 3-wire delta service is identified.

10. . . (continued)

- AB. Applicants must ensure that a removable link is installed in the right-side phase bus when using the service section for three-phase, -wire service.
- AC. Applicants must ensure that each switchboard service section is completely barriered from other service sections, pull sections, service switches, or disconnects. If possible, use barriers made of either steel or the same material as the section walls.

Barriers may have an opening to allow unmetred conductors to pass between sections. The barrier between sealed utility metering sections and the pull section must be 1/8 inch minimum. Glastic or other equivalent barrier is not preferred but may be acceptable. The clearance between the bus bar and barrier must be a maximum of inches. A barrier is not required between individual phases and the neutral. See Figure 10-1, "Switchboard Wall Opening Between Sections," on Page 10-6.

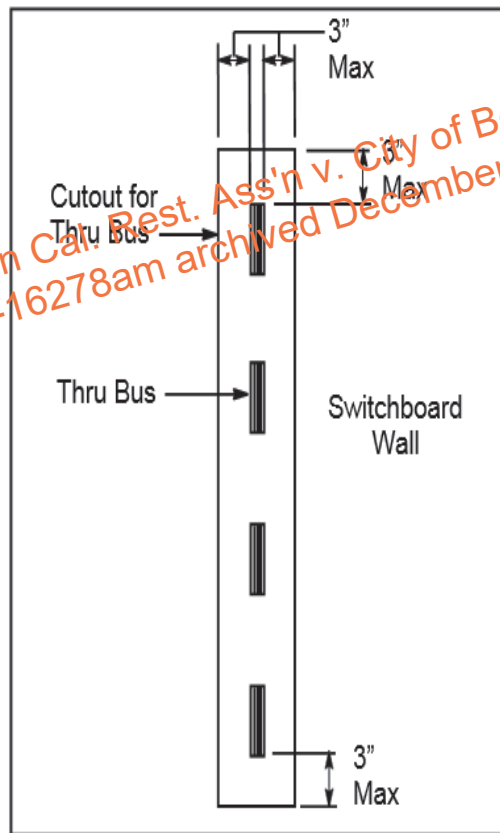


Figure 10-1  
Switchboard Wall Opening Between Sections

- 10 Standard Switchboard CT Compartment, 0 amps Through 1,200 amps, Single-Phase or Three-Phase, Air Service
- Applicants must ensure that the following requirements are met. These requirements apply specifically to this type of CT compartment.
- A. The bus dimensions are a minimum of 1/2 inch by 2 inches and a maximum of 3/4 inch by 2 inches.
  - B. The barrier must be constructed of insulating, nontracking material. Ensure that openings in the barrier and clearances to the outer edges do not exceed 1/8 inch. Use non-conductive fasteners to attach the barrier.
  - C. The minimum clearance between the meter panel or socket and the bus is 6 inches. If a clearance of 6 inches is not possible, use a 3/4-inch bus as required in Subsection 10.6., "Standard Switchboard CT Compartment, 1,001 Amps Through 1,000 Amps, Single-Phase or Three-Phase, Air Service," on Page 10-11.
  - D. A clear, unobstructed workspace is provided around the current transformer bus units as measured from the inside edge of the compartment access opening.

*cited in Cal. Rest. Ass'n v. City of Berkeley  
No. 21-16278am archived December 27, 2023*



10. . . (continued)

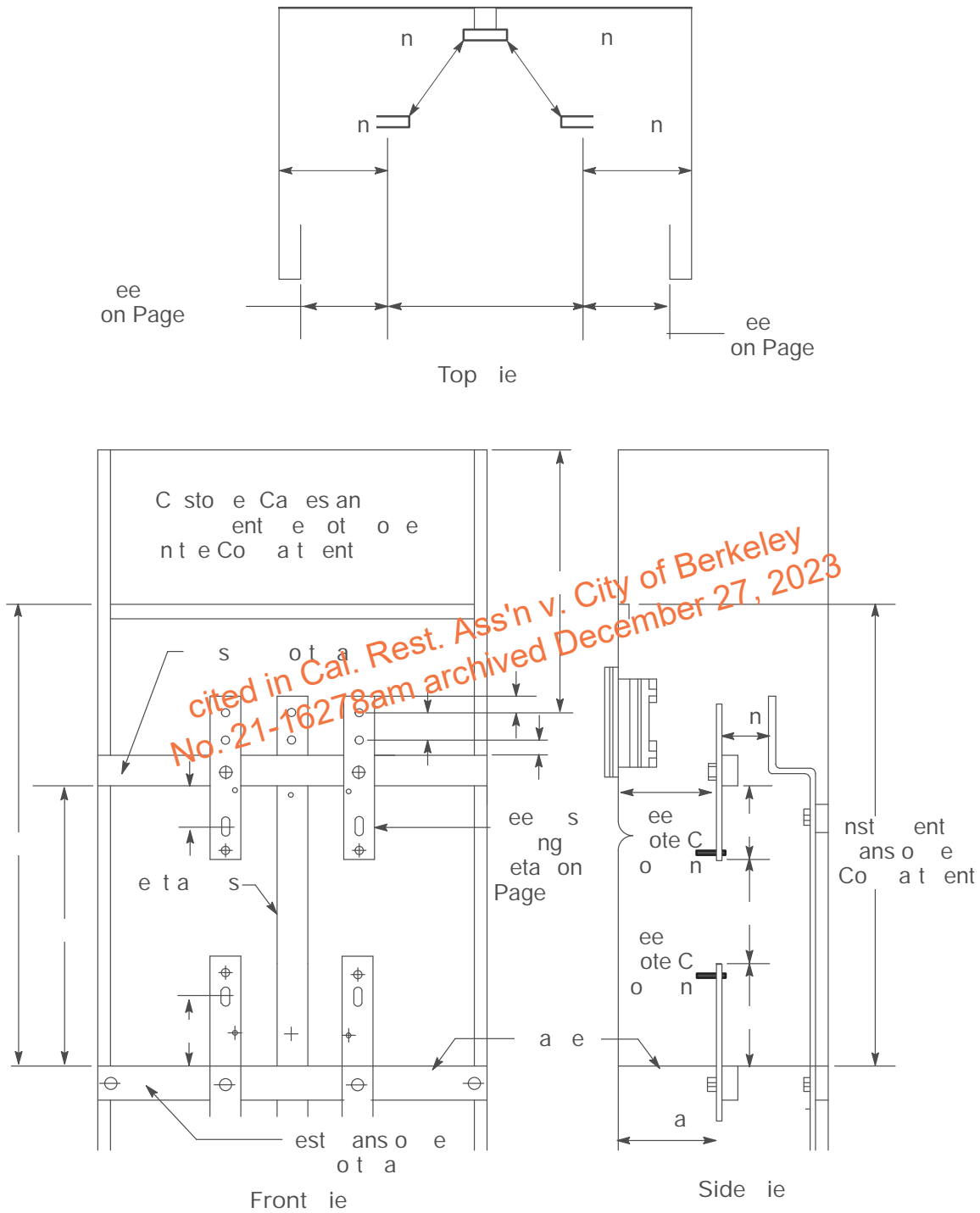


Figure 10-2  
Standard Switchboard, CT Compartment, 0 mps- 00 mps, Single Phase

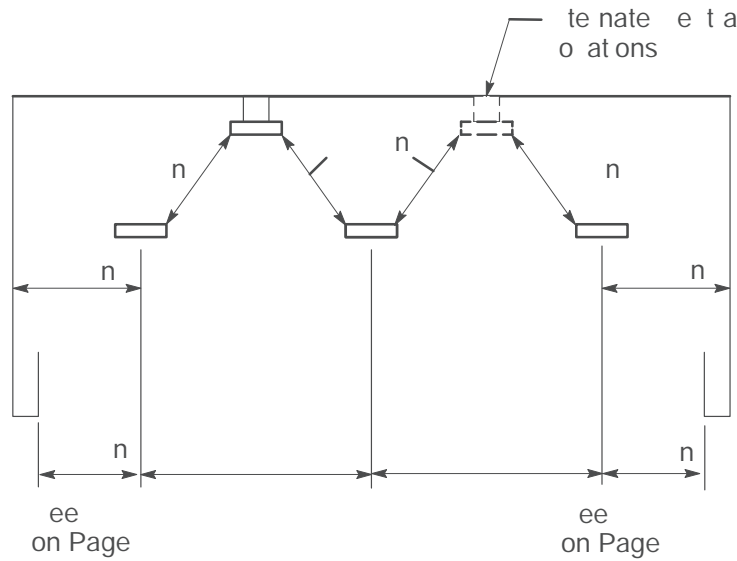
- 10 Standard Switchboard CT Compartment, 0 amps Through 1,200 amps, Three-Phase, Single-Line and Three-Line Services

Applicants must ensure that the following requirements are met. These requirements apply specifically to this type of CT compartment.

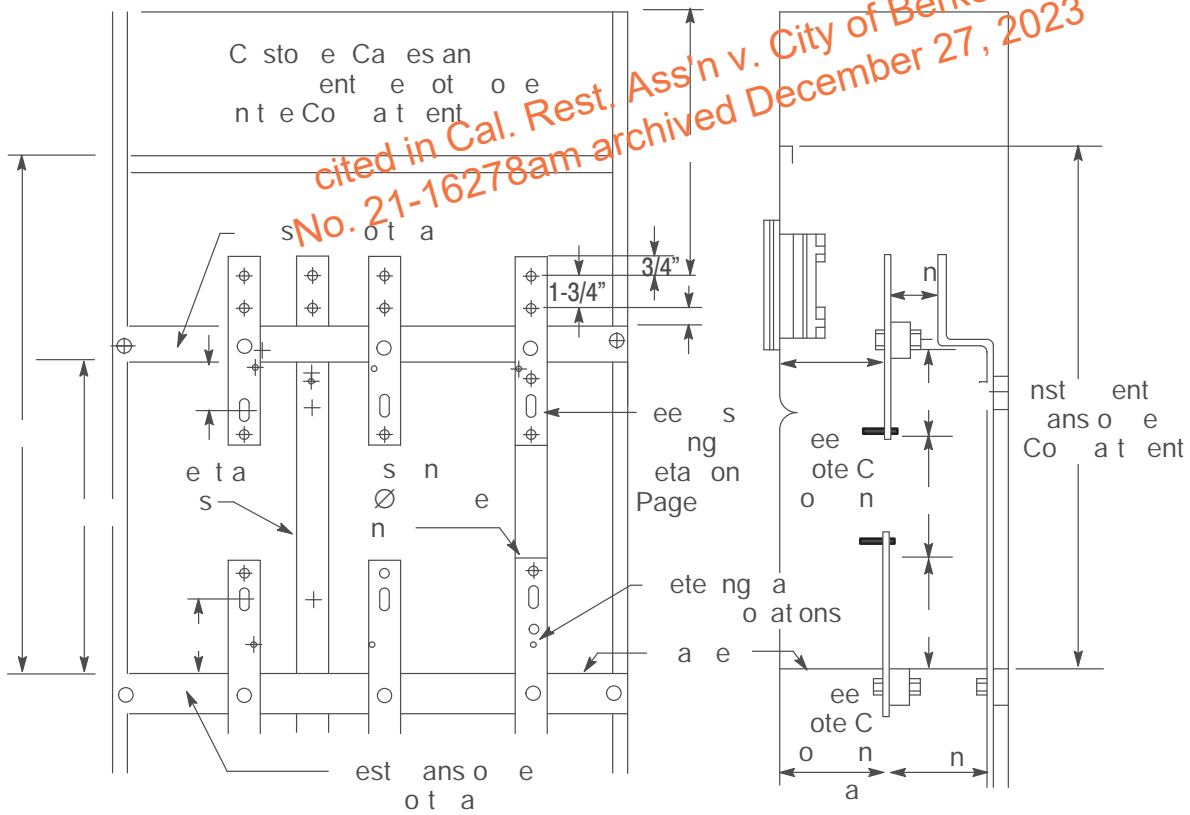
- A. Ensure that the bus dimensions are a minimum of 1 1/2 inch by 2 inches and a maximum of 2 1/2 inch by 2 inches.
- B. Ensure that the barrier is made of an insulating, nontracking material. Ensure that openings in the barrier and clearances to the outer edges do not exceed 1/8 inch. Use nonconductive fasteners to attach the barrier.
- C. The minimum clearance between the meter panel or socket and the bus is .0 inches up to 1,000 amps and .1 inches for amp compartments between 1,001 - 1,200 amps. If a clearance of .1 inches is not possible, use a 1/2-inch bus as required in Subsection 10.1.1 on Page 10-1 .
- D. A clear, unobstructed work space is provided around the current transformer bus units as measured from the inside edge of the compartment access opening.

*cited in Cal. Rest. Ass'n v. City of Berkeley  
No. 21-16278am archived December 27, 2023*

10. . . (continued)



Top ie



Front ie

Side ie

Figure 10-  
Standard Switchboard, CT Compartment, 0 1,000 volts  
and 1,001 1,200 volts, Three Phase

*cited in Cal. Rest. Ass'n v. City of Berkeley  
No. 21-16278am archived December 27, 2023*

## 10. . . (continued)

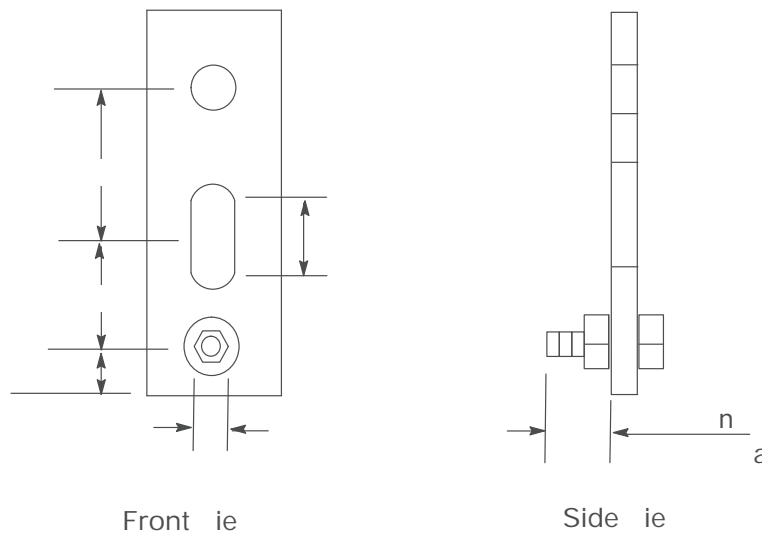


Figure 10-  
Bus Drilling Detail

10 Standard Switchboard CT Compartment, 1,001 Amps Through 10,000 Amps, Single-Phase or Three-Phase, - Wire Service

The following requirements specifically apply to the CT compartment shown in Figure 10-10, "Standard Switchboard, CT Compartment, 1,001 Amps – 10,000 Amps, Single-Phase or Three-Phase, - Wire Service," on Page 10-12. Applicants must:

- A. Ensure that the buses are anchored so that they will remain in position when the removable section is out.
- B. Ensure that the bus corners are rounded to prevent damaging the insulation.
- C. For underground services, ensure that the buses extend into the pull section.
- D. Be aware that the maximum permissible bus unit consists of four 1/2-inch by 1/2-inch bars spaced 1/2 inch apart.
- E. Ensure that the barrier is a minimum of 12 inches and a maximum of 20 inches above the standing surface.
- F. For a single-phase switchboard, ensure that the neutral bus is located at the side of the compartment.
- G. Ensure that the switchboard manufacturer secures the removable bus link to the upper- and lower-CT bus units using 1/2-inch hex-head (Grade 5) steel bolts with 2-1/2-inch diameter Belleville washer and nut.
- H. Ensure that openings in the barrier and clearances to the outer edges do not exceed 1/8 inch. Use nonconductive fasteners to attach the barrier.

10. .6. (continued)

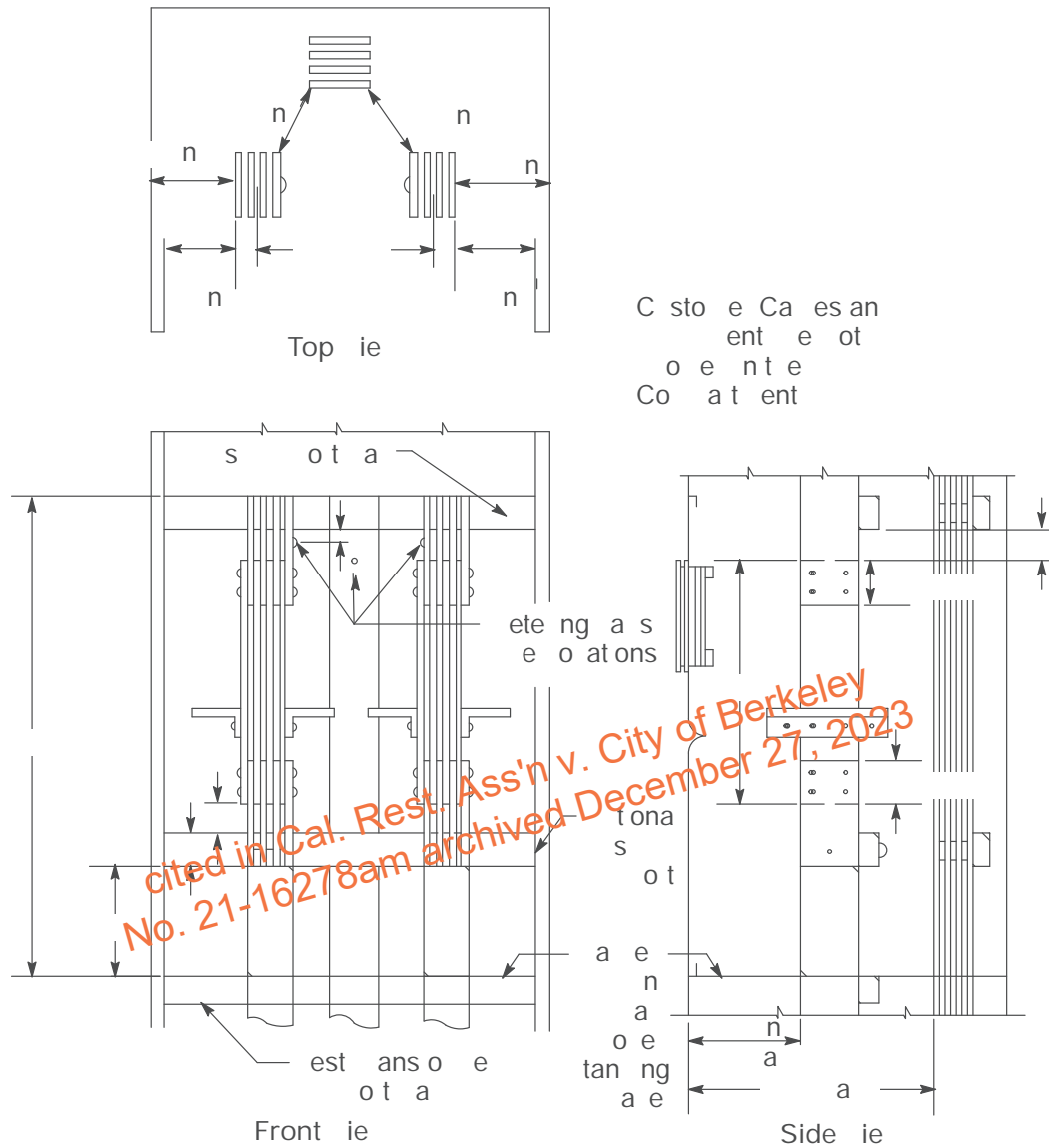


Figure 10-  
 Standard Switchboard, CT Compartment, 1,001 volts- 10,000 volts,  
 Single-Phase or Three-Phase, Air Service

- 10 7 Standard Switchboard, CT Compartment, 1,001 Amps Through 1,000 Amps, Three-Phase, Single Service

The following requirements specifically apply to the CT compartment shown in Figure 10-6, "Standard Switchboard, CT Compartment, 1,001 Amps– 1,000 Amps, Three-Phase, Single Service," on Page 10-1 . Applicants must:

- A. Ensure that the buses are anchored so that they will remain in position when the removable section is out.
- B. Ensure that the bus corners are rounded to prevent damaging the insulation.
- C. For underground services, ensure that the buses extend into the pull section.
- D. Be aware that the maximum permissible bus unit consists of four 1/2-inch by 1/2-inch bars spaced 1/2 inch apart.
- E. Ensure that the barrier is a minimum of 4 inches and a maximum of 60 inches above the standing surface.
- F. Ensure that the switchboard manufacturer secures the removable bus link to the upper- and lower-CT bus units using 1/2-inch hex-head (Grade 5) steel bolts with 2-1/2-inch diameter Belleville washers and nuts.
- G. Ensure that openings in the barrier and clearances to the outer edges do not exceed 1/8 inch. Use nonconductive fasteners to attach the barrier.

cited in Cal. Rest. Ass'n v. City of Berkeley  
No. 21-16278am archived December 27, 2023

10. . . (continued)

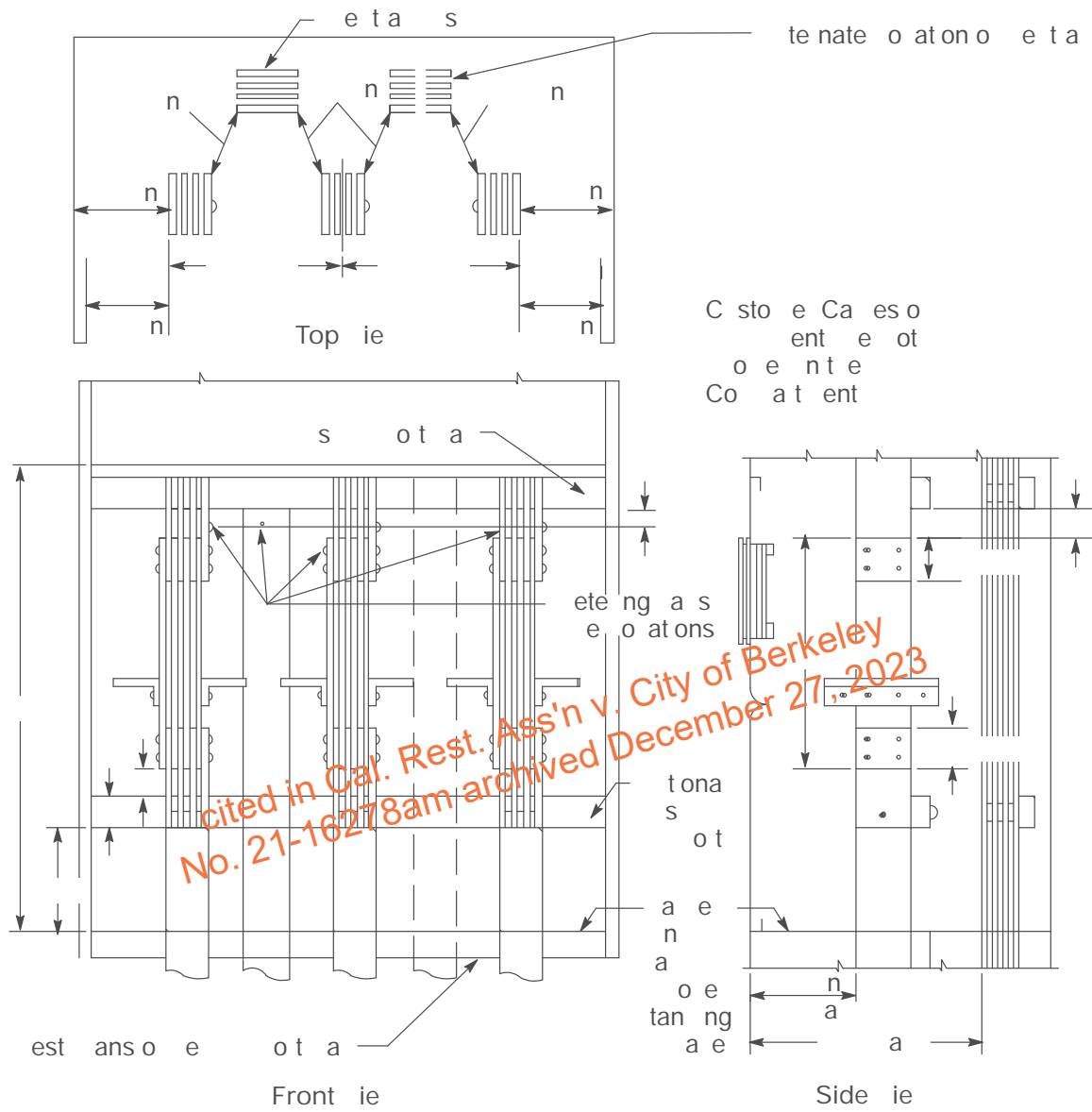


Figure 10- Standard Switchboard, CT Compartment, 1,001 mps- ,000 mps, Three-Phase, - Wire Service

- 10 Standard Switchboard CT Compartment, 1001 amps and larger, Three-Phase, Single Service

The following requirements specifically apply to the CT compartment shown in Figure 10-1, "Standard Switchboard, CT Compartment, 1001 Amps and larger, Three-Phase, Single Service," on Page 10-16.

Applicants must:

- A. Ensure that the buses are anchored so that they will remain in position when the removable section is out.
- B. Ensure that the bus corners are rounded to prevent damaging the insulation.
- C. For underground services, ensure that the buses extend into the pull section.
- D. Be aware that the maximum permissible bus unit consists of four 1/2-inch by 1/2-inch bars spaced 1/2 inch apart.
- E. Ensure that the barrier is a minimum of 4 inches and a maximum of 60 inches above the standing surface.
- F. Ensure that the switchboard manufacturer secures the removable bus link to the upper- and lower-CT bus units using 1/2-inch, hex-head (Grade 5) steel bolts with 2-1/2-inch diameter Belleville washers and nuts.
- G. Ensure that openings in the barrier and clearances to the outer edges do not exceed 1/8 inch. Use nonconductive fasteners to attach the barrier.

cited in Cal. Post. Ass'n v. City of Berkeley  
No. 21-16278am archived December 27, 2023



10. .8. (continued)

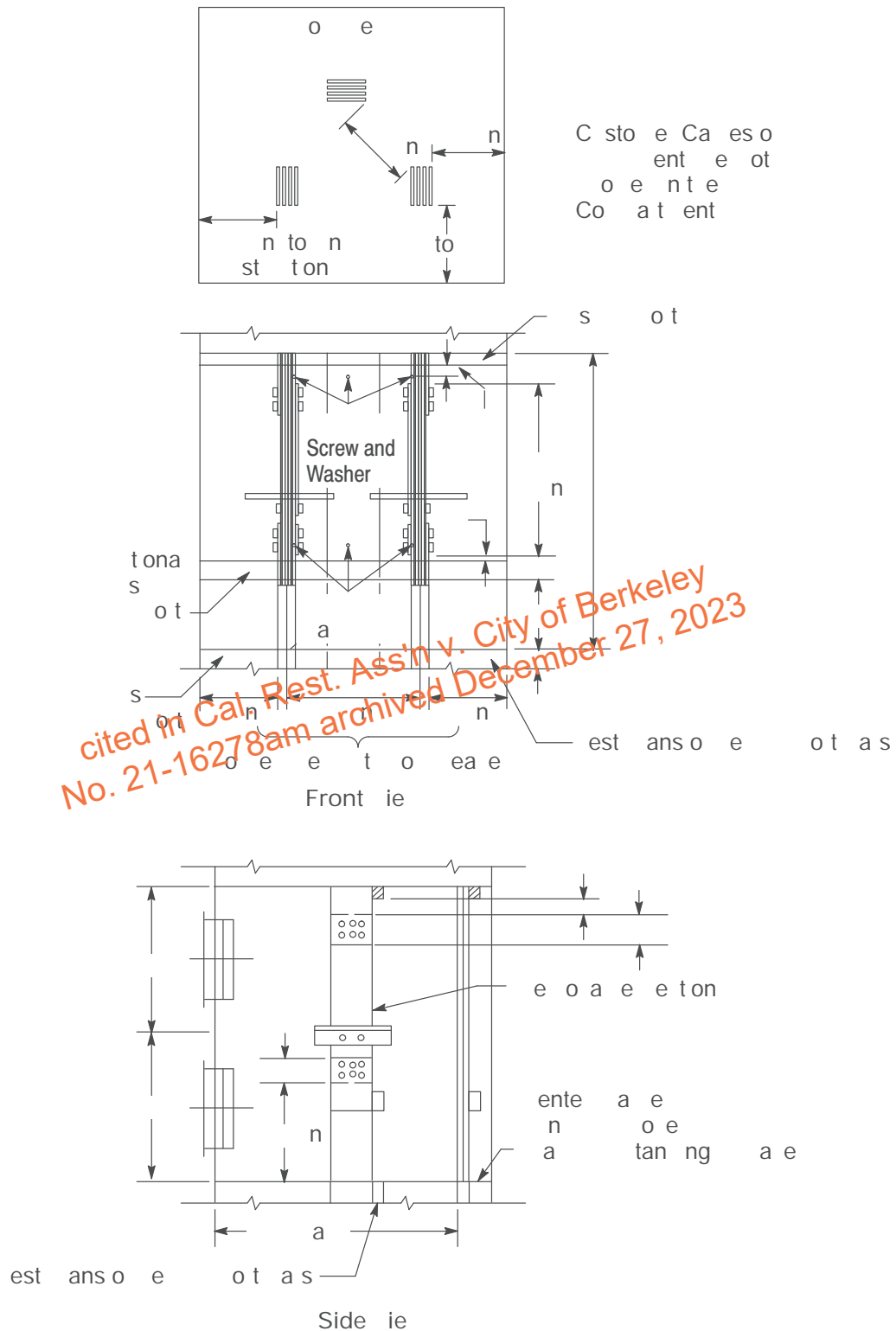


Figure 10-7  
Standard Switchboard, CT Compartment,  
,001 volts and larger, Three-Phase, Three-Wire Service

- 10 Standard Switchboard CT Compartment, 1001 amps and larger, Three-Phase, Single or Three-Phase Service

The following requirements specifically apply to the CT compartments shown in Figure 10-8, "Standard Switchboard, CT Compartment, 1001 Amps and larger, Three-Phase, Single or Three-Phase Service," on Page 10-18. Applicants must:

- A. Ensure that the buses are anchored so that they will remain in position when the removable section is out.
- B. Ensure that the bus corners are rounded to prevent damaging the insulation.
- C. For underground services, ensure that the buses extend into the pull section.
- D. Be aware that the maximum permissible bus unit consists of four 1/2-inch by 1/2-inch bars spaced 1/2 inch apart.
- E. Ensure that the barrier is a minimum of 4 inches and a maximum of 60 inches above the standing surface.
- F. Ensure that the switchboard manufacturer secures the removable bus link to the upper- and lower-CT bus units using 1/2-inch hex-head (Grade 5) steel bolts with 2-1/2 inch diameter Belleville washers and nuts.

*cited in Cal. Rest. Ass'n v. City of Berkeley  
No. 21-16278am archived December 27, 2023*

10. .9. (continued)

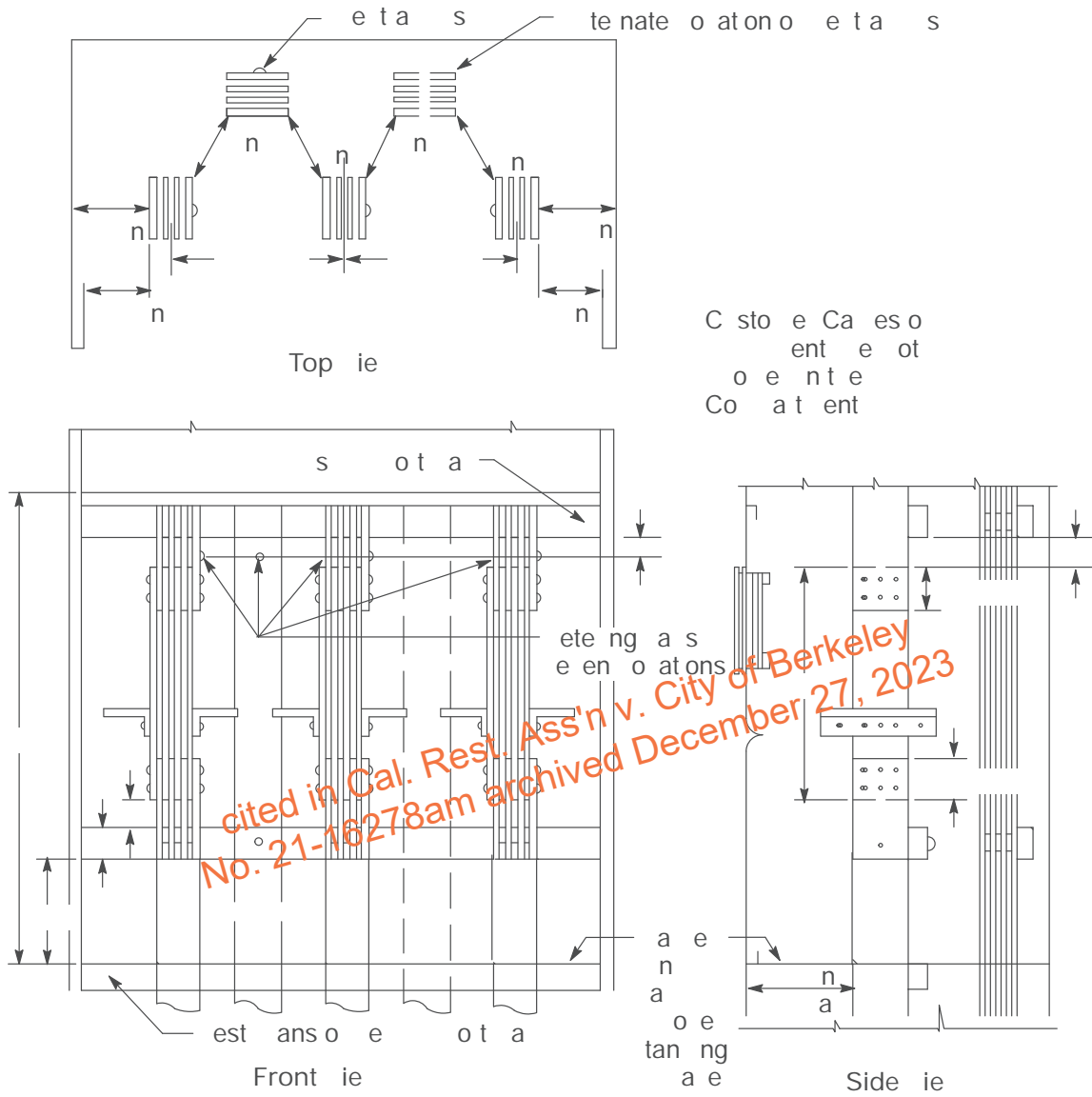


Figure 10- Standard Switchboard, CT Compartment, 1001 amps and larger, Three-Phase, Single-Phase or Three-Phase Service

## 10 10 Removable link assemblies

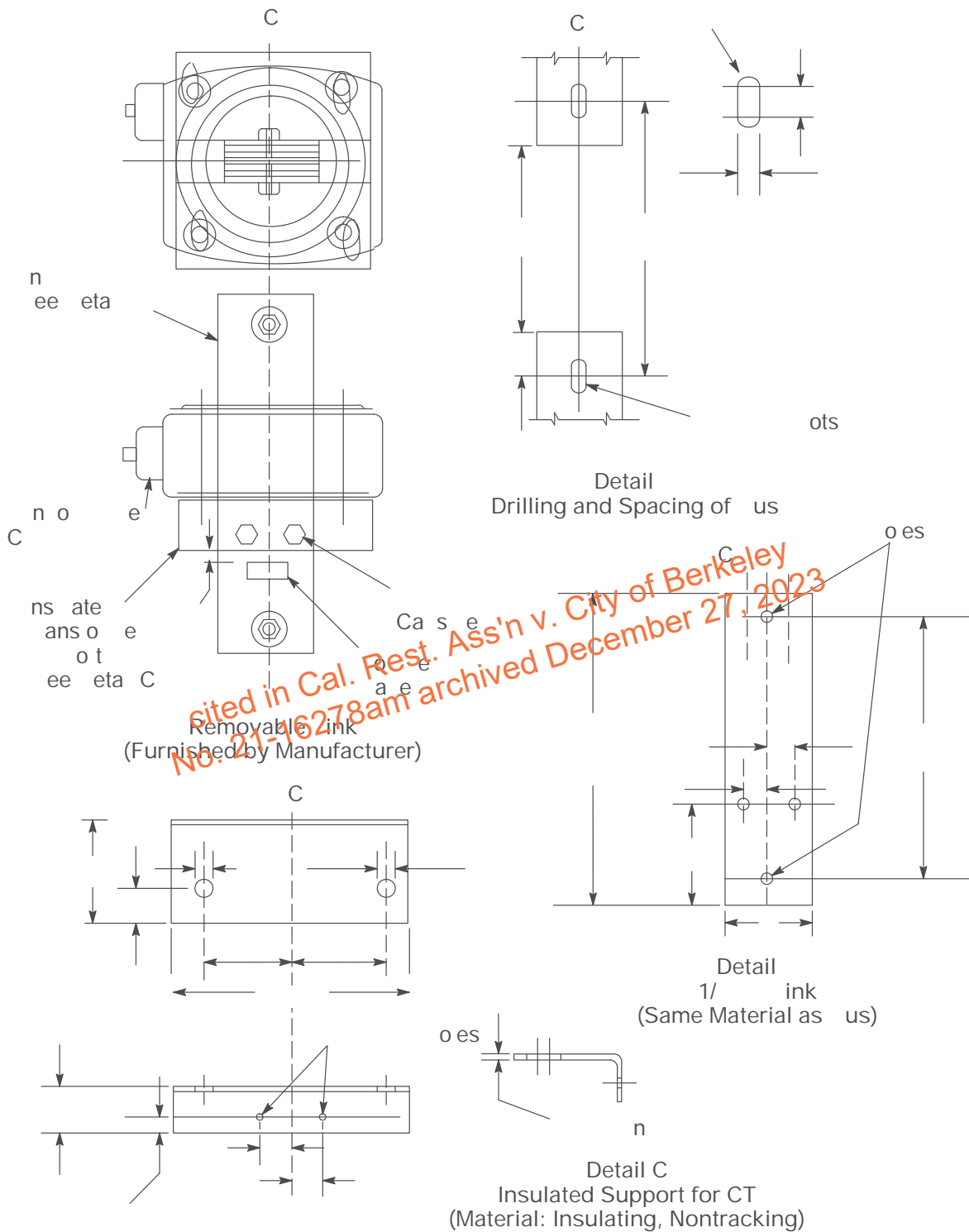
The removable link assemblies for 0-volt through 600-volt CT compartments from 1,001 amps through 1,000 amps, and 1,001 amps and larger, are shown in Figure 10-9 through Figure 10-12 on Page 10-20 through Page 10-21.

Applicants may use either a one-bolt connection, as shown in Figure 10-9, “Switchboards, 0 volts–600 volts, CT Compartment, 1,001 Amps– 1,000 Amps, Removable Link and CT Support (One-Bolt Configuration),” on Page 10-20, or a four-bolt connection, as shown in Figure 10-10, “Switchboards, 0 volts–600 volts, CT Compartment, 1,001 Amps– 1,000 Amps, Removable Link and CT Support (Four-Bolt Configuration),” on Page 10-21, for switchboards that are rated 1,001 amps to 1,000 amps and have 1/2-inch buses installed.

For switchboards with 3/4-inch buses, use either two bolts, as shown in Figure 10-11, “Switchboards, 0 volts–600 volts, CT Compartment, 1,001 Amps and larger, Removable Link and CT Support (Two-Bolt Configuration),” on Page 10-22, or six bolts, as shown in Figure 10-12, “Switchboards, 0 volts–600 volts, CT Compartment, 1,001 Amps and larger, Removable Link and CT Support (Six-Bolt Configuration),” on Page 10-21.

*cited in Cal. Rest. Ass'n v. City of Berkeley  
No. 21-16278am archived December 27, 2023*

10. .10. (continued)



Sited in Cal. Rest. Ass'n v. City of Berkeley No. 21-16278am archived December 27, 2023

Figure 10- Switchboards, 0 volts- 600 volts, CT Compartment, 1,001 mps- 1,000 mps, Removable Link and CT Support (One-volt Configuration)

10. .10. (continued)

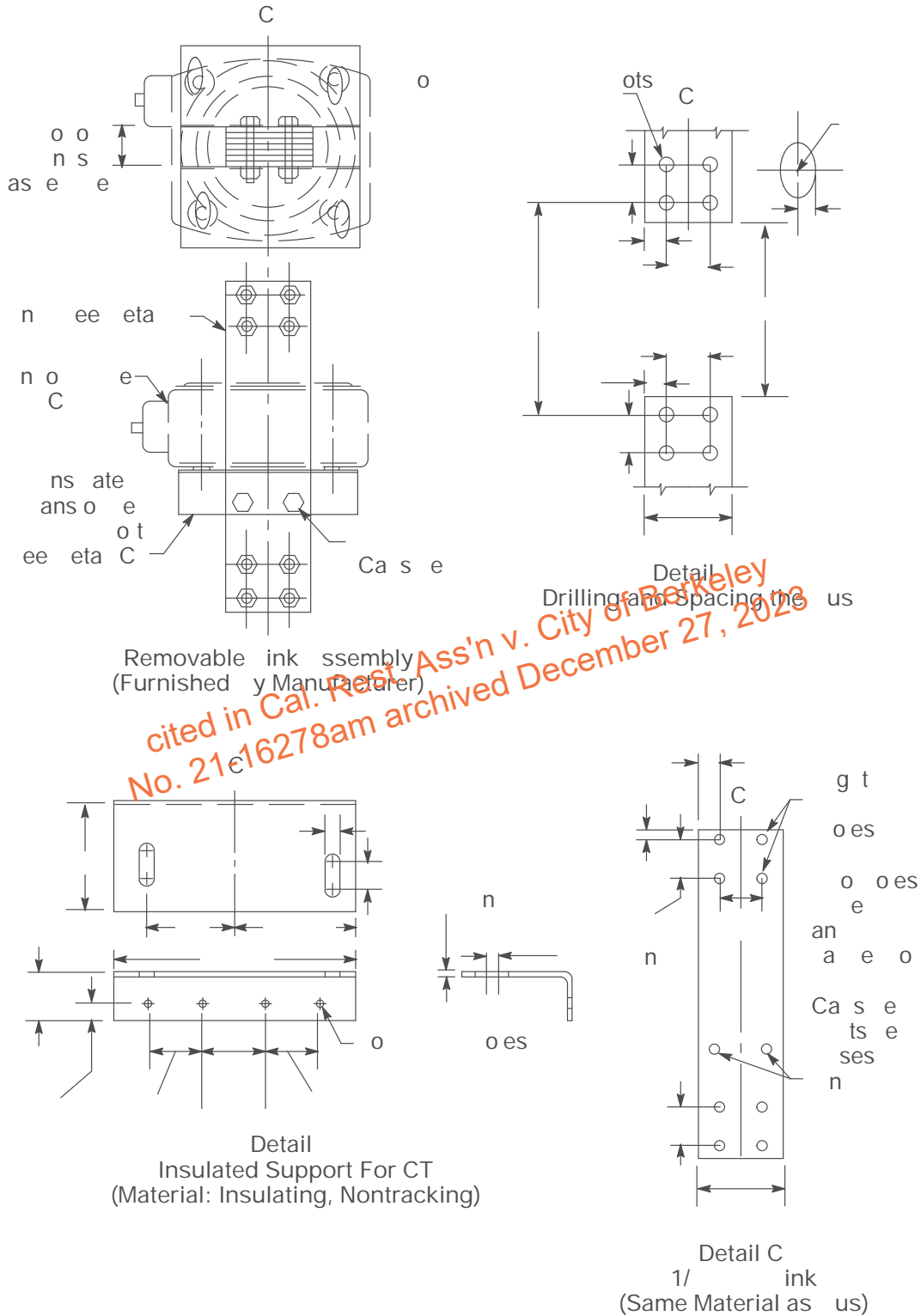
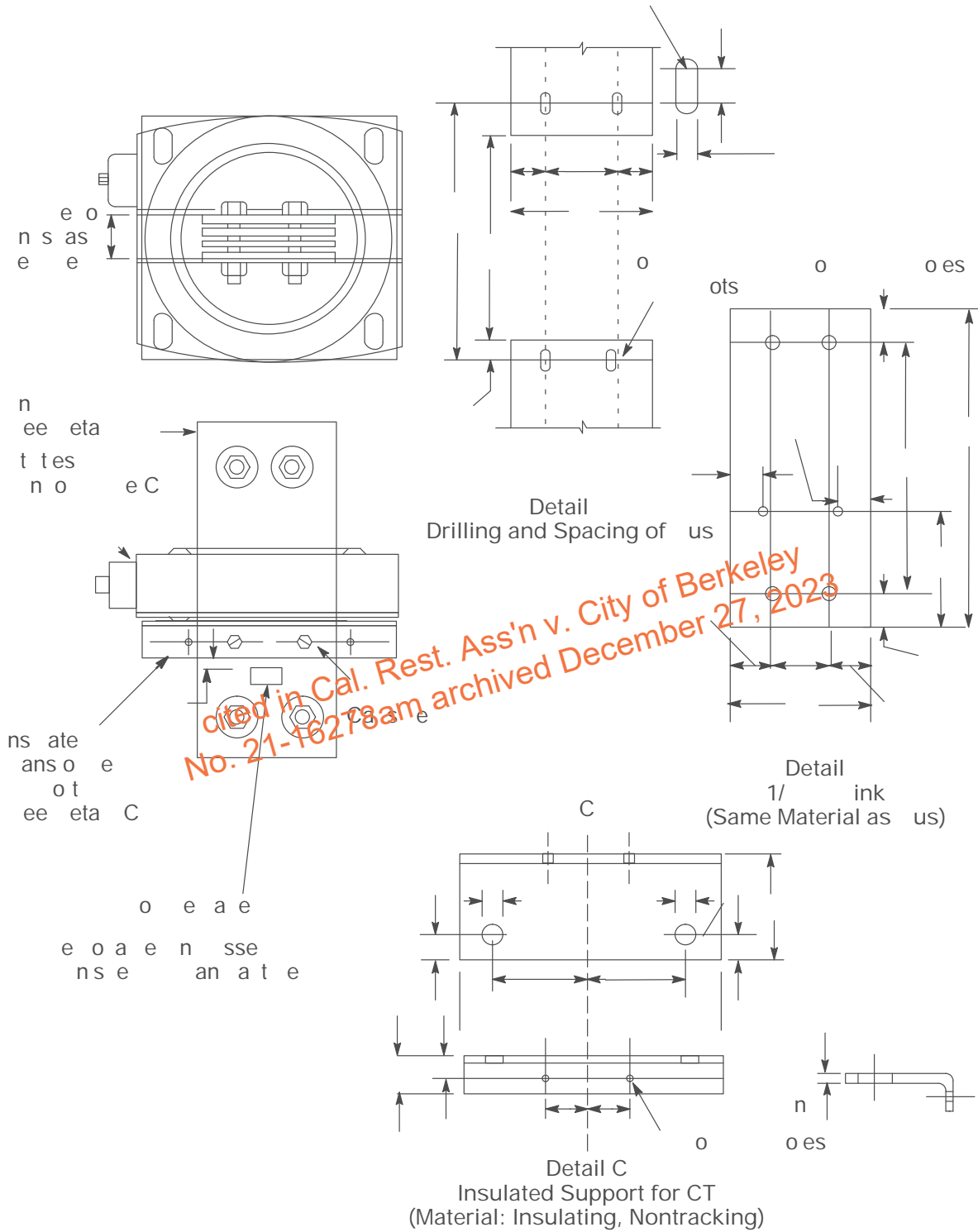


Figure 10-10

Switchboards, 0 olts- 00 olts, CT Compartment, 1,001 mps- ,000 mps, Removable ink and CT Support (Four-olt Configuration)

10. .10. (continued)



*Noted in Cal. Rest. Ass'n v. City of Berkeley No. 21-16278am archived December 27, 2023*

Figure 10-11  
Switchboards, 0 volts– 600 volts, CT Compartment,  
1001 mm and larger, Removable Insulator and CT Support (Top-olt Configuration)

10. .10. (continued)

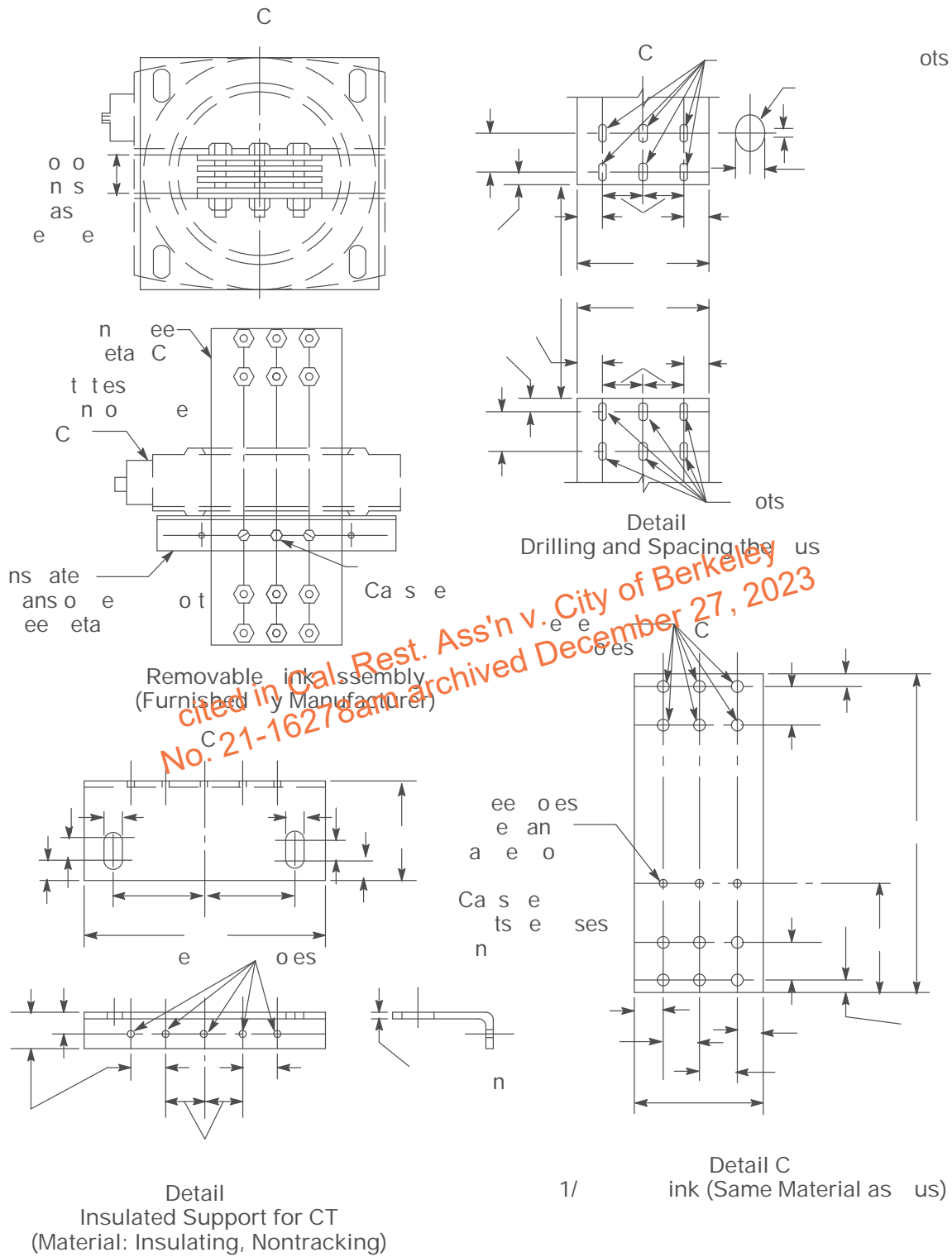


Figure 10-12  
Switchboards, 0 olts- 00 olts, CT Compartment,  
001 mps and arger, Removable ink and CT Support (Si - olt Configuration)



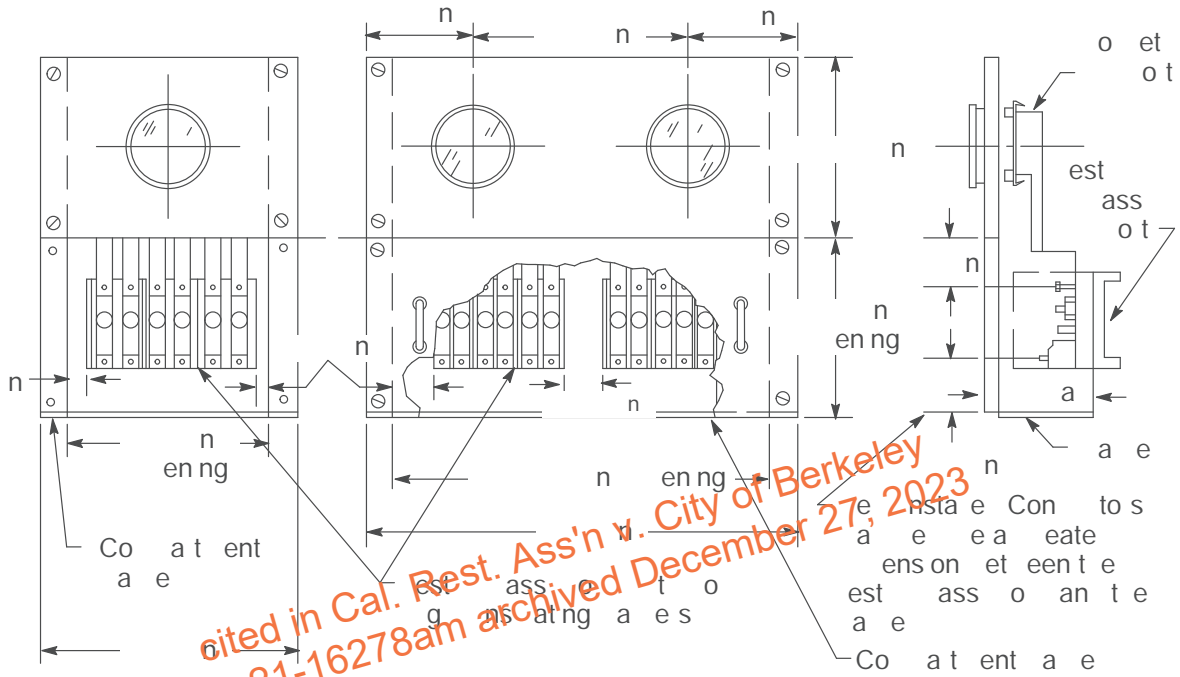
10 11 Standard Section for Self-Contained Meter Sockets, 0 volts Through 220 volts, Installed in Switchboards: Nonresidential

These requirements apply specifically to switchboard service sections for nonresidential, 0-amp through 220-amp meter sockets. Applicants must:

- A. Ensure that the manufacturer furnishes, installs, and wires or buses the test-bypass blocks to the meter socket with four, rigid, insulating barriers. Test blocks must conform to the requirements described in [Section 9, "Electric Metering Components."](#)
- B. Ensure that the metered conductors do not pass through the adjacent metering compartments, except in enclosed wireways.
- C. Ensure that the meter panels are removable with a maximum of two meters per panel.
- D. Ensure that the cover panels for the test-bypass block are sealable and fitted with handles. Panels more than 16 inches wide must have two handles.
- E. Ensure that outdoor or rain-tight enclosures are used, as shown in Figure 10- 1 through Figure 10- 2, "Outdoor or Rain-Tight Enclosures for Switchboards," on Page 10- 3.
- F. When a neutral is required for metering or testing, ensure that an insulated neutral terminal is provided behind each test-bypass cover panel. The terminal must be readily accessible when the cover panel is removed and must be individually connected to the neutral bus with a minimum size 8 American wire gauge (AWG) copper wire.
- G. Ensure that factory-installed, full-width, insulating barriers are located at the bottom of each test-bypass compartment. The insulating barrier must deflect a 1/2-inch maximum from a 20-pound downward force.
  - . For three-phase, 4-wire service, ensure that the seventh jaw is connected to the body of the neutral lug with an AWG 12 copper wire.
  - I. For three-phase, 4-wire, delta-connected service, ensure that the right-hand, test-bypass block (i.e., two poles) is identified as a power leg.
    - . For three-phase, 4-wire service, ensure that the bus is installed to connect the line and load poles together at the top of the center test-bypass block and the fifth jaw is connected to this bus using an AWG 12 copper wire.
    - . For single-phase, 3-wire service, ensure that the center test-bypass block is omitted.
    - . For single-phase, 3-wire, 120/208-volt service, ensure that the center test-bypass block is omitted and the fifth jaw is connected to the body of the neutral lug with an AWG 12 copper wire.
- M. Ensure that the meter panels are removable. However, they must not be removable when the meter is in place. Ensure that the meter socket is attached to the meter panel, and yet is supported independently from the meter panel.

10. .11. (continued)

- . Ensure that each line and load position is identified clearly by using 1/2-inch (minimum) block-letter labeling.
- O. Ensure that all of the meter panels are sealable and all of the securing screws are captive.



*cited in Cal. Rest. Ass'n v. City of Berkeley  
No. 21-16278am archived December 27, 2023*

Figure 10-1  
Standard Section for Self-Contained Meter Sockets,  
0 mps-22 mps, Installed in S itchboards: Nonresidential

## 10 12 Service Terminations for Underground Services

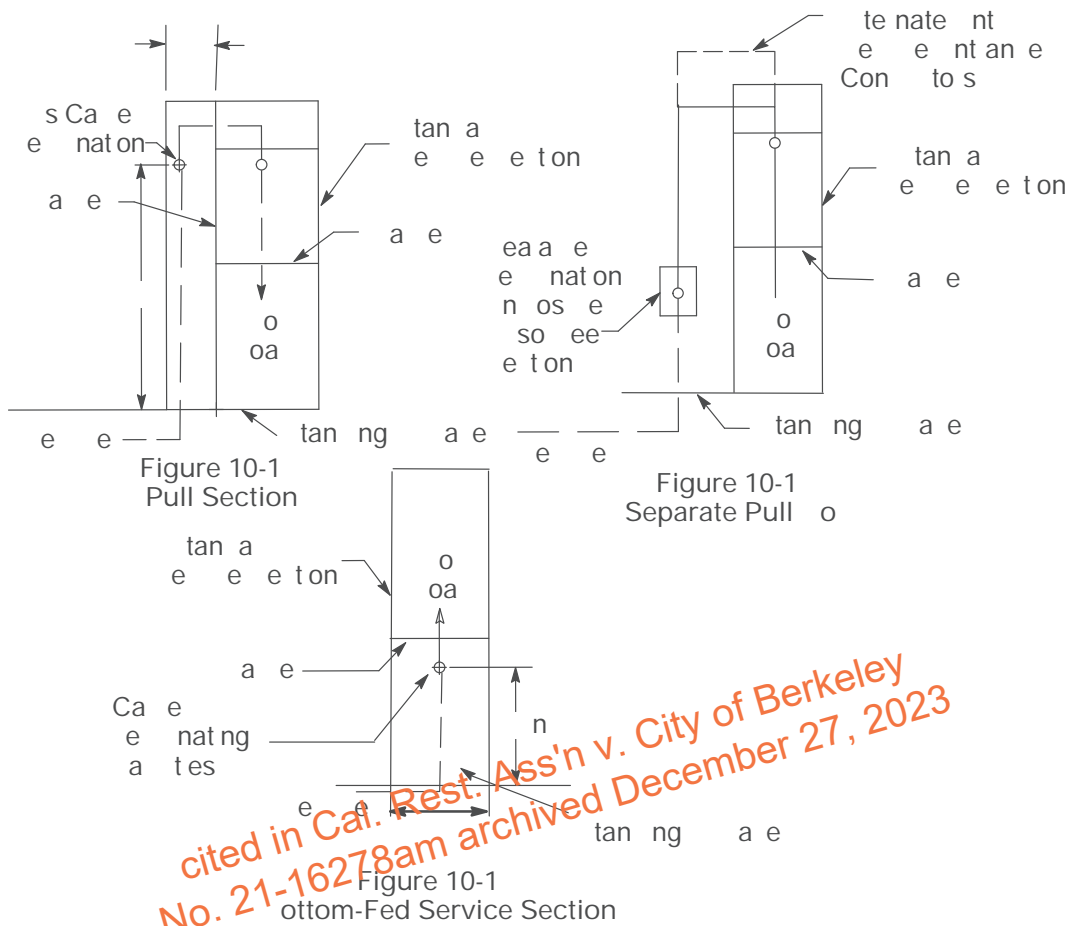
**NOTE:** For overhead services where conductors go into the bottom-fed termination section, the applicant must connect the service-entrance conductors to the line side of the bus stubs in the metering-transformer compartment.

PG&E pulls and terminates its service conductors when terminating facilities that are provided by the applicant as shown in Figure 10-1 , “Pull Section,” Figure 10-1 , “Separate Pull Box,” and Figure 10-16, “Bottom-Fed Service Section,” all on Page 10-2 . The requirements for pulling and terminating service are provided in the following paragraphs.

**Applicants must:**

- A. When the service section is served from a pull section, ensure that the bus or cable conductors enter in one of the following two ways:
  1. Enter through the side or back in the sealable section above the CT compartment, as shown in Figure 10-1 on Page 10-2 .
  2. Enter by means of horizontal cross-busing in back of the metering compartment.
- B. Ensure that all pull and terminating sections provide full-front access.
- C. Ensure that all of the cover panels for the pull section have all of the following attributes:
  - Are removable and sealable.
  - Have two lifting handles.
  - Are limited to a maximum size of 9 square feet in area.
- D. Ensure that the power leg for a 3-wire delta service is identified effectively at the point of termination before making the service connection.
- E. Ensure that the minimum width of the pull section has the dimensions specified in Table 10-1, “Minimum Bottom-Fed Pull-Section Dimensions,” on Page 10-2 .

10.12. (continued)



The minimum width of the pull section must meet the requirements specified in Table 10-1, below.

Table 10-1 Minimum Pull-Section Dimensions

Switchboard Rating (amps)	Minimum Access Opening Dimension (inches) <sup>2</sup>		Termination Height
	Minimum	Maximum	
0	Consult Serving Agency (All Measurements in Inches)		
-			n - a
-			
-			n - a
-	s t		

ee g e otto e e e e ton a o e o t e n te nat on eg to a  
 otto e se e se ton  
 te an ng st s n t e te nat on sa en sta e e en a to te a o t e oa  
 P e e e e n os e en s on s to e e to a o o a t e e a e n sta at on

10 1 Underground, Service-Termination Pull Section (located below Ground level)

Applicants must follow the requirements in this subsection when underground, service-termination pull sections are located below the ground level.

- A. Back Entry: When a service must enter the back of a switchboard pull section, as shown in Figure 10-1, "Switchboard Pull Section, High Entry," located on Page 10-0, the pull space must have the required dimension above or below the cable-terminating facilities. The pull sections must also have the required dimension, as shown in Table 10-2, "Pull Section Dimensions (Minimums) Below Ground level," located on Page 10-1.
- B. Side Entry: When a service must enter the side of a switchboard pull section, as shown in Figure 10-1 on Page 10-0, and in Figure 10-18, "Switchboard Pull Section, Low Entry," on Page 10-0, the pull-space must have the required dimension above or below the cable-terminating facilities. The pull sections must also have the required dimension, as shown in Table 10-2.
- C. Additional or Extended Section Entry: When it is not possible to meet the requirements of dimension because the service cannot enter the upper or lower areas of the switchboard pull section, or because additional space is needed, another enclosure can be attached to the termination section enclosure.

The following three figures show how another enclosure provides additional space for the cables to enter the termination section either low enough or high enough to meet the dimension and facilitate proper cable termination.

- Figure 10-19, "Extended Top on Switchboard Pull Section," on Page 10-1
- Figure 10-20, "Additional Side or Back Switchboard Pull Section High Entry," on Page 10-2
- Figure 10-21, "Additional Side or Back Switchboard Pull Section Low Entry," on Page 10-

PG&E recommends that applicants submit drawings for review before installing an additional enclosure. Applicants also should attend a pre-inspection meeting.

- D. Conduit: Service conduit installed in the franchise area (i.e., public property) must not be at a depth greater than 60 inches. Conduit entering the switchboard must be grouped together in a maximum of two rows and centered horizontally between the pull-section side walls. Refer to Figure 10-22, "Arranging Conduit in the Termination or Additional Pull Section (Front View, Back Entry, Example)" on Page 10-.

## 10. .1 . (continued)

- E. **Dimension:** The dimension is the measured distance between the first bolt on the termination bus to the closest service conduit installed in the pull section for Figure 10-1 on Page 10- 0 through Figure 10-19 on Page 10- 1. When an additional pull section is used, as shown in Figure 10-20 on Page 10- 2 and Figure 10-21 on Page 10- , the dimension is measured between the first bolt on the termination bus to the closest position where the service cable will enter into the termination section.
- F. **Water Drainage System:** To prevent water from accumulating in meter rooms (or other types of wet facilities), applicants must ensure the following actions are performed:
1. Design and construct the electrical meter room to discharge any water that may enter the switchboard and below-grade electrical meter room.
  2. Contact PG&E before construction begins to ensure the method(s) for discharging and removing water are approved.
- G. **Cable Support Hanger:** The cable hanger provides support for the cables and increases the cable height above the conductors. This creates a drip loop feature that stops water from dripping onto any exposed, live energized parts. The cable hanger must be structurally strong enough to support the weight of the type (i.e., aluminum Al or copper Cu ) and the maximum number of cables that could be installed for all phases. For large switchboards this could be up to 28 copper cables, mostly sized at 1,000 thousand circular mils (kcmil), with a total weight of about 1,000 pounds. Refer to Table in [umbered Document 06 928, "Methods and equirements for Installing on- esidential nderground Electric Services 0–600 olts to Customer-Owned Facilities."](#)
- Also, if the cables rest on or touch the support hanger, it must be made from, or wrapped in, a nonconductive material rated for a minimum 600 volts that provides electrical insulation and physical protection for the cables.

10.1.1 (continued)

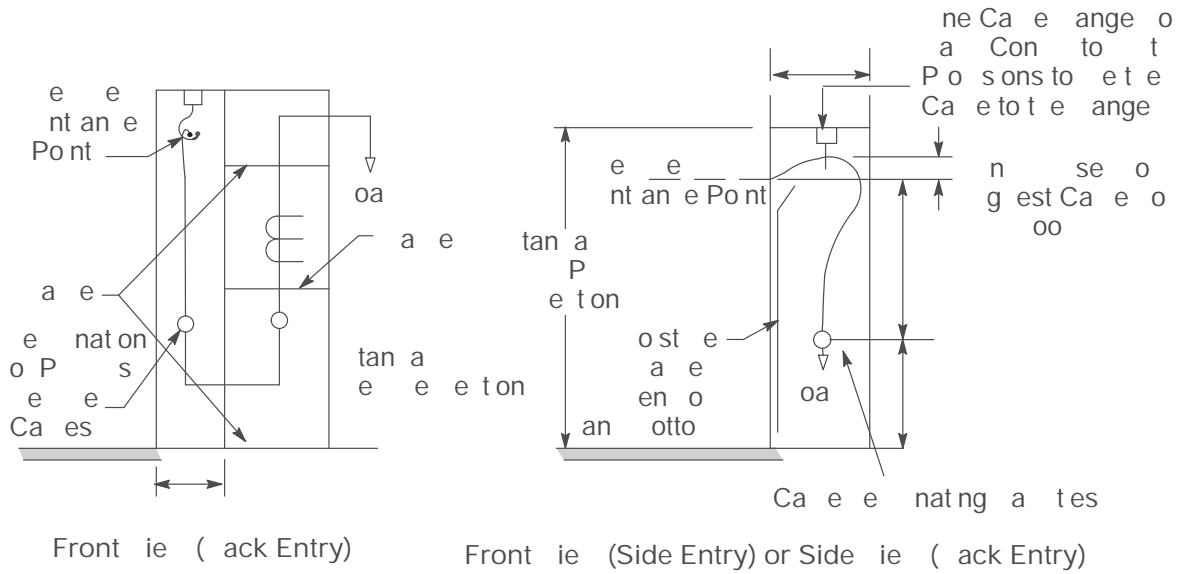


Figure 10-17  
Switchboard Pull Section - High Entry

*cited in Cal. Rest. Ass'n v. City of Berkeley  
No. 21-16278am archived December 27, 2023*

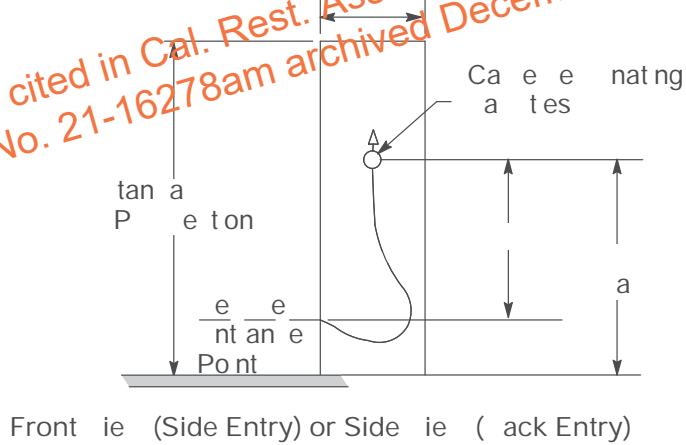


Figure 10-1  
Switchboard Pull Section - Low Entry

10.1.1 (continued)

Table 10-2 Pull-Section Dimensions (Minimums) above Ground level

Switchboard Rating in Volts	1, 2		Side or Back Entry	Termination Height
	1Ø - Wire	Ø - Wire		
	Measurements in Inches			
-				
-				
-				
-				
-	Notes			

Notes:  
 1. Minimum dimensions are shown. Larger dimensions may be required for specific applications.  
 2. Dimensions are in inches unless otherwise noted.  
 3. See Section 10.1.2 for additional information.

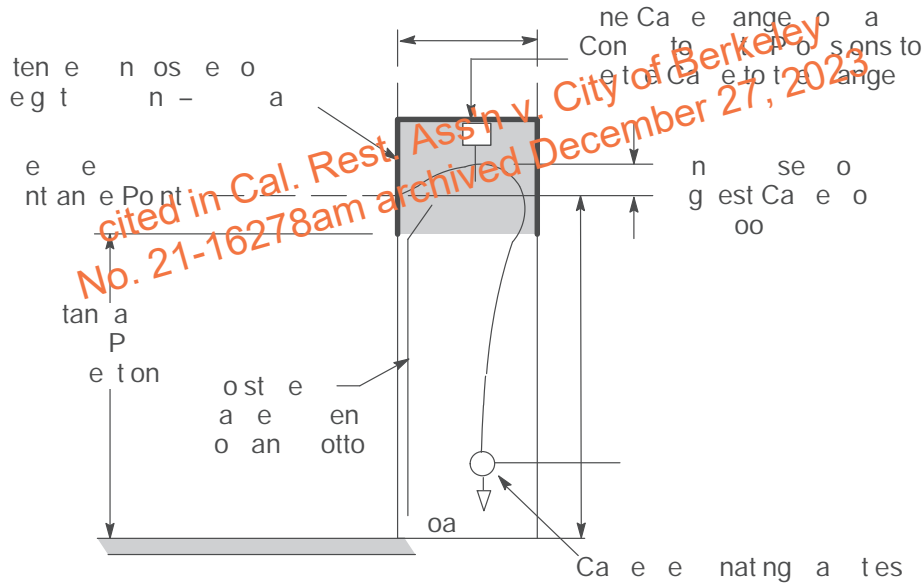


Figure 10-1  
 Extended Top on Switchboard Pull Section  
 Front View (Side Entry) or Side View (Back Entry)



10. .1 . (continued)

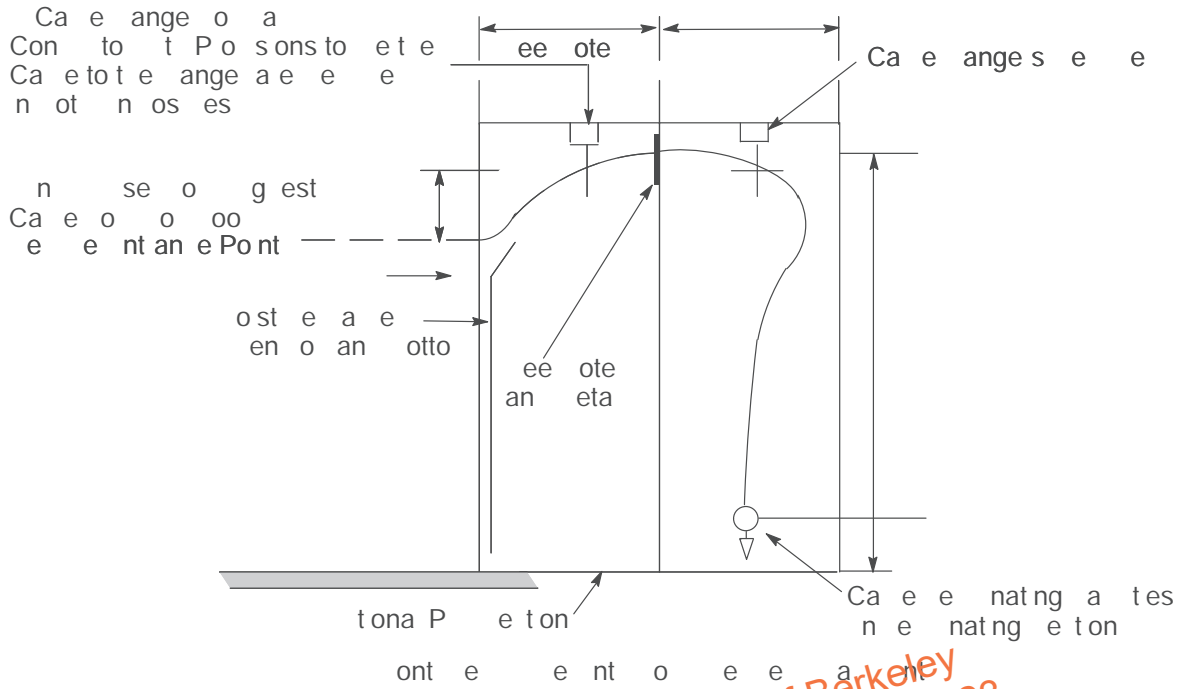


Figure 10-20  
Additional Side or Rack Switchboard Pull Section High Entry

Notes in reference to Figure 10-20:

1. Ensure that the dimensions (i.e., width, depth, and height) of the additional pull section are exactly the same as the terminating section.
2. The height of the cable entrance window must be between 2 inches to 6 inches and the width must be a minimum of 20 inches. The edges of the window opening must be insulated to prevent damaging the cables. See Detail A on Page 1.

10.1.1 (continued)

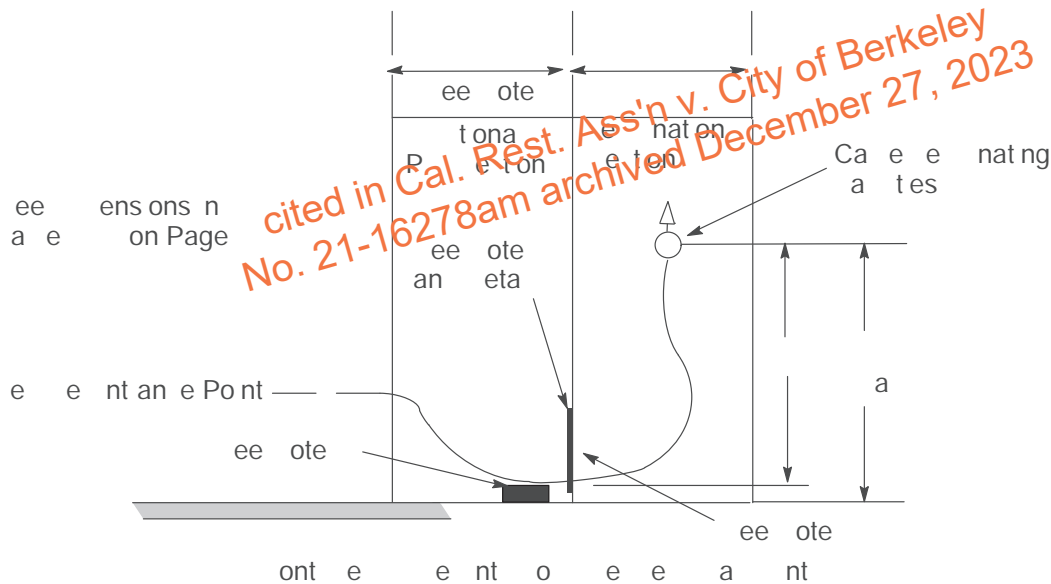
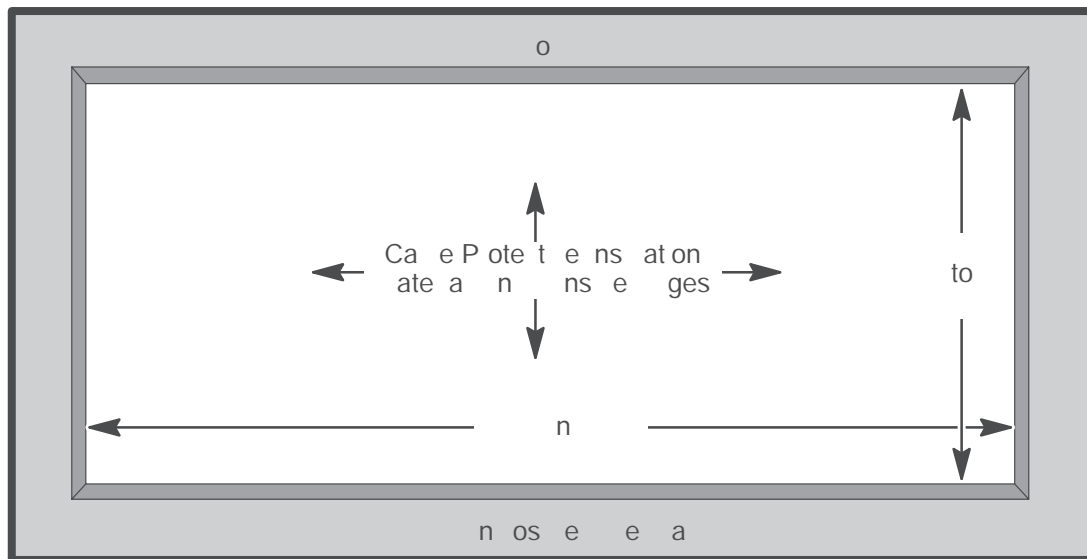


Figure 10-21  
Additional Side or Back Switchboard Pull Section Entry

Notes in reference to Figure 10-21.

1. Ensure that the dimensions (i.e., width, depth, and height) of the additional pull section are exactly the same as the terminating section.
  2. The height of the cable entrance window above the top of the pad is 18 inches maximum. Ensure that the window size is between 24 inches to 30 inches tall and the width is a minimum of 18 inches. Insulate the edges of the window opening to prevent damage to the cables. See Detail A above.
- . Cables must not lie on the ground. The applicant must provide a cable support system to keep the cables off the ground. Otherwise, the applicant must supply cable blocks using PG&E Material Code 62118.

10.1.1 (continued)

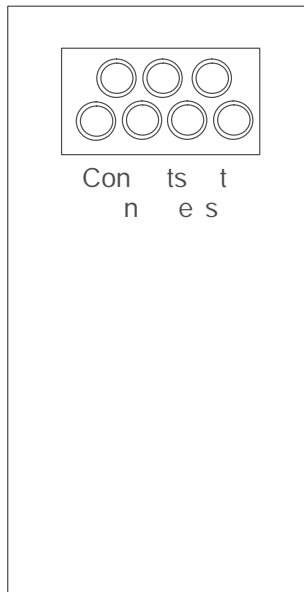


Figure 10-22 Arranging Conduit in the Termination or Additional Pull Section (Example of a Front Entry, High Back Entry)

Note in reference to Figure 10-22.

- 1. All conduits entering the section must be installed in a maximum of two rows.

10.1.1 Underground Cable-Terminating Facilities in Pull Boxes or Pull Sections

Figure 10-2 through Figure 10-26, all on Page 10- , provide diagrams and required dimensions for cable-terminating facilities in the pull boxes or pull sections. The following paragraphs describe the requirements for applicants who install these facilities. Applicants must:

- A. Ensure that one landing position per phase is available for each 100 amps of service capacity, as shown in Figure 10-2 , “ Landing Terminal Detail,” on Page 10- . Also, applicants must ensure that provisions have been made for stacking lugs.
- B. Ensure that bolts are provided with nuts, flat washers, and pressure-maintaining spring washers.
- C. Ensure that all parts are plated to prevent corrosion.
- D. Ensure that bolts are secured in place unless working access is provided on both sides of the mounting bus. If both sides of the bus are accessible, one set of bolts may be used to provide two terminal-mounting positions, one on either side of the bus.

NOTE: “Secured in place” means the stud will not turn, back out, or loosen in any manner when subjected to normal, -approved torques while tightening or loosening terminal nuts. This includes cross-threaded situations.

## 10. .1 . (continued)

- E. In the terminal-mounting area, ensure that a radial clearance of 1-1/2 inches is provided between any bus (including bolts) and any other bus (including horizontal cross-busing) or grounded surface, as shown in Figure 10-2 , “Spacing requirements,” on Page 10- .
- E CEPTIONS: The following are exceptions from these requirements.
1. The minimum clearance to the back of the pull section or to the front of the pull-section cover may be 1 inch.
  2. The neutral bus or termination may have a minimum clearance of 1 inch from any grounded surface.
- . Service cables passing over horizontal cross busing must have a minimum 2-1/2-inch radial clearance. This distance may be reduced to 1 inch if the horizontal bus is fully insulated.
- F. Ensure that each cable-mounting position has at least 8 inches of unobstructed space in front of the entire mounting surface when all of the conductors are in place. This space must be accessible from the front of the pull section.
- G. Ensure that the bus stubs are firmly secured to prevent bus misalignment and movement when the cables are installed. See Figure 10-2 , “Buses Accessible From Only One Side (Bolts Must Be Secured in Place),” and Figure 10-26, “Buses Accessible From Either Side (Mounting Surfaces on Both Sides of Bus),” both on Page 10- , for bus stub details through 2, 00 amps.
- . For nonresidential services, either single or three phase, 600 amps and above, PG&E requires applicants to install multiple sets of service conduit. Additionally, PG&E will require applicants to supply stacking lugs for terminating its cables in any installation that is rated nonresidential, three phase, 1,200 amps or greater.
- I. For nonresidential services, additional space (i.e., depth, width, and termination height) may be required in any section of switchboard, panelboard, or other enclosure used to terminate PG&E service cables. This additional space may be necessary to provide proper clearances between phases and grounded surfaces, as well as to accommodate the installation of service cable.
- . Applicants should review [umbered Document 06 928, “Methods and requirements for Installing on- esidential nderground Electric Services 0 600 olts to Customer-Owned Facilities.”](#) for the appropriate conduit and cable requirements for nonresidential service installations. Find this document in [Appendix C, “Electric and Gas Engineering Documents.”](#)

10. .1 . (continued)

- . PG&E does not allow applicants to install wall-mounted cable termination and pull enclosures for nonresidential, three-phase installations rated at 01 amps through 2, 00 amps. For those installations, PG&E requires a switchboard pull section or enclosure meeting the requirements shown in [Section 9, “Electric Metering: Components and Cable Terminating Facilities,”](#) Table 9- , “[Minimum Pad-Mounted \(Floor-Standing\) Switchboard Pull-Section Dimensions: Residential and Nonresidential, Single-Phase and Three-Phase.](#)” on Page 9-1 , and [Table 10-1, “Minimum Bottom-Fed Pull-Section Dimensions,”](#) on Page 10-2 , for bottom entry. Also, see [Table 10-2, “Pull Section Dimensions \(Minimums\) Below Ground Level,”](#) on Page 10- 1, for side or back entry.
- . See additional requirements in [Section 9, Subsection 9.10., “Underground Service Cable-Termination Section or Pull Box.”](#) on Page 9-10. The information, tables, and figures provide additional requirements for applicants who install wall-mounted and pad-mounted cable-termination and pull-section equipment.

NOTE: The utility point of service (i.e., service point) is defined as the approved enclosure and the terminated or spliced connections.

*cited in Cal. Rest. Ass'n v. City of Berkeley  
No. 21-16278am archived December 27, 2023*

10.1 (continued)

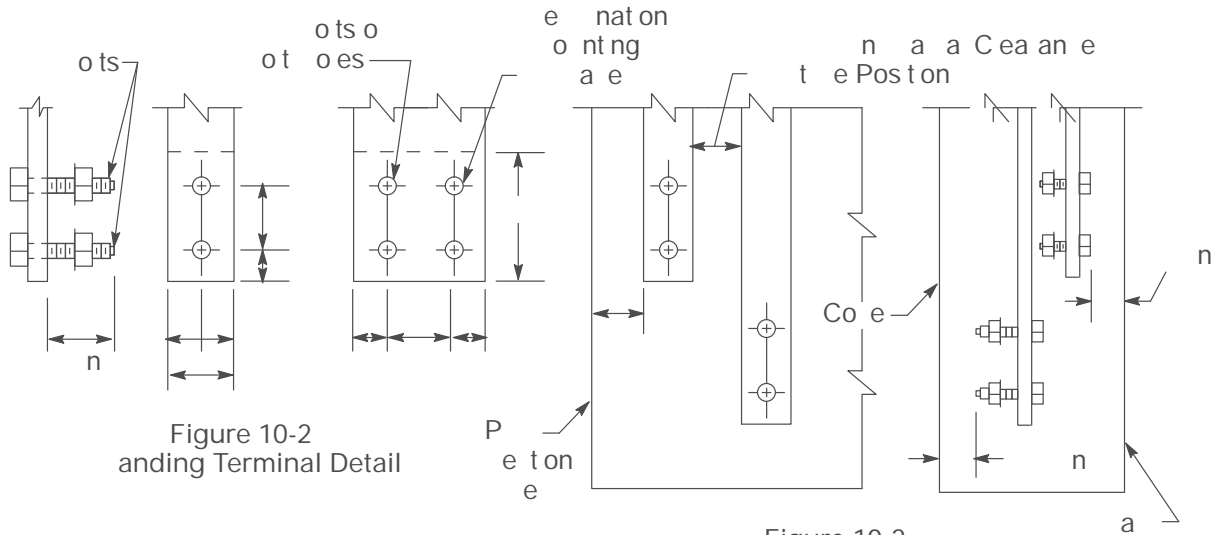


Figure 10-2  
Spacing Terminal Detail

Figure 10-2  
Spacing Requirements

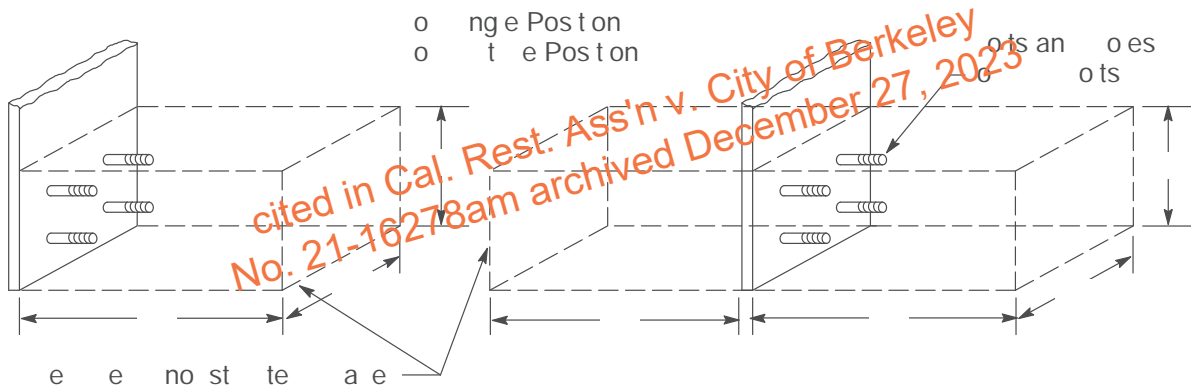


Figure 10-2  
Accessible From Only One Side  
(Volts Must Be Secured in Place)

Figure 10-2  
Accessible From Either Side  
(Mounting Surfaces on Both Sides of Bus)

10 Meter and Switch Sequence Requirements

PG&E will locate meters and metering equipment ahead of (i.e., on the supply side) the applicant's main switch and fuse or circuit breaker. Exceptions to this normal sequence are permitted only when required by electric codes and as allowed by PG&E.

## 10 Metering Transformer Compartments

The following requirements apply to applicants who are installing metering transformer compartments.

- A. Bus the CT compartments using a rectangular bus bar. See Figure 10-2 through Figure 10-8 on Pages 10-8 through 10-18 for more information.
- B. Ensure that the covers for metering transformer compartments are:
  - Constructed of 12-gauge steel (minimum).
  - Provided with lifting handles.
  - Attached with sealable studs and wing nuts or using other approved means.
- C. Use a copper or aluminum bus bar on both the line sides and load sides of all CTs. When links and supports are required for through-type CTs, ensure that the bus and removable links are constructed of a compatible material.
- D. Do not use PG&E's CTs for any purpose but metering.

Do not use the metering transformer compartment as a splicing or tap-making chamber. Ensure that load conductors do not re-enter or pass through a CT compartment even if the conductors are inside of a raceway.

- E. Do not use the bolts required for connecting a CT to attach other conductors.

## 10 Meter Panels

The following requirements apply to applicants who are installing meter panels.

- A. Except for remote metering enclosures, use only hinged meter panels in front of a metering transformer compartment. The meter panel must be hinged next to the test facilities.
- B. Ensure that a 30-inch tall dual-socket meter panel door is provided in pad-mounted switchboards supplying a demand load of 100 kilovolt amperes (kVA) or more. See Table 10- , "Dual-Socket Hinged-Meter Panel Requirement," below. See the 30-inch tall panel door, shown in Figure 10- on Page 10- .
- C. Two 15-inch tall meter panel doors are allowed for switchboards with voltages and ampacities not listed in Table 10- , "Dual-Socket, Hinged, Meter-Panel Requirement," on Page 10-39. Refer to Figure 10-29, "Standard Switchboard Service Section, 15-Inch Hinged Panel for Socket Meter and Test Switch," on Page 10- 2, for a 15-inch tall meter panel door. The two panel doors must come bolted together so they can swing open and close together. The bolts and nuts must be removable so the doors can also be opened or closed independently.
- D. Ensure that meter panels are constructed of 12-gauge steel (minimum) and are sealable, hinged, and reversible. Because the meter panels are reversible, the hinges can be used on either the right side or the left side of the panels.
- E. Note that the width of meter panels may sometimes require the service section to be wider than the minimum-allowable width of the transformer compartment.

## 10.6. (continued)

F. Mount self-contained meters on nonhinged panels, as shown in Figure 10-1 on Page 10-2 .

G. For switchboards that come with dual sockets, a test switch cover plate must be installed on the spare socket.

Table 10- Dual-Socket, Hinged, Meter-Panel Requirement

Service Voltage	Switchboard Supply Rating	10-Inch Tall Meter Panel Door Required <sup>1</sup>	Dual Meter Socket Required
0	5000	Yes	Yes
0	5000	Yes	Yes
0	5000	Yes	Yes

<sup>1</sup>Two 15-inch-tall doors are not allowed on these switchboards.

*cited in Cal. Rest. Ass'n v. City of Berkeley  
No. 21-16278am archived December 27, 2023*



10.6. (continued)

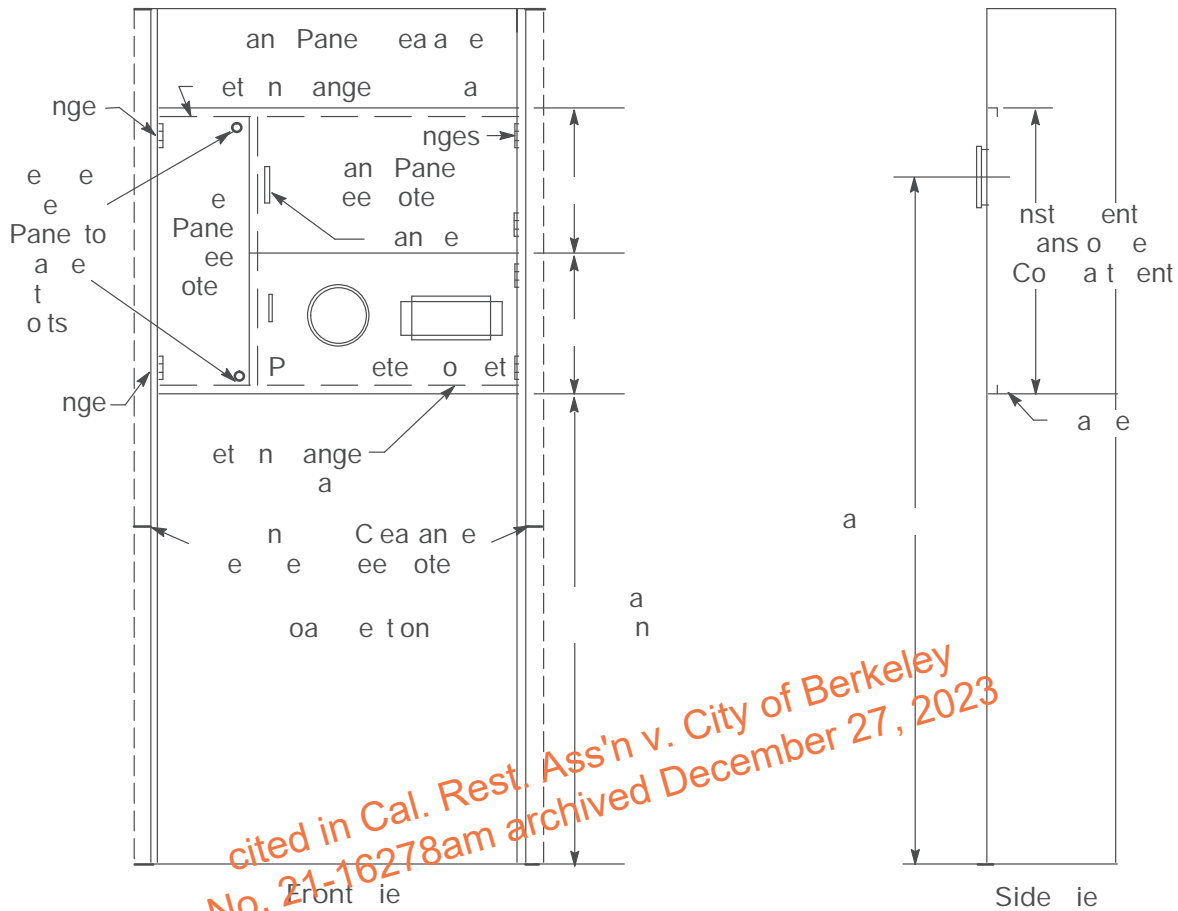


Figure 10-27  
Standard Switchboard Service Section with  
CT Compartment and Filler Panel, 0 volts- 600 volts

notes in reference to Figure 10-2 .

1. Use filler panels where the switchboard width exceeds the allowable meter panel width. It is allowed to hinge meter panels to hinged filler panels only if the filler panel is bolted to the switchboard in both corners of the filler panel opposite the hinges.
2. Make the grounding connection in the main switch or breaker compartment.
  - . In a split-panel arrangement, mount the kilowatt-hour (kWh) meter panel in the lower position.
  - . Equip meter panels and filler panels with stops to prevent the panels from swinging inward beyond the front surface of the switchboard.
  - . Ensure that all panels and covers are sealable.
6. Ensure that the meter panels can open 90° with the meter and test facilities in place. Ensure there is at least 12 inches of minimum clearance on the side where the meter panel door opens outward.

## 10.6. (continued)

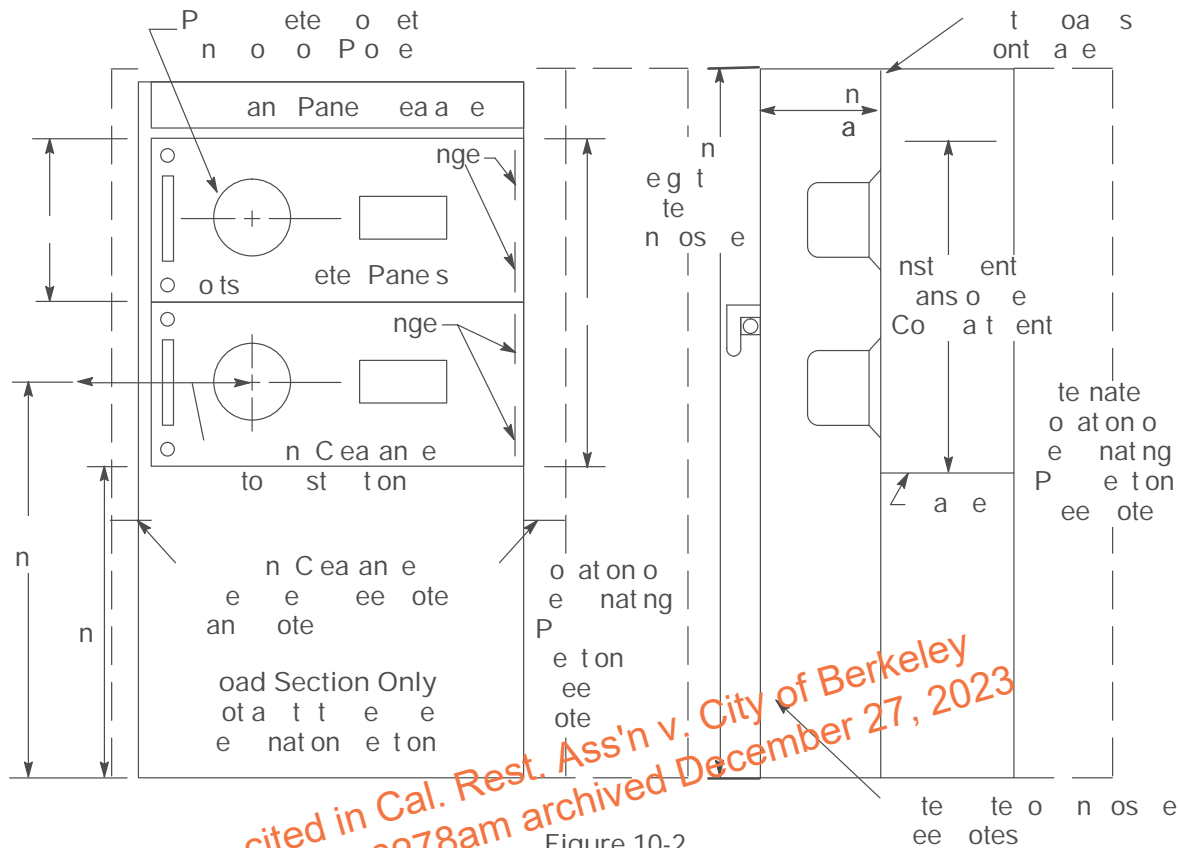


Figure 10-2

Low-Profile Switchboard Service Section,  
with CT Compartment, for Underground Service

Notes in reference to Figure 10-28.

1. Locate the terminating pull section beside or behind the metering and current transformer (CT) compartment. The metering and CT compartment must not be recessed back into the switchboard.
2. Use filler panels where the switchboard width exceeds the maximum-allowable meter panel width. It is allowed to hinge meter panels to hinged filler panels only if the filler panel is bolted to the switchboard in both corners of the filler panel opposite the hinges.
  - . Make the grounding connection in the main switch or breaker compartment.
  - . Equip meter panels and filler panels with stops to prevent the panels from swinging inward beyond the front surface of the switchboard.
  - . Ensure that all panels and covers are sealable.
6. Ensure that the meter panels can open 90° with the meter and test facilities in place. Ensure there is at least 12 inches of minimum clearance on the side where the meter panel door opens outward.
  - . Only for low-profile switchboards. Place the PG&E meter socket on the top panel.
8. Preferably low-profile switchboards should only be installed indoors.
9. Low-profile switchboards installed in outdoor applications require an outer enclosure that is a minimum of 68 inches tall. This is the required minimum working space height.

10.6. (continued)

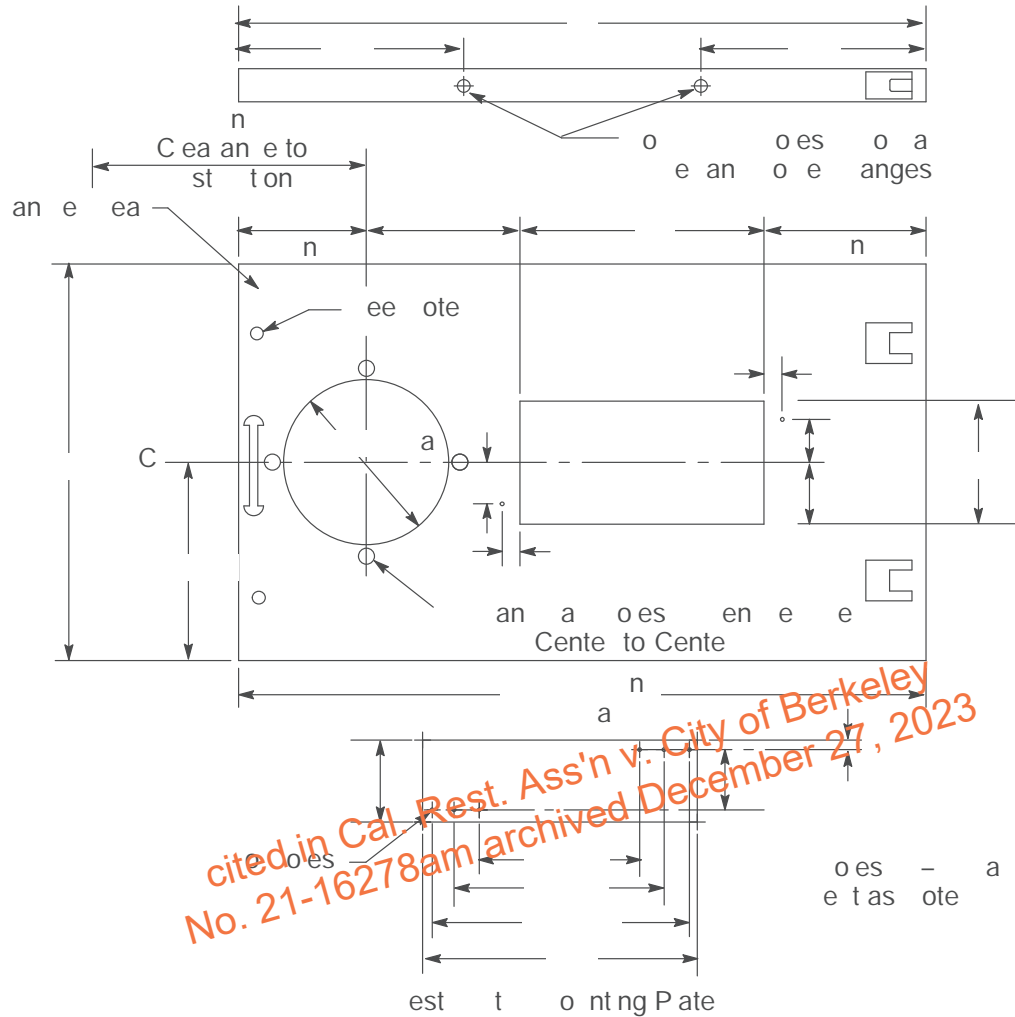


Figure 10-2

Standard Switchboard Service Section, 1 1/2-Inch Hinged Panel for Socket Meter and Test Switch

notes in reference to Figure 10-29.

1. Ensure that the switchboard manufacturer drills, taps, and slots the panel for the secondary test switch, as shown. Also, ensure that the switchboard manufacturer furnishes and installs the socket with a sealing ring.
2. Design the meter sockets to be installed on hinged panels for back (rear) connection.
  - . Use the outdoor or rain-tight enclosures shown in Figure 10- 1 through Figure 10- on Page 10- .
  - . Attach a handle at the unsupported end of the meter panel. Leave a minimum clearance of 1 inch from the handle to the meter socket.
  - . Ensure that hinges can support a 2 -pound load applied at the unsupported end with a maximum 1/8-inch sag when the panel is open.
6. Secure removable plates to the rear of the panel using screws that do not protrude through the face of panel.
  - . Ensure that the meter panels can open 90° with the meter and test facilities in place.
8. Ensure that all securing screws and sealing screws on the panels are captive. Studs and wing nuts must be sealable, when they are used.
9. Ensure that hinges are interchangeable and can be used on either the right side or the left side of the meter panels. When using clevis-type or removable pin-type hinges, ensure that the pin can be removed from the type of the meter panel.

10.6. (continued)

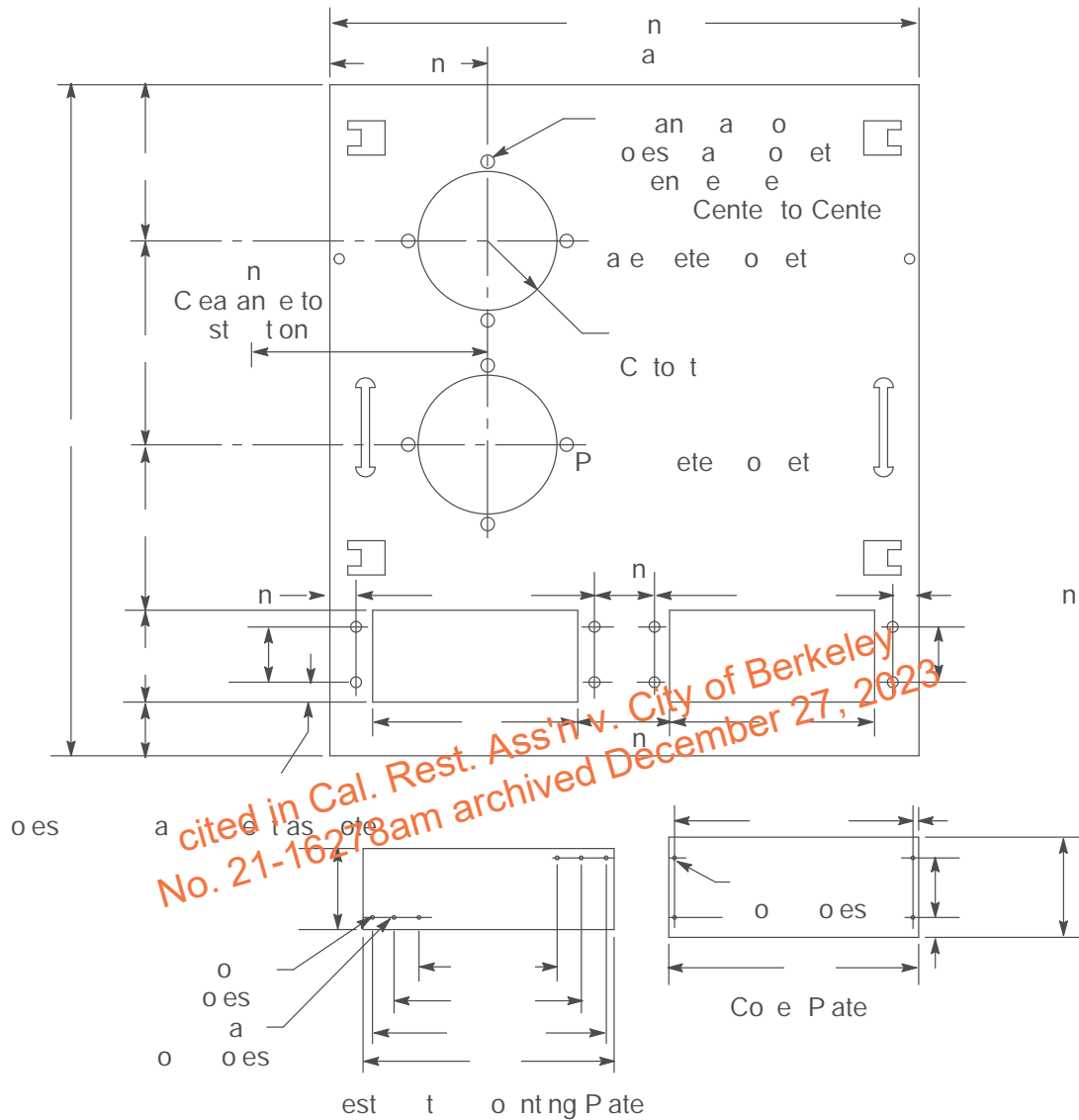


Figure 10- 0

Standard Switchboard Service Section, 0-Inch Panel for Socket Meters and Test Switches

Notes in reference to Figure 10- 0.

1. Meter socket openings may be on either the right or the left side of the panel.
2. Ensure that the switchboard manufacturer drills, taps, and slots the panel for the secondary test switch, as shown. Also, ensure that the switchboard manufacturer furnishes and installs the socket with a sealing ring.
- . Paint the removable plates and attached them to the panel.
- . Construct meter panels of 12-gauge steel (minimum). Ensure they are hinged and sealable.

Notes continued on the next page

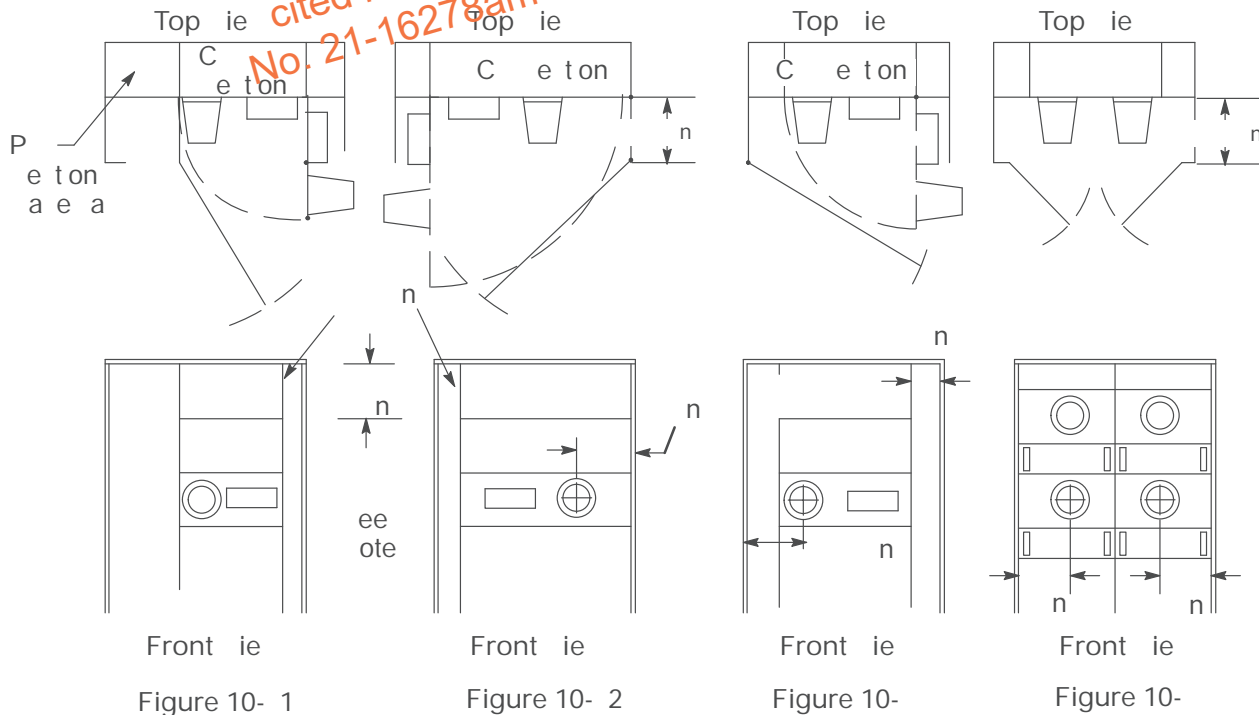
notes in reference to Figure 10- 0 (continued).

- . Ensure that hinges are interchangeable and can be used on either the right side or the left side of the meter panels. When using clevis-type or removable pin-type hinges, ensure that the pin can be removed from the top of the meter panel.
- 6. Ensure that hinges can support a 25-pound load applied at the unsupported end with a maximum 1/8-inch sag when the panel is open.
- . It is allowed to hinge meter panels to hinged filler panels only if the filler panel is bolted to the switchboard in both corners of the filler panel opposite the hinges.
- 8. Ensure that a hinged meter panel can be opened 90° with the meter and test facilities in place. When working with either recessed or enclosed meter panels, see Figure 10- 1 below.
- 9. Ensure that the panel has a handle attached on both sides.
- 10. All securing screws and sealing screws on the panel must be captive. Stud and wing nuts must be sealable, when they are used.
- 11. Design the meter sockets to be installed on hinged panels for back (i.e., rear) connection.
- 12. For panel widths of less than 26 inches, consult your local PG&E meter shop.

### 10.7 Transformer-Rated and Self-Contained Switchboards

Applicants may use switchboards consisting of a main disconnect (if required), individual meter sockets, and associated circuit breakers or switches for individually metered, multiple occupancies supplied from one service.

Figure 10- 1, Figure 10- 2, and Figure 10- 3, below, show standard switchboard service-section detail for transformer-rated meter sockets. Figure 10- 4, below, shows standard switchboard service-section detail for self-contained meter sockets rated from 0 amps through 225 amps.



### Outdoor or Rain-Tight Enclosures for Switchboards

Notes continued on the next page

notes in reference to Figure 10- 1, Figure 10- 2, Figure 10- , and Figure 10- on Page 10- .

1. Ensure that hinged meter panels and enclosure doors can be opened at least 90° with meter and test facilities in place.
2. For hinged meter panel designs, see Figure 10-2 on Page 10- 0 and Figure 10-28 on Page 10- 1.
  - . Ensure that enclosure doors can be secured in the 90° open position.
  - . For approved enclosure-locking provisions, see [Section , Subsection . . .](#), “[Electric Meter and Service Termination Equipment Rooms](#),” on Page -8.
  - . Ensure that outdoor or rain-tight enclosures are used.

## 10 Adding New Metering Equipment to Existing Switchboards

When applicants want to install a new meter panel or meter section and connect to the load side of an existing switchboard, the required method is to extend the bussing from the last meter or load section of the existing switchboard into a new meter section. See Figure 10- , “Existing Switchboard,” on Page 10- , as an example of how to extend the switchboard bussing.

Please contact the local project coordinator before interconnecting and adding load. Project coordinators must ensure that the existing PG&E facilities are upgraded, when necessary.

If the new meter panel or meter section cannot be connected to the end of the switchboard, the interconnection may be allowed, at PG&E’s discretion, in the utility termination section of the switchboard only if all of the following conditions below are met.

- A. The total aggregated ampacity of the new panel or new section plus the existing switchboard metering sections is not greater than the existing switchboard’s total (supply) ampacity rating. See Table 10- , “Adding New Meter Section Ampacities,” and Figure 10- , “Existing Switchboard,” both on Page 10- , to calculate the ampacities.
- B. PG&E calculates the new total demand load and, if needed, installs the additional service conductors required to meet that load. A larger transformer may also be required because of the new total demand load.
- C. PG&E identifies available spare landing positions on the terminating facilities. The spare landing positions are in addition to the number of landing positions required in Subsection 10. .1 ., “Underground, Cable-Terminating Facilities in Pull Boxes or Pull Sections,” on Page 10- , that must be reserved for existing and future installation of additional cables.
- D. The utility service termination section (typically 90 inches high) does not contain a main breaker compartment or a metering compartment. This termination section is dedicated only for terminating PG&E service cables. See Figure 10- , “Existing Switchboard,” on Page 10- .

If all of the conditions described above are met and PG&E approves the installation of the new meter panel or meter section, applicants must follow the applicable instructions provided in Item E. and Item F. on Page 10- 6.

10.8. (continued)

- E. Overhead Service: Applicants must locate the taps in a sealable compartment that is located above and separated from the CT and/or metering equipment compartment.
- F. Underground Service: Applicants must ensure that the taps are located in the underground service-termination pull section or pull box. In this instance, the applicant must ensure that the bus conductors terminate in a suitable, approved manner. Also, the applicant must ensure that the bus conductors are positioned so that the customer's incoming, service-entrance conductors and the tap connections do not encroach into PG&E's pulling area or interfere with PG&E's pull and termination facilities for service-lateral conductors.

NOTE: Due to various types of configurations and arrangements of switchboard compartments in some termination sections, the interconnection may not meet all of the requirements listed above and will be denied. One example is when the PG&E metering compartment or the customer's main breaker compartment is directly above the utility termination section. See Figure 10-2 on Page 10- 0.

Table 10- Adding Meter Section Capacities<sup>1</sup>

Example	Supply Section (oc 1) Capacity Rating	Meter Section, (oc 2) Capacity Rating	Meter Section, (oc 3) Capacity Rating	Aggregated Capacity of All Metering Selections, and Panels	Net Meter Equipment Tap Allowed
					do not exceed aggregate capacity of all metering selections and panels
					do not exceed aggregate capacity of all metering selections and panels

*cited in Cal. Rest. Ass'n v. City of Berkeley No. 21-16278am archived December 27, 2023*

<sup>1</sup> The total capacity of the metering section shall not exceed the capacity of the supply section.

10.8. (continued)

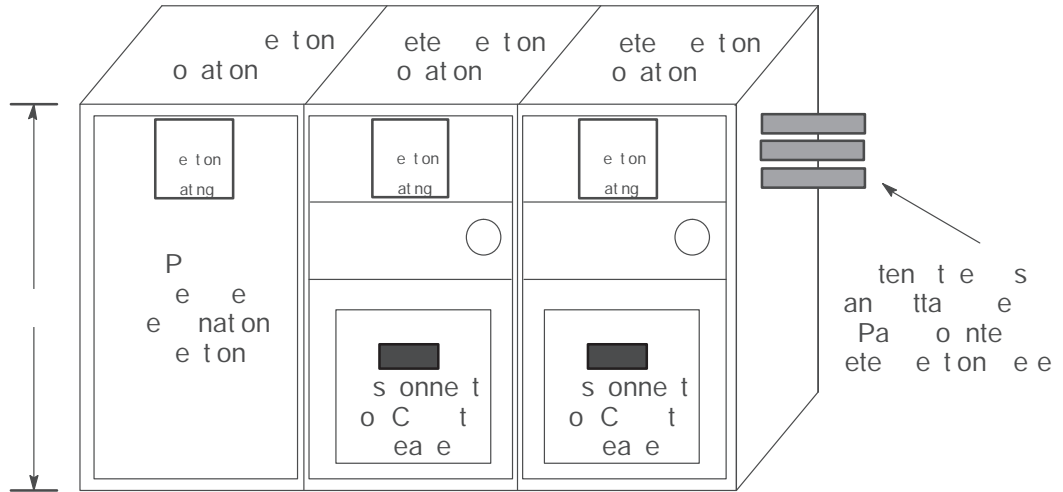


Figure 10-  
Existing Switchboard

*cited in Cal. Rest. Ass'n v. City of Berkeley  
No. 21-16278am archived December 27, 2023*



This Page Intentionally left Blank

*cited in Cal. Rest. Ass'n v. City of Berkeley  
No. 21-16278am archived December 27, 2023*

SECTION 11  
 ELECTRIC SERVICE ORDERS:  
 01 O T S T R O G  
 2 , 0 0 0 O T S N D  
 PRIM R S E R I C E S

*cited in Cal. Rest. Ass'n v. City of Berkeley  
 No. 21-16278am archived December 27, 2023*

SECTION 11 ELECTRIC SERVICE ORDERS:  
 T R O G 2 , 0 0 0 O T S N D PRIM R S E R I C E S  
 01 o t s

SECTION 11 ELECTRIC SERVICE TRIGGER  
T RO G 2 ,000 O TS ND PRIM R SER ICES

cited in Cal. Rest. Ass'n v. City of Berkeley  
No. 21-16278am archived December 27, 2023

## Section 11

### Electric Switchboards: 601 volts Through 24,000 volts, and Primary Services

---

#### 11.1 Scope

This section of the manual provides application and installation details for high-voltage switchboard metering equipment ranging from 601 volts through 24,000 volts.

#### 11.2 General Requirements

The following general requirements apply when installing high-voltage electric switchboards and primary services.

Find reference information for interconnections and primary services in Subsection 11.2, "Interconnection Requirements and Primary Services," on Page 11-1.

A. The specific switchboards voltages represented in this section are:

- 601
- 1,600
- 12,000
- 17,200
- 20,800

B. Applicants must ensure that manufacturers contact PG&E before fabricating the switchboards and request the specific information listed below.

- Service voltage, phase, and wiring.
- Meter panel requirements for the applicable rate schedule.
- Service-termination location.
- Switchboard and/or meter location.
- Size and number of service conductors.
- Other information and specifications necessary for fabricating switchboards (e.g., [Equipment Utility Service Requirements Committee EUSERC](#) manual, Section 100 requirements).

C. A manufacturer must submit three sets of drawings of the proposed equipment to PG&E for pre-approval before manufacturing the equipment. The drawings must include the contractor's name and address, the applicant's name, and the job location. The job location must be specific and can be the service address or Global Positioning System (GPS) coordinate's location. Field-design changes are not permitted without obtaining PG&E's approval before making the changes.

## 11.2. (continued)

D. Employees perform a field inspection of the switchboard at the jobsite. The switchboard is approved only when it meets all of the specified requirements.

NOTE: Potential transformers (PTs) are also called voltage transformers (VTs). The two terms are used interchangeably in Section 11.

E. PG&E must furnish and install fuses for PTs, as well as for the following equipment.

- Meters
  - Metering transformers
  - Test switches
  - All secondary wiring from the metering transformers to the meters
- When more than one switchboard is required, install a separate service section. Ensure that it is separated completely (i.e., barriered) from other service sections, pull sections, or service switches and disconnects.

## 11 Specific Requirements for High-Voltage Switchboards

The applicant must ensure that the equipment described below is provided and that the included construction requirements are followed precisely when installing high-voltage switchboards.

- cited in Cal. Inst. of Prof. Eng'rs v. City of Berkeley, No. 21-16278am, archived December 27, 2023*
- A. Provide and install the insulation barrier between the potential transformer (PT) disconnect switches and the PT section. The voltage disconnect switch handle must be visible when the outer door of the switchboard is opened.
  - B. Ensure that the insulated cables and conductors are made available to PG&E. PG&E personnel will make the connections between the PT fuse holders and metering PTs.
  - C. Provide an individual pulling eyebolt (shouldered type) above each of the current transformer (CT) positions to aid CT lifting. Shouldered eyebolts are required due to their rating for angular loading capacity.
  - D. Ensure that all ground buses are solid bus bars with dimensions of at least 1/2 inch x 2 inches. Ground buses must be constructed from either copper or aluminum.
  - E. Do not use flex braid on any section of ground buses.
  - F. Ensure that a ground bus bar is used for the PT disconnect.
  - G. Ensure that ground buses do not obstruct internal compartments, openings, conduits, or accesses to utility facilities, equipment, or extended work areas.
    1. Ensure that the rigid ground bus is located on the right or left side towards the front of the section to provide better accessibility for any work to be performed. This includes the PT, CT, and termination sections.

## 11. . (continued)

- I. PT Disconnect Switch: The following requirements apply to the PT disconnect switch.
1. Only use a gang-operated, “no-load” type, disconnect.
  2. The disconnect switch must have grounds in a blade-and-jaw configuration when it is opened.
    - . Do not use fused-drawer disconnect devices or fused, removable, section-type disconnect devices.
    - . Ensure that the maximum amount of operating force required to open and close a PT disconnect switch is no more than 0 foot-pounds.
    - . Ensure the PT disconnect-switch door has a viewing window, so the switch blades are visible.
  6. An interlocking system is required to ensure the PT disconnect is locked open fully before the PT compartment door can be opened and entered.
    - . Apply a label near the switch handle stating, “Meter & PT Disconnect Switch. Does not De-Energize Load.”
  - . Ensure that PG&E’s working space and clearance requirements are met. Confirm that there is an unobstructed, 8-foot area cleared in front of all access doors. These areas include the termination, CT, PT, and metering sections. This area is required for installing and removing PG&E’s safety grounds and other equipment. Maintain this clearance area at all times.
  - . Concrete floors or pads must extend out in front of the whole area a minimum of 96 inches, as measured from the outside of the equipment’s outer doors. See the requirements in [Section ., “Electric Metering: General,” Subsection . . . . “Working Space,”](#) on Page -1 .
  - . Mechanical Lug Connectors: Ensure that the requested size and number of lay-in lugs are provided on the rigid ground bus in each of the following sections. Each lug must be accessible and installed towards the front of the section.
    1. Three lugs in the PT section to terminate the neutral circuit connected to the ground bus in the CT compartment. The lugs should accept a wire range between 6 to 10 American Wire Gauge (AWG).
    2. Two lugs in the termination section to terminate CT and PT ground wires. The lugs should accept a wire range between 8 to 12 AWG.
      - . One lug in the termination section for the primary service concentric neutral ground wire. The lugs should accept a wire range between 2 AWG through 20 thousand circular mils (kcmil).
- M. Ensure the requirements in [Section ., Subsection .2., “Applicant Responsibilities,”](#) on Page - , are followed.
- . Ensure that permanent marking or labeling, indicating the service-voltage rating of the switchgear being supplied, is included on the exterior of all electric meter panels and all equipment doors or panels that provide access to the service terminations, PTs, and CTs.

## 11. . (continued)

- O. Provide a bare bus that is inches above and below the CTs. PG&E will use this bare bus as a safety ground.
- P. Ensure that the primary taps for the PTs are connected only to the line side of the metering CTs.

Another alternative allows applicants to mount the meter panel in front of the CT termination compartment if, when the meter panel is open, the compartment is isolated fully by a removable or hinged barrier. This barrier must be sealable using stud and wing assemblies.

- . To attach the safety grounds, install ball studs (1/2-inch through 1 -inch threads with insulating covers) on the line and load side of the CT bus units. Locate the studs less than inches from the end of the bus unit and orient them toward the compartment access opening. Also, install two ball studs on the ground bus inside the CT compartment.
- . Ensure that each section of the primary switchgear has been certified to all applicable standards by the Occupational Safety & Health Administration's (OSHA's) Nationally Recognized Testing Laboratory (NRTL) Program. The equipment also must meet the requirements of the Electric Utility Service Equipment Requirements Committee (EUSC) manual, as well as all applicable Greenbook requirements, and be approved by PG&E. Also, see Section , Subsection 2.1., "Approved Metering and Service-Termination Equipment," on Page -1. The following requirements also apply.
1. A certification label(s) must be affixed to the switchgear by its manufacturer (if qualified for self-certification) or by a qualified third-party agency (i.e., underwriters laboratories or other T), indicating that the switchboard meets all applicable standards.
  2. Due to the capacity of PG&E distribution circuits, primary switchgear must not have an ampacity rating greater than 600 amps. The maximum ampacity rating must be listed on the switchgear's nameplate label. Refer to Section 1, "General," Subsection 1.1 ., "Determining the Electric Service Rating," on Page 1-1 .
- S. Ground rods and wire: Install 2 ground rods, ground wire, and conduits for the primary service as shown in Figure 11-1, "Primary Switchgear Termination Section Pad Detail," on Page 11-6. These two ground rods are in addition to the grounding system already installed for the switchgear.

Connect a bare copper ground wire to both ground rods and to the switchgear rigid ground bus. Use 2 solid copper ground wire for 200 amp-rated services ( 2 and 1/0 primary cables) and 2 0 kcmil copper ground wire for services rated greater than 200 amps and up to 600 amps ( /0 and larger primary cables).

## 11. . (continued)

For switchgear installed indoors in an electrical room only, where there is a basement, garage, or other room in the building directly below the electrical room, applicants may use a concrete-encased grounding electrode from the building's grounding system (fer) instead of installing a ground rod inside the termination section. The concrete-encased grounding electrode typically may use electrically conductive steel reinforcing bars (rebar). The five following requirements also apply.

1. The rebar must be connected to the switchgear's grounding system.
  2. The rebar must be extended upward vertically out of the building's concrete floor or pad into the termination section a minimum of 6 inches to a maximum of 9 inches above the switchgear floor.
    - . The rebar must be placed and extended out of the switchgear floor the same as the ground rod shown in Figure 11-1, "Primary Switchboard Termination Section Pad Detail," on Page 11-6.
    - . A second grounding electrode (ground rod) must be installed outside below grade and away from the building or its foundation.
    - . Connect the two grounding electrodes (rebar and ground rod) together with a ground wire as described above and in Figure 11-1.
- T. Submit a termination section drawing detail on all of the switchboard drawings submitted to PG&E. The drawing detail must show the position and details such as size, wire gauge and measurements (separations where applicable) of the conduit(s), conduit window, ground rods, ground wire, rigid ground bus, lugs, and additional internal components.
- . Install a transparent, insulated, inner door as a safety barrier in front of the termination section, and CT section (if separate) for all switchboards 601 volts through 2,000 volts.
    1. Construct the safety door from a solid piece of clear acrylic that is a minimum 6 millimeters (or 1/4-inch) thick and resistant to damage by impact or puncture.
    2. Ensure the acrylic is rated for the voltage served.
      - . The safety door must extend from the top to the bottom and side-to-side to cover the entire open area of the section, including all energized parts.
      - . A metallic frame or parts may be used to support the door, but metallic parts should be limited to maximize the amount of visibility through the door.
      - . Maintain all clearances.
  - 6. The acrylic door must be operable with hinges on one side, and a handle and provisions to secure the door in the open and closed positions on the opposite side.
    - . Identify the door on all switchboard drawings submitted to PG&E.



11. . (continued)

- **Meter Panel Door:** The primary switchgear meter panel door is required to have a minimum of two sockets and a maximum of three sockets, excluding the California Independent System Operator (ISO) socket, as shown in Figure 11-2, “ inged Meter Panel with Multiple Sockets for 2, 00- to 2 ,000- Service,” on Page 11-8., and Figure 11- , “ inged Meter Panel with Dual Socket for 2, 00- Through 2 ,000- Service,” on Page 11-9. Consult PG&E for meter–socket questions. If requested, PG&E will furnish and install test switches and wiring for the additional, manufacturer installed meter sockets.

The PG&E metering circuit must not be extended into other sections of the switchboard.

- **Heating Equipment:** Manufacturer-installed heaters or heating equipment that prevent moisture buildup inside the switchgear are allowed if they are placed in the back of the section(s) and do not interfere with PG&E equipment or obstruct the working area around the equipment.

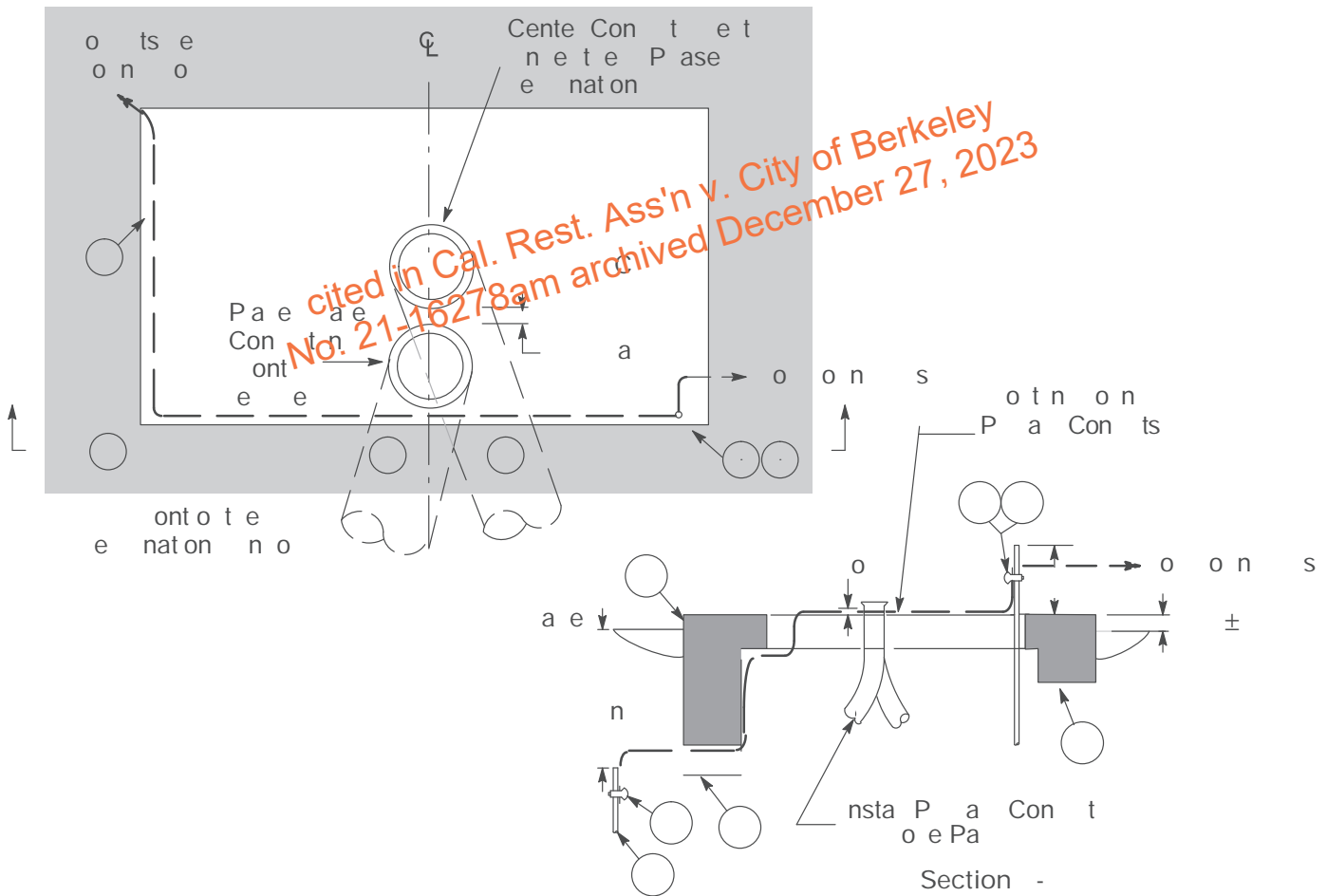


Figure 11-1  
Primary Switchgear Termination Section Pad Detail

11. . (continued)

Notes in reference to Figure 11-1 on Page 11-6.

1. Primary conduits must be centered in the window, as shown.
2. Maintain a 6-foot minimum separation between ground rods.
  - . The ground wire must be a continuous wire that connects to, and runs from, the outside ground rod, buried in the ground or in the pad, to the inside of the termination section. The wire continues on the inside running above the pad, through the primary window, and attaches to the inside ground rod. Finally, the continuous wire must run from the inside ground rod to a mechanical lug on the switchboard ground bus inside the termination section. The mechanical lug must accept wire between 2 AWG through 2/0 kcmil.
  - . On switchgear termination sections that have a raised floor above the concrete pad, ensure the ground rod installed inside the termination section extends 6 to 9 inches above the switchgear section floor.
  - . Install a spare conduit only when required by PG&E.

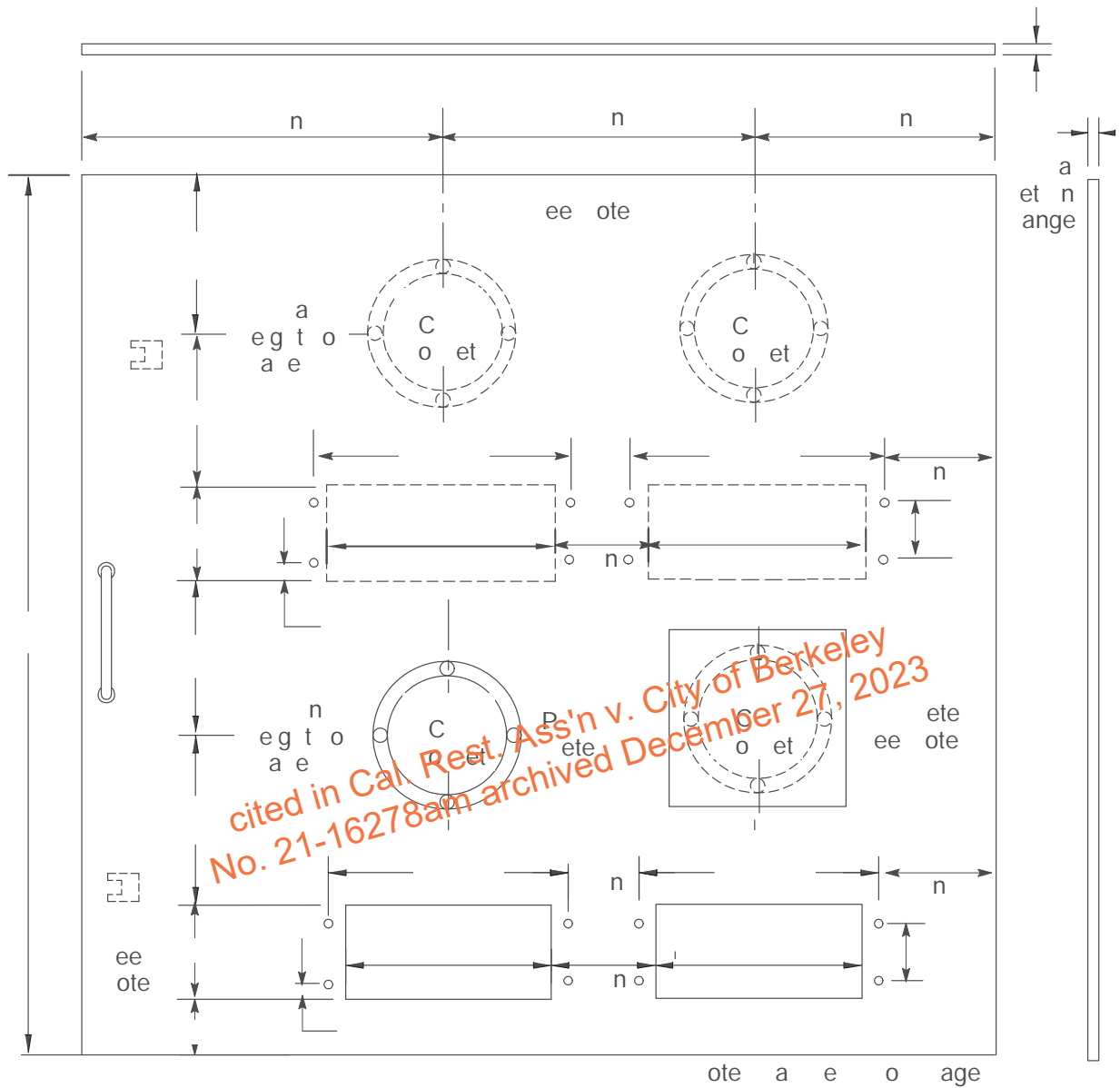
Table 11-1 Bill of Materials for Concrete Pad

Item	Quantity	Description	Code	Unit
		Pad Concrete	-	-
Steel		Reinforcing Steel	-	-
		Anchor Bolts	-	-
		Concrete	-	-
Cable		Conduit	-	-
		Ground Rod	-	-
Steel		Anchor Bolt	-	-
Steel		Conduit	-	-

*cited in Cal. Rest. Ass'n v. City of Berkeley No. 21-16278am archived December 27, 2023*

See table on Page 11-6 for details on quantities and descriptions. The table lists materials for the concrete pad, including concrete, reinforcing steel, anchor bolts, conduit, and ground rods. The quantities and codes are as shown in the table above.

11. . (continued)



o es a e t as ote

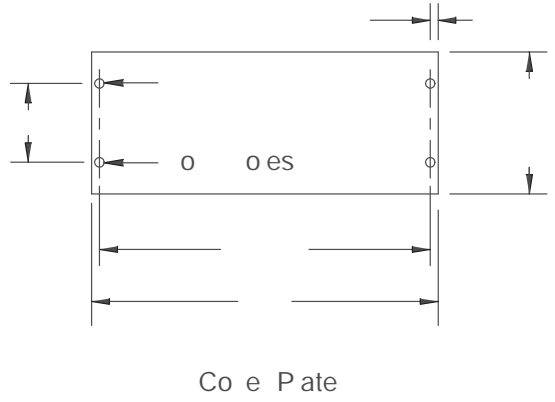
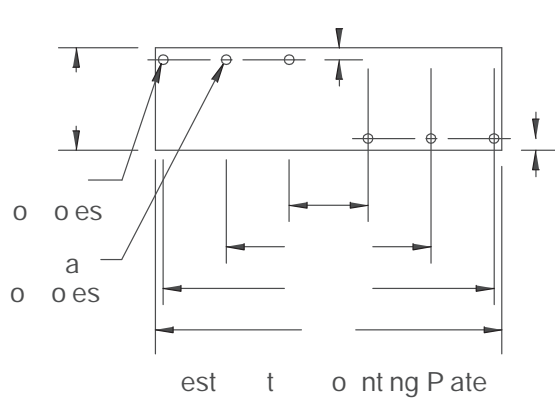


Figure 11-2  
inged Meter Panel ith Multiple Sockets for 2, 00- Through 27,000- Service

Section 11, Electric Switchboards: 601 volts Through 27,000 volts and Primary Services

11. . (continued)

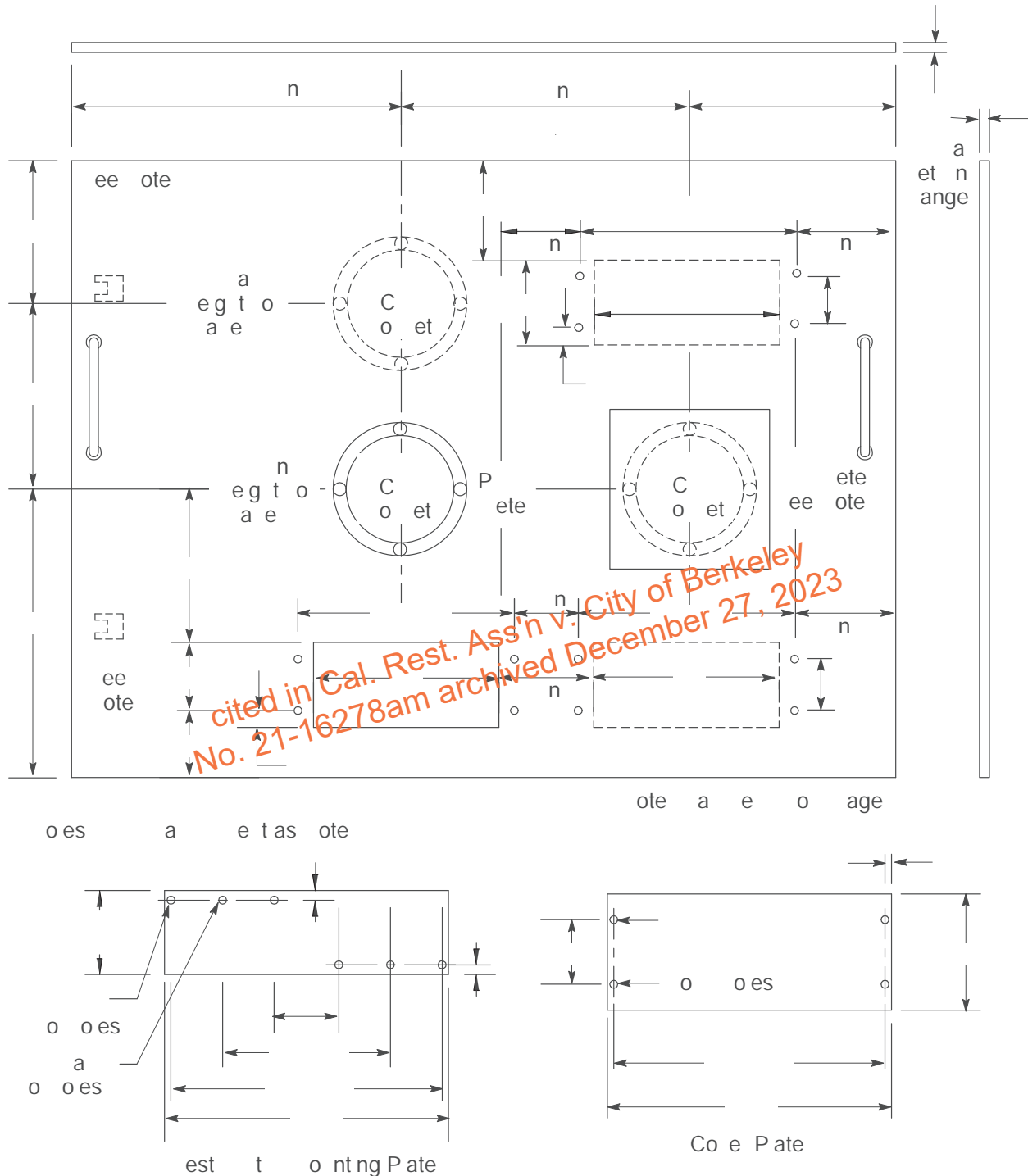


Figure 11-  
 inged Meter Panel ith Dual Socket for 2, 00- Through 27,000- Service  
 otes in reference to Figure 11-2 and Figure 11- .

1. The panel must be constructed using 12 gauge (minimum) steel and furnished with meter sockets, sealing rings, slotted openings, and a removable plate for installing a secondary test switch. The slotted opening and removable plate edges must be smooth to prevent damaging the meter wiring.

Notes continued on the ne t page

**11. . (continued)**

otes in reference to Figure 11-2 and Figure 11- , continued.

2. Provide an ISO Meter Cast ing Mounting Blank Cover. hen a cast meter-mounting ring is provided, the screws used to attach to the meter panel must provide a minimum 1/8-inch clearance between the screw heads and the back of the ring.
  - . Auxiliary power connections are not allowed.
  - . The removable plates must be attached to the rear of the panel with screws that do not protrude through the face of the pane.
  - . Meter sockets must be designed to connect from the back. A maximum of meter sockets are allowed.
6. The panel must be equipped with hinges. The hinges must permit the panel to open to 90 degrees. hinges must be located on the same side as the PG&E meter socket. usually, the meter socket panel does not need to be interchangeable, right or left, unless it causes an unsafe egress or other safety-related issue.
  - . hen fully opened, the panel must support a 2 -pound load applied at the unsupported end, with a maximum sag of 1/8 inch.
8. The panel must have a handle attached to both sides.
9. Stud and wing nuts must be sealable when used.
10. Consult PG&E before using a panel with a width of more than 8 inches.
11. The meter panel is required to have a minimum of two sockets and a maximum of four sockets including the ISO socket. Consult PG&E for meter-socket requirements.

*cited in Cal. Rest. Ass'n v. City of Berkeley  
No. 21-16278am archived December 27, 2023*

Section 11, Electric Switchboards: 601 volts Through 2,000 volts and Primary Services

11. . (continued)

Table 11-2 Dimensions for High-voltage Meter Enclosures

Specifications	Switchboard Voltage Rating			
	2,000	10,000/17,000	7,200/17,000	20,000/20,000
	(In Inches)			
Minimum clearance				See to the enclosure page page
Minimum clearance				
Dimensions	Minimum	Minimum	Minimum	
Dimensions	Minimum	Minimum	Minimum	
Dimensions C	Minimum	Minimum	Minimum	
Dimensions (Do not install neutral insulator)	-	-	-	
Dimensions	Minimum	Minimum	Minimum	
Dimensions	Minimum	Minimum	Minimum	
Dimensions	Minimum	Minimum	Minimum	
Dimensions separation C Center				
Dimensions separation				
Dimensions separation separation				
Dimensions separation separation				

cited in Cal. Rest. Ass'n v. City of Berkeley  
 No. 21-16278am archived December 27, 2023

Clearance to the top of the enclosure when the enclosure is open  
 Clearance to the top of the enclosure when the enclosure is closed

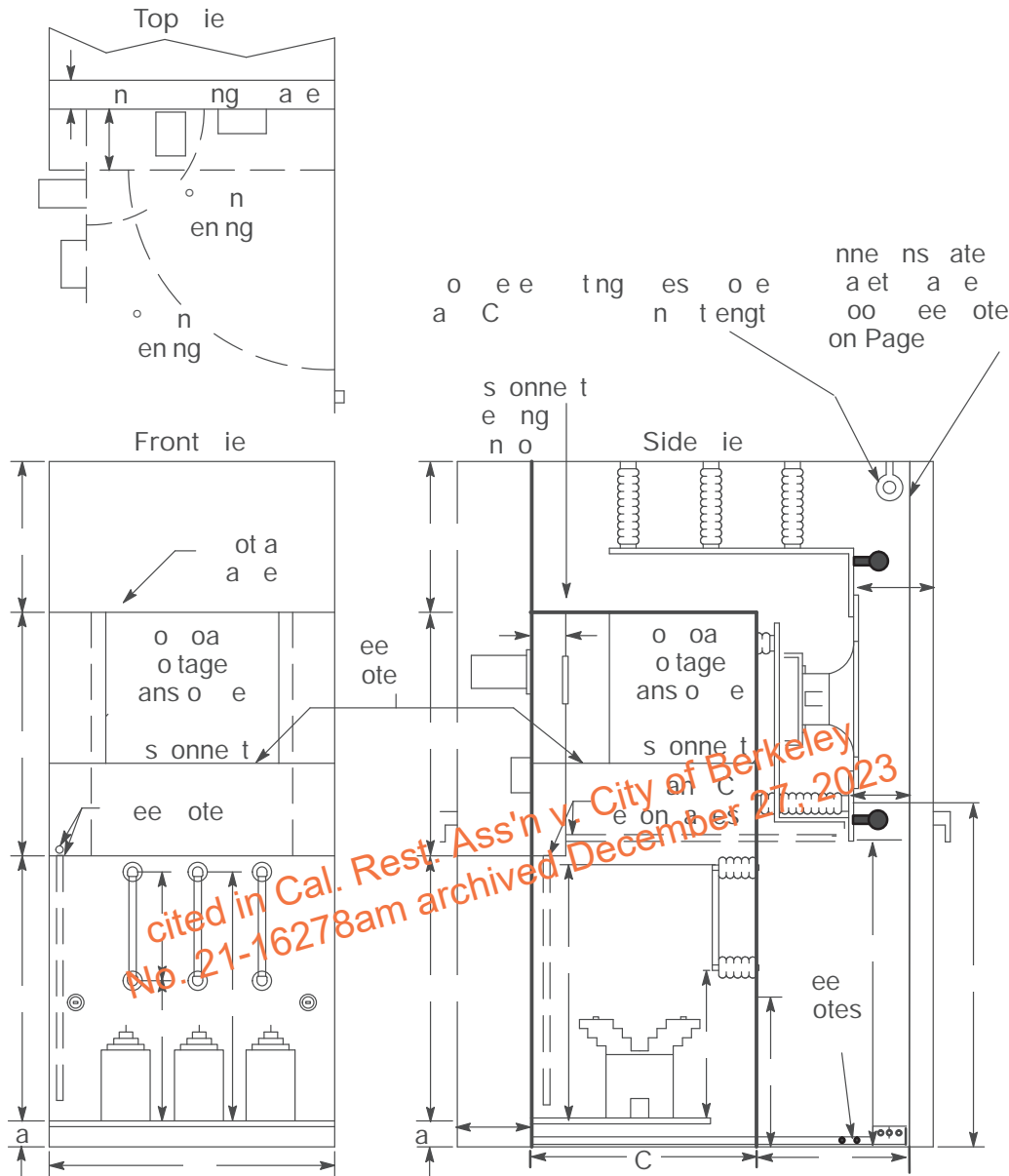


Figure 11- Typical, high-voltage Metering Enclosure: 2,000- Through 17,000- Service

Notes in reference to Figure 11 - .

1. Install the meter's panel hinge on the opposite side from the enclosing door hinge on a weatherproof unit. This allows the meter panel to be opened a full 90°.
2. Locate the 1-inch, non-metallic T and CT secondary conduits on the same side as the meter's panel hinges.
  - . Electrically insulated barrier.
  - . Applicants must ask the local project coordinator to contact the PG&E electric meter department to ensure that the types and models of instrument transformers they intend to install (i.e., Ts and CTs) are approved for use in high-voltage switchgear.
  - . For T Mounting rail materials and installation details, refer to the [EUSERC](#) manual, Drawing 0 .
6. Ensure that the grounding bus extends on either the left or right sides of the CT compartment's access area. Also, ensure that the ground terminals are two aluminum-bodied mechanical lugs accepting a range of 6 AWG through 20 kcmil conductors. Finally, ensure that they are identified with a label reading, "Safety Grounding Point For Utility Use Only."
- . Do not install the neutral insulator bushing in the PT compartment.

11. . (continued)

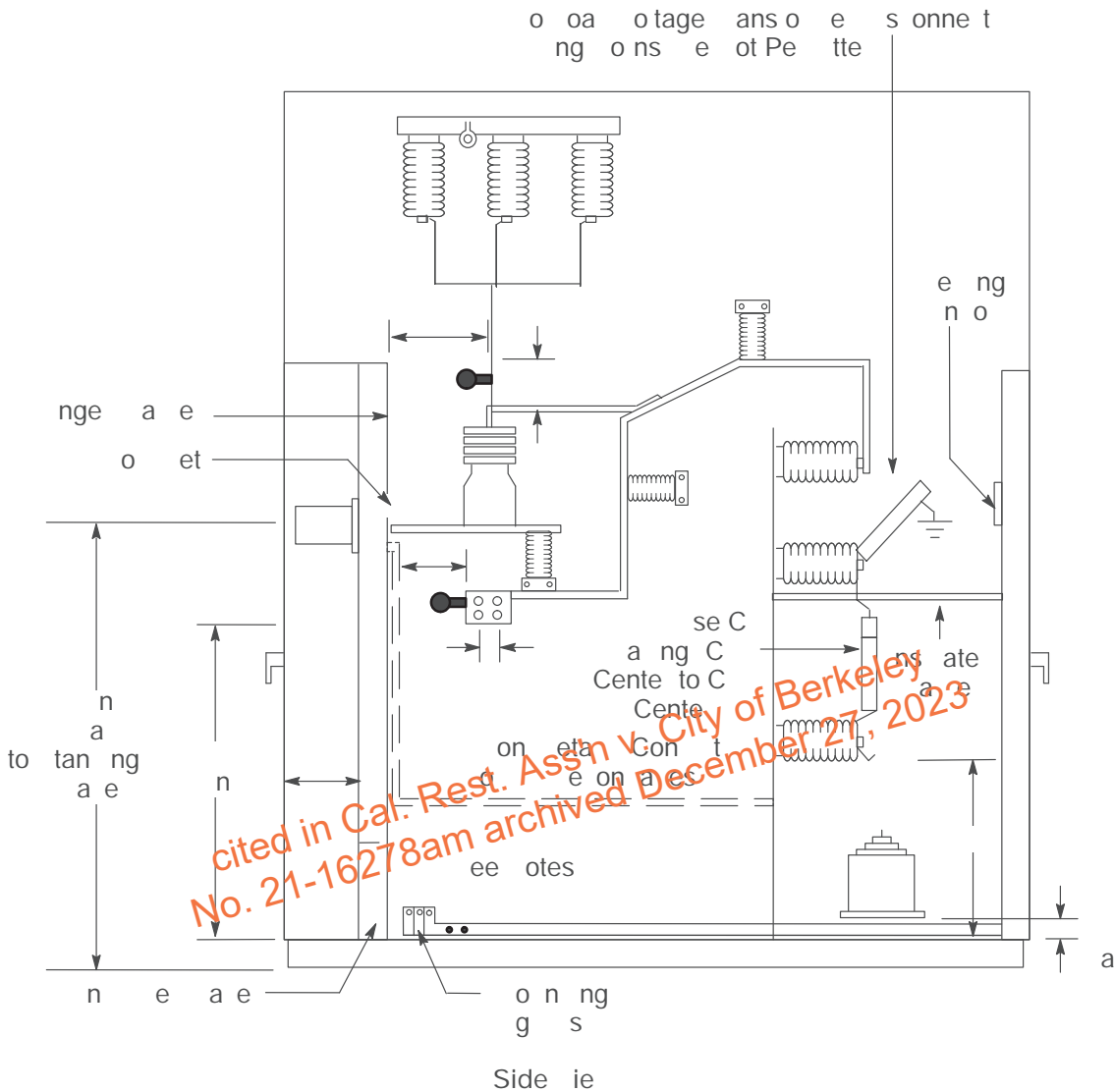


Figure 11- Typical, High-voltage Metering Enclosure: 17,001- Through 2,000- Service

Notes in reference to Figure 11- above and Figure 11-6 on Page 11-1 .

1. For rear access to the door, refer to the [EUSERC](#) manual, Drawing 00, Sheet 2, Note .
2. Connect the primary taps for CTs to the line-side of metering CTs.
  - . When switchgear is mounted on rails, include a permanent platform, level with the bottom of the enclosure, in the switchgear installation to provide a clear and level working space in front of the metering compartment.
  - . Ensure that the ground bus extends on either the left or right side of the CT compartment's access area. Also, ensure that the grounding terminals are 2 aluminum-bodied mechanical lugs accepting a range of 6 American Wire Gauge (AWG) through 20 thousand circular mils (kcmil) conductors. Finally, ensure that they are identified with a label reading "SAFETY GROUNDING POINT FOR TERMINATION."
  - . Clearance to any part of the enclosure, including flanges and inner walls.
6. For CT Mounting rail materials and installation details refer to the [EUSERC](#) manual, Drawing 0 .
  - . Do not install the neutral insulator bushing in the PT compartment.



11. . (continued)

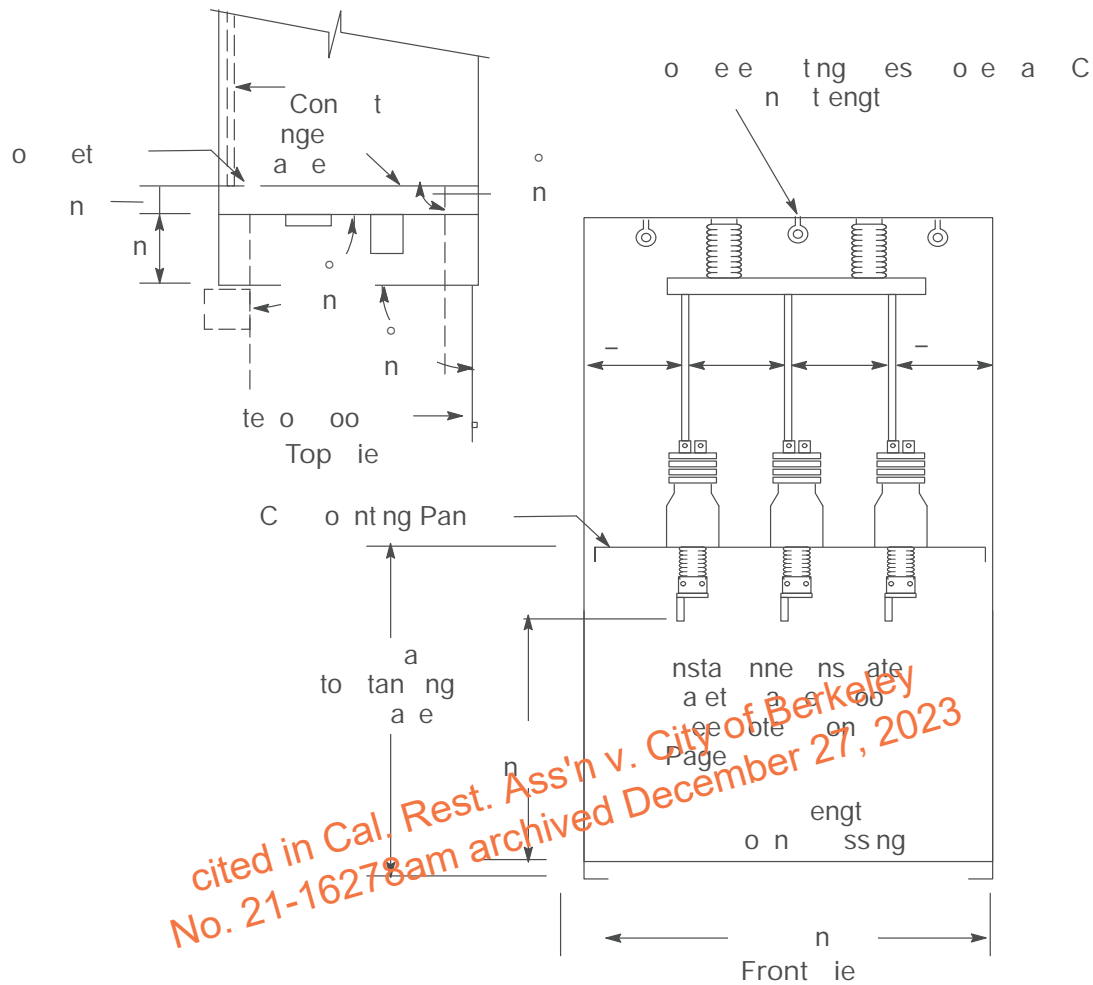


Figure 11- Typical, igh- oltage Metering Enclosure, 17,001- Through 2 ,000- Service

11 Interconnection Re uirements and Primary Services

hen new or existing applicants request services above 600 volts, refer to PG&E [umbered Document 09 6 6, "Primary Electric Service Equipment."](#) for technical information about primary services. This document is located in [Appendix C, "Electric and Gas Engineering Documents."](#)

If applicants intend to interconnect their generation facilities to PG&E's power system, they must refer to the [PG E Distribution nterconnection andbook](https://www.pge.com/en_US/large-business/services/alternatives-to-pge/distribution-handbook.page). ([https://www.pge.com/en\\_US/large-business/services/alternatives-to-pge/distribution-handbook.page](https://www.pge.com/en_US/large-business/services/alternatives-to-pge/distribution-handbook.page)).

## 11 Primary Switchgear Located Below Ground Level

When applicants want to install primary switchgear in an electrical meter room below the ground level, applicants must follow all of the requirements in this subsection. Switchgear must not be installed more than one level below grade. If the following requirements in this section cannot be met, then the switchgear must be installed at ground level.

PG&E requires a nonstandard design for switchgear, at all primary voltage levels, when installed below grade. This nonstandard design incorporates an additional pull section for the cable to ensure there is adequate separation between the cable terminations and the service entrance point into the switchgear to reduce the potential of water intrusion into the switchgear's termination section.

PG&E requires that applicants submit drawings for review during the initial design stage of their project and before procuring a primary switchgear.

The following additional requirements apply.

- A. **Additional Pull Section:** Below-grade primary switchgear must have a separate independent pull section that is next to and connected with the termination section. The primary conduits stop at this pull section and the cables run through the pull section and then into the termination section. The pull section must be the same height and depth as the termination section. The wall separating the two sections must have a window for the cables to run through from the pull section to the cable termination bus stubs inside the termination section. The following items are required in the pull section.
  - Cable hanger provisions at the top of the pull section
  - Moisture barrier to contain possible water intrusion
  - Cable blocks or support system on the bottom of the switchgear floor to ensure cables stay off of the floor or pad
- B. **Back or Side Entry:** The conduit and service entering the switchgear must enter the upper back or upper side of the additional pull section no lower than 18 inches from the top of the section.
- C. **Conduit:** The primary service conduit installed in the public property (franchise) area must not be at a depth below grade greater than 60 inches. Conduit may not extend more than 20 feet past the building foundation and into the electric meter room. The conduit must be continuous without breaks or junction boxes in between. Conduit entering the switchgear must enter the upper side or back of the additional pull section.
- D. **Water Drainage System:** To prevent water from accumulating in meter rooms, applicants must ensure they design and construct the electrical meter room to quickly discharge any water that may enter the switchgear and the below-grade electrical meter room.
- E. **Cable Termination Height:** PG&E requires a nonstandard design with higher cable terminations for switchgear installed below grade. The elevated terminations allow for the cables to be bent, installed, and attached correctly. The cable terminations must be between 60 inches to 72 inches. This is measured from the first bolt on the termination bus to the bottom of the cable entrance window.

11. . (continued)

F. Reference figures: The following figures show the design of the additional pull section and illustrates how the pull section adjoins the termination section. Also, a detail is provided for the window in the wall between the two sections. The minimum cable termination heights, as well as section widths, are shown in these illustrations.

- Figure 11- , “Additional Side or Back Switchgear Pull Section High Entry,” below
- Detail A, “Cable Entrance Window,” on Page 11-1 .

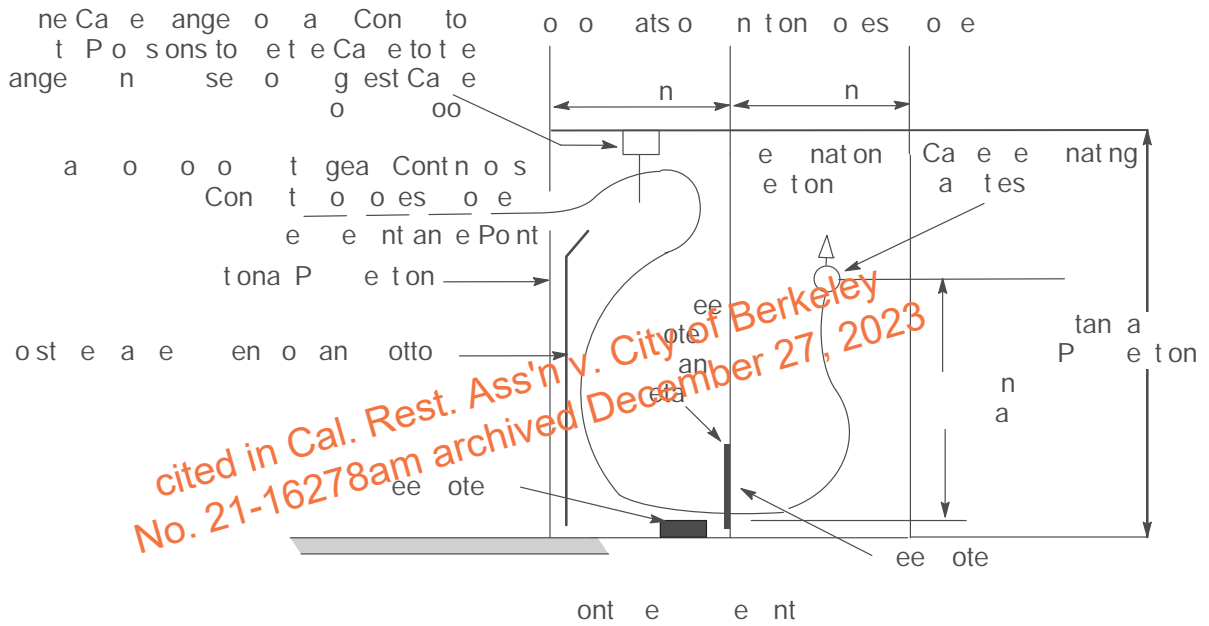
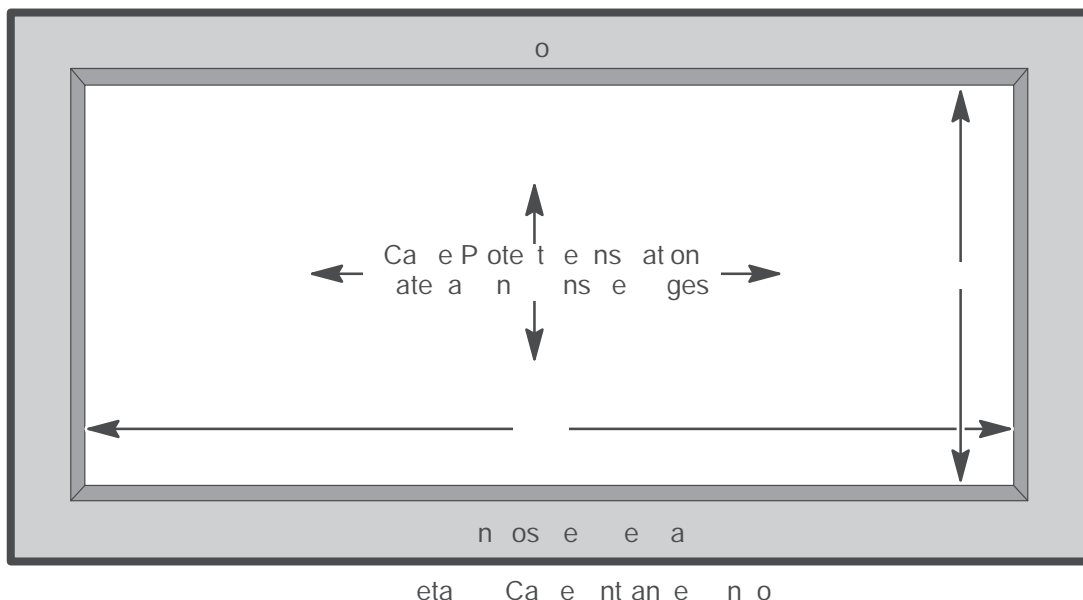


Figure 11-7  
Additional Side or Back Switchgear Pull Section High Entry

11. . (continued)



Notes in reference to Figure 11- .

1. Ensure that the height and depth of the additional pull section are exactly the same as the terminating section. The width must be a minimum of 2 inches.
2. The height of the cable entrance window above the top of the pad is 4 inches maximum. Ensure that the window size is a 2 inches wide by 2 inches tall. Insulate all inside edges of the window opening to prevent damage to the cables. See Detail A above..
- . Cables must not lie on the concrete pad or ground. The applicant must provide a cable support system to keep the cables off the ground. Otherwise, the applicant must supply cable blocks using PG&E Material Code 62118.

This Page Intentionally left Blank

*cited in Cal. Rest. Ass'n v. City of Berkeley  
No. 21-16278am archived December 27, 2023*

PPENDI

CRON MS & G OSS R

PPENDI  
CRON MS & G OSS R  
cited in Cal. Rest. Ass'n v. City of Berkeley  
No. 21-16278am archived December 27, 2023

CRON MS & G OSS R

PPENDI

cited in Cal. Rest. Ass'n v. City of Berkeley  
No. 21-16278am archived December 27, 2023

## Appendix Cronyms and Glossary

---

### Cronyms

A	ampere, amps
ac	alternating current
A	authority having jurisdiction
AIC	amperes interrupting capacity
A SI	American National Standards Institute
A G	American wire gauge
Btu	British thermal unit
CC	Code of California Regulations
CDF	California Department of Forestry and Fire Protection
CGT	California Gas Transmission
C	centerline
CP C	California Public Utilities Commission
CT	current transformer
DA	direct access
DASMMD	Direct Access Standards for Metering and Meter Data
DAS	direct access service request
dc	direct current
DG	distributed generation
DOT	U.S. Department of Transportation
EF	excess flow valve
ESP	energy service provider
E SE C	Electric Utilities Service Equipment Requirements Committee
G.O.	General Order
G S	galvanized rigid steel
GT&D	Gas Transmission and Distribution
DD	Horizontal Directional Drilling
DPE	high-density polyethylene

cited in Cal. Rest. Ass'n v. City of Berkeley  
 No. 21-16278am argued December 27, 2023



## Appendix A: Acronyms and Glossary

---

 cronyms (continued)

z	hertz
ID	inside diameter
IMC	intermediate metal conduit
IPS	iron pipe size
k	kilo (1,000)
kcmil	thousand circular mils
.O.	knock out
k A	kilovolt ampere
MDMA	meter data management agent
MSP	meter service provider
EC	ational Electric Code
EM	net energy metering
O	overhead
OS A	Occupational Safety and ealth Administration
PCC	point of common coupling
psig	pounds per square inch gauge
P C	California Public esource Code
PT	potential transformer
P E	public utility easement
P C	polyvinyl chloride
scfh	standard cubic feet per hour
S A	state responsibility areas
SS	soft start
TBF	test-bypass facility
T SS	transient voltage surge suppressor
G	underground
	nderwriters aboratories
.S.	nited States
SA	nderground Service Alert
	ultraviolet

---

cronyms (continued)

volts

FD      variable Frequency Drive

T        voltage transformer

watt

C        water column

*cited in Cal. Rest. Ass'n v. City of Berkeley  
No. 21-16278am archived December 27, 2023*

This Page Intentionally Left Blank

*cited in Cal. Rest. Ass'n v. City of Berkeley  
No. 21-16278am archived December 27, 2023*

---

## Glossary

**Applicant:** This word is used generically throughout the manual to refer to the Pacific Gas and Electric Company (PG&E) customer, or to the person or persons representing the PG&E customer in the application/construction process, including a contractor, design consultant, or installer. The word “customer” will be used only when the word “applicant” is not appropriate. Also, PG&E will sometimes be referred to as the “Company” throughout this manual.

**Attachment Structure:** A support that connects the service drop to the structure while maintaining the clearances required for the service drop.

**Bac -Pressure Protection:** A check valve between the downstream (i.e., after) section of the meter and the upstream section of the applicant’s piping. This check valve prevents back-flow.

**Barricade (Pedestrian Traffic):** A suitable barricade to help ensure the safety of pedestrians is a heavy, wire-mesh fencing that is securely supported and is capable of protecting people from the hazards created by the moving parts of stationary machinery.

**Barricade (Vehicular Traffic):** A suitable barricade for vehicular traffic is concrete-filled steel pipes, 12 inches or greater in diameter, securely set in an adequate concrete pour for support. Also allowed only for some job types is a sleeve-mounted vehicle barricade where the sleeves are set in concrete.

**Branch Service Pipe:** A pipe that branches off from a gas service pipe to serve two or more applicants.

**Conduit System:** A system that includes conduits, conduit bends, conduit fittings, and all related components (e.g., bell ends and cable protectors) that are needed to install PG&E cables and conductors.

**Cover:** The standard distance between the outer surface of an underground facility and the final grade level.

**Double Throw Switch:** A switch that isolates the applicant’s electrical system from that of the electrical corporation or state or local agency.

**Drip Loop:** A minimum 18 inches of service-entrance wiring that extends out from the service weatherhead.

**Excess Flow Valve (EFV):** A device installed in a gas service line at or near the main. An EFV is used to stop the flow of gas if the velocity of the gas passing through the valve creates a pressure difference across the valve that is greater than a specified design limit.

**High-Voltage Power Lines:** Generally, high-voltage power lines are any overhead lines that connect from pole to pole. These lines typically are 600 volts and greater.

**B:** Short-radius conduit fitting. Also known as a service elbow.

## Glossary (continued)

**Low-Growth Zone:** Applicants must establish a 1-foot low-growth zone on both sides of all new, electric, high-voltage lines. The zone under the electric power lines should be a low-growth, tree-planting zone and/or a shrub- and flower-planting zone.

**Main Service Disconnect:** A fusible switch, circuit breaker, or other approved disconnect means for controlling all of (and only) the energy registered by that meter. When the governing code or ordinance permits, the disconnect means may consist of a group of fusible or circuit-breaker disconnects.

**Mixed-Use Projects:** Construction projects that include both commercial and residential loads.

**Non-Utility Facilities:** Subsurface facilities not owned by any person, corporation, partnership, business, trust, or public agency belonging to a regional, one-call notification system.

**Pad-Mounted (Floor Standing) Equipment:** Service termination and metering equipment that are manufactured to be installed and attached to permanently installed, ground-mounted concrete pads or floors.

**Point of Attachment:** In areas served from overhead lines, PG&E will install an overhead service drop from the Company's distribution line to a point of attachment on the applicant's residence, building, or structure. The point of attachment may be either on the building wall near the PG&E line or on a periscope fixed to the building's roof, usually not more than 18 inches in back of that wall.

**Positive Means:** A device that, when used or operated, interrupts or prevents the flow of current to or from the electrical system. Also, a positive means provides the device operator or user with a visual or definite indication of the existing condition or state of the electrical system.

**Residential:** Class of customers commonly served at either 120/200 volts or 120/208 (network) with amperage ranging from 100 amperes to 200 amperes. Mobile homes installed on foundations also are classified as residential customers.

**Secured In Place:** The stud will not turn, back out, or loosen in any manner when subjected to normal, code-approved torques while tightening or loosening terminal nuts. This includes cross-threaded situations.

**Service Delivery Point (Electric Supply):** The point where PG&E's service drop wires/conductors connect to the applicant's service-entrance conductors for an overhead service. For an underground service, either the point where PG&E's service cables/conductors connect to the applicant's electric meter panel, switchboard, or service termination equipment or the point where PG&E's service cables/conductors connect directly to applicant's service-entrance conductors.

## Glossary (continued)

**Service Delivery Point (Gas Supply):** The point where PG&E's facilities connect to the applicant's house pipe (i.e., houseline). For residential and small commercial meter sets, the service delivery point is the point where the male threads of the applicant's houseline connect to the female threads of PG&E's gas service tee fitting. Some commercial and industrial installations do not have service tees installed therefore, the gas supply service delivery point is the first weld or fitting after the PG&E-installed bypass valve downstream of (i.e., after) the meter.

**Service Elbow:** Short-radius conduit fitting. Also known as an "B".

**SmartMeter™ Advanced Meter Reading System:** A meter using the latest radio frequency technology to transmit meter reads automatically from the gas and electric meters. This allows PG&E's applicants to monitor their daily usage information.

**Standard Delivery Pressure:** The gas service pressure provided to the service delivery point at 2 inches of water column (WC). This is approximately 1/2 pounds per square inch gauge (psig), as measured at the gas meter outlet.

**Switchboard Service Section:** The section of an applicant's switchboard provided specifically for terminating the service conductors and for housing the metering transformers (if required), revenue meters, test facilities, and service switch or breaker.

**Tariff:** A schedule of rates or charges of a business or a public utility.

**Test Block:** A test block is a specific type of test-bypass device. A test block is used for self-contained metering exclusively.

**Test-Bypass Facility:** Any mechanism used to bypass meter sockets. A test-bypass facility is used for self-contained metering exclusively.

**Utility Point of Service (i.e., Service Point):** The approved enclosure and the terminated or spliced connections.

**Wall-Mounted Equipment:** Service termination and metering equipment that are manufactured to be installed and attached to the sides of permanent structures.

Wall-mounted equipment include building walls, panelboard structures, poles, posts, and communication pedestals.

**Multi-Utility Piping or Facilities:** Includes, but is not limited to, water, bioswales, storm sewer, sanitary sewer, steam, liquid fuels, oil, diesel, sprinkler, irrigation, spigots, downspouts, drain or leach lines, propane, or lines for other liquids or volatile, heavier-than-air gases.

**Working Space:** An area in front of the meter, the meter enclosure, and the service-conductor termination and pulling facilities. A working space permits access to the equipment and provides a safe working environment for personnel.

This Page Intentionally Left Blank

*cited in Cal. Rest. Ass'n v. City of Berkeley  
No. 21-16278am archived December 27, 2023*

PPENDI  
ELECTRIC AND GAS SERVICE DOCUMENTS

PPENDI  
ELECTRIC AND GAS  
SERVICE DOCUMENTS

*cited in Cal. Rest. Ass'n v. City of Berkeley  
No. 21-16278am archived December 27, 2023*



PPENDI  
E  
E  
C  
T  
R  
I  
C  
N  
D  
G  
S  
S  
E  
R  
I  
C  
E  
D  
O  
C  
M  
E  
N  
T  
S

*cited in Cal. Rest. Ass'n v. City of Berkeley  
No. 21-16278am archived December 27, 2023*

## Appendix B Electric and Gas Service Documents

---

Appendix B contains the following PG&E utility documents:

### Landscaping Guides

- [Community Wildfire Safety Program Guide to Landscaping in High Fire-Threat Areas](#)
- [Guide to Safe Landscaping Near Gas Pipelines](#)
- [Guide to Safe Landscaping Near Underground Electric Lines](#)
- [Tree Planting Matrix Tables](#)

### Miscellaneous Utility Documents

- [Engineering Material Specification EMS- 12 , “Backfill Sand”](#)
- [Street Light Conduit Detail](#)
- [Utility Standard TD-S , “Joint Trench,” Appendix B, “Joint Trench Configurations and Occupancy Guide”](#)

### Utility Bulletin

- [TD-0 819 -B00 “Joint Trench, Backfill, and Warning Tape Requirements for Electric Distribution-Only Trenches”](#)
- [TD- B-001, “Updated Separation Requirements For Conduit in Joint Trench”](#)

### Utility Procedure

- [TD- 106P-01, “Enhanced Vegetation Management Pre-Inspection Procedure”](#)

This document is not in the printed manual and is available only in the online version of the [Greenbook](#) on [www.pge.com/greenbook](http://www.pge.com/greenbook).

Applicants should access PG&E’s Internet website at [www.pge.com/greenbook](http://www.pge.com/greenbook) to find the latest versions of, and updates to, these documents. Also, applicants may contact their local PG&E service planning offices to ensure their documents are current.

NOTE: See [Table FM-1, “Service Planning Office and Inspection Desk Contact Information,”](#) at the front of this manual starting on Page iv, for specific contact numbers listed by area.

Applicants should refer to PG&E’s Community Wildfire Safety Program Guide to Landscaping in High Fire-Threat Areas (included on the following two pages) for updated guidance on extending the defensible space around your property, specifically around power lines. Following this guidance could help save both real estate and lives.

cited in Cal. Rest. Ass'n v. City of Berkeley  
No. 21-16278am archived December 27, 2023



# Community Wildfire Safety Program Guide to Landscaping in High Fire-Threat Areas

Following California's recent wildfires, we are working together with customers in high fire-threat areas to create safe space between trees, limbs and power lines. This work is an additional precautionary measure intended to help reduce the risk of wildfire and keep you, your neighbors and your community safe.



Similar to landscaping within the defensible space around your home, the right plant in the right place around power lines can extend the defensible space around your property. When planting near power lines, follow these guidelines:

### DO:

- ✓ Use fire-resistant ground covers and shrubs that may resist ignition (please note that fire-resistant does not mean the plant is fire proof)
- ✓ Use high-moisture plants that have low sap or resin content
- ✓ Use plants that tend to not accumulate dry, dead material
- ✓ Use plants that grow low and close to the ground
- ✓ Use native species to your area
- ✓ Follow the proper spacing distances, as outlined in this guide
- ✓ Check with your local nursery for fire-resistant plants that are adaptable to your area and ensure plants are properly maintained and spaced for growth
- ✓ Remember to always properly maintain the health of your landscaping, ensuring proper watering and pruning when necessary

### DO NOT:

- ✗ Plant trees near homes, sheds, electric poles or other infrastructure
- ✗ Use plants that contain fine or dry material such as twigs and needles (e.g. Junipers and Cypresses)
- ✗ Use plants that contain flammable substances such as oils, resins, wax, or pitch; these plants may have aromatic leaves or have a strong odor when crushed
- ✗ Use plants that produce a large volume of litter
- ✗ Introduce invasive plant species to your specific area

Spacing between vegetation can help reduce the potential for fire to spread. Depending on the slope of your property, the table below outlines the horizontal distance recommended between trees and shrubs, and the vertical distance needed between the lowest tree branch and the ground or vegetation underneath the tree.

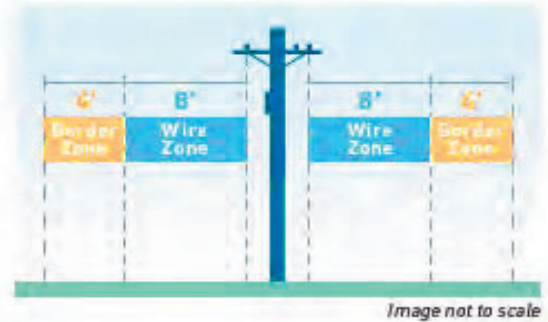
### HORIZONTAL SPACING:

Slope	Distance between tree canopies	Distance between shrubs
Flat to mild slope (less than 20%)	10 feet	2 times the height of the shrub (i.e. a 2 foot tall shrub must be 4 feet away from all other vegetation)
Mild to moderate slope (20%-40%)	20 feet	4 times the height of the shrub
Moderate to steep slope (greater than 40%)	30 feet	6 times the height of the shrub

### VERTICAL SPACING:

Slope	Distance from lowest tree branch to the ground or vegetation
Flat to mild slope (less than 20%)	6 feet
Mild to moderate slope (20%-40%)	10 feet
Moderate to steep slope (greater than 40%)	15 feet

The right plant in the right location can enhance the defensible space around your home. Below is a list of groundcovers, perennials and shrubs that are compatible in certain areas around power lines. Please note that the suggested list is not all-inclusive.



**Wire Zone** — 8 feet from either side of the conductor, plants should not exceed 12" in height at maturity.

**GROUNDCOVERS:**

<b>Bellflower</b> <i>(Campanula portenschlagiana)</i>	<b>Creeping Phlox</b> <i>(Phlox subulata)</i>	<b>Hens and Chicks</b> <i>(Sempervivum species)</i>	<b>Speedwell</b> <i>(Veronica species)</i>	<b>Purple Iceplant</b> <i>(Delosperma cooperi)</i>
<b>Carpet Bugleweed</b> <i>(Ajuga reptans)</i>	<b>Creeping Thyme</b> <i>(Thymus praecox)</i>	<b>Japanese Pachysandra</b> <i>(Pachysandra terminalis)</i>	<b>Star Jasmine</b> <i>(Trachelospermum jasminoides)</i>	<b>Rock Cress</b> <i>(Aubrieta deltoidea)</i>
<b>Crane's Bill</b> <i>(Geranium incanum)</i>	<b>Dead Nettle</b> <i>(Lamium species)</i>	<b>Mahala Mat</b> <i>(Ceanothus prostratus)</i>	<b>Orange Gazania, Treasure Flores</b> <i>(Gazania Mitswa Orange)</i>	<b>Western Sword Fern</b> <i>(Polystichum munitum)</i>
<b>Creeping Mahonia</b> <i>(Mahonia repens)</i>	<b>Dianthus, Garden Carnation or Pinks</b> <i>(Dianthus species)</i>	<b>Sedum or Stonecrops</b> <i>(Sedum species)</i>	<b>Pink Pussytoes</b> <i>(Antennaria rosea)</i>	<b>Wild Strawberry</b> <i>(Fragaria species)</i>
				<b>Yellow Iceplant</b> <i>(Delosperma nubigenum)</i>

**PERENNIALS:**

<b>Basket-of-Gold</b> <i>(Aurinia saxatilis)</i>	<b>Columbine</b> <i>(Aquilegia species)</i>	<b>Evening Primrose</b> <i>(Oenothera species)</i>	<b>Sea Thrift</b> <i>(Armeria maritima)</i>	<b>Western Columbine</b> <i>(Aquilegia formosa)</i>
<b>Blanket Flower</b> <i>(Gaillardia varieties)</i>	<b>Coneflower</b> <i>(Echinacea purpurea)</i>	<b>Heartleaf Bergenia</b> <i>(Bergenia cordifolia)</i>	<b>Sun Rose</b> <i>(Helianthemum nummularium)</i>	<b>Yarrow</b> <i>(Achillea species)</i>
<b>Chives</b> <i>(Allium schoenoprasum)</i>	<b>Coreopsis or Tickseed</b> <i>(Coreopsis species)</i>	<b>Lamb's Ear</b> <i>(Stachys byzantina)</i>		

**Border Zone** — 4 feet from Wire Zone, shrubs should not exceed 48" in height at maturity.

**SHRUBS:**

<b>Beach or Sandhill Sage, Coastal Sagewort</b> <i>(Artemisia pycnocephala)</i>	<b>Creeping Boobiala</b> <i>(Myoporum parvifolium)</i>	<b>Creeping Holly</b> <i>(Mahonia repens)</i>	<b>Dwarf Mock Orange</b> <i>(Fittosporum Wheeler's Dwarf)</i>	<b>Point Reyes Ceanothus</b> <i>(Ceanothus gloriosus)</i>
--	---	--	--	--

The above list includes plants suited for most California climate zones, however each location is different. PG&E makes no representation or guarantee that these plants are suitable for every location. Please consult your local nursery for more information.

Visit us at [pge.com/wildfiresafety](http://pge.com/wildfiresafety) to learn more about PG&E's Community Wildfire Safety Program. For more information and additional lists of potentially suitable, fire-resistant plants, visit [readyforwildfire.org/Fire-Safe-Landscaping](http://readyforwildfire.org/Fire-Safe-Landscaping) or [firesafecouncil.org](http://firesafecouncil.org).

\*PG&E refers to Pacific Gas and Electric Company, a subsidiary of PG&E Corporation. ©2018 Pacific Gas and Electric Company. All rights reserved. CYM-0718-0193

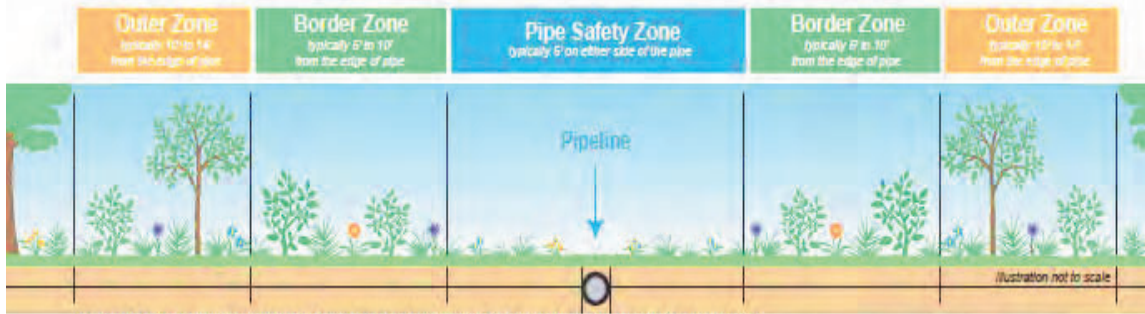
Appendix B: Electric and Gas Service Documents



## Community Pipeline Safety Initiative

### Guide to Safe Landscaping Near Gas Pipelines

When planning new landscaping near underground utilities, it's important to remember that the right plant in the right location can both enhance the natural beauty of your home and help protect the safety of your community. Trees and plants located too close to gas transmission pipelines can delay emergency access for safety crews and damage pipes. Below is a list of ultra-drought tolerant plant types that are safe in certain locations around the pipeline. Please note the suggested list is not all-inclusive.



Please note easement widths can vary and the above represents best practices and guidance for safe landscaping near gas pipelines.

**Pipe Safety Zone** Lawns, flowers, low-profile grasses and low-growing herbaceous plants are permitted within the Pipe Safety Zone. See the list below for plant suggestions.

- |  |   |  |  |   |
|--|---|--|--|---|
| azure penstemon*<br>( <i>Penstemon azureus</i> )   | California poppy*<br>( <i>Esochscholzia californica</i> ) | grama grass*<br>( <i>Bouteloua</i> spp.)     | purple needle grass*<br>( <i>Stipa pulchra</i> ) | stonecrop* (Sedum spp.)   |
| belladonna lily<br>( <i>Amaryllis belladonna</i> ) | chalk lettuce<br>( <i>Dudleya</i> spp.)                   | June grass*<br>( <i>Koeleria macrantha</i> ) | sea lavender*<br>( <i>Limonium</i> spp.)         | Hyacinth* (Hyacinthus spp.)                                     |
| blue eyed grass*<br>( <i>Sisyrinchium bellum</i> ) | daffodil<br>( <i>Narcissus</i> spp.)                      | kangaroo paw<br>( <i>Angozanthos</i> spp.)   | slimy milkweed*<br>( <i>Asclepias speciosa</i> ) | UC Verde buffalograss<br>( <i>Buchloe dactyloides</i> UC Verde) |
| Bulbine<br>( <i>Calyphus</i> spp.)                 | dymondia<br>( <i>Dyandia margaretae</i> )                 | Monardella<br>( <i>Monardella</i> spp.)      | silverbush<br>( <i>Convolvulus oneorum</i> )     | yarrow* ( <i>Achillea</i> spp.)                                 |
|  |   |  |  | yellow sundrops<br>( <i>Calyphus</i> spp.)                      |

**Border Zone** Small to medium shrubs with a trunk or main branch less than 8" in diameter at full maturity are permitted within the Border Zone. Diameter is measured at chest height. See the list below for plant suggestions.

- |   |   |  |  |   |
|---|---|--|--|---|
| Adam's needle<br>( <i>Yucca filamentosa</i> )       | California fuchsia*<br>( <i>Epilobium canum</i> ) | coyote brush*<br>( <i>Baccharis pilularis</i> )        | pipstem clematis*<br>( <i>Clematis lasiantha</i> ) | silver bush lupine*<br>( <i>Lupinus albus</i> )         |
| agave*<br>( <i>Agave</i> spp.)                      | California lilac*<br>( <i>Ceanothus</i> spp.)     | island tree poppy*<br>( <i>Dendromecon</i> spp.)       | rockrose*<br>( <i>Cistus</i> spp.)                 | sticky monkey flower*<br>( <i>Mimulus aurantiacus</i> ) |
| bear grass<br>( <i>Nolina microcarpa</i> )          | California native sage*<br>( <i>Salvia</i> spp.)  | manzanita*<br>( <i>Arostaphylos</i> spp.)              | sacaton*<br>( <i>Sporobolus</i> spp.)              | westringia<br>( <i>Westringia</i> spp.)                 |
| buckwheat*<br>( <i>Eriogonum</i> spp.)              | California sagebrush*<br>( <i>Artemisia</i> spp.) | matilija poppy*<br>( <i>Romneya coulteri</i> )         | smoke tree<br>( <i>Cotinus coggygria</i> )         | wild rye grass*<br>( <i>Leymus</i> spp.)                |
| bush anemone*<br>( <i>Carpenteria californica</i> ) | coffeeberry*<br>( <i>Rhamnus californica</i> )    | mountain mahogany<br>( <i>Cercocarpus betuloides</i> ) | snowberry*<br>( <i>Symphoricarpos</i> spp.)        | wooly blue curls*<br>( <i>Trichostema lanatum</i> )     |

**Outer Zone** Large shrubs and small trees with a trunk less than 36" in diameter at full maturity are permitted within the Outer Zone; however, if space allows, we recommend planting trees at an even greater distance from the pipeline. Diameter is measured at chest height. See the list below for small tree suggestions.

- |   |   |   |  |   |
|---|---|---|--|---|
| bottlebrush<br>( <i>Callistemon viminalis</i> )                             | chitalpa<br>( <i>X Chitalpa tashkentensis</i> ) | honey mesquite*<br>( <i>Prosopis glandulosa</i> ) | madrone/strawberry tree*<br>( <i>Arbutus</i> spp.)       | toyon*<br>( <i>Heteromeles arbutifolia</i> )      |
| Catalina cherry*<br>( <i>Prunus ilicifolia</i> spp. lyonii)                 | desert willow<br>( <i>Chilopsis linearis</i> )  | lemonade berry<br>( <i>Rhus integrifolia</i> )    | Olive (Fruitless)<br>( <i>Olea europaea</i> 'Swan Hill') | tree yuccas*<br>( <i>Yucca</i> spp.)              |
| Catalina ironwood*<br>( <i>Lyonothamnus floribundus</i> ssp. asplenifolius) | flannel bush*<br>( <i>Fremontodendron</i> spp.) | lilac chastetree<br>( <i>Vitex agnus-castus</i> ) | paloverde*<br>( <i>Parkinsonia</i> spp.)                 | western redbud*<br>( <i>Cercis occidentalis</i> ) |

\* California native plants

**811 Be Safe, Dig Safe.** Before you begin any landscaping work, always call 811 at least two business days in advance. With one free call to 811, PG&E will send a crew that can mark our underground gas and electric facilities before you begin work, helping you plan a safe project.

The above list includes water-wise plants suited for most California climate zones, however each location is different. PG&E makes no representation or guarantee that these plants are suitable for every location. Please consult your local nursery for more information. If there is an electric powerline on or near your property, there may be additional land use restrictions. Please take care to consult any easement agreement you may have for your property or call PG&E at 1-877-259-8314.

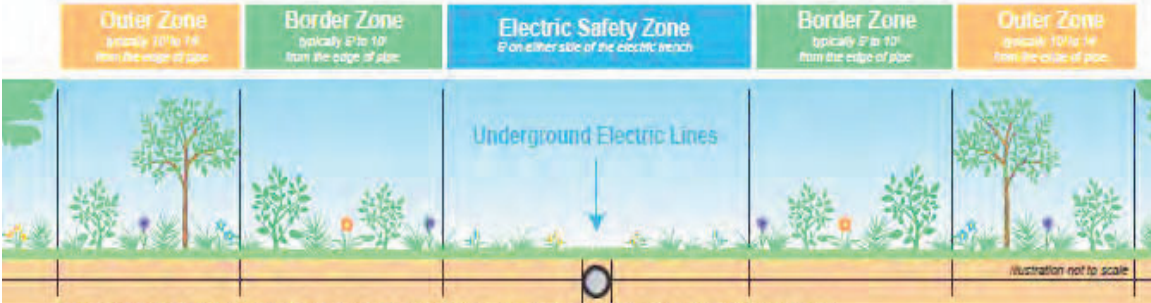
PG&E is a subsidiary of PG&E Corporation. ©2016 Pacific Gas and Electric Company. All rights reserved. CG-0615-0101

cited in Cal. Rest. Ass'n v. City of Berkeley  
No. 21-16278am archived December 27, 2023



## Guide to Safe Landscaping Near Underground Electric Lines

When planning new landscaping near underground utilities, it's important to remember that the right plant in the right location can both enhance the natural beauty of your home or business and help protect your community. Trees and plants located too close to underground electric lines can delay emergency access for safety crews and damage lines. Below is a list of ultra-drought tolerant plant types that are safe in certain locations around the electric lines. Please note the suggested list is not all-inclusive.



Please note easement widths can vary and the above represents best practices and guidance for safe landscaping near underground electric lines.

- |   |   |  |  |   |
|---|---|--|--|---|
| <b>Electric Safety Zone</b>   |   |  |  |   |
| Lawns, flowers, low-profile grasses and low-growing herbaceous plants are permitted within the electric Safety Zone. See the list below for plant suggestions.  |   |  |  |   |
| azure penstemon*<br>( <i>Penstemon azureus</i> )  | California poppy*<br>( <i>Esochscholzia californica</i> ) | grama grass*<br>( <i>Bouteloua</i> spp.)               | purple needle grass*<br>( <i>Stipa pulchra</i> )         | stonecrop* (Sedum spp.)   |
| belladonna lily<br>( <i>Amaryllis belladonna</i> )  | chalk lettuce<br>( <i>Dudleya</i> spp.)                   | June grass*<br>( <i>Koeleria macrantha</i> )           | sea lavender*<br>( <i>Limonium</i> spp.)                 | thyme* ( <i>Thymus</i> spp.)                                      |
| blue eyed grass*<br>( <i>Sisyrinchium bellum</i> )  | daffodil<br>( <i>Narcissus</i> spp.)                      | kangaroo paw<br>( <i>Aniropsis</i> spp.)               | showy milkweed*<br>( <i>Asclepias speciosa</i> )         | UC Verde buffalograss<br>( <i>Buohioe daotyloides</i> 'UC Verde') |
| Bulbine<br>( <i>Calyptophus</i> spp.)   | dymondia<br>( <i>Dymondia margaritae</i> )                | Monardella<br>( <i>Monardella</i> spp.)                | silverbush<br>( <i>Convolvulus cheorum</i> )             | yarrow* ( <i>Achillea</i> spp.)                                   |
| <b>Border Zone</b>  |   |  |  |   |
| Small to medium shrubs with a trunk or main branch less than 8" in diameter at full maturity are permitted within the Border Zone. Diameter is measured at chest height. See the list below for plant suggestions.  |   |  |  |   |
| Adam's needle<br>( <i>Yucca filamentosa</i> )   | California fuchsia*<br>( <i>Epilobium canum</i> )         | coyote brush*<br>( <i>Baccharis pilularis</i> )        | pipestem clematis*<br>( <i>Clematis lasiantha</i> )      | silver bush lupine*<br>( <i>Lupinus albus</i> )                   |
| agave*<br>( <i>Agave</i> spp.)  | California lilac*<br>( <i>Ceanothus</i> spp.)             | island tree poppy*<br>( <i>Dendromecon</i> spp.)       | rockrose*<br>( <i>Cistus</i> spp.)                       | sticky monkey flower*<br>( <i>Mimulus aurantiacus</i> )           |
| bear grass<br>( <i>Nolina microcarpa</i> )  | California native sage*<br>( <i>Salvia</i> spp.)          | manzanita*<br>( <i>Arcostaphylos</i> spp.)             | sacaton*<br>( <i>Sporobolus</i> spp.)                    | westringia<br>( <i>Westringia</i> spp.)                           |
| buckwheat*<br>( <i>Erigeron</i> spp.)   | California sagebrush*<br>( <i>Artemisia</i> spp.)         | matilija poppy*<br>( <i>Romneya coulteri</i> )         | smoke tree<br>( <i>Cotinus oogygia</i> )                 | wild rye grass*<br>( <i>Leymus</i> spp.)                          |
| bush anemone*<br>( <i>Carpenteria californica</i> )   | coffeeberry*<br>( <i>Rhamnus californica</i> )            | mountain mahogany<br>( <i>Cercocarpus betuloides</i> ) | snowberry*<br>( <i>Symphoricarpos</i> spp.)              | wooly blue curls*<br>( <i>Trichostema lanatum</i> )               |
| <b>Outer Zone</b>   |   |  |  |   |
| Large shrubs and small trees with a trunk less than 38" in diameter at full maturity are permitted within the Outer Zone; however, if space allows, we recommend planting trees at an even greater distance from the electric lines. Diameter is measured at chest height. See the list below for small tree suggestions. |   |  |  |   |
| bottlebrush<br>( <i>Callistemon viminalis</i> )   | chitalpa<br>( <i>X Chitalpa tashkentensis</i> )           | honey mesquite*<br>( <i>Prosopis glandulosa</i> )      | madrone/strawberry tree*<br>( <i>Arbutus</i> spp.)       | toyon*<br>( <i>Heteromeles arbutifolia</i> )                      |
| Catalina cherry*<br>( <i>Prunus ilioifolia</i> spp. <i>lyonii</i> )   | desert willow<br>( <i>Chilopsis linearis</i> )            | lemonade berry<br>( <i>Rhus integrifolia</i> )         | Olive (Fruitless)<br>( <i>Olea europaea</i> 'Swan Hill') | tree yuccas*<br>( <i>Yucca</i> spp.)                              |
| Catalina ironwood*<br>( <i>Lyonothamnus floribundus</i> ssp. <i>asplenifolius</i> )   | flannel bush*<br>( <i>Fremontodendron</i> spp.)           | lilac chasteberry<br>( <i>Vitex agnus-castus</i> )     | paloverde*<br>( <i>Parkinsonia</i> spp.)                 | western redbud*<br>( <i>Cercis occidentalis</i> )                 |

\* California native plants



### Be Safe. Dig Safe.

Before you begin any landscaping work, always call 811 at least two business days in advance. With one free call to 811, PG&E will send a crew that can mark our underground gas and electric facilities before you begin work, helping you plan a safe project.

The above list includes water-wise plants suited for most California climate zones, however each location is different. PG&E makes no representation or guarantee that these plants are suitable for every location. Please consult your local nursery for more information. If there is an electric powerline on or near your property, there may be additional land use restrictions. Please take care to consult any easement agreement you may have for your property or call PG&E at 1-877-259-8314.



cited in Cal. Rest. Ass'n v. City of Berkeley  
No. 21-16278am archived December 27, 2023

## ■ Tree Planting Matrix Tables

Applicants should not plant trees either under or adjacent to power lines. If applicants decide to plant trees or shrubs on their properties, attached is a list of low-growing, fire-resistant vegetation to consider for ground cover near facilities.

Table B-1 through Table B-6 list trees that are suitable for planting near (not adjacent to or under) power lines. The trees are listed by genus and species in each table. The list is limited and does not include all suitable trees; however, applicants can use this information as a guideline for choosing an appropriate tree for planting near power lines. The basic rule of thumb is to choose plants that grow to be 2 feet or less at maturity. For additional suggestions about appropriate trees, consult with nurseries, certified arborists, gardening books, and websites like [SelectTree](http://ecologycenter.org/directory/directory-entries/selectree/) at <http://ecologycenter.org/directory/directory-entries/selectree/> (maintained by the Urban Forest Ecosystems Institute at Cal Poly State University, San Luis Obispo).

PG E urges applicants to consider planting shrubs, grasses, and flowers near and under power lines. By selecting low-growing vegetation, applicants ensure that trimming back intrusive growth is not an issue.

*cited in Cal. Rest. Ass'n v. City of Berkeley  
No. 21-16278am archived December 27, 2023*

Table -1 Plant Matrix for Stockton, Yosemite, Fresno, and Kern Divisions<sup>1</sup>

Botanical Name Genus and Species	Common Name	Evergreen vs. Deciduous	Height and Spread (in feet)	Drought Tolerant	Special Considerations	Climate Zones <sup>2</sup>
<i>Acer buergerianum</i>	Trident Maple	D	25 s	No	Low spreading growth, red to yellow fall color.	4-9, 14-16, 20, 21
<i>Acer palmatum</i>	Japanese Maple	D	25 h	No	Green leaf varieties tolerate sun best, fire resistance favorable.	1-9, 14-24
<i>Cercis canadensis</i>	Eastern Redbud	D	25-40 h <sup>3</sup>	No	Small rosy pink flowers in early spring, is easily killed by over-watering.	1-3, 7-20
<i>Cotinus coggygria</i> 'prupurea'	Smoke Tree	D	25 h	—	Branches droop but resist breakage, full sun, dramatic puffs of purple to lavender from fading flowers.	1-24
<i>Crataegus laevigata</i>	English Hawthorn	D	25 h 15 s	—	Thorny branches, need pruning to thin out excess twiggy growth, bright rose to red flowers.	1-11, 14-17
<i>Koelreuteria paniculata</i> 'Kew' or 'Fastigiata'	Golden Rain Tree	D	25 h	No	Branches susceptible to breakage, soil should be well drained, prune to shape.	2-21
<i>Lagerstroemia x faueri</i> cultivars with Indian names	Crape Myrtle (cultivar mentioned w/ Indian names are resistant to powdery mildew)	D	25 h 25 s	Yes	Attracts birds, plant in full sun, various flower colors available, white, red, pink, purple.	7-9, 12-14, 18-21
<i>Laurus saratoga</i>	Saratoga Laurel	E	25 h	—	Compact erect tree, takes pruning well, needs good drainage.	5-9, 12-24
<i>Pittosporum tobira</i>	Tobira	E	15 h	Yes	Small tree. Rarely grows to 30 feet, favorable fire resistance, takes pruning well, full sun or partial shade, clusters of creamy white flowers in spring.	8-24
<i>Prunus cerasifera</i> 'krauter vesuvius' 'thundercloud' and 'newport'	Flowering Plum	E	18 h 12 s	—	Profuse fragrant pink flowers early spring, leaves purple/black, no or little fruit, several cultivars to choose from.	2-22
<i>Syringa reticulata</i>	Japanese Tree Lilac	D	30 h <sup>3</sup>	—	Large shrub easily trained as single-stemmed tree, useful as small shade and street tree, showy white flowers in spring.	1-12, 14-16

<sup>1</sup> Plant Matrix for Stockton Division (Amador, Calaveras, San Joaquin, Alpine) (Zones 7, 8, 9, 14), Yosemite Division (Stanislaus, Merced, Tuolumne, Mariposa, Madera) (Zones 1, 7, 8, 9), Fresno Division (Fresno, Kings) (Zones 1, 7, 8, 9) and Kern Division (Kern) (Zones 1, 2, 7, 8, 9).

<sup>2</sup> Refer to the climate zone map in *Sunset Western Garden Book* for the climate zone in your area.

<sup>3</sup> Trees referenced as growing to 30 feet (or more) at maturity generally do not reach their maximum height except under optimum growing conditions.

## Appendix B: Electric and Gas Service Documents

Table -2 Plant Matrix for San Francisco, Peninsula, and De Anza Divisions<sup>1</sup>

Botanical Name Genus and Species	Common Name	Evergreen vs. Deciduous	Height and Spread (in feet)	Drought Tolerant	Special Considerations	Climate Zones <sup>2</sup>
<i>Acer griseum</i>	Paperbark Maple	D	25 h	No	Late to leaf out in spring, narrow rounded crown, brilliant red fall color.	1-9, 14-21
<i>Arbutus unedo</i>	Strawberry Tree	E	35 h <sup>3</sup>	—	Rarely exceeds 15-20 feet in coastal areas, fire resistance favorable, hanging pink/red flowers, fruit looks similar to strawberries.	4-24
<i>Cercis occidentalis</i>	Western Redbud	D	25 h	Yes	California native, attractive changing flower and foliage color, is easily killed by over-watering.	2-24
<i>Crateagus lavallei</i>	Carriere Hawthorn	D	25 h 15-20 s	—	Dark green leaves, turn bronze red after sharp frost, white flowers in spring, red and orange fruit can be messy on walkways.	1-11, 14-17
<i>Eriobotrya deflexa</i> 'coppertone'	Bronze Loquat	E	25 h 25 s	No	Shrubby, easily trained to a tree, new growth is copper for long time before turning green.	8-24
<i>Garrya elliptica</i>	Coast Silkassel	E	25 h	Yes	California native, fire resistance favorable graceful yellowish/green catkins 3-inches to 8-inches long on males.	5-9, 14-21
<i>Koeleruteria paniculata</i> 'Kew' or 'Fastigiata'	Golden Rain Tree	D	25 h	No	Branches susceptible to breakage, soil should be well drained, prune to shape.	2-21
<i>Leptospermum laevigatum</i>	Australian Tea Tree	E	30 h <sup>3</sup> 30 s	Yes	Grows best near the coast, flowers in spring, needs full sun, it is quite frost sensitive.	14-24
<i>Rhus lancea</i>	Amur Sumac	E	25 h 20 s	Yes	Slow growing, takes high summer heat. Can be multi-stemmed or trained to one stem tree. Good screen.	8, 9, 12-24
<i>Prunus cerasifera</i> 'krauter vesuvius' 'thundercloud' and 'newport'	Flowering Plum	E	18 h 12 s	—	Profuse fragrant pink flowers early spring, leaves purple/black, no or little fruit, several cultivars to choose from.	2-22
<i>Prunus serrulata</i> 'Kwanzan'	Flowering Cherry	D	25 h	—	Spectacular spring flowers, needs moist protected site, good soil drainage and full sun.	2-7, 14-20

<sup>1</sup> Plant Matrix for San Francisco Division (San Francisco) (Zone 17), Peninsula Division (San Mateo) (Zones 14, 15, 16, 17) and De Anza Division (Santa Clara) (Zones 15, 16, 17).

<sup>2</sup> Refer to the climate zone map in *Sunset Western Garden Book* for the climate zone in your area.

<sup>3</sup> Trees referenced as growing to 30 feet (or more) at maturity generally do not reach their maximum height except under optimum growing conditions.

Table - Plant Matrix for San Jose, Central Coast, and Los Padres Divisions <sup>1</sup>

Botanical Name Genus and Species	Common Name	Evergreen vs. Deciduous	Height and Spread (in feet)	Drought Tolerant	Special Considerations	Climate Zones <sup>2</sup>
<i>Acer griseum</i>	Paperbark Maple	D	25 h	No	Late to leaf out in spring, narrow rounded crown, brilliant red fall color.	1-9, 14-21
<i>Crateagus phaenopyrum</i>	Washington Thorn	D	25 h 20 s	—	Orange red fall foliage, shiny red fruit, light open limb structure, least susceptible to fireblight.	1-11, 14-17
<i>Eriobotrya deflexa</i> 'coppertone'	Bronze Loquat	E	25 h	No	Shrubby, easily trained to a tree, new growth is copper for long time before turning green.	8-24
<i>Laurus saratoga</i>	Saratoga Laurel	E	25 h	—	Compact erect tree, takes pruning well, needs good drainage.	5-9, 12-24
<i>Ligustrum ovalifolium</i>	California Privet	semi-deciduous	15 h	—	Inexpensive hedge plant, takes pruning well.	4-24
<i>Malus floribunda</i> 'adams', 'robinson'	Crabapple	D	25 h 30 s	—	Attracts birds and bees, good disease resistance, <i>several cultivars to choose from.</i>	1-11, 14-21
<i>Myoporum insulare</i>	Myoporum	E	30 h <sup>3</sup> 20 s	—	Fire resistant, takes full sun, it is quite frost sensitive.	8, 9, 15-17, 19-24
<i>Myrica californica</i>	Pacific Wax-myrtle	E	25 h	Yes	California native, fire resistance favorable.	4, 5, 6, 14-17, 20-24
<i>Olea europaea</i> 'Swan Hill'	Fruitless Olive	E	30 h <sup>3</sup> 25 s	—	Does well in areas with hot dry summers, full sun, withstands heavy pruning.	8, 9, 11-24
<i>Pittosporum tobira</i>	Tobira	E	25 h	yes	Small tree. Rarely grows to 30 feet, favorable fire resistance, takes pruning well, full sun or partial shade, clusters of creamy white flowers in spring.	8-17, 19-24
<i>Prunus cerasifera</i> 'krauter vesuvius' 'thundercloud' and 'newport'	Flowering Plum	E	18 h 12 s	—	Profuse fragrant pink flowers early spring, leaves purple/black, no or little fruit, <i>several cultivars to choose from.</i>	2-22
<i>Tristania laurina</i> 'Elegans'	Elegant Brisbane Box	E	25 h	No	Can be trained to be a single or multi-stemmed trunk, excellent for screen and boundary planting.	15-18, 19-24

<sup>1</sup> Plant Matrix for San Jose Division (Santa Clara) (Zones 15, 16, 17), Central Cost Division (Santa Cruz, San Benito, Monterey) (Zones 7, 14, 15, 16, 17) and Los Padres Division (San Luis Obispo, Santa Barbara) (Zones 2, 3, 7, 14, 15, 16, 17, 18, 23, 24).

<sup>2</sup> Refer to the climate zone map in *Sunset Western Garden Book* for the climate zone in your area.

<sup>3</sup> Trees referenced as growing to 30 feet (or more) at maturity generally do not reach their maximum height except under optimum growing conditions.

## Appendix B: Electric and Gas Service Documents

Table - Plant Matrix for North Valley, Sierra, and Sacramento Divisions<sup>1</sup>

Botanical Name Genus and Species	Common Name	Evergreen vs. Deciduous	Height and Spread (in feet)	Drought Tolerant	Special Considerations	Climate Zones <sup>2</sup>
<i>Acer ginnala</i>	Amur Maple	D	25 h	No	Multi-trunk large shrub or trained at nursery as one stem tree, striking red fall color.	1-9, 14-16
<i>Acer palmatum</i>	Japanese Maple	D	25 h	No	Green leaf varieties tolerate sun best, fire resistance favorable.	1-9, 14-24
<i>Cercocarpus ledifolius</i>	Curly Leaf Mountain Mahogany	E	20 h	Yes	Native to dry mountain slopes, attractive open branching pattern, OK in full sun.	1-3, 7-14, 18, 19
<i>Cornus kousa</i>	Kousa Dogwood	D	25 h	No	Needs ample water, big multi-stem shrub can be trained to a tree, white flowers.	3-9, 14, 15, 18, 19
<i>Crateagus phaenopyrum</i>	Washington Thorn	D	25 h 20 s	—	Orange red fall foliage, shiny red fruit, light open limb structure, least susceptible to fireblight.	1-11, 14-17
<i>Garrya elliptica</i>	Coast Silktassel	E	25 h	Yes	California native, fire resistance favorable, graceful yellowish/green catkins 3-inches to 8-inches long on males.	5-9, 14-21
<i>Lagerstroemia x faueri</i> cultivars with Indian names	Crape Myrtle (cultivar mentioned w/ Indian names are resistant to powdery mildew)	D	25 h 25 s	Yes	Attracts birds, plant in full sun, various flower colors available, white, red, pink, purple.	7-9, 12-14, 18-21
<i>Laurus saratoga</i>	Saratoga Laurel	E	25 h	—	Compact erect tree, takes pruning well, needs good drainage.	5-9, 12-24
<i>Sorbus aucuparia</i>	European Mountain Ash	E	30 h <sup>3</sup> 20 s	—	Stands winter cold, strong winds, low humidity and extreme heat, attractive to birds, bright fruit, clustered white flowers.	1-10, 14-17
<i>Styrax japonica</i>	Japanese Snowdrop Tree, Japanese Snowbell	D	30 h <sup>3</sup>	No	Needs well drained soil, full sun or part shade, plenty of water. Prune to control shape, tends to be shrubby if lower branches left.	3-10, 14-21
<i>Syringa reticulata</i>	Japanese Tree Lilac	D	30 h <sup>3</sup>	—	Large shrub easily trained as single-stemmed tree, useful as small shade and street tree, white showy flowers in spring.	1-12, 14-16

<sup>1</sup> Plant Matrix for North Valley Division (Shasta, Tehama, Glenn, Butte) (Zones 1, 7, 8, 9), Sierra Division (Sutter, Yuba, Nevada, Sierra, Placer, El Dorado) (Zones 1, 7, 8, 9) and Sacramento Division (Yolo, Colusa, Solano) (Zones 7, 8, 9, 14).

<sup>2</sup> Refer to the climate zone map in *Sunset Western Garden Book* for the climate zone in your area.

<sup>3</sup> Trees referenced as growing to 30 feet (or more) at maturity generally do not reach their maximum height except under optimum growing conditions.

Table - Plant Matrix for Diablo, Mission, and East Bay Divisions <sup>1</sup>

Botanical Name Genus and Species	Common Name	Evergreen vs. Deciduous	Height and Spread (in feet)	Drought Tolerant	Special Considerations	Climate Zones <sup>2</sup>
<i>Aesculus californica</i>	California Buckeye	D	25 h needs room, very wide spreading	Yes	California native, grows best in cool, coastal foothills.	4-7, 14-19
<i>Acer truncatum</i>	"Truncatum" Maple	D	20 h	No	Adaptable tree, leaves are purplish red, summer green, dark purple in autumn.	1-9, 14-23
<i>Cercis canadensis</i>	Eastern Redbud	D	25-35 h <sup>3</sup>	No	Small rosy pink flowers in early spring, is easily killed by over-watering.	1-3, 7-20
<i>Crateagus phaenopyrum</i>	Washington Thorn	D	25 h 20 s	—	Orange red fall foliage, shiny red fruit, light open limb structure, least susceptible to fireblight.	1-11, 14-17
<i>Laurus saratoga</i>	Saratoga Laurel	E	25 h	—	Compact erect tree, takes pruning well, needs good drainage.	5-9, 12-24
<i>Ligustrum ovalifolium</i>	California Privet	semi- deciduous	15 h	—	Inexpensive hedge plant, takes pruning well.	4-24
<i>Magnolia stellata</i>	Star Magnolia	D	10 h 20 s	No	Profuse bloom in late winter, early spring.	1-9, 14-24
<i>Malus floribunda</i> 'adams', 'robinson'	Crabapple	D	25 h 30 s	—	Attracts birds and bees, good disease resistance, several cultivars to choose from.	1-11, 14-21
<i>Prunus cerasifera</i> 'krauter vesuvius' 'thundercloud' and 'newport'	Flowering Plum	E	18 h 12 s	—	Profuse fragrant pink flowers early spring, leaves purple/black, no or little fruit, several cultivars to choose from.	2-22
<i>Prunus serrulata</i> 'Kwanzan'	Flowering Cherry	D	25 h	—	Spectacular spring flowers, needs moist protected site, good soil drainage and full sun.	2-7, 14-20
<i>Styrax japonica</i>	Japanese Snowdrop Tree, Japanese Snowbell	D	30 h <sup>3</sup>	No	Needs well-drained soil, full sun or part shade, plenty of water, prune to control shape, tends to be shrubby if lower branches left.	3-10, 14-21

<sup>1</sup> Plant Matrix for Diablo Division (Alameda, Contra Costa) (Zones 15, 16, 17), Mission Division (Alameda) (Zones 7, 14, 15) and East Bay Division (Contra Costa) (Zones 7, 14, 15, 16, 17).

<sup>2</sup> Refer to the climate zone map in *Sunset Western Garden Book* for the climate zone in your area.

<sup>3</sup> Trees referenced as growing to 30 feet (or more) at maturity generally do not reach their maximum height except under optimum growing conditions.

Appendix B: Electric and Gas Service Documents

Table B-1 Plant Matrix for North Coast and North Bay Divisions <sup>1</sup>

Botanical Name Genus and Species	Common Name	Evergreen vs. Deciduous	Height and Spread (in feet)	Drought Tolerant	Special Considerations	Climate Zones <sup>2</sup>
<i>Acer truncatum</i>	"Truncatum" Maple	D	20 h	No	Adaptable tree, leaves are purplish red, summer green, dark purple in autumn.	1-9, 14-23
<i>Aesculus californica</i>	California Buckeye	D	25 h needs room, very wide spreading	Yes	California native, grows best in cool, coastal foothills.	4-7, 14-19
<i>Amelanchier alnifolia</i>	Mountain Serviceberry	D	20 h	—	Suited to mountainous parts of the west, attractive foliage changes color.	1-6, 15, 16, 17
<i>Callistemon citrinus</i>	Lemon Bottlebrush	E	25 h	Yes	Favorable fire resistance, attracts hummingbirds, shrub easily trained to a tree, it is quite frost sensitive.	8, 9, 12-24
<i>Cercis occidentalis</i>	Western Redbud	D	25 h	Yes	California native, attractive changing flower and foliage color, is easily killed by over watering.	2-24
<i>Cotinus coggygria</i> <i>'purpurea'</i>	Smoke Tree	D	25 h	—	Branches droop but resist breakage, full sun, dramatic puffs of purple to lavender from fading flowers.	1-24
<i>Crataegus laevigata</i>	English Hawthorn	D	25 h 15 s	—	Thorny branches, need pruning to thin out excess twiggy growth, bright rose to red flowers.	1-11, 14-17
<i>Eriobotrya deflexa</i> <i>'coppertone'</i>	Bronze Loquat	E	25 h	No	Shrubby, easily trained to a tree, new growth is copper for long time before turning green.	8-24
<i>Leptospermum laevigatum</i>	Australian Tea Tree	E	30 h <sup>3</sup> 30 s	Yes	Grows best near the coast, flowers in spring, needs full sun, it is quite frost sensitive.	14-24
<i>Myoporum insulare</i>	Myoporum	E	30 h <sup>3</sup> 20 s	—	Fire resistant, takes full sun, tough, fast growing, it is quite frost sensitive.	8, 9, 15-17, 19-24
<i>Styrax japonica</i>	Japanese Snowdrop Tree, Japanese Snowbell	D	30 h <sup>3</sup>	No	Needs well-drained soil, full sun or part shade, plenty of water, prune to control shape, tends to be shrubby if lower branches left.	3-10, 14-21

<sup>1</sup> Plant Matrix for North Coast (counties Humboldt, Mendocino, Lake, Sonoma) (Zones 1, 2, 14, 15, 17) and North Bay Division (counties Napa, Marin) (Zones 7, 14, 15, 16, 17).

<sup>2</sup> Refer to the climate zone map in *Sunset Western Garden Book* for the climate zone in your area.

<sup>3</sup> Trees referenced as growing to 30 feet (or more) at maturity generally do not reach their maximum height except under optimum growing conditions.

PG&E-Prohibited Trees

Applicants must not plant the trees listed in Table B-1, "Do not Plant These Trees Under or Within 1 Feet of Overhead Power Lines," under or within 1 feet of overhead power lines. When mature, these trees affect PG&E's ability to provide and maintain safe and reliable service. Many species of trees are not appropriate for confined spaces under electric lines, although they may be appropriate for other locations within a development or building site. The list is limited and does not include all varieties of unsuitable trees however, applicants can use this information as a guideline when choosing an appropriate tree for planting near power lines. Applicants should plant trees that grow higher than 2 feet at maturity at least 15 feet to the side of overhead power lines.



Under the botanical names of the trees, occasionally only the genus is listed. Applicants should not plant any types of trees within these genera under or within 15 feet of overhead power lines.

Table -7 Do Not Plant These Trees Under or Within 15 Feet of Overhead Power Lines

Botanical Name (Genus and species)	Common Name	Evergreen vs Deciduous	Height and Spread (in feet)	Special Considerations	Climate Zones <sup>1</sup>
<i>Acacia baileyana</i>	Bailey Acacia	—	30 h	Most commonly planted. Fast growing, short lived.	7-9, 13-24
<i>Acacia mellanoxylon</i>	Blackwood Acacia	—	40 h 20 s	Fast dense upright growth. Roots aggressive, lifts sidewalks, splits easily and suckers (grows from the roots).	8, 9, 13-24
<i>Acer macrophyllum</i>	Bigleaf Maple	D	30-95 h	Native to California foothills, too big for small gardens and streets.	4-17
<i>Acer negundo</i>	Box Elder	D	60 h	Fast growing, seeds readily, subject to breakage.	1-10, 12-24
<i>Acer rubrum</i>	Red Maple	D	40+ h 20+ s	Fast growing, red twigs, branchlets and buds.	1-9, 14-17
<i>Acer saccharinum</i>	Silver Maple	D	40-100 h equal spread	Fast growth, weak wood.	1-9, 12, 14-24
<i>Ailanthus altissima</i>	Tree of Heaven	D	50 h	Fast growing, suckers and self seeds.	All zones
<i>Alnus spp.</i>	Alder Trees	D	40-90 h	Relatively fast growing, invasive roots, several native California species.	Various
<i>Eucalyptus</i>	Eucalyptus	E	30-200 h	Fast growing, invasive roots, many species	8-24
<i>Fraxinus</i>	Ash Trees	D	35-80 h	Relatively fast growing.	
<i>Carya illinoensis</i>	Pecan Trees	D	40-70 h 70 s	Long tap root and leathery mature leaves.	8-9, 12-14, 18-20
<i>Catalpa spp.</i>	Catalpa	D	up to 70 h	Some litter from fallen flowers in summer and seed capsules in fall. Seldom develops dominant shoot without shaping.	All zones
<i>Juglans spp.</i>	Walnut Trees	D	30-100 h spreading	Various species, check <i>Sunset Western Garden Book</i> , English and Black Walnut notorious for hosting aphids, honeydew is inevitable.	Various
<i>Liriodendron tulipifera</i>	Tulip Tree	D	up to 80 h 40 s	Fast growing, straight columnar trunk. Spreading root system makes it hard to garden under.	1-12, 14-23
<i>Liquidambar styraciflua</i>	Sweetgum, Liquidambar	D	60 h 25 s	Moderate growth rate, upright, somewhat cone shaped, fruits are spiny balls that need raking in fall. Roots can be a nuisance in lawns or parking strips.	1-12, 14-24
<i>Metasequoia glyptostroboides</i>	Dawn Redwood	D	up to 90 h	Salt winds and hot sunlight cause foliage burn.	3-9, 14-24
<i>Phoenix Canariensis</i>	Canary Island Date Palm	Palm/E	60 h 50 s	Grows slowly until it forms trunk, then speeds up a little. Slow to develop new head after hard frost.	9, 12- 24

<sup>1</sup> Refer to the climate zone map in *Sunset Western Garden Book* for the climate zone in your area.

## Appendix B: Electric and Gas Service Documents

Table -7 Do Not Plant These Trees Under or Within 1 Feet of Overhead Power Lines, continued

Botanical Name (Genus and species)	Common Name	Evergreen vs. Deciduous	Height and Spread (in feet)	Special Considerations	Climate Zones <sup>1</sup>
<i>Pinus spp.</i>	Pine Trees	D	30-100 h wide spreading	Some faster growing than other species. Many varieties.	various
<i>Platanus acerifolia.</i>	London Plane, Sycamore	D	40-80 h 30-40 s	Fast growing. Subject to anthracnose (causing early continuous leaf fall)	2-24
<i>Populus nigra italica</i>	Lombardy Poplar	D	40-100 h	Fast growing, invasive roots systems, suckers profusely.	All Zones
<i>Populus trichocarpa</i>	Black Cottonwood	D	150-180 h wide spreading	Heavy limbed, wood is very brittle. Native along mountain streams and wet lowlands west of cascades, California to Alaska.	1-7
<i>Pseudotsuga Menziesii</i>	Douglas Fir	E	70-250 h	Can't be maintained at a reduced height without butchering the tree. Native to Northwest America as far south as Fresno County.	1-10, 14-17
<i>Quercus lobata</i>	Valley Oak	D	70 h up to 70 s	Native to California. Limbs often twisted, long drooping outer branches can sweep ground.	1-3,6-16, 18-21
<i>Quercus spp.</i>	Oak Trees	D	up to 80 h 70 s	Various species, check Sunset Western Garden Book.	Various
<i>Robinia pseudoacacia</i>	Black Locust	D	75 h	Fast growth. Wood is brittle, roots aggressive, plants of spread by suckers.	All zones
<i>Salix babylonica</i>	Weeping Willow	D	50 h 50 s	Fast growing. Invasive root systems and are difficult to garden under.	All zones
<i>Sequoia sempervirens</i>	Coast Redwood	E	90 h 30 s	World's tallest tree. Optimum conditions to 350f. Fast growing. Can defeat lawns.	4-9, 14-24
<i>Ulmus spp.</i>	Elm Trees	D	100 h 70 s	Various species, check <i>Sunset Western Garden Book</i> . Root systems are aggressive. Branch crotches often narrow, easily split, Attracts leaf beetles, bark beetles, leafhoppers, aphids and scale. Care can be messy.	Various
<i>Washingtonia filifera</i>	California Fan Palm	Palm/ E	60 h	Fast growing, native to California.	8,9,11-24
<i>Washingtonia robusta</i>	Mexican Fan Palm	Palm/E	100 h	Very fast growing.	8,9,11-24
<i>Zelkova serrata</i>	Sawleaf Zelkova	D	60+ h 60 s	Moderate to fast growth.	3-21

<sup>1</sup> Refer to the climate zone map in *Sunset Western Garden Book* for the climate zone in your area.

cited in Cal. Rest. Ass'n v. City of Berkeley  
No. 21-16278am archived December 27, 2023



## Backfill Sand

### Summary

This engineering material specification (EMS) defines the minimum requirements for imported sand used in bedding and embedment backfill around gas pipe in trenches.

This EMS is used for specifying this material in the contract procurement process, applicant design and installation, local maintenance and construction, and general construction.

### Target Audience

Personnel involved in sourcing, engineering, construction, and supplier quality inspection.

### Requirements

#### 1 General

- 1.1 Backfill sand (sand) can be well or poorly graded material as determined in ASTM D2487-11, "Standard Classification of Soils for Engineering Purposes (Unified Soil Classification System)."
- 1.2 Sand must be free of organic and harmful materials that could cause adverse environmental impact.
- 1.3 Do not use blasting abrasives containing toxic elements that are at or above hazardous waste levels defined in [Code of Federal Regulations \(CFR\) Title 40, Protection of Environment, Part 261—Identification and Listing of Hazardous Waste](#) or [California Code of Regulations](#).
- 1.4 Sand must conform to the physical properties listed in this EMS.
- 1.5 The responsible engineer may specify additional requirements for specific project needs.



## Backfill Sand

### 2 Grain Size Distribution Requirements

- 2.1 Sand must meet the soil gradation requirements listed in Table 1, "Grain Size Distribution Requirements," using ASTM C136-14, "Standard Test Method for Sieve Analysis of Fine and Coarse Aggregates."

**Table 1. Grain Size Distribution Requirements**

Sieve	Sieve Size		% Passing
3/8"	0.375 in.	9.5 mm	100
No. 4	0.187 in.	4.75 mm	90–100
No. 200	0.00298 in.	75 µm	0–15

### 3 pH Value

- 3.1 Value of pH must be between 4.5 and 9, using ASTM G51-95, "Standard Test Method for Measuring pH of Soil for Use in Corrosion Testing," or ASTM D4972-13, "Standard Test Method for pH of Soils."

### 4 Resistivity

- 4.1 Resistivity must be greater than 3000 ohm-cm, using ASTM G57-06(2012), "Standard Test Method for Field Measurement of Soil Resistivity Using the Wenner Four-Electrode Method," or ASTM G187-12a, "Standard Test Method for Measurement of Soil Resistivity Using the Two-Electrode Soil Box Method."

1. IF Resistivity is less than 3000 ohms-cm,

THEN the following chemical content limits apply:

- a. Total chloride content: equal to or less than 500 parts per million, as determined by EPA Method 300.0 prepared by Parr O2 bomb combustion.
- b. Total sulfate content: equal to or less than 150 parts per million, as determined by EPA Method 300.0 prepared by Parr O2 bomb combustion.

### 5 Maximum Dry Unit Weight and Optimum Moisture Content

- 5.1 Supplier must provide the maximum dry unit weight and optimum moisture content of sand determined by using the standard or modified Proctor test (ASTM D698-12 or ASTM D1557-12) or equivalent.



## Backfill Sand

### 6 Testing

6.1 Pacific Gas and Electric Company (PG&E) reserves the right to:

1. Request supplier to provide written documentation summarizing the test results and certify that the supplied sand meets the specifications in this EMS. The documentation must include the length of time for which the test results are valid (typically 12 months).
2. Request supplier to provide new test results when there is a change in the original approved source.
3. Obtain samples from the source for internal testing at any time.

### 7 Records

7.1 Retain records per the records retention schedule.

### END of Requirements

#### Definitions

**Soil Gradation:** Classification of a coarse-grained soil that ranks the soil based on the different particle sizes.

**pH:** Measurement of the acidity or alkalinity of a solution or material.

**Resistivity:** Measurement of how strongly a material opposes electrical current.

#### Compliance Requirement/Regulatory Commitment

[Code of Federal Regulations \(CFR\) Title 49, Transportation, Part 192—Transportation of Natural and other Gas by Pipeline: Minimum Federal Safety Standards, Section 192.319, "Installation of pipe in a ditch."](#)

[California Public Utilities Code, Article 3, Equipment, Practices, and Facilities, Section 787](#)

*Noted in Cal. Rest. Ass'n v. City of Berkeley No. 21-16278am archived December 27, 2023*



## Backfill Sand

### Reference Documents

#### Developmental References:

American Association of State Highway and Transportation Officials (AASHTO) M 145, "Soil Classification System".

A.W. Peabody, *Control of Pipeline Corrosion*, Second Edition (National Association of Corrosion, 2001)

[California Department of Transportation \(Caltrans\) Corrosion Guidelines](#)

[Caltrans 2015 Standard Specifications](#)

[United States Bureau of Reclamation \(USBR\) Earth Manual Part 1, Third Edition, 1998](#)

#### Supplemental References:

ASTM C136-14, "Standard Test Method for Sieve Analysis of Fine and Coarse Aggregates"

ASTM D698-12, "Standard Test Methods for Laboratory Compaction Characteristics of Soil Using Standard Effort"

ASTM D1557-12, "Standard Test Methods for Laboratory Compaction Characteristics of Soil Using Modified Effort"

ASTM D2487-11, "Standard Classification of Soils for Engineering Purposes (Unified Soil Classification System)"

ASTM D4972-13, "Standard Test Method for pH of Soils"

ASTM G51-95, "Standard Test Method for Measuring pH of Soil for Use in Corrosion Testing"

ASTM G57-06(2012), "Standard Test Method for Field Measurement of Soil Resistivity Using the Wenner Four-Electrode Method"

ASTM G187-12a, "Standard Test Method for Measurement of Soil Resistivity Using the Two-Electrode Soil Box Method"

### Appendices

NA



## Backfill Sand

### Attachments

NA

### Document Revision

EMS-4123, "Backfill Sand," Rev. 0

### Approved By

Jerrod Meier, Manager, Gas Standards and Procedures

### Document Owner

Sean Mann, Senior Gas Standards Engineer, Gas Standards and Procedures - Engineering & Design

### Document Contact

Sean Mann, Senior Gas Standards Engineer, Gas Standards and Procedures - Engineering & Design

### Revision Notes

Where?	What Changed?
Revision 1a	
Section 7	Added section, including records retention statement.
Revision 1	
Entire Document	Updated entire document to current EMS template.
Section 2	Updated gradation requirements.
Section 3	Removed organic impurities requirement.
Section 3	Removed sand equivalency requirement.
Section 3	Removed "Coefficient of Uniformity" requirement.
Section 4	Updated resistivity requirements.
Section 5	Updated maximum dry unit weight and optimum moisture content.
Section 6	Updated testing requirements.

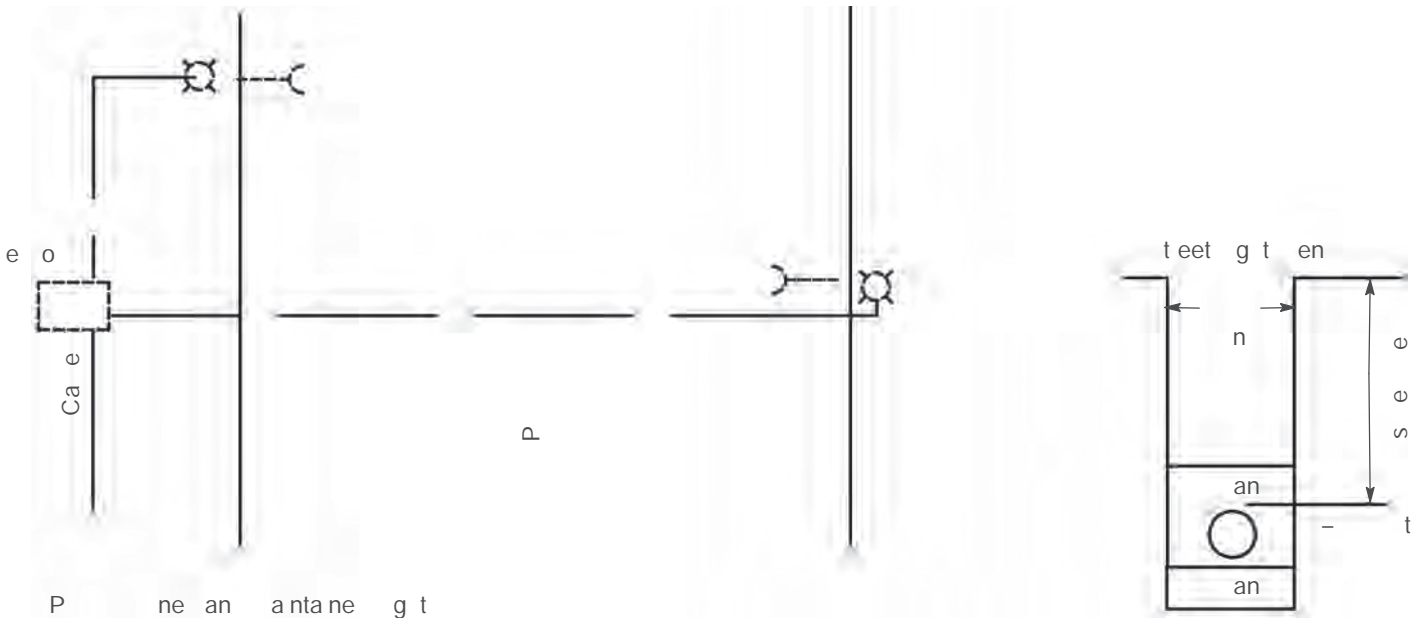
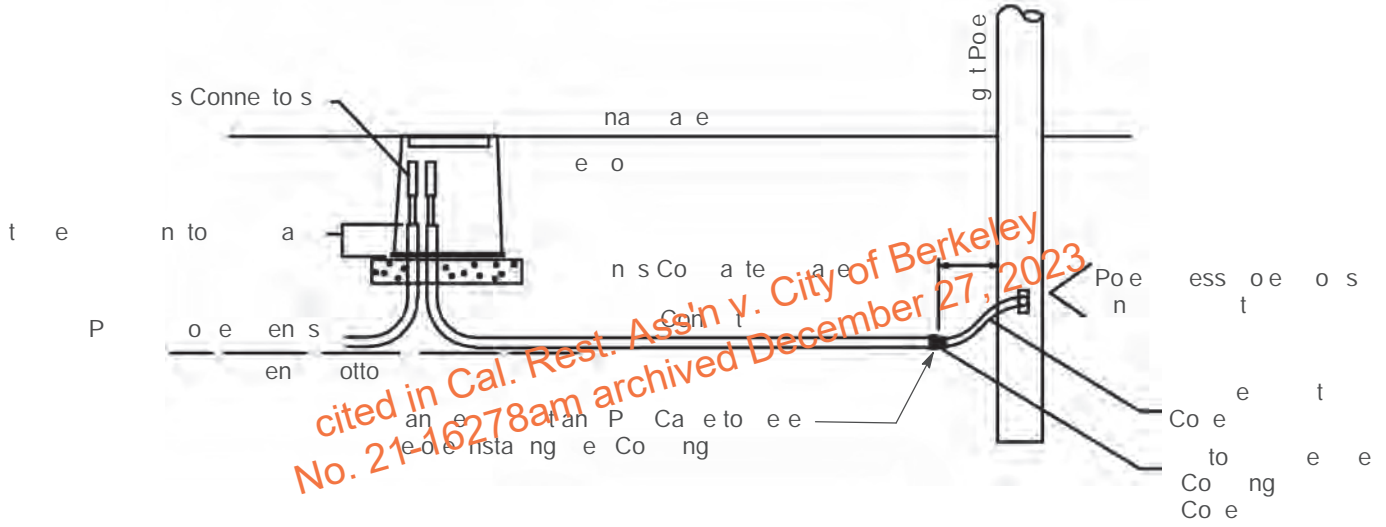
*cited in Cal. Rest. Ass'n v. City of Berkeley  
 No. 21-16278am archived December 27, 2023*



cited in Cal. Rest. Ass'n v. City of Berkeley  
No. 21-16278am archived December 27, 2023

### Street Light Conduit Detail

Notes: This detail is for use in areas where the installation of a street light is required. The conduit shall be installed in a trench at least 18 inches deep. The conduit shall be supported by concrete or masonry blocks. The conduit shall be secured to the blocks with wire ties. The conduit shall be terminated in a street light fixture. The conduit shall be labeled with the name of the street light fixture. The conduit shall be installed in a trench at least 18 inches deep. The conduit shall be supported by concrete or masonry blocks. The conduit shall be secured to the blocks with wire ties. The conduit shall be terminated in a street light fixture. The conduit shall be labeled with the name of the street light fixture.



cited in Cal. Rest. Ass'n v. City of Berkeley  
No. 21-16278am archived December 27, 2023

**TYPICAL DISTRIBUTION TRENCH**

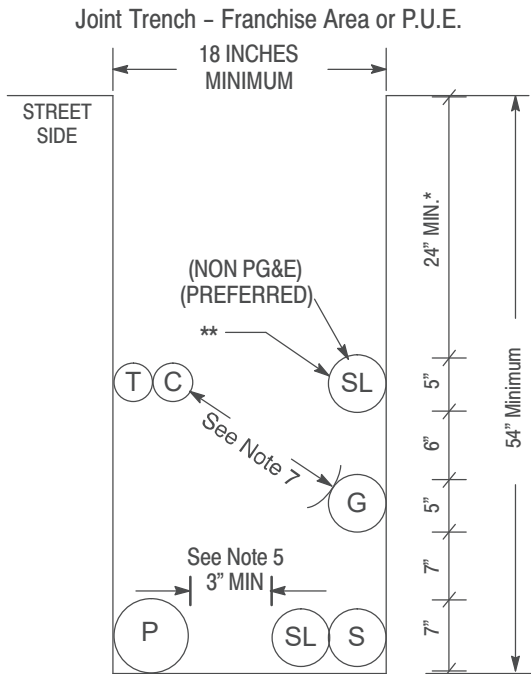


FIG. 1

Placement of the Distribution Trench within a P.U.E. is the preferred method. Trenching in the Franchise Area should only be used when a P.U.E. is unobtainable or otherwise infeasible.

\* Increase cover to 30" in the street area (see Note 3).

\*\* Separation must be 12" unless a reduction (6") is mutually agreed upon by affected utilities.

**TYPICAL SERVICE TRENCH**

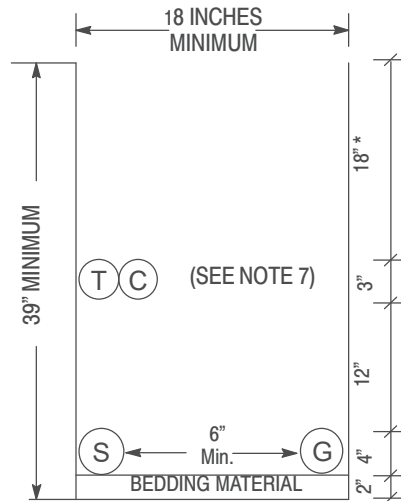


FIG. 2  
(View facing Distribution Trench)

**MINIMUM SEPARATION AND CLEARANCE REQUIREMENTS**

		G	DUCT T	DB T	C	S	P
G	(GAS) SEE NOTES 4, 7 & 13	—	12"	12"	12"	6"	12"
T	(TELEPHONE) DUCT	12"	—	1"	1"	12"	12"
T	(TELEPHONE) DIRECT BURY	12"	1"	—	1"	12"	12"
C	(CATV)	12"	1"	1"	—	12"	12"
S	(ELECTRIC SECONDARY)	6"	12"	12"	12"	—	3"
P	(ELECTRIC PRIMARY)	12"	12"	12"	12"	3"	—
SL	(STREETLIGHT) SEE NOTE 5	6"	12"	12"	12"	1"	3"

**SEPARATION AND CLEARANCE DEFINITIONS**

**Cover:**

The term "cover" means the radial distance between the surface of an underground cable, conduit, pipe, or other substructure and the surface elevation (grade).

**Backfill:**

The term "backfill" refers to the materials used to refill a cut or other excavation, or the act of such refilling after any needed shading is performed.

**Shading:**

The term "shading" refers to the materials used to provide a measure of separation between facilities installed at different levels within an excavation or cut.

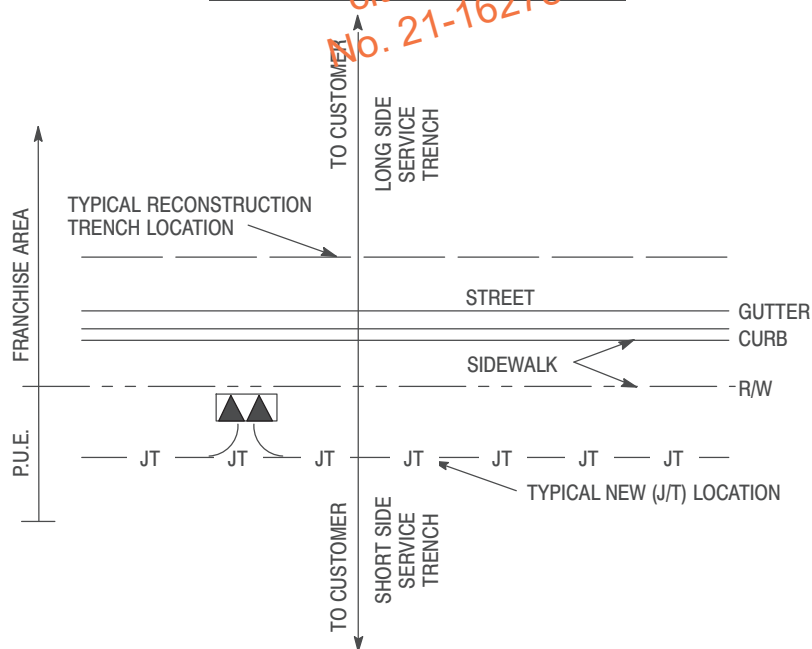
**Lift:**

The term "lift" is a layer of fill as spread or as compacted or a measurement of material depth that is the rated effective soil depth a compactor can achieve.

**Bedding:**

The term "bedding" refers to the materials installed beneath facilities at the bottom of a cut or other excavation and intended to provide support and/or protection for those facilities.

**STANDARD TRENCH LOCATIONS**



**JOINT TRENCH CONFIGURATIONS & OCCUPANCY GUIDE**

09-27-06

## OTHER TYPICAL PG&E DISTRIBUTION JOINT TRENCH CONFIGURATIONS

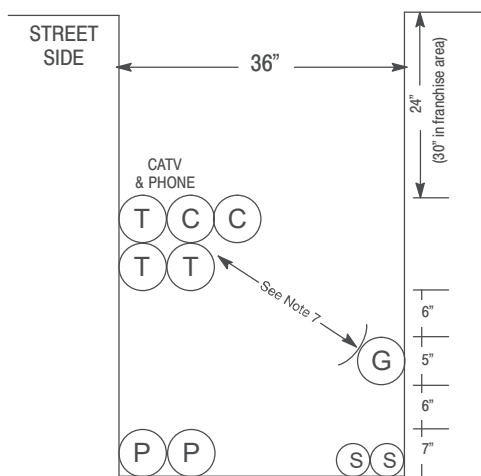


FIG. 3  
36" Wide Joint Trench

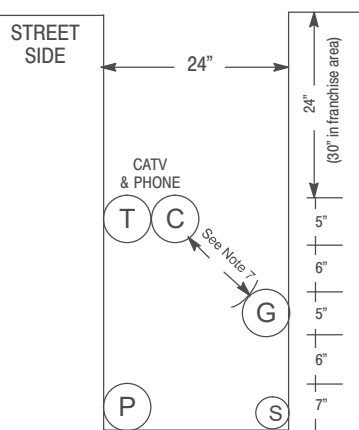


FIG. 4  
24" Wide Joint Trench

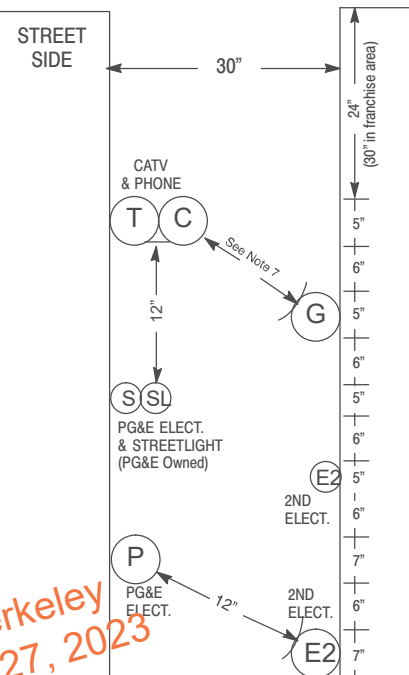


FIG. 5  
Joint Trench With Second  
Electric Utility

cited in Cal. Rest. Ass'n v. City of Berkeley  
No. 21-16278am archived December 27, 2023

### Trench Configuration Notes

The trench configurations shown in this guide are to be considered "typical" only and that other trench widths, depths, as well as utility configurations (placement) may be used, provided all minimum requirements for separation, clearances, and cover are observed. In no case shall electric primary or secondary (excluding street lighting) be placed at a level higher than that of the gas and communications level. Gas shall be placed at the same level or below communications when gas is placed above the electric facilities.

### Special Notes for Joint Trench With Second Electric Utility

- A. Refer to Sheet 3 for General Notes.
- B. A red 3-inch wide "PG&E Electric Line in Conduit" plastic marking tape, Code 375054, shall be installed, spiral wound in a manner that allows for the tape to be readily visible every 3 feet, with each conduit intended to be used for PG&E electric facilities. An equivalent red tape marked to identify the owner shall be installed with the conduit intended to be used for the second electric facility.
- C. Each utility shall ensure adequate grounding between electric facilities is provided (See [UO Standard S5453](#), "Joint Trench").
- D. Provide a minimum of 2 inches of compacted PG&E approved bedding material as a trench leveling concourse, where required. See General Notes Items 11 and 12 (on Page 3), in order to obtain proper compaction.

## JOINT TRENCH CONFIGURATIONS & OCCUPANCY GUIDE

09-27-06

## General Notes

1. The preferred trench location is in a Public Utility easement (P.U.E.).
2. All depths and resulting cover requirements are measured from final grade.
3. Cover, clearances, and separation shall be as great as practicable under the circumstances, but under no circumstances shall be less than the minimum cover, clearance, and separation requirements set forth in [General Order 128](#) and [49CFR 192.321](#), [49CFR 192.325](#), and [49CFR 192.327](#). All facilities shall be anchored in place prior to compaction, or other means shall be taken to ensure no motion of the facilities. Dimensional requirements for shading, leveling, and backfilling shall be determined subsequent to compaction.
4. Trench dimensions shown are typical. Trench sizes and configurations may vary depending upon occupancy and/or field conditions. Trench size and configuration must at all times be constructed in a manner that ensures proper clearances and cover requirements are met. Any "change" to the trench width and configurations as shown in this exhibit must be designed to ensure this requirement.
5. It is preferred to have non-PG&E owned streetlights at a level other than the gas or electric level. Non-PG&E owned streetlights may be at the electric level of the trench as long as minimum clearances are provided and comply with all special notes for a joint trench with a second electric utility.
6. Non-Utility facilities are not allowed in any Joint Utility trench, e.g., irrigation control lines, building fire alarm systems, private telephone systems, outdoor electrical cable, etc.
7. When communication ducts are installed, a minimum of 12" radial separation shall be maintained from gas facilities. Exception: With mutual agreement, when 4-inch diameter or smaller gas pipe is installed, the separation may be reduced to not less than 6 inches.
8. Provide separation from trench wall and other facilities sufficient to ensure proper compaction.
9. Maintain proper separation between PG&E facilities and "wet" utility lines as described in [UO Standard S5453](#). The minimum allowable horizontal separation between Company facilities and "wet" facilities is 3' with a minimum 1' of undisturbed earth or the installation of a suitable barrier between the facilities.

If a 3' horizontal separation cannot be attained between "wet" utilities and Company dry facilities, a variance may be approved by the local Inspection Supervisor and submitted to the Service Planning Support Program Manager for approval. Separations of 1' or less are not permissible and will not be allowed. The Company may agree to waive the minimum 3' separation requirement at the request of an applicant if warranted and the need is justified. The request for a waiver must:

- Be made in writing and submitted to the Company ADE during the planning and design phase of the project,
- Clearly describe the conditions necessitating the waiver.
- Include a proposed design.
- And, include a design for a barrier between the "wet" utilities and Company dry facilities in the event 1' of undisturbed earth cannot be maintained.

Note: Drain lines connected to downspouts on buildings are considered a "wet" utility for the purposes of this standard.

10. Separations shall be maintained at aboveground termination points.
11. Procedures for approving native backfill for shading of PG&E gas facilities:
  - Random soil samples shall be taken from a minimum of 3 locations per 1,000' of trench. 100% of the sample must pass through a 1/2" sieve and 75% must pass through a #4 screen. Additional samples must be taken if existing soil conditions change and are to be taken at the discretion of the PG&E representative on site.
  - The soils must not contain any rocks that have sharp edges or that may otherwise be abrasive.
  - The soils must not contain clods larger than 1/2" if to be used as shading, bedding, or leveling materials.
  - Compaction requirements must meet any applicable PG&E, Federal, State, County, or local requirements.
  - At no time shall the over saturation of native soils be used to achieve these requirements.

The sieves and screens shall be:

- 1/2" Sieve: 8" diameter by 2" deep, stainless steel mesh screen.
- #4 Screen: 8" diameter by 2" deep, stainless steel mesh screen.

*Notes continued on the next page*

## JOINT TRENCH CONFIGURATIONS & OCCUPANCY GUIDE

09-27-06

### General Notes, continued

12. Procedures for approving native backfill for shading at PG&E electric facilities:
- Random soil samples shall be taken from a minimum of 3 locations per 1,000' of trench. Additional samples must be taken if existing soil conditions change and are to be taken at the discretion of the PG&E representative on site.
  - Shading material containing large rock, paving material, cinders, sharply angular substances, or corrosive material shall not be placed in the trench where such material may damage the conduits and/or prevent proper compaction over or around the conduits.
  - Native soils containing clods not to exceed 6" in diameter may be included in the shading material provided the clods are readily breakable by hand.  
**Note:** Soils consisting primarily of adobe, hard compact (dense) clay, and bay muds shall not be used as shading material.
  - At no time shall the over saturation of native soils be used to achieve these requirements.
  - Refer to [Engineering Document 062288](#), Item 13 on Page 2.
13. Competent native soils are preferred to be used for shading, bedding, and backfilling throughout the trench.
- Where native soils exceed 1/2" minus and/or where gas is to be placed at the bottom of a trench in areas that exceed 1/2" minus soil conditions, or where the bottom of a trench is considered to consist of hard pan, PG&E approved 1/2" minus import material shall be used for shading and/or bedding of gas facilities.
  - PG&E approved import material is per [CGT Engineering Guideline 4123](#).
  - If a leveling course is required for gas facilities, the use of native soils is preferred, but if 1/2" minus conditions are not attainable with the native soils, then the use of PG&E approved import materials is required. Bedding under gas facilities will be a minimum of 2" of compacted 1/2" minus native soils or PG&E approved import material.
  - For electric facilities, refer to Note 12. This applies to leveling courses as well as shading.
  - The minimum PG&E approved bedding material may be increased at the discretion of PG&E when warranted by existing field conditions (e.g., rocky soils, hard pan, etc.).
  - The use of any imported material for backfilling purposes shall be limited to those situations when native soils do not allow for required compaction.
14. The applicant is responsible for the removal of excess spoil and associated costs.
15. Separation between gas facilities and electric facilities may be reduced to 6" when crossing.
16. Service saddles are the preferred service fittings for use throughout the joint trench project. All projects will be designed and estimated using service saddles. However, service tees may be used if all clearances, separation, and coverage requirements are maintained.

#### Revision Notes

1. Revised Note 9 to clarify the minimum allowable horizontal separations requirements.
2. This document was revised on 09-27-2006.

## JOINT TRENCH CONFIGURATIONS & OCCUPANCY GUIDE

09-27-06



## New Trench, Backfill, and Warning Tape Requirements for Electric Distribution Only Trenches

### SUMMARY

This utility bulletin communicates new trench, backfill, and warning tape requirements for electric distribution-only trenches. These changes increase the efficiency when installing undergrounding facilities using different equipment and techniques.

Level of Use: Informational Use

### AFFECTED DOCUMENTS

[Numbered Document 038193, "Minimum Requirements for the Design and Installation of Electric Conduit, Insulated Cable and Facilities"](#)

[S5453, Exhibit B, "Joint Trench Configurations and Occupancy Guide"](#)

### TARGET AUDIENCE

Electric operations employees and contractors who design, work on, install, or inspect electric distribution-only trench installations.

### WHAT YOU NEED TO KNOW

#### 1 Background Information

- 1.1 Figures 1 and 2 below show the current PG&E electric distribution-only trench requirements.

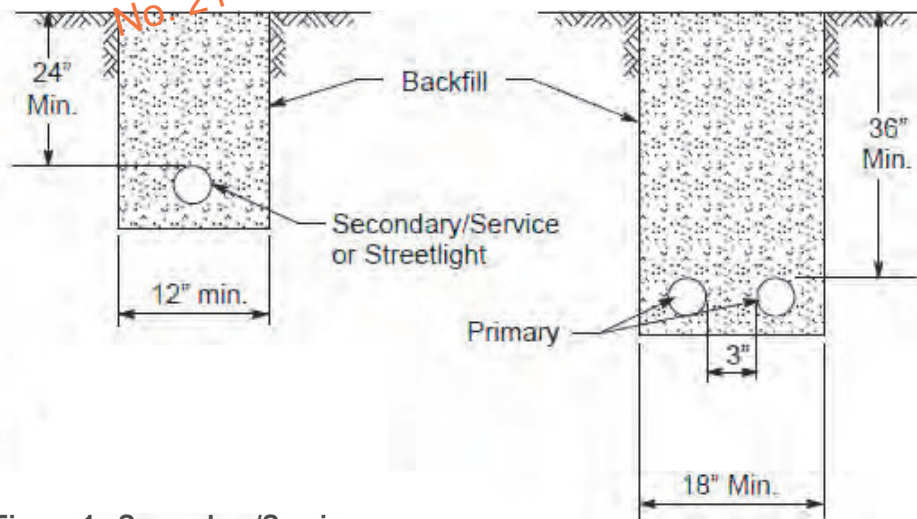


Figure 1. Secondary/Service or Streetlight Trench

Figure 2. Primary Trench

- 1.2 This bulletin communicates a revision to the requirements listed above and introduces the installation of a 6-inch-wide warning tape to be placed 12–18 inches over the center of electric conduits.



## New Trench, Backfill, and Warning Tape Requirements for Electric Distribution Only Trenches

### 2 Required Action

2.1 Figures 3 and 4 below illustrate the new PG&E electric distribution-only trench backfill and warning tape requirements.

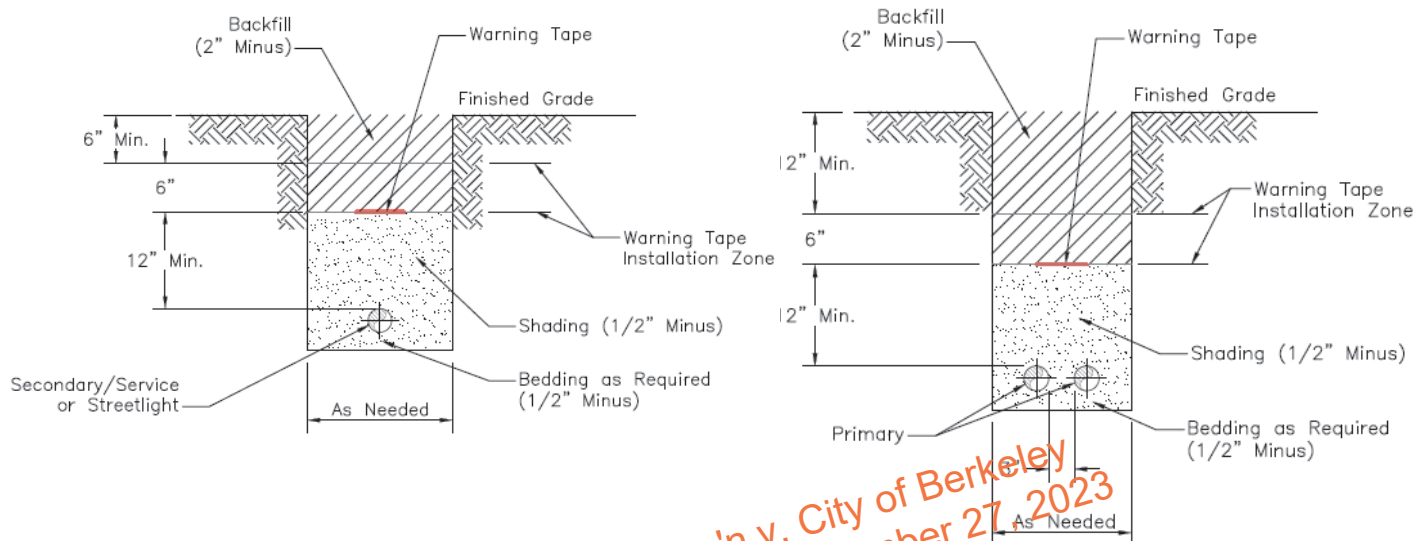


Figure 3. Secondary/Service or Streetlight Trench: Minimum Covered Depth from Top of Conduit is 24 inches

Figure 4. Primary Trench: Minimum Conduit Covered Depth from Top of Conduit is 30 Inches

2.2 The requirement illustrated in Figures 3 and 4 above and described in Sections 2.3 and 2.4 below superceeds General Note 12 in [S5453, Exhibit B, "Joint Trench Configurations and Occupancy Guide."](#)

2.3 Imported sand used for bedding and shading electric-only trenches must meet requirements in [Engineering Material Specification EMS-4123, "Backfill Sand."](#) The only exception to requirements in [EMS-4123](#) is the grain size distribution.

1. Imported sand can contain up to 20% of particles that do not pass through the #200 size sieves.
  - This change allows for better sand compaction and reduces seepage in the trench.
  - This newly approved sand composition requires only screening, with minimum or no wash.
2. Only ADD imported sand for bedding and shading electric-only trenches if native backfill contains any of the following:
  - Large rock



## New Trench, Backfill, and Warning Tape Requirements for Electric Distribution Only Trenches

### 2.3 (continued)

- Paving material
- Cinders
- Large amounts of sharply angular substance
- Corrosive material that may damage conduits, prevent adequate compaction of the fill, or contribute to corrosion of the conduits.
- Native soils exceeding ½ inch minus soil conditions.
- Bottom of a trench consists of rock or hard pan.

- 2.4 INSTALL 6-inch-wide warning tape as shown in [Figure 3](#) and [Figure 4](#) on Page 2. [Figure 5](#) below shows a sample of the approved warning tape.



Figure 5. 6-Inch Warning Electrical Tape

1. USE 6-inch-wide warning tape for all electric-only distribution underground jobs that involve trenching or plow methods.
2. INSTALL tape along the length of the trench AND above the electric conduits, as shown in [Figure 3](#) and [Figure 4](#) on Page 2.
3. Warning tape must be brightly colored red and marked, "Caution: Buried Electric Line Below."
4. STORE warning tape in a manner that limits ultraviolet (UV) exposure.
5. [Table 2](#) on Page 5 provides ordering information for the electrical warning tapes.

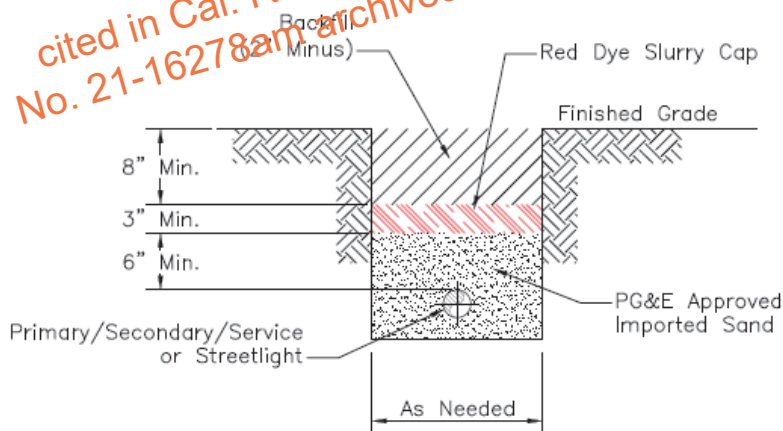
#### NOTE

Above the warning tape, native soils can be up to 2 inches minus soil conditions.



## New Trench, Backfill, and Warning Tape Requirements for Electric Distribution Only Trenches

- 2.5 The minimum depth requirement from finished grade to top of conduits for electric-only trenches only applies when requirements are allowed by federal, state, county, or local ordinances.
- 2.6 IF, **and only IF**, a qualified PG&E associate distribution electric engineer (ADE), construction inspector, AND appropriate external jurisdictions grant their approvals,
- THEN REDUCE the depth by adding adequate mechanical protection as follows (SEE [Figure 6](#)):
1. PLACE a cement-slurry cap over the conduit.
    - The width of the cap must be the same width as the electric-only trench.
    - The top of the cap must be a minimum of 8 inches below grade level.
    - POSITION the cap 6 inches above the conduit, so that the cap rests on rock-free sand and not the conduit.
    - The cap must be a minimum of 3 inches thick and consist of two-sack sand slurry, with red dye mixed in.



**Figure 6. Shallow Trench: Minimum Depth Requirements**

- 2.7 When backfilling trenches on slopes or grades, bags of concrete and red dye may be required on top of the conduit to prevent the backfill from moving down the slope or running out of the trench.
- 2.8 Soil compaction must meet PG&E's and any applicable federal, state, county, and local ordinances.
1. Trenches that run across or along public roads and streets OR in the franchise areas must have soil compacted to a minimum of 95% density.



## New Trench, Backfill, and Warning Tape Requirements for Electric Distribution Only Trenches

2. Trenches that run across private properties AND in all other areas must have soil compacted to a minimum of 90% density.

2.8 (continued)

3. A Compaction Test Report may be required by PG&E. This report must include the testing company information: Name, Address, Contact information.

2.9 The new trench, backfill, and warning tape requirements for electric distribution-only trenches are effective on any PG&E design jobs for New Business and Work Request by Others (NB/WRO) AND on any Applicant Design jobs where Globals are issued **on or after July 05<sup>th</sup>, 2022**.

### 3 Application Criteria

3.1 [Table 1](#) below shows required field actions.

**Table 1. Field Actions**

Activity Type	Action
New Construction	FOLLOW the requirements listed in this utility bulletin when constructing electric only trenches.
Re-Construction Work	
Maintenance	
Emergency	

### 4 Ordering Information

4.1 SELECT the appropriate warning tape from [Table 2](#) below.

**Table 2. Material Codes for Warning Tape**

Description	Unit (feet)	Approved Manufacturers <sup>1</sup>	Material Code
Warning tape, 6-inch wide	1000	ALMETEK TAPE-CBEL	<b>M621910</b>
		PRESCO-D6105R6-457	

<sup>1</sup> ALMETEK is the preferred manufacturer. Presco is an alternative approved manufacturer.

### DOCUMENT APPROVER

Matthew Perez, Supervisor, Electric Distribution Engineering Standards

### DOCUMENT CONTACT

Liseth Villareal, Senior Consulting Electric Standards Engineer

Randy Royval, Principal Electric Distribution Standards Specialist



## New Trench, Backfill, and Warning Tape Requirements for Electric Distribution Only Trenches

Al Valenzuela, Principal Electric Distribution Standards Specialist

### INCLUSION PLAN

The information contained in this bulletin will be included in the next revision of [Numbered Document 038193, "Minimum Requirements for the Design and Installation of Electric Conduit, Insulated Cable, and Facilities."](#)

*cited in Cal. Rest. Ass'n v. City of Berkeley  
No. 21-16278am archived December 27, 2023*



## Updated Separation Requirements For Conduit in Joint Trench

### SUMMARY

This utility bulletin updates [Electric Standard 062288, "Underground Conduits"](#) and [Utility Standard S5453, "Joint Trench"](#) with the requirements listed below:

The minimum separation requirement must be 1.5 inch (in.) between:

- Secondary to: Secondary, service, and streetlight conduit
- Service to: Service and streetlight conduit

The minimum separation requirement must be 3 in. between:

- Primary-to-primary conduit
- Primary to: Secondary, service, and streetlight conduit

This increase in separation is required to improve access to the conduits during future maintenance, re-routing and replacement of the facilities.

Note that the 3 in. requirement above is already included in [Electric Standard 062288](#) but **not** in [Utility Standard S5453](#).

Additionally, separation requirements between Pacific Gas and Electric Company (PG&E or Company) Joint Trench utilities and Non-PG&E owned Foreign Electric duct (e.g., non-PG&E Streetlight) have been added to the updated Table, "Minimum Separation and Clearance Requirements (Inches)", in this utility bulletin. These are not new requirements, but they were not previously located in the Exhibit B table.

The requirements of this bulletin apply to any PG&E job estimate and any PG&E design jobs for New Business and Work Request by Others (NB/WRO), and on any Applicant Design jobs where Globals are issued after the effective date of this bulletin (7/31/2015).

### AFFECTED DOCUMENT

[Utility Standard S5453, "Joint Trench"](#)

[Utility Standard S5453, Exhibit B, "Joint Trench Configurations and Occupancy Guide"](#)

[Electric Standard 062288, "Underground Conduits"](#)

### TARGET AUDIENCE

Personnel in: electric construction, electric distribution engineering, electric estimating, gas distribution estimating, gas distribution engineering, customer service delivery estimating, and gas construction management.



# Updated Separation Requirements For Conduit in Joint Trench

## WHAT YOU NEED TO KNOW

[Utility Standard S5453, "Joint Trench," Exhibit B](#), currently shows:

		G	DUCT T	DB T	C	S	P
G	(GAS) SEE NOTES 4, 7 & 13	—	12"	12"	12"	6"	12"
T	(TELEPHONE) DUCT	12"	—	1"	1"	12"	12"
T	(TELEPHONE) DIRECT BURY	12"	1"	—	1"	12"	12"
C	(CATV)	12"	1"	1"	—	12"	12"
S	(ELECTRIC SECONDARY)	6"	12"	12"	12"	—	3"
P	(ELECTRIC PRIMARY)	12"	12"	12"	12"	—	—
SL	(STREETLIGHT) SEE NOTE 5	6"	12"	12"	12"	1.5"	3"

[Utility Standard S5453, "Joint Trench," Exhibit B](#), is updated per this bulletin as follows:

		G	DUCT T	DB T	C	S	P	SL
G	(GAS) SEE NOTES 4,7, & 13	-	12	12	12	6	12	6
T	(TELEPHONE) DUCT	12	-	1	1	12	12	12
T	(TELEPHONE) DIRECT BURY	12	1	-	1	12	12	12
C	(CATV)	12	1	1	-	12	12	12
S	(ELECTRIC SECONDARY)	6	12	12	12	1.5	3	1.5
P	(ELECTRIC PRIMARY)	12	12	12	12	3	3	3
SL	(STREETLIGHT) SEE NOTE 5	6	12	12	12	1.5	3	1.5
FE*	(FOREIGN ELECTRIC SOURCES, NON-PG&E*) SEE NOTE 5	12	12**	12**	12**	12	12	12

\*Must be considered a 'Utility' as defined in [Utility Standard S5453, "Joint Trench."](#)

Notes 4, 5, 7, and 13 are located in [Utility Standard S5453, Exhibit B, "Joint Trench Configurations and Occupancy Guide."](#)

\*\*For exceptions, refer to G.O. 128 rule, Section B, Items (1) and (2).



## Updated Separation Requirements For Conduit in Joint Trench

### DOCUMENT APPROVER

Jim Herren, Manager, Gas Distribution Engineering and Design

### DOCUMENT CONTACT

Lisbeth Villareal, Electric Standards Engineer, Sr

David Krause, Gas Engineer, Codes and Standards - Design and Construction

John Pickering, Expert Business Process Analyst, Distribution Engineering and Design Support

Daniel Jantz, Expert Engineering Standards Technical Specialist, EAM Distribution Standards

### INCLUSION PLAN

This update will be included in the next revision of [Electric Standard 0662288 "Underground Conduits"](#) and [Utility Standard S5453, "Joint Trench," Exhibit B](#)

*cited in Cal. Rest. Ass'n v. City of Berkeley  
No. 21-16278am archived December 27, 2023*



cited in Cal. Rest. Ass'n v. City of Berkeley  
No. 21-16278am archived December 27, 2023



# Enhanced Vegetation Management Pre-Inspection Procedure

## SUMMARY

This procedure describes how to perform pre-inspection patrols specific to the Enhanced Vegetation Management (EVM) program in effort to reduce vegetation related risks to electric distribution and transmission facilities.

Level of Use: Informational Use

## TARGET AUDIENCE

Vegetation management (VM) operational employees and contractors involved in pre-inspection (PI) activities.

## SAFETY

NA

## BEFORE YOU START

NA

## TABLE OF CONTENTS

*cited in Cal. Rest. Ass'n v. City of Berkeley  
 No. 21-16278am archived December 27, 2023*

SUBSECTION	TITLE	PAGE
1	General Expectations .....	2
2	Overhanging Vegetation.....	2
3	Primary Conductor Radial Clearance .....	2
4	Trees with Strike Potential.....	3
5	LIDAR Based Vegetation Points.....	3
6	Customer Refusal .....	4
	Appendix A, Diagram of EVM Tree Work Standards.....	6



## Enhanced Vegetation Management Pre-Inspection Procedure

### PROCEDURE STEPS

#### 1 General Expectations

1.1 All overhead electric distribution and transmission facilities must be inspected for the following conditions:

- Vegetation overhanging the conductors, per [Section 2](#).
- Vegetation currently or potential to encroach within 4-ft. of the primary conductor before the next routine cycle, per [Section 3](#).
- Vegetation tall enough to strike the facilities, per [Section 4](#).

1.2 IF there is any known risk to the electric facilities, THEN prescribe the tree for work.

1.3 IF the prescribed tree work will create a subsequent hazard, THEN prescribe tree for removal.

1.4 IF the tree is observed within the minimum distance requirements (MDR) (see [Utility Procedure TD-7102P-01](#), "Vegetation Management Distribution Route Patrol Procedure") or the tree is failing,

THEN follow [Utility Procedure TD-7103P-09](#), "Vegetation Management Hazard Notification Procedure."

1.5 WHEN an abnormal field condition is identified, THEN follow [Utility Procedure TD-7102P-09](#), "Reporting Abnormal Field Conditions Procedure."

#### 2 Overhanging Vegetation

2.1 The PI must prescribe clearance of any vegetation if:

- The vegetation is currently within the 4-ft. vertical plane (see [Appendix A](#)) of primary conductor, or
- The vegetation will enter the 4-ft. vertical plane before the next routine/compliance cycle.

#### 3 Primary Conductor Radial Clearance

3.1 For vegetation with the potential to encroach within a 4-ft. radius of the primary conductor before the next routine/compliance tree work cycle, PRESCRIBE a minimum of 12-ft. radial clearance.



## Enhanced Vegetation Management Pre-Inspection Procedure

3.2 Coastal redwoods and giant sequoias are not required to be removed or mitigated below conductor height (i.e. "topped") when the tree trunk occurs within the 4-ft. radius of the primary conductor, IF the tree has no indications of any of the following conditions:

- Re-sprouting from the bole of the tree resulting in annual non-compliance.
- Significant defects.
- Poor trunk attachments related to secondary re-growth from past trunk failures.

### 4 Trees with Strike Potential

4.1 INSPECT all trees tall enough to strike facilities.

4.2 IF the tree is tall enough to strike, CREATE a vegetation point. For LIDAR generated vegetation points, refer to [Section 5](#).

4.3 ASSESS the tree using the tree assessment tool (TAT) within GISArc Collector.

- For trees with an "abate" result, PRESCRIBE the tree work to remove the risk.
- For trees with a "do not abate" result, POPULATE fields as follows:
  - Status select "No Work Required under EVM."
  - Prescription select "NW\_No Work."

### 5 LIDAR Based Vegetation Points

#### NOTE

Vegetation points based on LIDAR data are considered accurate. Physical validation is required before the inspection is considered complete. This will ensure all trees with strike potential are properly identified and mitigated.

5.1 All LIDAR based vegetation points must be validated by a PI.

5.2 The PI must assess each vegetation point, as specified in [Step 1.1](#).

5.3 IF a tree does not exist (e.g. two vegetation points are listed but one tree was physically removed) or is clearly not tall enough to strike facilities at time of inspection, THEN populate the vegetation point fields as follows:

- Status select "Not Valid."
- TAT Result select "Not a Strike Tree."



## Enhanced Vegetation Management Pre-Inspection Procedure

### 6 Customer Refusal

- 6.1 IF the customer refuses removal or pruning, THEN FOLLOW [Utility Procedure TD-7102P-04, "Distribution Vegetation Refusal Procedure."](#)

### END of Instructions

### DEFINITIONS

**Facilities:** Any electrical or non-electrical conductors or apparatus on a pole, the pole, or any pole supporting wires. Service drops are excluded.

**LIDAR:** Stands for Light Detection and Ranging. Data collected and generated by remote sensing technology using light detection.

**Trees:** Vegetation with a diameter at breast height (DBH) of 4-in. or more.

**Vegetation point:** A data point used to represent a tree in the VM inventory system.

**Vertical plane:** The area created by horizontally extending 4-ft. from both sides of the outer most conductor then vertically extending to the sky (i.e. football goal post).

### IMPLEMENTATION RESPONSIBILITIES

The vegetation management document owner is responsible for the rollout, communication, and periodic review of this utility procedure. Vegetation management operations personnel are responsible for taking the applicable training and executing the procedure where applicable.

### GOVERNING DOCUMENT

[Utility Standard TD-7102S, "Distribution Vegetation Management Standard \(DVMS\)"](#)

### COMPLIANCE REQUIREMENT / REGULATORY COMMITMENT

[General Order \(G.O.\) 95, Rule 35](#)

[Public Resources Code \(PRC\), Section 4293](#)

### REFERENCE DOCUMENTS

#### Developmental References:

Cal Fire Power Line Fire Prevention Field Guide, 2008 revision



# Enhanced Vegetation Management Pre-Inspection Procedure

### Supplemental References:

[Utility Procedure TD-7102P-01, "Vegetation Management Distribution Routine Patrol Procedure"](#)

[Utility Procedure TD-7103P-09, "Vegetation Management Hazard Notification Procedure"](#)

### APPENDICES

NA

### ATTACHMENTS

NA

### DOCUMENT REVISION

NA

### DOCUMENT APPROVER

Derek Cedars, Director of Program Management, Vegetation Management

#### Concurrence:

Joey Perez, Manager, Vegetation Management

*cited in Cal. Rest. Ass'n v. City of Berkeley  
No. 21-16278am archived December 27, 2023*

### DOCUMENT OWNER

Joey Perez, Manager, Vegetation Management

### DOCUMENT CONTACT

Ryan Willis, Manager, Vegetation Management

### REVISION NOTES

Where?	What Changed?
NA	NA



# Enhanced Vegetation Management Pre-Inspection Procedure

## Appendix A, Diagram of EVM Tree Work Standards

Page 1 of 1

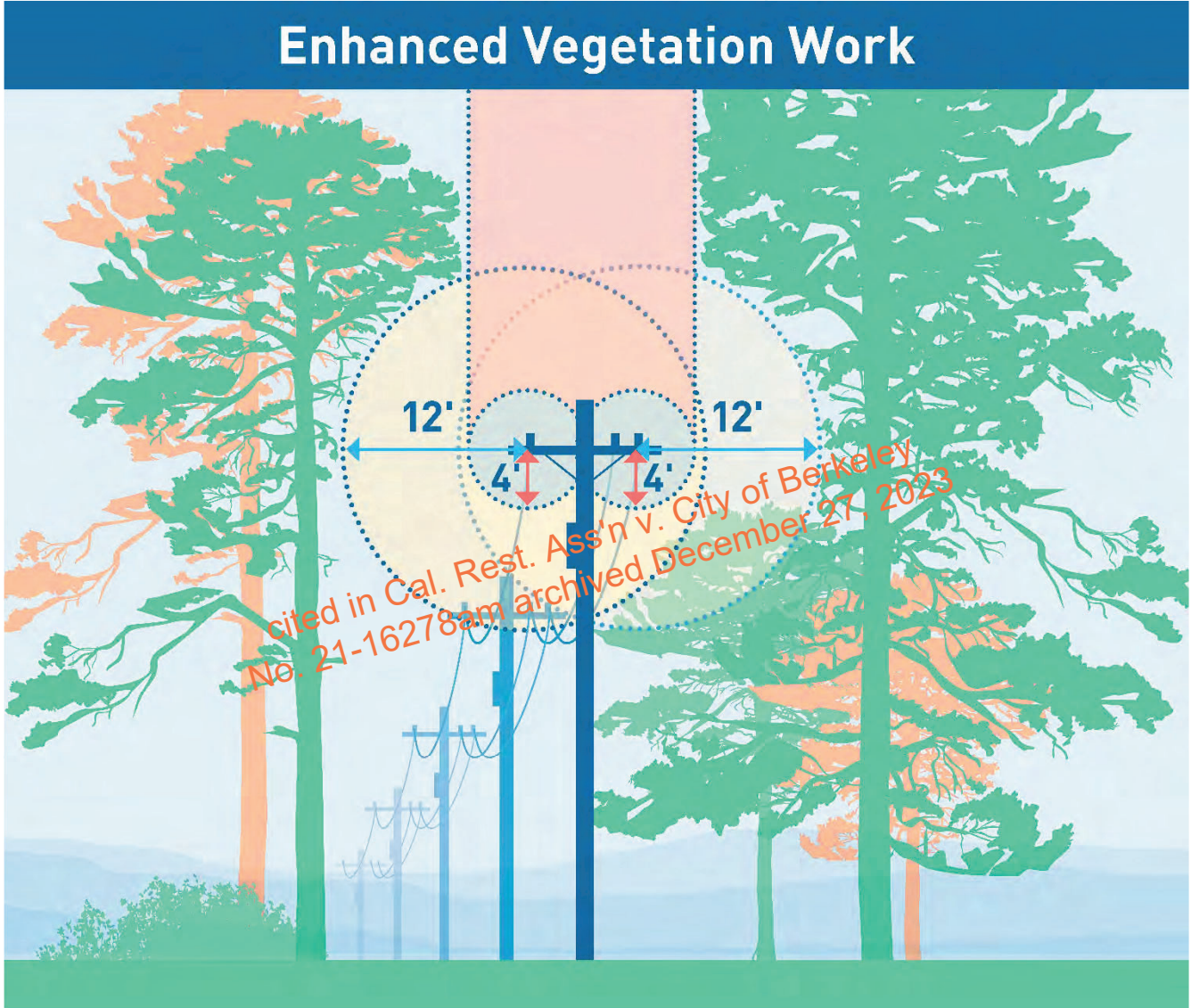


Figure 1. Diagram of EVM Tree Work Standards

**APPENDIX C  
ELECTRIC AND GAS  
ENGINEERING DOCUMENTS**

*cited in Cal. Rest. Ass'n v. City of Berkeley  
No. 21-16278am archived December 27, 2023*



**APPENDIX C ELECTRIC AND GAS ENGINEERING DOCUMENTS**

*cited in Cal. Rest. Ass'n v. City of Berkeley  
No. 21-16278am archived December 27, 2023*

## Appendix C

### Electric and Gas Engineering Documents

Appendix C contains the electric numbered engineering documents and gas design standards listed in Table C-1 and Table C-2, below. Pacific Gas and Electric Company (PG&E) may revise its design and construction documents relating to applicant service requirements between updates to the bound hardcopy manual. The bound manual is not reprinted until the next scheduled print date regardless of changes in processes or requirements. **Therefore, it is imperative that applicants access PG&E’s Internet website at [www.pge.com/greenbook](http://www.pge.com/greenbook) to find the latest versions of, and updates to, these documents.** Also, applicants may contact their local PG&E service planning office to ensure their documents are current.

**NOTE:** See Table FM-1, “Service Planning Office and Inspection Desk Contact Information,” at the front of this manual starting on [Page iv](#), for specific contact numbers listed by area.

**Table C-1 Gas Design Standards**

Section <sup>1</sup>	Document Number	Title
A: Pipes, Mains, and Services <sup>1</sup>	<a href="#">A-03</a>	<a href="#">Gas Trench Design and Construction</a>
	<a href="#">A-04</a>	<a href="#">Cover and Clearance Requirements for Transmission Lines, Distribution Mains, and Service Lines</a>
	<a href="#">A-42</a>	<a href="#">Standard Branch Service Installation</a>
	<a href="#">A-43.2</a>	<a href="#">Curb Valves</a>
	<a href="#">A-75</a>	<a href="#">Gas Service and Mains in Plastic Casing</a>
	<a href="#">A-81</a>	<a href="#">Plugs and Caps for Non-Pressurized Gas Pipelines</a>
	<a href="#">A-90</a>	<a href="#">Polyethylene Gas Distribution System Design</a>
	<a href="#">A-93.1</a>	<a href="#">Installing and Maintaining a Polyethylene (PE) Gas Distribution System</a>
	<a href="#">A-93.3</a>	<a href="#">Excess Flow Valves</a>
J: Meters, Gauges and Instruments <sup>1</sup>	<a href="#">J-12.4</a>	<a href="#">Mobile Home/Manufactured Home Meter Set Installation</a>
	<a href="#">J-15</a>	<a href="#">Gas Meter Locations</a>
	<a href="#">J-16</a>	<a href="#">Gas Meter Room</a>
	<a href="#">J-65.1</a>	<a href="#">Volume Pulse Output Connection for Gas Meters</a>
	<a href="#">J-95</a>	<a href="#">Meter Guard Design and Installation Arrangement</a>
K: Pits, Vaults, Boxes, and Shelters <sup>1</sup>	<a href="#">K-51</a>	<a href="#">Single Meter Cabinet for Domestic Gas Meters</a>
L: Marker Tags, Signs, Barricades, and Fences	<a href="#">L-16</a>	<a href="#">Gas Pipeline Underground Warning Tape</a>
<i>Greenbook</i> <sup>2</sup>	<a href="#">N-01</a>	<a href="#">PG&amp;E Approved Gas Materials Manufacturers</a>

<sup>1</sup> For PG&E reference only: “Section” refers to the section in PG&E [TD-4950M, Gas Design Standards Manual](#), which contain these documents.

<sup>2</sup> This document is not in [TD-4950M, Gas Design Standards Manual](#).

**Table C-2 Electric Engineering Documents**

Section <sup>1</sup>	Document Number	Title
Underground <sup>1</sup> "Connectors"	<a href="#">013109</a>	<a href="#">Corrosion Resistant Ground Rods and Ground Rod Clamps</a>
Underground <sup>1</sup> "Connectors"	<a href="#">015251</a>	<a href="#">Connectors for Insulated Cables Underground Distribution Systems</a>
Overhead <sup>1</sup> "Services"	<a href="#">025055</a>	<a href="#">Requirements for Customer-Owned Poles</a>
Overhead <sup>1 3</sup> "Services"	<a href="#">027911</a>	<a href="#">Installation Details for Service to Pole-Mounted Communication Equipment</a>
Underground <sup>1</sup> "Enclosures"	<a href="#">028028</a>	<a href="#">Secondary Electric Underground Enclosures</a>
Underground <sup>1</sup> "Services"	<a href="#">036670</a>	<a href="#">Temporary Underground Electric Service Single-Phase, 120/240 Volt, 200 Amps Maximum</a>
Underground <sup>1</sup> "Cable"	<a href="#">038193</a>	<a href="#">Minimum Requirements for the Design and Installation of Electric Conduit, Insulated Cable, and Facilities</a>
Underground <sup>1</sup> "Transformers"	<a href="#">041352</a>	<a href="#">Service Entrance From Underground Vault Using Bus Bars</a>
Underground <sup>1</sup> "Transformers"	<a href="#">045292</a>	<a href="#">Concrete Pad for Three-Phase, Loop-Style, Pad-Mounted Transformers</a>
Underground <sup>1</sup> "General"	<a href="#">051122</a>	<a href="#">Clearances and Location Requirements for Enclosures, Pads, and Underground Equipment</a>
<i>Greenbook</i> <sup>2</sup>	<a href="#">052521</a>	<a href="#">Electrical Service Requirements for Mobile Home Developments</a>
Underground <sup>1</sup> "Services"	<a href="#">054619</a>	<a href="#">Agricultural Underground Service 500 HP or Less</a>
Underground <sup>1</sup> "Services"	<a href="#">054712</a>	<a href="#">Permanent Wood Post Installation Underground Electric Service</a>
Engineering Standards <sup>2</sup>	<a href="#">055103</a>	<a href="#">Planning Guide for Single Customer Substations Served From Transmission Lines</a>
Underground <sup>1</sup> "Transformers"	<a href="#">057521</a>	<a href="#">Pad-Mounted Transformer Installed Indoors</a>
Overhead <sup>1</sup> "Services"	<a href="#">058087</a>	<a href="#">Agricultural Overhead Service 300 HP or Less</a>
<i>Greenbook</i> <sup>2</sup>	<a href="#">060559</a>	<a href="#">Disconnect Switch Requirements For Distributed Generation Customers</a>
Underground <sup>1</sup> "Services"	<a href="#">061032</a>	<a href="#">Residential and Small Commercial Overhead to Underground Electric Service Conversion</a>
Underground <sup>1</sup> "Services"	<a href="#">062000</a>	<a href="#">Primary Electric Underground Enclosures</a>

<sup>1</sup> For PG&E reference only: "Section" refers to the section in PG&E's [Electric Overhead Construction Manual](#) or [Electric Underground Construction Manual](#), Volumes 1 and 2, which contain these documents.

<sup>2</sup> This document is not in the [Electric Overhead Construction Manual](#) or [Electric Underground Construction Manual](#).

<sup>3</sup> This document is not in the printed manual and is available only in the online version of the [Greenbook](#) on [www.pge.com/greenbook](http://www.pge.com/greenbook).

**Table C-2 Electric Engineering Documents, continued**

Section 1	Document Number	Title
Underground <sup>1</sup> "Transformers"	<a href="#">062111</a>	<a href="#">Application of Underground Distribution Transformers</a>
Underground <sup>1</sup> "Conduits"	<a href="#">062288</a>	<a href="#">Underground Conduits</a>
<i>Greenbook</i> <sup>2</sup>	<a href="#">063422</a>	<a href="#">Landscape Screen for Pad-Mounted Transformers</a>
Underground <sup>1</sup> "Services"	<a href="#">063927</a>	<a href="#">Methods and Requirements for Installing Residential Underground Electric Services 0–600 V to Customer-Owned Facilities</a>
Underground <sup>1</sup> "Services"	<a href="#">063928</a>	<a href="#">Methods and Requirements for Installing Non-Residential Underground Electric Services 0–600 Volts to Customer-Owned Facilities</a>
Underground <sup>1</sup> "Services"	<a href="#">063929</a>	<a href="#">Requirements for Bus Duct Entrance Termination Unit for Use With Pad-Mounted Transformers</a>
Underground <sup>1</sup> "Transformers"	<a href="#">064309</a>	<a href="#">Box-Pad for Pad-Mounted Transformers</a>
Overhead <sup>1</sup> "Services"	<a href="#">065374</a>	<a href="#">Overhead and Underground Panel Board Construction</a>
<i>Greenbook</i> <sup>2</sup>	<a href="#">066211</a>	<a href="#">PG&amp;E-Approved Electric Distribution Materials Manufacturers</a>
<i>Greenbook</i> <sup>2</sup>	<a href="#">068179</a>	<a href="#">Service to Cellular on Transmission Tower</a>
Underground <sup>1</sup> "General"	<a href="#">072149</a>	<a href="#">Requirements for Allowing Installation of Subsurface Transformers</a>
<i>Greenbook</i> <sup>2</sup>	<a href="#">076249</a>	<a href="#">Virtual Net Energy Metering Installations</a>
Underground <sup>1</sup> "General"	<a href="#">076268</a>	<a href="#">Painting of PG&amp;E Electric Distribution Pad-Mounted and Subsurface Equipment</a>
Underground <sup>1</sup> and Overhead <sup>1</sup> "Services" <i>Greenbook</i>	<a href="#">092816</a>	<a href="#">Wholesale Distribution Tariff (WDT) Interconnection Design Options for Primary Voltage Service</a>
<i>Greenbook</i> <sup>2</sup>	<a href="#">094670</a>	<a href="#">Supply Side Interconnection Requirements for Distributed Generation</a>
Underground <sup>1</sup> "Services" and Overhead <sup>1</sup> "Meters" <i>Greenbook</i>	<a href="#">094675</a>	<a href="#">SmartPole Meter for Service to Pole-Mounted Communication Equipment<sup>3</sup></a>
Underground <sup>1</sup> and Overhead <sup>1</sup> "Services" <i>Greenbook</i>	<a href="#">094676</a>	<a href="#">Primary Electric Service Requirements</a>
Underground <sup>1</sup> "Services" <i>Greenbook</i>	<a href="#">094677</a>	<a href="#">PG&amp;E Metered Electric Service to Antenna and Communication Equipment on Company Owned Steel Streetlight Poles<sup>3</sup></a>
Underground <sup>1</sup> and Overhead <sup>1</sup> "Services" <i>Greenbook</i>	<a href="#">094678</a>	<a href="#">PG&amp;E Electric Service to Antenna and Communication Equipment on Municipality Owned Steel Streetlight Poles<sup>3</sup></a>

<sup>1</sup> For PG&E reference only: "Section" refers to the section in PG&E's [Electric Overhead Construction Manual](#) or [Electric Underground Construction Manual](#), Volumes 1 and 2, which contain these documents.

<sup>2</sup> This document is not in the [Electric Overhead Construction Manual](#) or [Electric Underground Construction Manual](#).

<sup>3</sup> This document is not in the printed manual and is available only in the online version of the [Greenbook](#) on [www.pge.com/greenbook](http://www.pge.com/greenbook).

Section <sup>1</sup>	Document Number	Title
Underground <sup>1</sup> and Overhead <sup>1</sup> "Services" <i>Greenbook</i>	<a href="#">094679</a>	<a href="#">PG&amp;E Metered Electrical Service to Antenna and Communication Equipment on Non-PG&amp;E Telecommunication Owned Poles</a> <sup>3</sup>
<i>Greenbook</i> <sup>2</sup>	<a href="#">094683</a>	<a href="#">SmartMeter Electric Network Requirements for Indoor Meter Rooms and High-Rise Buildings</a>
<i>Greenbook</i> <sup>2</sup>	<a href="#">094684</a>	<a href="#">Green Meter Adapter (GMA) for Customer Generation</a> <sup>3</sup>

<sup>1</sup> For PG&E reference only: "Section" refers to the section in PG&E's [Electric Overhead Construction Manual](#) or [Electric Underground Construction Manual](#), Volumes 1 and 2, which contain these documents.

<sup>2</sup> This document is not in the [Electric Overhead Construction Manual](#) or [Electric Underground Construction Manual](#).

<sup>3</sup> This document is not in the printed manual and is available only in the online version of the [Greenbook](#) on [www.pge.com/greenbook](http://www.pge.com/greenbook).

cited in Cal. Rest. Ass'n v. City of Berkeley  
No. 21-16278am archived December 27, 2023



## GAS DESIGN STANDARD GAS TRENCH DESIGN AND CONSTRUCTION

A-03

Publication Date: 08/19/2020 Effective Date: 11/16/2020 Rev. 0a

### Purpose and Scope

This gas design standard (GDS) provides general trench requirements for Pacific Gas and Electric Company (PG&E or Company) gas transmission and distribution facilities. It includes dimensions, acceptable materials to place in the trench, and damage prevention requirements. This GDS does not apply to pipe installed with trenchless construction methods.

### 1 General Information

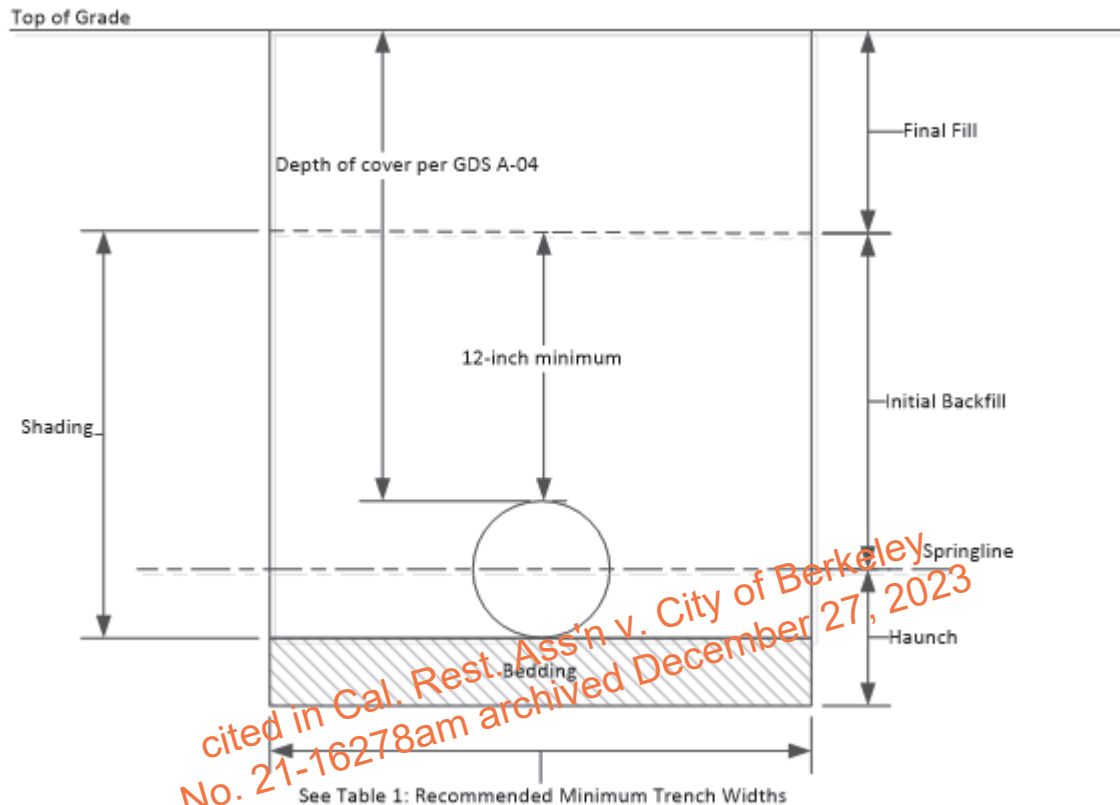
- 1.1. PG&E has an obligation to repair and pave public streets and roads to the same conditions as found. PG&E trenches must meet the requirements of the local permitting agency unless the requirements are determined to be arbitrary, unreasonable, or pose a potential risk to the integrity of the facilities or safety of the public and PG&E crews during construction and routine maintenance.
- 1.2. Due to the large number of local permitting agencies within the PG&E service territory, it is outside of the scope of this GDS to address all possible local agency trench and backfill requirements. When this GDS differs from local agency requirements it is the responsibility of the local leadership, design and asset engineering and corrosion services teams to evaluate the agency requirements and/or coordinate with the local agency to develop a local trench design that is acceptable to both PG&E and the local agency.
- 1.3. This GDS provides the recommended minimum requirements for trench configuration and backfill requirements. The project team, responsible asset engineer and corrosion services should evaluate each location and determine if a site specific trench design is required and has final authority to approve any deviation from the Issued for Construction (IFC) drawings.
- 1.4. For joint trench requirements refer to Utility Standard S5453, "Joint Trench."
- 1.5. For required cover and clearances refer to Gas Design Standard A-04, "Cover and Clearance Requirements for Transmission Lines, Distribution Mains, and Service Lines."

**Gas Trench Design and Construction****A-03**

Publication Date: 08/19/2020 Effective Date: 11/16/2020 Rev. 0a

**2 Trench Configuration**

2.1. A typical gas only trench is shown in Figure 1.

**Figure 1. Typical Gas Only Trench Configuration****2.2. Basic Trench Design Construction and Terminology**

- A. **Bedding:** The bottom of the trench must be cleared of rocks, skid blocks, or other hard substances to provide a continuous smooth base for the pipe to rest on without damage to the coating. A padding of fine earth or sand can be provided to cushion the pipe. The thickness of the padding should be  $\frac{1}{3}$  the outside diameter of the pipe, but not less than 4 inches.
- B. **Haunch:** The backfill material under the pipe haunches supports the pipe and helps to distribute the load evenly. The quality and placement of the haunching backfill is the most important factor in pipe settlement.
- C. **Shading:** Material that provides support from lateral displacement, distributes overhead loads, and protects the pipe during final backfilling and paving operations.

**Gas Trench Design and Construction****A-03****Publication Date:** 08/19/2020 **Effective Date:** 11/16/2020 **Rev.** 0a

## 2.2 (continued)

- D. Initial Backfill: A backfill of fine materials must be placed to a minimum elevation of 12 inches over the top of the pipe, to prevent damage from rocks while backfilling above this level.
- E. Final Backfill/Paving: In most cases, competent native fill is acceptable and preferred for final backfill. Paving must match any existing paving that was removed in the construction of the pipe.

## 2.3. Trench Width

- A. Trench must be wide enough to allow for the installation of the pipe without damaging coating or inducing unnecessary stresses and to safely and conveniently compact backfill material on either side of the pipe.
- B. At horizontal angles, the trench must have sufficient width to accommodate the welding elbow or bend and provide clearance between the side of the trench and the pipe.
- C. At locations where welding is to occur in the trench, it must be wide enough to also safely accommodate welding personnel.
- D. According to *The Performance Pipe™ Engineering Manual, 2013*, the recommended minimum trench widths are listed in Table 1.

**Table 1. Recommended Minimum Trench Widths**

Nominal Pipe OD (in.)	Minimum Trench Width (in.)
< 3	12
3–16	Pipe OD + 12
18–34	Pipe OD + 18
36–63	Pipe OD + 24

## 2.4. Trench Depth

- A. Personnel performing excavations must follow safety guidelines provided in Utility Procedure TD-4412P-05, "Excavation Procedures for Damage Prevention," and Utility Manual TD-4621M, "Excavation Safety Manual."
- B. The trench must be deep enough to provide the minimum cover as outlined in GDS A-04.

## 2.5. Warning Tape

- A. A 6 inch warning tape must be installed above the pipe per Gas Design Standard L-16, "Gas Pipeline Underground Warning Tape."



**Gas Trench Design and Construction****A-03**

Publication Date: 08/19/2020 Effective Date: 11/16/2020 Rev. 0a

**3 Trench Backfill Material**

## 3.1. General

- A. From a corrosion, logistical, and affordability perspective, competent native soil is preferred for bedding, shading, and backfilling material throughout the trench.
- B. When native material is determined to be unsuitable for bedding and shading, a PG&E approved import of fine material or sand is required for the bedding and shading material.
- C. Import sand used as bedding and shading material must meet the requirements in Engineering Material Specification (EMS)-4123, "Backfill Sand."

## 3.2. Competent Native or Import Material Specifications

## A. General

- (1) Do not use organic soils (including peat, humus, topsoil, swamp soils, mulch, and soils containing leaves), grass, branches, or other fibrous vegetable matter as bedding and shading material.

## B. Distribution

- (1) Bedding and Shading Material

*cited in Cal. Rest. Ass'n v. City of Berkeley  
No. 21-16278 am archived December 27, 2023*

a) Native or import material used for bedding or shading must meet the following criteria: Gradation requirements as determined by American Society for Testing and Materials (ASTM) C136M-14, "Standard Test Method for Sieve Analysis of Fine and Coarse Aggregates," are shown in Table 2.

**Table 2. Bedding and Shading Material Gradation Requirements**

Sieve U.S.	Particle Size (in)	Spec
1/2	0.5	100%
#4	0.187	75%

- b) The material must not contain rocks with sharp edges or that may be abrasive. In general, rocks can be round to sub-round as shown in Figure 2, "Angularity Example."

**Gas Trench Design and Construction****A-03**

Publication Date: 08/19/2020 Effective Date: 11/16/2020 Rev. 0a

## 3.2 (continued)

- (2) Final Backfill Material
  - a) Native or import final backfill material must meet the following criteria:
  - b) The soil must not contain large rocks, clods, or lumps of soil greater than 3 inches.
  - c) The soil must be free of construction debris, sticks, stumps, garbage, or other organic materials.

## C. Transmission

- (1) Bedding and Shading
  - a) The material must not contain rocks with sharp edges or that may be abrasive. In general, round to sub-round rocks are acceptable as shown in Figure 2.
  - b) The material must be screened for rocks and clods of soil greater than 1 inch.
- (2) Final Backfill Material
  - a) Native or import final backfill material must meet the following criteria: The soils must not contain large rocks, clods, or lumps of soil greater than 3 inches.
  - b) The soil must be free of construction debris, sticks, stumps, garbage, or other organic materials.

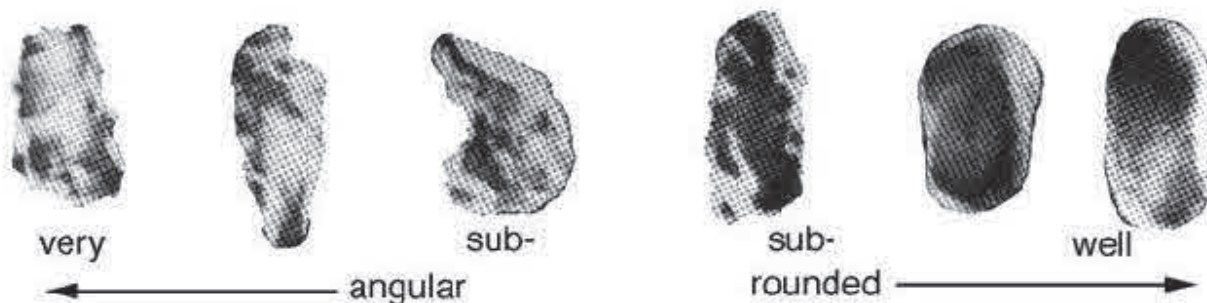


Figure 2. Angularity Example

**Gas Trench Design and Construction****A-03**

Publication Date: 08/19/2020 Effective Date: 11/16/2020 Rev. 0a

**4 Other Design Considerations**

## 4.1. Corrosion Potential

A. Although the coating and cathodic protection are the primary methods of protecting steel pipe from corrosion, it is recommended that the native or import soil be evaluated for corrosion potential before being used as bedding or shading backfill. Tests and recommended limits are listed below:

- (1) pH must be between 4.5 and 9.
- (2) Contact corrosion engineering services personnel for additional information and/or approved tests.

## 4.2. Above Ground Piping

A. Soil with low compaction around above group piping can cause settlement and additional stress to pipe at air to soil transitions.

- (1) Consider providing site-specific compaction requirements of at least 90%, appropriate methods of placement and compaction, and testing requirements and intervals.

## 4.3. Site Specific Design

A. Consider providing a site specific trench design and construction method at locations where there is the potential for the following.

- (1) Areas where ground settlement is a concern.
- (2) Water transmission in trench that could potentially cause trench settlement and failure.
- (3) Locations of known or potential landslides.
- (4) High ground water table.

B. For assistance with the identification of potential issues and site evaluation contact the following.

- (1) Identification of known geologic hazards:
  - a) Transmission Integrity Management Program (TIMP) engineering geohazard personnel.
  - b) Distribution Integrity Management Program (DIMP) engineering personnel.
- (2) Geotechnical support personnel.

**Gas Trench Design and Construction****A-03****Publication Date:** 08/19/2020 **Effective Date:** 11/16/2020 **Rev.** 0a**5 Placement and Compaction**

**Note:** It is extremely important that PG&E meet the minimum performance requirements for compaction required by the local permitting agency. Settlement and trench failures due to poor workmanship in public roads are public safety hazards.

**5.1. General**

- A. Trench backfill compaction must meet local agency permit requirements or IFC drawings, whichever is more conservative.
- B. Outside of public roads and franchise, backfill compaction is not required unless specified by the responsible design or asset engineer in the IFC drawings.
  - (1) It is recommended that backfill be compacted where ground settlement is a concern or potential risk.

**5.2. Placement**

- A. Avoid damaging the pipe and pipe coating when placing the shading material.
- B. Use caution when placing shading material on top of pipe service connections and transition fittings.

**5.3. Compaction**

- A. Bedding
  - (1) The trench bottom needs to provide firm, uniform, and adequate support for the pipe.
    - a) In a trench that contains voids, consider using a concrete vibrator to assist with consolidation when using wet sand for bedding.
- B. Shading
  - (1) No compaction operations that could damage the pipe coating are allowed. Protect the pipe in place during compaction operations.
  - (2) Compaction operations of shading backfill should take place adjacent to the pipe. Do not compact directly over the pipe until there are at least 12 inches of cover over the pipe.

**Gas Trench Design and Construction****A-03****Publication Date:** 08/19/2020 **Effective Date:** 11/16/2020 **Rev.** 0a

## 5.3 (continued)

- C. Final Fill
- (1) Lift heights must be of sufficient depth to attain the required compaction based on the type of material and method of compaction, for example:
    - a) Sandy fill must be placed in lifts no greater than 6 to 9 inches and compacted using a vibrating plate compactor.
    - b) Clayey fill must be placed in 6 to 9 inch lifts and compacted using a rammer (jumping jack).
- D. Consult the responsible design or asset engineer for minimum cover or additional protection requirements for pipe when using large compaction equipment such as a sheep's foot roller or vibrating compaction roller.

## 5.4. Testing

- A. Testing requirements and intervals are required by the permitting agency or as specified in the IFC drawings. In absence of specific guidance, Caltrans provides a conservative approach.
- (1) ASTM D1557, "Laboratory Compaction Characteristics of Soil Using Modified Effort" or equivalent
    - a) One sample every 2000 cubic yards.
  - (2) ASTM D6938-15, "Standard Test Methods for In-Place Density and Water Content of Soil and Soil-Aggregate by Nuclear Methods (Shallow Depth)"
    - a) One test every 8 inches of thickness.

**6 Slurry and Controlled Low Strength Material (CLSM) Backfill**

**Note:** Due to difficulties with quality control of mixture, safety, and time concerns related to accessing the pipeline for future maintenance, it is not recommended that a cement slurry or CLSM be used as pipe shading material.

## 6.1. Slurry Cement and/or CLSM (including soil cement CLSM)

- A. Slurry cement or CLSM must not be used as a shading material unless approved by the responsible design or asset engineer in the IFC drawing or through the field change control process.
- B. **Do not** allow cement additives such as calcium oxide (quicklime) to come into contact with PE pipe, tubing, or fittings.

**Gas Trench Design and Construction****A-03****Publication Date:** 08/19/2020 **Effective Date:** 11/16/2020 **Rev.** 0a

## 6.1 (continued)

- C. The design engineer can work with concrete vendors or construction contractors to develop suitable low strength slurry mix design and quality control requirements.
  - (1) In order to allow for manual excavation of buried facilities, a mix with a maximum design compressive strength of 50 pounds per square inch (psi) is required.
  - (2) Refer to American Concrete Institute (ACI) 229R-99, "Controlled Low-Strength Materials" for examples of CLSM mixture portions.
- D. The responsible design or asset engineer working with the project team and corrosion services has sole authority to approve a slurry or concrete with a compressive strength over 50 psi used as a protective cap for shallow pipe.
  - (1) Place a minimum of 12 inches of sand or fine material between the pipe and concrete cap.
  - (2) Redline as-built drawing or GSR where the pipe has a slurry backfill or concrete cap.

## 6.2. 0-Sack Slurry (a.k.a. wet sand)

- A. When using wet sand (0-sack slurry) for backfill, a minimum dry time of 24 hours is required before placing final fill.
- B. The use of wet sand (0-sack slurry) as a backfill in the following locations requires design or asset engineer approval:
  - (1) Locations with a high groundwater table or high hydraulic gradient.
  - (2) Locations where ground settlement over time is a concern.
  - (3) In trenches where the native material is not free-draining, for example, soils with high clay and silt content.
- C. Sand used in 0-sack slurry must meet the requirements in EMS-4123 with the following additions:
  - (1) The sand must be washed and free of fine organic silts and clays.
  - (2) Sand equivalent equal to or greater than 20 per ASTM D-2419-14, "Standard Test Method for Sand Equivalent Value of Solid and Fine Aggregate."
- D. In a trench that contains voids, consider using a concrete vibrator to assist with consolidation under pipe and voids created by shoring removal, etc.

**Gas Trench Design and Construction****A-03****Publication Date:** 08/19/2020 **Effective Date:** 11/16/2020 **Rev.** 0a

---

## 6.2 (continued)

## E. Testing

- (1) When required to be tested, 0-sack slurry must be tested using the following tests:
  - a) ASTM D-1557, "Laboratory Compaction Characteristics of Soil Using Modified Effort" or equivalent.
  - b) ASTM D6938-15, "Standard Test Methods for In-Place Density and Water Content of Soil and Soil-Aggregate by Nuclear Methods (Shallow Depth)."

**Target Audience**

The following personnel: gas transmission and distribution (T&D) construction, gas T&D general construction, gas engineering and design, gas transmission engineering and design, gas distribution engineering and design, gas maintenance and construction, gas T&D pipeline operations and maintenance, DIMP engineering, TIMP pipeline services, and facility integrity management program (FIMP) plant services.

**Definitions**

NA

**Compliance Requirement / Regulatory Commitment**

California Public Utilities Code, Article 3, Equipment, Practices, and Facilities, Section 787

Code of Federal Regulations (CFR) Title 49, Transportation, Part 192—Transportation of Natural and Other Gas by Pipeline: Minimum Federal Safety Standards, Section 192.319, "Installation of pipe in a ditch."

*cited in Cal. Rest. Ass'n v. City of Berkeley  
No. 21-16278am archived December 27, 2023*

**Gas Trench Design and Construction****A-03****Publication Date:** 08/19/2020 **Effective Date:** 11/16/2020 **Rev.** 0a

---

**References**

American Concrete Institute (ACI) 229R-99 Controlled Low-Strength Materials

American Society for Testing and Materials (ASTM) D2488-09a, "Standard Practice for Description and Identification of Soils (Visual-Manual Procedure)"

ASTM D698-12, "Standard Test Methods for Laboratory Compaction Characteristics of Soil Using Standard Effort"

ASTM D1557-12, "Standard Test Methods for Laboratory Compaction Characteristics of Soil Using Modified Effort"

ASTM C136-14, "Standard Test Method for Sieve Analysis of Fine and Coarse Aggregates"

ASTM D2487-11, "Standard Classification of Soils for Engineering Purposes (Unified Soil Classification System)"

ASTM G51-95, "Standard Test Method for Measuring pH of Soil for Use in Corrosion Testing"

ASTM D4972-13, "Standard Test Method for pH of Soils"

ASTM D6938-15, "Standard Test Methods for In-Place Density and Water Content of Soil and Soil-Aggregate by Nuclear Methods (Shallow Depth)"

A.W. Peabody, Control of Pipeline Corrosion, Second Edition (National Association of Corrosion, 2001)

Caltrans Construction Manual – 2014

California Department of Transportation (Caltrans) Corrosion Guidelines Version 2.0, November 2012

Engineering Material Specification EMS-4123, "Backfill Sand"

Gas Design Standard A-04, "Cover and Clearance Requirements for Transmission Lines, Distribution Mains and Service Lines"

Gas Design Standard L-16, "Gas Pipeline Underground Warning Tape"

Performance Pipe Engineering Manual, Chevron Phillips Chemical Company, 2003

Utility Manual TD-4621M, "Excavation Safety Manual"

Utility Procedure TD-4412P-05, "Excavation Procedures for Damage Prevention"

Utility Standard S5453, "Joint Trench"



**Gas Trench Design and Construction****A-03****Publication Date:** 08/19/2020 **Effective Date:** 11/16/2020 **Rev.** 0a

---

**Appendices**

NA

**Attachments**

NA

**Revision Notes**

Revision 0a has the following changes:

1. For Placement and Compaction, updated guidance for bedding compaction and added specific guidance for plastic installations.
2. For Slurry and Controlled Low Strength Material (CLSM), updated the approval requirements for the use of CLSM as shading. Added specific guidance for plastic installations. Clarified the requirements for CLSM to have a maximum design compressive strength of 50 pounds per square inch. Added the requirement for a minimum dry time of 24 hours for wet send (0-sack slurry) use. Clarified the guidance for locations that require approval for the use of wet sand as a backfill material.

Revision 0 (Publication Date: 08/16/2017, Effective Date: 08/30/2017) has the following changes:

1. This is a new GDS.

**Asset Type:** Storage, Compression & Processing, Measurement & Control, Transmission Pipe, Distribution Mains, Distribution Services, Customer Connected Equipment, CNG/LNG.**Function:** Design, Construction, Maintenance, Operation, and Emergency Response**Document Contact:** [Gas Design Standard Responsibility List](#)



**GAS DESIGN STANDARD**  
**COVER AND CLEARANCE REQUIREMENTS FOR**  
**TRANSMISSION LINES, DISTRIBUTION MAINS, AND**  
**SERVICE LINES**

A-04

Publication Date: 07/24/2021 Effective Date: 10/01/2021 Rev. 0d

### Purpose and Scope

This Gas Design Standard (GDS) establishes minimum cover and clearance requirements for Pacific Gas and Electric Company (Company) buried gas transmission lines, gas distribution mains, and gas service lines that do not cross highways or railroads. Its purpose is for public safety and to meet all governmental and other requirements. These cover and clearance requirements are applicable to the installation of new, replaced, or relocated gas facilities. This GDS also discusses minimum clearances by facility type.

### General Information

1. The cover and clearance requirements in this GDS meet or exceed the minimum requirements established in Code of Federal Regulations 49 (CFR) Part 192, "Transportation of Natural and Other Gas by Pipeline: Minimum Federal Safety Standards," and CPUC General Order (G.O.) 112-F, "State of California Rules Governing Design, Construction, Testing, Operation, and Maintenance of Gas Gathering, Transmission, and Distribution Piping Systems."
  - A. Additional cover or clearances may be required where conditions warrant, as well as to meet any additional requirements contained in right-of-way documents.
  - B. In instances where it is impractical to provide these minimum cover and clearances, or where damage from external loading must be prevented, the local engineer must ensure pipe is cased or protected by a permanent bridging structure which will handle any anticipated loading as described in 49 CFR 192.327, "Cover." For these conditions for transmission pressure facilities, refer to Utility Procedure TD-4813P-01, "Gas Transmission Pipelines Reduced Cover Evaluation" for further guidance.
2. All approvals for reduced cover and clearance must be documented in an approved project management tool. If one approval covers multiple projects, then the approval must be recorded in the project management tool for each individual project.
3. Refer to Interim Standard 463-3, "Gas Pipe Crossing of State Highways and Freeways" for minimum cover requirements for highway crossings.
4. Refer to GDS A-70, "Casings for Highway and Railroad Crossings" for specifications and illustrations of casings for highways and railroad crossings.

## Cover and Clearance Requirements for Transmission Lines, Distribution Mains, and Service Lines

A-04

Publication Date: 07/24/2021 Effective Date: 10/01/2021 Rev. 0d

5. For existing steel pipelines (transmission, distribution main, or service) found to have less than 6 inches radial clearance from metallic structures not associated with the steel pipeline, the following requirements apply:
  - A. Before backfilling the excavation, the steel pipeline must be protected by doing one of the following, in order of preference:
    - (1) Relocate steel pipeline to minimum clearances listed in the Clearance Requirements section of this GDS.
    - (2) Install at least one sheet of Delrin (material code M569264) as close as possible to the metallic structure.
    - (3) Install Rockguard or Tuff N Nuff between the steel pipeline and the metallic structure per GDS E-35.9, "Coating Protection Systems for Harsh Backfill Environments."
  - B. If steel pipeline parallels the metallic structure, it is only necessary to protect the pipe within the extent of the original excavation. Create a CAP issue for integrity management to track and prioritize the remaining steel pipeline with reduced clearance.
6. These cover and clearance requirements are applicable to the installation of new, replaced, or relocated gas facilities. The requirements are not retroactive to existing facilities which have less than the specified cover or clearance, either because they were installed prior to the adoption of applicable governmental regulations or because the cover was reduced after the main or service line was installed. However, where an existing line is found to have cover or clearance less than that specified by 49 CFR Part 192, consult with appropriate gas engineering personnel or supervisor and reference 49 CFR 192.327 for additional cover requirements. Also, some right-of-way and permit documents require the Company to maintain a minimum cover over a pipeline. Where such a requirement exists, it must be complied with.

### Cover Requirements

#### 1. Transmission Facilities

- A. Minimum cover for buried gas transmission facilities are specified in Table 1.

**Table 1. Minimum cover for gas transmission facilities by Class location**

Class	Normal Soil Minimum Cover (Inches)	Consolidated Rock Minimum Cover (Inches)
1	30	18
2	36	24
3	36	24
4	36	24

## Cover and Clearance Requirements for Transmission Lines, Distribution Mains, and Service Lines

A-04

Publication Date: 07/24/2021 Effective Date: 10/01/2021 Rev. 0d

### B. Notes on Minimum cover for buried gas transmission facilities:

- (1) Where an underground structure prevents the installation of a transmission line with the minimum cover, the transmission line may be installed with less cover per the requirements stated in 49 CFR 192.327, and Utility Procedure TD-4813P-01.
  - a) Before installing transmission line at less than minimum cover, responsible engineer must document in an approved project management tool the underground structure, the additional protection being used, and the rationalization or any calculations done to show the additional protection was sufficient.
- (2) All pipe installed in a navigable river, stream, or harbor must be installed with a minimum cover of 48" in soil or 24" in consolidated rock between the top of the pipe and the underwater natural bottom (as determined by recognized and generally accepted practices).
- (3) In areas where grading or erosion are anticipated or farming or other operations which might result in deep plowing could occur, a minimum of 42" of cover must be provided over buried transmission lines. Deep plowing is plowing at depths greater than 8".
- (4) In areas where subsoiling activity is anticipated a minimum of 48" of cover must be provided. Subsoiling is plowing or turning up the subsoil. If there are indications of any other activity that would adversely affect a pipeline installed with the cover specified or that could reduce the cover in the future, additional cover must be provided as appropriate.
- (5) Minimum cover for a transmission line in or crossing drainage ditches of public roads and railroad crossings must be 36", except where greater depths are required by Interim Standard 463-3.

## 2. Gas Distribution Main Facilities

- A. Minimum cover for buried gas distribution main facilities are specified in Table 2.

**Table 2. Minimum Cover for Gas Distribution Main Facilities by Location**

Location	Minimum Cover (Inches)
Streets and Roads not designated as State Highways and Freeways, Private rights-of-way, Sidewalks, Private Property	24
Crossing of state highways and freeways	See GDS A-70
Joint Trench	For all joint trench requirements, see Utility Standard S5453, "Joint Trench".

## Cover and Clearance Requirements for Transmission Lines, Distribution Mains, and Service Lines

A-04

Publication Date: 07/24/2021 Effective Date: 10/01/2021 Rev. 0d

### B. Notes on Minimum cover for buried gas distribution main facilities:

- (1) Where an underground structure prevents the installation of a main with the minimum cover, the main may be installed with less cover per the requirements stated in 49 CFR 192.327. When installing under these conditions, local engineer to document reason for cover on job drawings.
- (2) In areas where grading or erosion are anticipated or farming or other operations which might result in deep plowing could occur, a minimum of 42" of cover must be provided over mains. Deep plowing is plowing at depths greater than 8". In areas where subsoiling activity is anticipated, a minimum of 48" of cover must be provided. Subsoiling is plowing or turning up the subsoil.
- (3) All pipe installed in a navigable river, stream, or harbor must be installed with a minimum cover of 48" in soil or 24" in consolidated rock between the top of the pipe and the underwater natural bottom (as determined by recognized and generally accepted practices).
- (4) Sufficient additional cover must be provided for the main to permit 24" of cover for services tapped off the main.
- (5) INSERTS: Where an existing main is replaced by insertion, the pipe used as a casing must have a minimum of 24" of cover.
- (6) Where a main being replaced by insertion does not have the required cover except where the main is subject to the conditions of Interim Standard 463-3, the local senior engineer must determine whether the existing pipe can provide the additional protection from anticipated external loads, as required by 49 CFR 192.327.
- (7) Note that cover requirements in Utility Standard S5453 apply to proposed joint trenches. Installations that are adjacent to a joint trench but are not in the joint trench do not follow joint trench requirements in Utility Standard S5453.

### 3. Service Lines

- A. Minimum cover for buried gas service lines are specified in Table 3.

**Table 3. Minimum cover for Gas Services by Location**

Location	Minimum Cover (Inches)
Gas Only Trench	24
Joint Trench	For minimum cover, see Utility Standard S5453.

**Cover and Clearance Requirements for Transmission Lines,  
Distribution Mains, and Service Lines****A-04**

Publication Date: 07/24/2021 Effective Date: 10/01/2021 Rev. 0d

**B. Notes on Minimum cover for buried gas service lines:**

- (1) Where a plastic or steel service is to be installed off an existing main which has 24" of cover or less, the service must be installed so that the section of pipe with less than 24" cover must be kept to a minimum. Cover over the service pipe under this condition must never be less than 18", unless special protection is provided.
- (2) Where an underground structure or other impeding condition prevents the installation of a service with the minimum cover shown in Table 3, then the local engineer may install the service with a minimum cover of 18". When installing at 18", local engineer to document reason on job drawings.
- (3) At the riser, the section of pipe which has 24" of cover or less must be kept to a minimum. This is accomplished by specifying:
  - a) IF the ground is level near the gas service riser,  
  
THEN use a standard riser and use dirt or sand to taper-up the slope with the servicing tubing, as close as practical to the riser. Adjusting the trench depth just prior to the riser is preferred over field bending of the riser for standard installations.
  - b) IF the ground slopes downward from the gas service riser,  
  
THEN use a standard riser. The riser can be bent in the field to adjust to the slope.
  - c) IF the ground slopes upward from the gas service riser,  
  
THEN use a short, prefabricated riser and dig a deeper trench. Taper-up the slope with service tubing. Do **not** bend the riser to match the slope.
- (4) Services Inserts: Where an existing service is replaced by insertion, the pipe used as a casing must have a minimum of 18" of cover. Where a service being replaced by insertion does not have the required cover except where the service is subject to the conditions of Interim Standard 463-3, the local senior engineer must determine whether the existing pipe can provide the additional protection from anticipated external loads, as required by 49 CFR 192.327.
- (5) Note that cover requirements in Utility Standard S5453 apply to proposed joint trenches. Installations that are adjacent to a joint trench but are not in the joint trench do not follow joint trench requirements.

**Cover and Clearance Requirements for Transmission Lines,  
Distribution Mains, and Service Lines****A-04**Publication Date: 07/24/2021 Effective Date: 10/01/2021 Rev. 0d

---

## 4. Notes on Cover that apply to all facilities

- A. Exceptional Cases: Contact the appropriate responsible gas engineering personnel to determine any additional appropriate cover requirements in the following cases:
- If there are indications of any other activity that would adversely affect a pipeline installed with the cover specified or that could reduce the cover in the future,
  - Where the additional cover requirement involves a substantial additional cost to the Company, notify the appropriate responsible gas engineering personnel.
  - Where consolidated rock soil conditions are encountered which make it not feasible to provide the cover specified above.
- B. Mitigations:
- Warning Tape per GDS L-16, "Gas Pipeline Underground Warning Tape."
- C. Additional Considerations: Additional cover should be provided where the potential for damage by outside forces is greater than normal. Consideration should be given to the following:
- Agricultural land where the grade may be changed to permit irrigation or drainage.
  - Other utility crossings. The new gas facilities should be installed under the existing facilities, unless adequate cover can be provided or casing, bridging, or other protection is used.
  - Locations where erosion due to wind, water, or vehicular activity may affect the grade. Riprap, paving, or some other means of protection may be used in lieu of additional cover.
  - Street locations where future street work is a possibility.
  - Locations where frost, drought, and heat might affect the pipeline.

**Clearance Requirements**

## 1. Joint Trench Requirements:

- A. For joint trenches, clearances are specified in Utility Standard S5453.
- B. Crossing Clearances from primary and secondary electric facilities as specified in Utility Standard S5453 Attachment 1 - "Detailed Procedures." For installations near primary electric lines, provide a minimum radial separation of 12". For installations near secondary electric lines, provide a minimum radial separation of 6".

## Cover and Clearance Requirements for Transmission Lines, Distribution Mains, and Service Lines

A-04

Publication Date: 07/24/2021 Effective Date: 10/01/2021 Rev. 0d

- 
- C. Follow Utility Standard S5453 Exhibit B - "Joint Trench Configurations and Occupancy Guide" for wet utility clearances.
2. Gas Transmission Lines:
- A. Minimum clearance between transmission lines and any other underground structure must be minimum 12".
- B. Adequate measures are undertaken to prevent contact between the pipeline and the underground structure, such as encasement of the pipeline with concrete, polyethylene or vulcanized elastomer, or the installation of sand-cement bags, concrete pads or open-cell polyurethane pads in the space between the pipeline and the underground structure.
- C. See Clearance Requirements Section 3.C. below.
- D. Clearance Requirements for Buildings
- (1) In all cases that allow, install all new transmission lines a minimum horizontal clearance of at least 10 feet from the face (or foundation) of any building. This distance reduces the risk of stresses caused by external building loads due to the transmission line being installed within 10 feet of the face (or foundation) of any building.
- a) In cases that do not allow a minimum horizontal clearance of at least 10 feet from the face (or foundation) of any building, the responsible gas engineer must review and approve.
- b) When installing a transmission line less than 10 feet from the face of a building, consider the following design options. Note that these are considerations only: Each transmission line that is being installed less than 10 feet from the face of a building must be individually reviewed and approved.
- Consider installing the pipeline in casing next to the building.
  - Consider posting pipeline markers at either end of the building to warn excavators of the presence of a pipeline.
  - Consider future Grade 1 leak repair access.
  - Consider stresses caused by proximity of building foundation.
  - Consider length of service off of the main for EFV installation.
  - Ensure warning tape is installed per GDS L-16.



## Cover and Clearance Requirements for Transmission Lines, Distribution Mains, and Service Lines

A-04

Publication Date: 07/24/2021 Effective Date: 10/01/2021 Rev. 0d

### 3. Gas Distribution Mains and Services:

- A. For independently installed buried distribution main and service lines (not in a joint trench), minimum clearances are specified in Table 4.

**Table 4. Minimum Clearance for Gas Distribution Mains and Service Lines by Facility Type**

Facility	Minimum Parallel Clearance	Minimum Crossing Clearance
Electric primary supply systems	12 inches <sup>1</sup>	
Electrical secondary supply systems and communication systems	12 inches	6 inches
Government- or utility-owned water or sewer facilities, drain or leach lines, or agriculture irrigation	3 feet <sup>2</sup>	6 inches
Diesel or other volatile liquids; propane or other volatile, heavier-than-air gases	3 feet	6 inches
Steam lines from plastic PG&E gas pipelines	10 feet <sup>3</sup>	
Any other heat source from plastic PG&E gas pipelines	Contact responsible engineer	
Any other pipe systems or other foreign substructures not listed above	12 inches	6 inches

- The minimum clearances can increase depending on the size of the electrical facility. The appropriate responsible gas engineering personnel must be consulted.
- For services only: if the 3-foot parallel clearance cannot be maintained, the clearance can be reduced to 12 inches. If 12 inches of clearance cannot be maintained, the service must be inserted in an existing facility or casing. The house side of the casing must be sealed per GDS A-73, "Casing Insulator and End Seals Selection Chart."
- Refer to GDS A-98, "Polyethylene Pipe Specifications and Design Considerations," if 10 feet cannot be met.

- B. Where an underground structure prevents the installation of a distribution main or service line with the minimum clearance shown in Table 4, the responsible engineer may approve installing the distribution main or service line with less clearance.

(1) When installing with less clearance, document reason for less clearance, mitigation methods used to protect the distribution main or service line, and responsible engineer approval in approved project management tool.

- C. When installing plastic pipelines by trenchless excavation, design sufficient clearance for installation and maintenance activities from other underground utilities and structures at the time of installation.

(1) Install per Utility Manual TD-4135M, "Horizontal Direction Drilling Manual," and Utility Manual TD-4170M, "Gas Transmission and Distribution Manual: Plastic Volume."

## Cover and Clearance Requirements for Transmission Lines, Distribution Mains, and Service Lines

A-04

Publication Date: 07/24/2021 Effective Date: 10/01/2021 Rev. 0d

- 
- D. The following possible activities should be considered when determining the clearance to be attained between the main being installed and other underground structures.
- Installation and operation of maintenance and emergency control devices, such as leak clamps, pressure control fittings, and squeeze-off equipment.
  - Connection of service laterals to both the main and other underground structures.
  - For additional methods of protection in lieu of sufficient clearance, see Section 2.B above.
- E. Each main must be installed with enough clearance from any other underground structure to allow proper maintenance and to protect against damage that might result from proximity to other structures.
- F. Install all new distribution mains a minimum horizontal clearance of at least 5 feet from the face (or foundation) of any building.
- (1) In cases that do not allow a minimum horizontal clearance of at least 5 feet from the face (or foundation) of any building, the responsible gas engineer must review and approve. When installing a distribution main less than 5 feet from the face of a building, consider the design options listed in Step 2.D above.
- G. In addition to meeting the requirements above, each plastic main must be installed with sufficient clearance, or must be insulated, from any source of heat so as to prevent the heat from impairing the serviceability of the pipe.
4. In all cases that allow, install all new services at a minimum parallel horizontal clearance that is equal to or greater than the buried depth of the service from the face (or foundation) of any building. For example, if the service is at a depth of 24", then the service must be at least 24" from the face of the foundation when parallel.
5. Each pipe-type or bottle-type holder must be installed with a minimum clearance from any other holder as prescribed in 49 CFR 192.175(b), "Pipe-type and bottle-type holders."
6. Third Party encroachment requirements:
- A. A Minimum of 12" undisturbed soil clearance applies to any non-utility facilities installed by a third party encroaching on Company rights-of-way or property. Where proper clearance cannot be attained as specified, other suitable precautions must be taken to protect the pipe, such as the installation of additional insulating material, bridging, or casing.

### Records

1. Retain records per the Record Retention Schedule.

## Cover and Clearance Requirements for Transmission Lines, Distribution Mains, and Service Lines

A-04

Publication Date: 07/24/2021 Effective Date: 10/01/2021 Rev. 0d

### Target Audience

Gas estimating, gas distribution engineering and design, gas construction, gas transmission engineering and design, land department

### Definitions

See Utility Standard TD-4125S, " Maximum Allowable Operating Pressure Requirements," for the definitions of transmission line, distribution main, and service line.

Pipeline: A pipeline that transports gas from a common source of supply to a customer meter set.

### Acronyms and Abbreviations

CFR: Code of Federal Regulations

GDS: Gas Design Standard

### Compliance Requirement / Regulatory Commitment

Code of Federal Regulations (CFR) Title 49, Transportation of Natural and other Gas by Pipeline: Minimum Federal Safety Standards, Section 192.175, "Transportation of Natural and Other Gas by Pipeline: Minimum Federal Safety Standards"

Code of Federal Regulations (CFR) Title 49, Transportation of Natural and other Gas by Pipeline: Minimum Federal Safety Standards, Section 192.3, "Definitions"

Code of Federal Regulations (CFR) Title 49, Transportation of Natural and other Gas by Pipeline: Minimum Federal Safety Standards, Section 192.175(b), "Pipe-type and bottle-type holders"

Code of Federal Regulations (CFR) Title 49, Transportation of Natural and other Gas by Pipeline: Minimum Federal Safety Standards, Section 192.325, "Underground clearance"

Code of Federal Regulations (CFR) Title 49, Transportation of Natural and other Gas by Pipeline: Minimum Federal Safety Standards, Section 192.327, "Cover"

Code of Federal Regulations (CFR) Title 49, Transportation of Natural and other Gas by Pipeline: Minimum Federal Safety Standards, Section 192.329, "Installation of plastic pipelines by trenchless excavation"

Code of Federal Regulations (CFR) Title 49, Transportation of Natural and other Gas by Pipeline: Minimum Federal Safety Standards, Section 192.361, "Service lines: Installation"

Code of Federal Regulations (CFR) Title 49, Transportation of Natural and other Gas by Pipeline: Minimum Federal Safety Standards, Section 192.376, "Installation of plastic service lines by trenchless excavation"

California Public Utilities Commission (CPUC) General Order (GO) 112-F

Printed copies of this document might be out-of-date. The Technical Information Library (TIL) has the current version.

**Cover and Clearance Requirements for Transmission Lines,  
Distribution Mains, and Service Lines****A-04**Publication Date: 07/24/2021 Effective Date: 10/01/2021 Rev. 0d

---

*Records and Information Management:*

Information or records generated by this procedure must be managed in accordance with the Enterprise Records and Information (ERIM) Policy, Standards and Enterprise Records Retention Schedule (ERRS). Refer to GOV-7101S, "Enterprise Records and Information Management Standard," and related standards. Management of records includes, but is not limited to:

- Integrity
- Storage
- Retention and Disposition
- Classification and Protection

**References**

GDS A-70, "Casings for Highway and Railroad Crossings"

GDS E-35.9, "Coating Protection Systems for Harsh Backfill Environments"

GDS L-16, "Gas Pipeline Underground Warning Tape"

I.S. 463-3, "Gas Pipe Crossing of State Highways and Freeways"

S5453, "Joint Trench"

S55453 Attachment 1, "Detailed Procedures"

S5453 Exhibit B, "Joint Trench Configurations and Occupancy Guide"

TD-4813P-01, "Gas Transmission Pipelines Reduced Cover Evaluation"

**Appendices**

NA

**Attachments**

NA

**Cover and Clearance Requirements for Transmission Lines,  
Distribution Mains, and Service Lines****A-04**

Publication Date: 07/24/2021 Effective Date: 10/01/2021 Rev. 0d

**Revision Notes**

Revision 0d has the following changes:

1. New step General Information 5. to provide guidance for existing installations on appropriate minimum distance or protection between gas transmission and distribution assets and metallic structures or protection of existing installations when observed (CAPn issue 120472529 CA-1)
2. Added reference to definitions in TD-4125S.
3. Removed definitions of gas distribution main and transmission line.

Revision 0c has the following changes:

1. For transmission clearances, replaced reference to building clearances in distribution section with existing content.
2. For distribution clearances, replaced reference to Utility Standard S5453 for minimum clearances with Table 4, and moved clearances between plastic pipe and source of heat from existing step to Table 4. Added approval process if minimum clearances not practical, and updated minimum clearances from face (or foundation) of a building.

Revision 0b has the following changes:

4. Updated reference to CPUC G&E 112-F.
5. Added process for transmission lines to be installed with less cover if it is provided with additional protection to withstand anticipated external loads.
6. Clarified main and service insert minimum cover requirements and process for if existing pipe used as a casing can provide adequate protection from anticipated external loads.
7. Added directions for when the standard riser depth does not meet the "at a minimum" requirements (CAPN 115523642).
8. Clarified that clearances from underground structures and underground utilities in the joint trench standard and apply to independently installed distribution main and services.
9. Added requirements for plastic pipelines installed by trenchless excavation (ECTS 508688)
10. To align with the transmission line definition change, plastic pipe requirements apply to transmission lines as well.

Revision 0a has the following changes:

1. Added section Records.

**Cover and Clearance Requirements for Transmission Lines,  
Distribution Mains, and Service Lines****A-04****Publication Date:** 07/24/2021 **Effective Date:** 10/01/2021 **Rev.** 0d

---

Revision 0 has the following changes:

1. Converted document from Utility Standard S463-4 to Gas Standard and Specifications (Gas Design Standard).
2. Converted document from Utility Standard S463-4 to Gas Standard and Specifications (Gas Design Standard).
3. Converted the term "standard" to "Gas Design Standard" where appropriate. 4. Added items to cover 49 CFR 192.325, 49 CFR 192.327, 49 CFR 192.361.
4. Clarified cover requirements for Gas Mains and Gas Services.
5. Added clearance requirements for buildings.
6. This design standard is part of Change 67.

**Asset Type:** Gas Transmission and Distribution

**Function:** Design

**Document Contact:** [Gas Design Standard Responsibility List](#)

*cited in Cal. Rest. Ass'n v. City of Berkeley  
No. 21-16278am archived December 27, 2023*

cited in Cal. Rest. Ass'n v. City of Berkeley  
No. 21-16278am archived December 27, 2023



## GAS DESIGN STANDARD STANDARD BRANCH SERVICE INSTALLATION

A-42

Publication Date: 10-09-13 Rev. #03

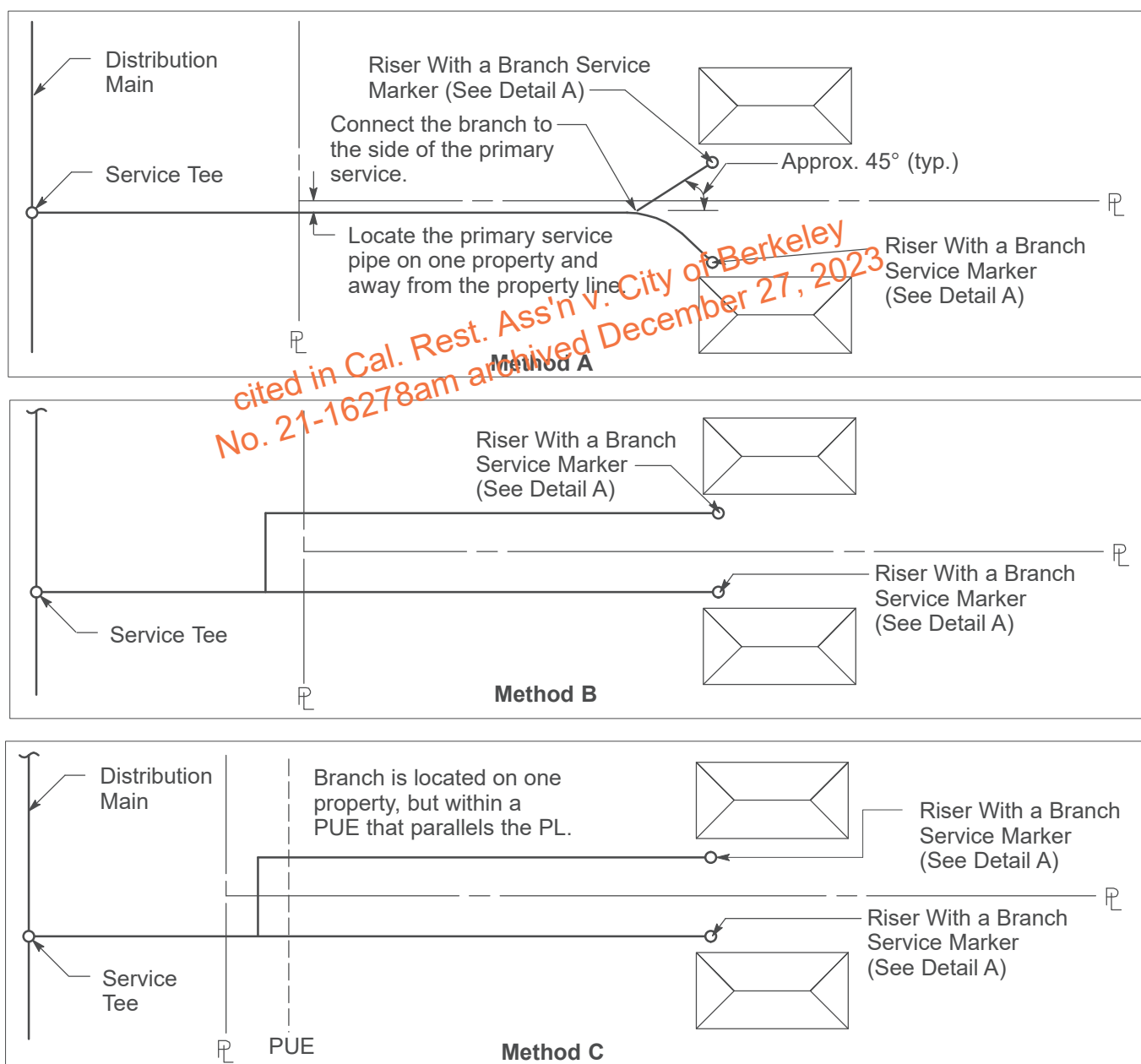
This document also appears in the following manual:

- [Gas Applicant Design Manual](#)

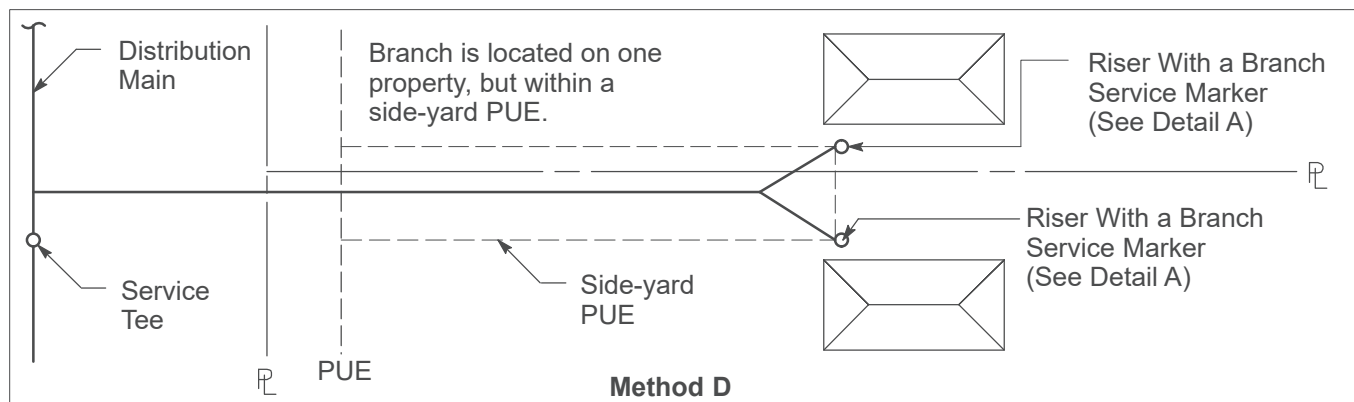
### Purpose and Scope

This gas design standard illustrates approved methods of standard branch service installation and shows the approved branch service marker.

### Methods of Installation







### General Information

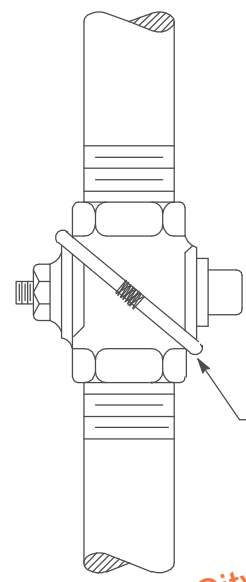
1. Branching is at PG&E's discretion.
2. Install plastic services in accordance with [Gas Design Standard A-90, "Plastic Main and Service Installation."](#)
3. For stub services, install EMS markers in accordance with [Gas Design Standard A-90.2, "Locating Wire Installation for Direct Burial Plastic Mains and Services"](#) and [Gas Design Standard M-60, "Approved "Mark and Locate" Instruments, Equipment, Accessories, and Products."](#)

### Notes on Methods of Installations A-D:

1. Replacement of Existing Branch Services
  - a. Method A is the preferred approach for the replacement of an existing branch service for configurations that are similar to Method A. The reasons include:
    - Permission has been previously obtained at this location, based on the presence of the existing branch service.
    - Use of existing branch service locations generally helps reduce costs and minimizes impact to customer.
  - b. If the customer disagrees with the location of the branch across their property line, then use Method B.
2. Installation of New Branch Services
  - a. Method B, C, and D are acceptable options for the design and installation of a new branch service. Branches shown in Method C and D will require a public utility easement (PUE). A PUE is required for any new branch originating inside a property line to serve an adjacent property.
3. Residential Subdivisions:
  - a. For new business, if the applicant chooses Method D, then a side-yard PUE will be required. Currently, Method C is most commonly used in subdivisions.
4. Exceptions to branching across property lines:
  - a. If the property owner disagrees with the branch location or if an easement cannot be secured from the property owner, then the branch service will need to be installed outside the property line or new services must be installed.

**Branch Service Marker**

- Option 1.** A marker made of 3/16" bronze rod, Airco #27 or similar (Code 159064) is formed into an elliptical ring and brazed closed. Do not heat the valve body. Use wet rags to keep the valve body cool when making the marker.
- Option 2.** A marker made of #8, #10, or #14 copper wire is formed around the cock and secured with a Burndy Hylink connector, or twisted and forged to a solid connection.



Branch Service Marker.  
To be installed on each  
branch service over the  
service cock as shown.  
Use Option 1 or 2 as  
preferred.

Detail A.  
Branch Service Marker

*cited in Cal. Res. Ass'n City of Berkeley  
No. 21-16278am archived December 27, 2023*

**Target Audience**

Gas estimating, gas distribution engineering and design, gas construction, land department

**Definitions**

NA

**Acronyms and Abbreviations**

PL: Property Line  
PUE: Public Utility Easement

**Compliance Requirement/Regulatory Commitment**

NA

**References**

[Plastic Main and Service Installation](#) ..... [A-90](#)  
[Locating Wire Installation for Direct Burial Plastic Mains and Services](#) ..... [A-90.2](#)  
[Approved "Mark and Locate" Instruments, Equipment, Accessories, and Products](#) ..... [M-60](#)  
[Gas Applicant Design Manual](#)

**Appendices**

NA

**Attachments**

NA

**Revision Notes**

Revision 03 has the following changes:

1. Added Notes for Replacement of Existing Branch Services and for Installation of New Branch Services.
2. Added Notes for Subdivisions.
3. Added Exceptions.
4. Added Method C and D. Reversed order of A and B.
5. This document is part of Change 66.

*cited in Cal. Rest. Ass'n v. City of Berkeley  
No. 21-16278am archived December 27, 2023*

**Asset Type:** Gas Transmission and Distribution

**Function:** Design

**Document Contact:** [Gas Design Standard Responsibility List](#)



## GAS DESIGN STANDARD CURB VALVES

**A-43.2**

Publication Date: 04/15/2020 Effective Date: 07/15/2020 Rev. 5

### Purpose and Scope

This gas design standard (GDS) provides requirements and installation instructions for service valves installed in curb areas. Curb valves are to be installed in accordance with Code of Federal Regulations (CFR) Title 49, Transportation, Part 192—Transportation of Natural and Other Gas by Pipeline: Minimum Federal Safety Standards, Section (§) 192.385, “Manual service line shut-off valve installation.”

### 1 Installation Guidelines

- 1.1. Use an excess flow valve (EFV) instead of, or in addition to, a curb valve, when feasible. See GDS A-93.3, “Excess Flow Valves,” and criteria in Step 1.2 for additional information.
- 1.2. Use a curb valve on every new or replaced service line when any of the following conditions exist:
  - A. The total meter capacity exceeds 1000 standard cubic feet per hour, and an EFV is not required and not installed.
    - (1) Valves meeting the above criteria are critical isolation valves. See Attachment 1, “Installation Guidance” for additional guidance and requirements.
  - B. The service riser valve is not readily accessible or is inside a building, such as where the service shutoff valve is enclosed (e.g., basement, garage, or other type of obstructed location).
  - C. The service line supplies a building where approximately 100 or more people gather and where the occupancy may be transient. Examples include but are not limited to schools, hospitals, churches, places of incarceration, theaters, and transit centers.
  - D. The service line cannot be quickly squeezed off due to wall-to-wall paving, concrete, depth of cover, or other surface conditions and an EFV is not required and not installed. This includes known planned depth of cover or other surface conditions. Typically, a service line that is installed in a lawn area with normal soil conditions (e.g., no wall-to-wall paving, concrete, or other obstruction over the service line) may be quickly squeezed off.
- 1.3. Install curb valve at least 5 feet from any building, as close to the property line and gas main as practical, and in a location that should minimize the chances the valve will be paved over, or access obstructed.
- 1.4. Install valves using components listed in [Table 1](#).
  - A. Follow all instructions shown in GDS A-90.2, “Locating Wire Installation for Plastic Mains and Services.”

**Curb Valves****A-43.2****Publication Date:** 04/15/2020 **Effective Date:** 07/15/2020 **Rev. 5**

## 1.4 (continued)

B. IF the curb valve installed is a critical isolation valve (Step 1.2.A.),

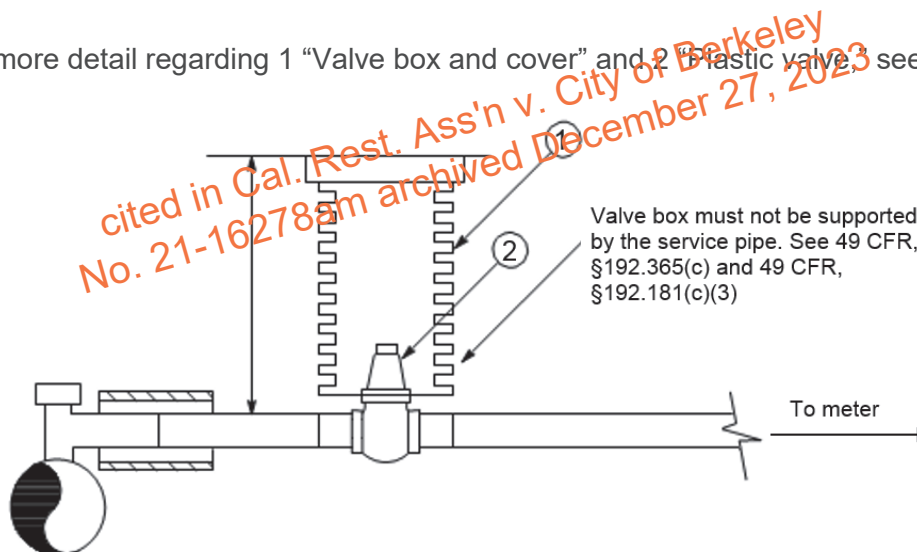
THEN follow additional guidance shown in Attachment 1.

(1) Critical isolation valves must be installed with a valve extension.

**Table 1. Components for Curb Valve Installations**

Item	Material Specifications and Installation Guidance	
1	Valve box and cover	For sidewalk or other areas not normally subjected to traffic, or in paved areas where a grade change is likely, see GDS K-40, "Plastic Valve Box for 3/4" – 4" Valves."
	Valve box and cover	For traffic areas or where grade adjustability is required, see GDS K-41, "Concrete Valve Box – Street Installation on 2" to 4" Gas Mains Incl."
	Valve box and cover	Installation of boxes is shown in GDS K-40.1, "Method of Installing Concrete Curb Boxes in Concrete Sidewalk," and GDS K-41.1, "Typical Installation of Traffic Valve Box on 2" to 4" Gas Mains Incl."
2	Plastic valve	For appropriate plastic valve and extension, see GDS F-90, "Polyethylene (PE) Valves."

1.5. For more detail regarding 1 "Valve box and cover" and 2 "Plastic valve" see Figure 1.

**Figure 1. Curb Valve Installation, Distribution System**

1.6. IF a curb valve is installed,

THEN complete the following steps:

- A. Complete the gas service record (GSR), per Utility Procedure TD-9500P-14, "Gas Service Records."
- B. Add an electronic marker system (EMS) marker to the curb valve installation location. Refer to GDS M-60, "Approved Locate and Mark Instruments, Equipment, Accessories, and Products."
- C. Map the information.
- D. Retain records per the Record Retention Schedule.

**Curb Valves****A-43.2****Publication Date:** 04/15/2020 **Effective Date:** 07/15/2020 **Rev.** 5**Target Audience**

Personnel in the following areas: gas distribution engineering, estimating, gas maintenance and construction (M&C), general construction (GC), distribution mapping, and new business inspection personnel. Personnel involved in distribution pipeline connection training and qualification programs.

**Definitions**

Curb valve	Valve installed on a service line, below grade, upstream of the riser valve.
Replaced service line	A gas service line where the fitting that connects the service line to the main is replaced or the piping connected to this fitting is replaced.
Service line	A distribution line that transports gas from a common source of supply to an individual customer, to two adjacent or adjoining residential or small commercial customers, or to multiple residential or small commercial customers served through a meter header or manifold. A service line ends at the outlet of the customer meter or at the connection to a customer's piping, whichever is further downstream, or at the connection to customer piping if there is no meter.

**Compliance Requirement / Regulatory Commitment**

Code of Federal Regulations (CFR) Title 49, Transportation, Part 192—Transportation of Natural and Other Gas by Pipeline: Minimum Federal Safety Standards, Section 192.181(c)(3), "Distribution line valves"

49 CFR, §Section 192.361(a), "Service lines: Installation"

49 CFR, §192.365(c), "Service lines: Location of valves"

49 CFR, §192.383(a), "Excess flow valve installation"

49 CFR, §192.385(b), "Manual service line shut-off valve installation"

**References**

Gas Design Standard A-90.2, "Locating Wire Installation for Plastic Mains and Services"

Gas Design Standard A-93.3, "Excess Flow Valves"

Gas Design Standard F-90, "Polyethylene (PE) Valves"

Gas Design Standard K-40, "Plastic Valve Box for 3/4" – 4" Valves"

Gas Design Standard K-40.1, "Method of Installing Concrete Curb Boxes in Concrete Sidewalk"

Gas Design Standard K-41, "Concrete Valve Box – Street Installation on 2" to 4" Gas Mains Incl."

Gas Design Standard K-41.1, "Typical Installation of Traffic Valve Box on 2" to 4" Gas Mains Incl."

**Curb Valves****A-43.2****Publication Date:** 04/15/2020 **Effective Date:** 07/15/2020 **Rev.** 5

---

## References (continued)

Gas Design Standard M-60, "Approved Locate and Mark Instruments, Equipment, Accessories, and Products."

Utility Procedure TD-9500P-14, "Gas Service Records"

**Appendices**

NA

**Attachments**

Attachment 1, "Installation Guidance"

**Revision Notes**

Revision 5 has the following changes:

1. Added information, Step 1.1 to encourage additional use of EFVs where ever feasible.
2. Updated wording in Step 1.2 to allow for reference of other procedures
3. Emphasized in Step 1.3 that consideration should be given to maintenance accessibility when choosing curb box location
4. Moved additional install guidance to Step 1.4 to add references to GDS A-90.2 and the new Attachment 1.
5. Added Attachment 1 to clarify Department of Transportation (DOT)-required installation and maintenance guidelines.
6. Added additional definitions and regulatory commitment information for clarity.
7. Added distribution mapping personnel to the Target Audience.

**Asset Type:** Distribution Services

**Function:** Design

**Document Contact:** [Gas Design Standard Responsibility List](#)



## GAS DESIGN STANDARD GAS SERVICE AND MAINS IN PLASTIC CASING

A-75

Publication Date: 03/23/2021    Effective Date: 03/23/2021    Rev. 2c

### Purpose and Scope

This gas design standard (GDS) describes the use and design of PE 2708 and PVC casing material for use in PG&E's gas distribution system. PG&E uses PE 2708 and PVC plastic casing material to facilitate the installation of gas mains and services in residential and commercial subdivisions and for select gas main replacement projects. See the manufacturer's product manuals and catalogs and the GDSs listed in the "References" section below for more information.

This document also appears in the following manuals:

- *Electric and Gas Service Requirements (Greenbook)*
- *Gas Applicant Design Manual*

### General Information

1. PE 2708 (MDPE) plastic casing material (sleeves and conduit) shall conform to Engineering Material Specification 2503 except as noted in Items 3 and 4 below.
2. PE 2708 casing material having SDRs not listed in Engineering Material Specification 2503 shall be tested and certified in accordance with ASTM D2513 - 18a.
3. PE 2708 casing material shall be yellow in color and marked with four orange stripes running the length of the casing. The width of the four orange stripes shall be 1/8" minimum for 2" IPS casing and shall increase proportionally with increases in the casing size. The orange stripes shall be equally spaced around the circumference of the casing.
4. PE 2708 casing material shall have a printline stating "Natural Gas Sleeve" (instead of "Gas") running the length of the casing. All other marking information, to include the spacing of printline marks, shall be provided in accordance with the requirements listed in Engineering Material Specification 2503.
5. PVC plastic casing material (conduit) shall conform to Engineering Material Specification 64.
6. PVC plastic casing material shall conform to Numbered Document 062288.
7. PE 2708 casing material is preferred for service conduits and gas main casings. Use company-approved conduit for casing material when PE 2708 casing is not available.
8. The sizes and wall thickness of PE 2708 and PVC casing material, as shown in [Table 1](#) on Page 2, are approved for use in the PG&E system. The use of other sizes, SDRs, and grades of PE 2708 and PVC casing material must have the prior approval of engineering personnel.



**Gas Service and Mains in Plastic Casing****A-75**

Publication Date: 03/23/2021 Effective Date: 03/23/2021 Rev. 2c

General Information (continued)

**Table 1. Approved PE 2708 and PVC Casings**

Size (IPS)	Material <sup>1</sup>	SDR	Typical Construction Methods	OD (Inches)	ID (Inches)	Length <sup>2</sup> (Feet)	Code	Wall Thickness (Inches)
2	PVC <sup>3,4</sup>	NA	Direct Bury (Stick)	2.375	2.161	20	016468	0.077
2	PE 2708	11	HDD (Stick) Direct Bury or Insert	2.375	1.917	20	021419	0.216
2	PE 2708	11	HDD (Coil)	2.375	1.917	500	021420	0.216
4	PVC <sup>3,4</sup>	NA	Direct Bury (Stick)	4.500	4.132	20	016472	0.154
4	PE 2708	13.5	HDD (Stick) Direct Bury or Insert	4.500	3.830	40	021421	0.333
4	PE 2708	13.5	HDD (Coil)	4.500	3.830	400	021422	0.333
6	PVC <sup>3,4</sup>	NA	Direct Bury (Stick)	6.625	6.111	20	016474	0.227
6	PE 2708	13.5	HDD (Stick) Direct Bury or Insert	6.625	5.643	40	021423	0.491
6	PE 2708	13.5	HDD (Coil)	6.625	5.643	400	021424	0.491
8	PE 2708	13.5	Direct Bury or Insert (Stick)	8.625	7.347	40	021425	0.639
12	PE 2708 <sup>5</sup>	13.5	HDD (Stick) Direct Bury or Insert	12.750	10.862	40	021426	0.945

<sup>1</sup> Minimum order quantities apply.<sup>2</sup> Lengths are for sticks or coils. Smaller lengths are for sticks and larger numbers are for coils.<sup>3</sup> Refer to [Numbered Document 062288](#) for material information and codes for couplings and PVC cement.<sup>4</sup> Do not use HDD to install PVC casings.<sup>5</sup> Size and dimensions not referenced in [Engineering Material Specification 2503](#). Dimensions shall conform to ASTM D2513 - 18a.**Application**

1. The installation of plastic casing material should not be used as a substitute for proper job scheduling for new business work.
2. The installation of PE 2708 or PVC gas main casings shall not be used to circumvent main line extension rules specified in [Gas Rule 15](#). PE 2708 or PVC main casings shall not be installed in any distribution trench, except under limited circumstances as stated in Items 3B and 3C below.

**Gas Service and Mains in Plastic Casing****A-75**

Publication Date: 03/23/2021 Effective Date: 03/23/2021 Rev. 2c

Application (continued)

3. PE 2708 and PVC casing material may be used to facilitate construction under limited circumstances.
  - A. PE 2708 or PVC service casings may be installed on new business work under any of the following circumstances:
    - (1) Paving of the property between the service stub and proposed meter site occurs before service completion.
    - (2) Completion of the gas service is impractical owing to the likelihood of damage to the service as a result of construction activities.
    - (3) The Company or applicant installer cannot meet the developer's construction scheduling requirements to construct the service completion.

**Note:** The applicant owns the empty service casing until a gas facility has been inserted and pressurized in accordance with Gas Rule 16. The applicant should be informed of the ownership requirements before construction. This includes the obligation to locate and surface mark the facility pursuant to a USA request and the responsibility to maintain serviceability of the casing and EMS devices. Do not install service casings in the public right of way.

- B. PE 2708 or PVC gas main casing material may be installed on new business work under either of the following circumstances:
  - (1) Paving of the street between an existing gas main and proposed gas main extension would occur before the distribution trench is constructed.
  - (2) Installation of the gas main is impractical owing to the likelihood of damage to the main as a result of construction activities.
- C. The installation of PE 2708 and PVC casings is limited to street crossings that do not traverse state highways or railroads. Refer to GDS A-70 for highway and railroad casing requirements.

**Note:** The applicant owns the empty casing until a gas facility has been inserted and pressurized in accordance with Gas Rule 15. The applicant should be informed of the ownership requirements before construction. This includes the obligation to locate and surface mark the facility pursuant to a USA request and the responsibility to maintain serviceability of the casing and associated appurtenances.

**Gas Service and Mains in Plastic Casing****A-75**

Publication Date: 03/23/2021 Effective Date: 03/23/2021 Rev. 2c

## Application (continued)

- D. PE 2708 gas main casing material may be installed on reconstruction work under any of the following circumstances:
- (1) The replacement method specified involves cast iron bursting or steel pipe splitting.
  - (2) The replacement method specifies using HDD to cross streets or thoroughfares other than state highways or railroads. Refer to GDS A-70 for highway and railroad casing requirements.
  - (3) Paving of the street between an existing gas main and proposed gas main extension occurs before the distribution trench is constructed.
  - (4) Installation of the gas main is impractical owing to the likelihood of damage to the main as a result of construction activities.
- E. PVC gas main casing material may be installed on reconstruction work on a case by case basis.
- F. PE 2708 and PVC gas main casing material may not be installed as a casing for PE pipe on bridges. Refer to GDS A-33.1 for PE casing requirements on bridge structures.
- G. PE 2708 and PVC gas main casing material may not be installed as a casing for steel mains or services.
- H. Gas mains and services shall not be inserted into existing service casings or gas main sleeves that do not meet the requirements of this GDS document unless approved by gas engineering personnel.
- I. Service casings and gas main sleeves installed on new business work are non-refundable items.
- J. If another utility or entity encroaches upon a service casing or gas main sleeve on a new business job, the applicant is responsible for providing an alternative trench or removing the other utility's or entity's facility before installing the gas main or service. Contact the rates and tariffs personnel for assistance in resolving these matters.
- K. If another utility or entity encroaches upon a gas main casing on a reconstruction job, contact the encroaching party and have them remove their facility. Contact Company legal personnel for assistance in these matters.
- L. The approval to install service and gas main casings shall be made before construction by gas engineering personnel.

**Gas Service and Mains in Plastic Casing****A-75**

Publication Date: 03/23/2021 Effective Date: 03/23/2021 Rev. 2c

**Limitations**

1. Do not install PE 2708 or PVC casing materials where operating temperatures exceed 140°F. Do not install PE 2708 or PVC casing materials within 10' of steam lines or other sources of heat, or at a distance such that the temperature on the PE 2708 or PVC casing materials could exceed 100°F, unless an insulating barrier is provided to ensure that the temperature of the PE 2708 or PVC casing materials is always below 100°F. Crossings of PE 2708 or PVC casing materials and steam lines are allowed if a thermal insulating barrier is provided and the 100°F temperature limit is maintained. Note: PVC casing material is rated at 194°F. However, the gas carrier pipe is limited to 100°F.
2. Do not install PE 2708 or PVC casing materials in aboveground locations, or where the material could be exposed to UV radiation. PE 2708 or PVC casing materials do not provide sufficient mechanical protection for aboveground installations.
3. Contact gas engineering personnel to assess chemical compatibility with PE 2708 or PVC.
4. PE 2708 or PVC service casings used to facilitate applicant installations are allowed to be installed on private property only. Refer to Gas Rule 16 for ownership requirements and responsibility to furnish materials. PE 2708 or PVC service casings shall be installed at or within the property line and terminate past the paved area with sufficient clearance to insert the gas service (carrier pipe), tie into the existing stub, and set the riser. Follow the requirements of GDS A-90 for the installation of stub services, plastic service completions, and riser installation details.
5. EFVs, couplings, fittings, curb valves, or other appurtenances shall not be installed within a PE 2708 or PVC service conduit. Install EFVs in accordance with the requirements of GDS A-90 and GDS A-93.3.
6. Service casing shall run in a straight line. Ensure that any sag or over bends are gradual.
7. Refer to [Table 2](#) on Page 6 for recommended casing sizes by gas carrier pipe size.
8. The maximum permissible length of a gas main casing is determined by the safe pulling loads. Refer to Chapter 6 of the *Horizontal Directional Drilling Manual* and GDS A-93.1 for specific guidance in determining allowable loads.
9. PE 2708 and PVC gas main sleeves and service conduits shall not branch or have elbows, reducers, or other inline fittings (except for electrofusion couplings) connected to it.
10. Gas main and service casings shall not contain any other facility other than the natural gas carrier pipe and associated locating wire.
11. When economically feasible, PE 2708 and PVC service casings may be accessed for branch installations. Follow the requirements of Item 2 on Page 8 for accessing service casings.

**Gas Service and Mains in Plastic Casing****A-75**

Publication Date: 03/23/2021 Effective Date: 03/23/2021 Rev. 2c

Limitations (continued)

**Table 2. Casing Selection Guide**

Gas Carrier Size (IPS) (Inches)	Recommended Casing Size (Inches)
2	4
	6
3	6
4	8
6	12
8	12

**Installation Requirements**

1. When installing the main or service, ensure that proper alignment and adequate support are provided where the pipe enters and leaves so that no strain will be placed on the carrier pipe.
2. Link seals and split end seals are not required on PE 2708 or PVC casings.
3. Follow the requirements of GDS A-93.1 for PE 2708 installation in a casing or bore hole.
4. PE 2708 and PVC casing materials shall be installed in backfill meeting the requirements specified in Exhibit B of Utility Standard S5453, "Joint Trench Configurations and Occupancy Guide."
5. All empty PE 2708 and PVC service conduits and gas main sleeves shall be capped before backfilling. Install plastic caps or redwood plugs in accordance with GDS A-81. Install EMS markers on both ends of the gas main sleeve or service conduit in accordance with GDS A-93.1.
6. If necessary, use a mandrel to prove that all service conduits and gas main sleeves are free and clear of dirt, rocks, and other debris before inserting a gas carrier pipe.
7. Where several service conduits have been installed in a joint trench, contact the other utilities involved to request that they seal the ends of their conduits adjacent to the building. A request should be made to each of the other utilities involved for their cooperation. Explain the reason for the seal, and the potential hazard of migrating gas.
8. Provide slack for the carrier pipe so that thermal contraction will not produce tension on the pipe or any fittings or connections.
9. PE 2708 service conduits and gas main sleeves shall be joined by the heat fusion methods prescribed in Table 7 of GDS A-93.1 or by electrofusion. All PE heat fusions and electrofusion connections shall be made in accordance with appropriate company heat fusion procedures. A current GDS D-34 qualification is not required to connect (join) casing materials.

**Gas Service and Mains in Plastic Casing****A-75**

Publication Date: 03/23/2021 Effective Date: 03/23/2021 Rev. 2c

## Installation Requirements (continued)

10. Install all PVC service casings in accordance with PG&E Numbered Document 062288.
11. PE 2708 and PVC gas main casings shall be installed to the greatest extent practical at an approximate 90° angle between the existing distribution main and the street or proposed paved area at the point of crossing.
12. PE 2708 and PVC gas main sleeves shall be installed with a minimum cover as specified in GDS A-93.1, unless it is installed in a joint trench crossing a street (paved) area where the cover requirement is determined by Exhibit B of Utility Standard S5453, "Joint Trench Configurations and Occupancy Guide." If a gas main sleeve is installed in a joint distribution trench, the gas main sleeve shall be in the same relative location in the distribution trench and shall have the same clearance from other structures that would be required for a direct burial installation.
13. PE 2708 and PVC service conduit shall be installed with a minimum cover as specified in GDS A-93.1, unless it is installed in a joint service trench where the cover requirement is determined by Exhibit B of Utility Standard S5453, "Joint Trench Configurations and Occupancy Guide." If a service conduit is installed in a joint service trench, the conduit shall be in the same relative location in the service trench and shall have the same clearance from other structures that would be required for a direct burial installation.
14. PE 2708 and PVC casings shall not be installed at a depth greater than the depths specified in Table 3 of GDS A-81.
15. All service conduits and gas main sleeves shall have a locating wire attached per the requirements of GDS A-90.2 or GDS A-90.3, as applicable. The locating wire may terminate either at the casing ends in an ETS or be connected to the locating wires on both ends of the casing.
16. PE 2708 and PVC service and PE 2708 gas main casings do not need to be leak tested.
17. PE 2708 and PVC service and PE 2708 gas main casings do not need to have vents installed except as noted in Item 18A below.
18. After the carrier (service) pipe is installed in the casing, the end of the casing nearest the house or structure being supplied shall be sealed so that any leaking gas cannot migrate through the casing to the building.
  - A. If the properly sized casing plug is available for PE 2708 casings, as listed in GDS B-90.2, use it for this purpose. Wrap the casing plug with Tac-Tape (Code 507036) or equivalent tape wrap. If a suitable plug is not available, a plug of duct seal at least 1" long should be used, followed by the Tac-Tape or equivalent. If the other end of the service conduit for the gas line terminates near another building or structure into which gas could migrate, take special precautions to vent the casing to a safe location.
  - B. PVC service conduit shall be sealed in accordance with Item 18A above.

**Gas Service and Mains in Plastic Casing****A-75**

Publication Date: 03/23/2021 Effective Date: 03/23/2021 Rev. 2c

## Installation Requirements (continued)

19. A 3" wide plastic marking tape with the words "Gas Line in Conduit" (Code 373371) shall be installed on PVC service conduit. The marking tape shall be spiral wrapped around the casing for its entire length and held in place with adhesive tape at 10' intervals. The marking tape shall be wrapped such that the horizontal distance between spirals does not exceed 36".
20. The owner of an empty casing shall furnish to PG&E, prior to acceptance of the casing, an as-built drawing (or service record) and a PG&E inspection record indicating that the casing was installed pursuant to this document.
21. Where a gas service or main is installed in a sleeve or conduit, document the information on the plat sheet and service order, as applicable. Refer to GDS A-93.1 for mapping and records management requirements.

**Maintenance and Operations**

1. Gas crews and other employees who could respond to a gas emergency should be made aware that some services and mains have been installed through plastic sleeves and conduits. They should be trained on how to recognize and to squeeze off pipe that has been so installed.
2. PE 2708 and PVC service conduits and gas main sleeves may be accessed by window cutting using Company-approved tools. Precautions shall be taken to avoid damaging the carrier pipe.
3. A gas service or main that is installed in a service conduit or gas main sleeve that has been squeezed off must be replaced. GDS A-93.1 provides specific replacement instructions.
4. Repair all damaged PVC service conduit in accordance with Numbered Document 058548.
5. If a broken service conduit or any other problems brought about by using a casing delays Company work, bill the applicant for lost time and associated repair or replacement costs before service completion.

**Target Audience**

Personnel who are involved in designing, procuring, or installing the equipment or material listed in this standard.

**Definitions**

**Casing** For the purposes of this gas design standard, a casing is also referred to as a sleeve or conduit. Casings are not pressurized and shall only be used to insert a natural gas carrier pipe.

**Gas Service and Mains in Plastic Casing****A-75**

Publication Date: 03/23/2021 Effective Date: 03/23/2021 Rev. 2c

**Compliance Requirement/Regulatory Commitment**

Code of Federal Regulations (CFR) Title 49, Transportation, Part 192—Transportation of Natural and Other Gas by Pipeline: Minimum Federal Safety Standards

*Records and Information Management:*

Information or records generated by this procedure must be managed in accordance with the Enterprise Records and Information (ERIM) Policy, Standards and Enterprise Records Retention Schedule (ERRS). Refer to GOV-7101S, "Enterprise Records and Information Management Standard," and related standards. Management of records includes, but is not limited to:

- Integrity
- Storage
- Retention and Disposition
- Classification and Protection

**References**

ASTM D638, "Standard Test Method for Tensile Properties of Plastics"

ASTM D1785-89, "Standard Specification for Polyvinyl Chloride (PVC) Plastic Pipe, Schedules 40, 80 and 120"

ASTM D2513 - 18a, "Standard Specification for Polyethylene (PE) Gas Pressure Pipe, Tubing, and Fittings"

ASTM F512, "Standard Specification for Smooth Wall Polyvinyl Chloride (PVC) Conduit and Fittings for Underground Installation"

Engineering Material Specification 64, "Specification for Polyvinyl Chloride (PVC) Conduits and Fittings"

Engineering Material Specification 2503, "Specifications for Furnishing and Delivery of Polyethylene (PE) Plastic Piping"

Gas Design Standard A-33.1, "Plastic Gas Lines on Bridge Structures"

Gas Design Standard A-36, "Design and Construction Requirements – Gas Lines and Related Facilities"

Gas Design Standard A-70, "Casings for Highway and Railroad Crossings"

Gas Design Standard A-81, "Plugs and Caps for Non-Pressurized Gas Pipelines"

Gas Design Standard A-90, "Plastic Main and Service Installation"

Gas Design Standard A-90.2, "Locating Wire Installation for Direct Burial Plastic Mains and Services"



**Gas Service and Mains in Plastic Casing****A-75****Publication Date:** 03/23/2021 **Effective Date:** 03/23/2021 **Rev.** 2c

## References (continued)

Gas Design Standard A-90.3, "Locating Wire Installation for Inserted Plastic Mains and Services"

Gas Design Standard A-93, "Polyethylene Pipe Specifications and Design Considerations"

Gas Design Standard A-93.1, "Plastic Gas Distribution System Construction and Maintenance"

Gas Design Standard A-93.3, "Excess Flow Valves"

Gas Design Standard B-90, "Plastic System Socket and Butt Fusion Fittings"

Gas Design Standard B-90.2, "Plastic System Accessories"

Gas Design Standard D-34, "Qualifications for Joining Plastic Pipe"

Gas Rule 15, "Gas Main Extensions"

Gas Rule 16, "Gas Service Extensions"

Numbered Document 058548, "Repairing Plastic Conduit and Fittings"

Numbered Document 062288, "Underground Conduits"

Utility Procedure TD-4170P-31, "Heat Iron Socket Fusion for Polyethylene Pipe"

Utility Procedure TD-4170P-33, "Heat Iron Saddle Fusion for Polyethylene Pipe (Mechanical Assist Tool)"

Utility Procedure TD-4170P-34, "Heat Iron Butt Fusion for Polyethylene Pipe (Mechanical)"

Utility Procedure TD-4170P-35, "Heat Iron Butt Fusion for Polyethylene Pipe (Hydraulic)"

Utility Procedure TD-4170P-40, "Electrofusion for Polyethylene Pipe (Coupling)"

Utility Procedure TD-4170P-41, "Electrofusion for Polyethylene Pipe (Saddle)"

Utility Standard S5453, "Joint Trench"

**Appendices**

NA

**Attachments**

NA

**Gas Service and Mains in Plastic Casing****A-75**

Publication Date: 03/23/2021 Effective Date: 03/23/2021 Rev. 2c

**Revision Notes**

Revision 2c has the following changes:

1. Updated reference to ASTM D2513 (now ASTM D2513 - 18a) in the following:
  - General Information 2
  - General Information Table 1, Footnote 5
  - References (Also, replaced title ASTM D2513, “Standard Specification for Thermoplastic Gas Pressure Pipe, Tubing, and Fittings,” [now ASTM D2513 - 18a, “Standard Specification for Polyethylene (PE) Gas Pressure Pipe, Tubing, and Fittings”).
2. Removed hyperlinks per current document management process.
3. In Compliance Requirement / Regulatory Commitment section, added boilerplate language on “Records and Information Management.”

Revision 2b (Publication Date: 05/20/2020, Effective Date: 08/20/2020) has the following changes:

1. Throughout the entire document, made the following changes:
  - Moved the contents from a PDF format into a Word format.
  - Updated “PE 2406” designation to “PE 2708.”
  - Removed reference to “plastic hotline.”
  - Changed “numbered document” to “gas design standard” or “GDS.”
  - Corrected internal references to pages, tables, items, and steps.
2. In the “General Information” section, updated the following:
  - Step 7: Changed second sentence to “Use company approved conduit for casing material when PE 2708 casing is not available.”
  - Step 8: Updated “gas transmission and distribution technical services” to “engineering personnel.”
3. In the “Application” section, the note after Step 3, removed “Note that the service casings may only be installed on private property.”
4. In the “Limitations” section, updated the following:
  - Step 3: Deleted first sentence. “Do not install PE 2406 or PVC casing materials in subsurface locations that are contaminated with hydrocarbons or other volatile organic compounds.”
  - Step 4: Changed “PE 2406 or PVC service casings shall only be installed on private property” to “PE 2708 or PVC service casings used to facilitate applicant installations are allowed to be installed on private property only.”
  - Step 6: Removed first sentence stating “The maximum permissible length of the service casing is 200 ft.”

**Gas Service and Mains in Plastic Casing****A-75****Publication Date:** 03/23/2021 **Effective Date:** 03/23/2021 **Rev.** 2c

## Revision Notes (continued)

5. In the “Installation Requirements” section, changed the following:

- Step 6: Updated “A mandrel shall be used ...” to “If necessary, use a mandrel ....”
- Step 9: Updated second sentence to read “All PE heat fusions and electrofusion connections shall be made in accordance with appropriate company heat fusion procedures.”
- Step 21: Removed reference to the obsolete Utility Standard D-S0457.

6. In the “References” section, changed the following:

- Removed reference for WP4170-06, “Polyethylene Heat Iron Butt Fusion.”
- Removed reference for WP4170-07, “Polyethylene Electrofusion Coupling and Saddle Connections.”
- Updated WP4170-04 to TD-4170P-31, “Heat Iron Socket Fusion for Polyethylene Pipe.”
- Updated WP4170-05 to TD-4170P-33 “Heat Iron Saddle Fusion for Polyethylene Pipe (Mechanical Assist Tool).”
- Added new reference for TD-4170P-34, “Heat Iron Butt Fusion for Polyethylene Pipe (Mechanical).”
- Added new reference for TD-4170P-35, “Heat Iron Butt Fusion for Polyethylene Pipe (Hydraulic).”
- Added new reference for TD-4170P-40, “Electrofusion for Polyethylene Pipe (Coupling).”
- Added new reference for TD-4170P-41, “Electrofusion for Polyethylene Pipe (Saddle).”

Revision 2a (Publication Date: 05/04/2009; Effective Date: none) has the following changes:

1. Added section records.

Revision 02 has the following changes:

1. Updated the “Acronyms” and “References” sections.
2. Added new Footnote 1 and rearranged the sequence of all footnotes in Table 1 on Page 3.
3. Expanded note following Item 11A(3) on Page 4.
4. This document is part of Change 61.

**Asset Type:** Distribution Mains, Distribution Services

**Function:** Design, Construction, Maintenance

**Document Contact:** [Gas Design Standard Responsibility List](#)



## GAS DESIGN STANDARD PLUGS AND CAPS FOR NON-PRESSURIZED GAS PIPELINES

A-81

Publication Date: 11/20/2019 Effective Date: 02/19/2020 Rev. 2

### Purpose and Scope

This gas design standard (GDS) illustrates, specifies dimensions, and provides code numbers for redwood plugs and plastic end (PE) caps for use on non-pressurized gas pipelines as described in Utility Procedure TD-9500P-16, "Abandonment of Underground Gas Facilities." It also provides the manufacturer's part numbers for PE caps.

### 1 General Information

- 1.1. Refer to Utility Procedure TD-9500P-16 for approved sealing methods of abandoned pipelines.
- 1.2. Refer to [Table 1](#) for redwood plug ([Figure 1](#)) dimensions and code numbers.
- 1.3. Refer to [Table 2](#) for PE cap ([Figure 2](#)) dimensions and code numbers. Contact the responsible gas engineer for cap sizes without code numbers, for pipe sizes not shown, or when the use of PE caps are at depths greater than those listed in [Table 3](#).
- 1.4. Do not use PE caps in aboveground locations or where the cap could be exposed to ultraviolet (UV) radiation.
- 1.5. Do not store PE caps uncovered or expose to UV radiation for extended periods of time.
- 1.6. If a PE cap is cracked or cut, discard it (do not use).
- 1.7. When using PE caps, backfill the first 12" above the cap with sand or other suitable material (refer to GDS A-03, "Gas Trench Design and Construction," and Engineering Material Specification EMS-4123, "Backfill Sand").
- 1.8. To ensure proper installation of PE caps (i.e., full depth of the cap is on the pipe), cut the pipe end squarely and place a mark on the pipe at each of the four quadrants a distance back from the end of the pipe equal to the depth of the cap. When the cap is fully installed, it should reach all four marks.
- 1.9. Only use PE caps listed in this standard (see [Table 2](#)).

# Plugs and Caps for Non-Pressurized Gas Pipelines

A-81

Publication Date: 11/20/2019 Effective Date: 02/19/2020 Rev. 2

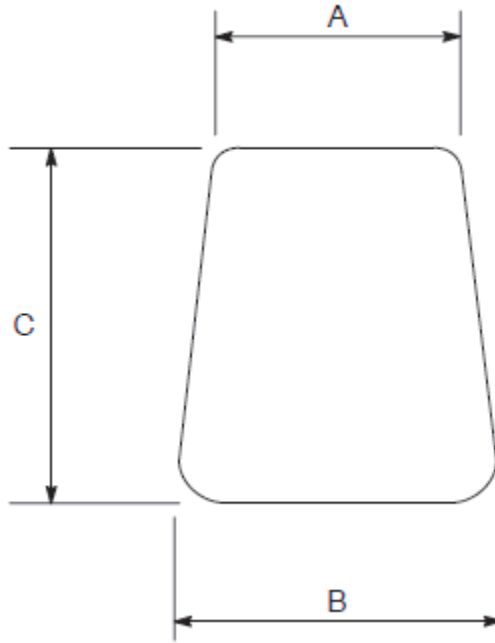


Figure 1. Redwood Plug

Table 1. Dimensions<sup>1</sup> and Code Numbers for Redwood Plugs

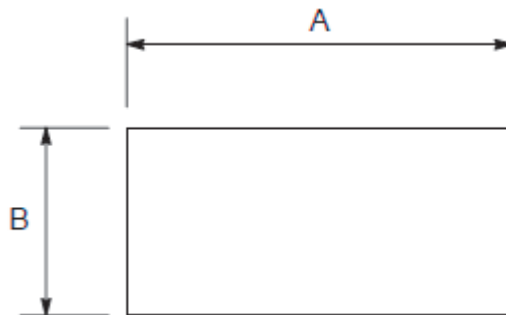
Nominal Pipe Size (NPS)	A	B	C	Code
3/4	1/4	1	4-3/8	204839
3/4-1-1/4	3/8	1-1/2	5-1/2	209036
1-1/4-1-1/2	1/2	2	5-1/2	209037
2	1-3/4	2-1/2	4	209038

1. All dimensions are in inches.

*cited in Cal. Rest. Ass'n v. City of Berkeley  
No. 21-16278am archived December 27, 2023*

**Plugs and Caps for Non-Pressurized Gas Pipelines****A-81**

Publication Date: 11/20/2019 Effective Date: 02/19/2020 Rev. 2

**Figure 2. PE Cap****Table 2. Dimensions<sup>1</sup>, Part Numbers, and Code Numbers for PE Caps**

NPS	A	B	Part Number	Code
2	2.378	1.096	RRC-2	021124
3	3.490	1.700	RRC-3	021125
4	4.500	1.725	RRC-4	021126
6	6.640	2.150	RRC-6	021127
8	8.670	2.310	RRC-8	021128
10	10.705	2.768	RRC-10	021130
12	12.679	2.820	RRC-12	021131
16	16.000	2.880	RRC-16	021132
18	18.000	2.845	RRC-18	021133
20	20.100	2.955	RRC-20	021144
22	22.000	2.986	RRC-22	—
24	24.000	2.995	RRC-24	021139
26	26.000	2.750	RRC-26	021140

1. All dimensions in inches.

**Plugs and Caps for Non-Pressurized Gas Pipelines****A-81****Publication Date: 11/20/2019 Effective Date: 02/19/2020 Rev. 2****Table 3. Approved PE Cap Usage by Pipe Size and Depth of Cover**

NPS <sup>1</sup>	Maximum Depth of Cover (to top of pipe) <sup>2</sup>		
	Horizontal Placement <sup>3</sup>	10° to 45° Placement <sup>4</sup>	45° to 90° Placement <sup>5</sup>
2	10	10	10
3	10	10	10
4	10	10	8
6	10	8	6
8	10	6	5
10	10	5	4
12	9	4	3
16	6	2	—
18	5	—	—
20	5	—	—
22	4	—	—
24	3	—	—
26	2	—	—

1. Measured in inches.
2. Measured in feet.
3. The axis of the pipeline is horizontal, angled up not more than 10°, or angled downward.
4. The axis of the pipeline is angled up more than 10°, but less than 45°.
5. The axis of the pipeline is angled more than 45°.

*cited in Cal. Rest. Ass'n v. City of Berkeley  
No. 21-16278am archived December 27, 2023*

**Plugs and Caps for Non-Pressurized Gas Pipelines****A-81****Publication Date:** 11/20/2019 **Effective Date:** 02/19/2020 **Rev. 2****Target Audience**

Personnel who use PE caps or redwood plugs for abandonment of gas facilities.

**Definitions**

NA

**Compliance Requirement / Regulatory Commitment**

NA

**References**

Engineering Material Specification EMS-4123, "Backfill Sand"

GDS A-03, "Gas Trench Design and Construction"

Utility Procedure TD-9500P-16, "Abandonment of Underground Gas Facilities"

**Appendices**

NA

**Attachments**

NA

**Revision Notes**

Revision 2 has the following changes:

1. Replaced Utility Operations (UO) Standard S4129, "Deactivation of Gas Facilities," with Utility Procedure TD-9500P-16, "Abandonment of Underground Gas Facilities."
2. Removed rows in [Table 1](#) featuring redwood plugs sizes 3" and bigger.
3. Simplified tables by adding footnotes and callouts.
4. Updated document formatting by converting to current template.

**Asset Type:** Storage, Compression & Processing, Measurement & Control, Transmission Pipe, Distribution Mains, Distribution Services, Customer Connected Equipment, CNG/LNG

**Function:** Engineering, Construction, Maintenance & Operations, and Emergency Administration

**Document Contact:** [Gas Design Standard Responsibility List](#)



cited in Cal. Rest. Ass'n v. City of Berkeley  
No. 21-16278am archived December 27, 2023



# GAS DESIGN STANDARD POLYETHYLENE GAS DISTRIBUTION SYSTEM DESIGN

A-90

Publication Date: 03/18/2020 Effective Date: 06/18/2020 Rev. 7

## Purpose and Scope

This gas design standard (GDS) provides design requirements for the Pacific Gas and Electric Company (PG&E or Company) polyethylene (PE) gas distribution system.

## 1 General Information

1.1. Connections within the PE system may be made with the following:

- A. Heat iron socket and butt fusion (reference GDS B-90, "Plastic System Socket and Butt Fusion Fittings").
- B. Heat iron saddle fusion (reference GDS B-90.1, "Plastic System Saddle Fittings").
- C. Electrofusion (reference GDS B-90.3, "Electrofusion Fittings and Tapping Tees").

**Note:** Molded butt fusion fittings are made to different specifications than PE pipe (fitting wall thickness may be greater than standard pipe wall thickness), and therefore are incompatible with mechanical fittings.

- D. Mechanical fittings (reference GDS B-91, "Transition Fittings for Polyethylene Pipe," and GDS B-91.1, "Polyethylene (PE) System Mechanical Fittings").

(1) Mechanical fittings are only allowed to be installed on the following PE materials:

- PE pipe
- Excess flow valves (EFV), including ½" molded EFVs
- Prefabricated gas service risers
- Prefabricated PE to steel transition fittings
- Electrofusion tapping tees with pipe pup
- PE valve with pipe pup

**Note:** Any connection to Aldyl-A pipe requires **only** mechanical or electrofusion fittings. Heat iron fusion is **not** allowed on Aldyl-A pipe.

**Polyethylene Gas Distribution System Design****A-90****Publication Date:** 03/18/2020 **Effective Date:** 06/18/2020 **Rev.** 7

- 1.2. Evaluate cathodic protection impacts of the design:
  - All isolated steel pipe, risers, valves, and fittings within a PE pipe system must be cathodically protected. Prefabricated risers, metallic components on plastic valves, tapping tees, and metallic bolts on plastic fittings do **not** need to be protected. Refer to Utility Manual TD-4180M, *Gas Transmission and Distribution Manual - Corrosion Control Volume*.
- 1.3. Ensure plastic mains or services are not subjected to temperatures greater than 120° F as described in GDS A-93, "Polyethylene Pipe Specifications and Design Considerations."
- 1.4. To deactivate a plastic service see GDS A-93.2, "Deactivation of Plastic Services."

**2 Materials**

Only pipeline components listed in the Company's GDSs, Engineering Material Specifications, Utility Bulletins, and Flash emails are allowed in construction of the gas system.

**2.1. Pipe****A. Main Pipe Sizing:**

- (1) Preferred pipe size is 2", 4", 6", or 8". PE pipe specifications and design are specified in GDS A-93.

**B. Service Pipe Sizing:**

- (1) New services must be 1" copper tubing size (CTS) or larger.
- (2) For fully replaced services, 1" CTS is the preferred minimum pipe size. When inserting or splitting, consider ½" pipe if adequate for service load and EFV sizing.
- (3) On applicant installed jobs, the Company may accept previously installed ½" CTS services and ½" CTS service stubs installed prior to May 1, 2010, if those services and stubs have the capacity to support the current customer loads, as approved by the local area engineer. See [Appendix 1](#) for the requirements that must be met to approve previously installed applicant installations.

**Polyethylene Gas Distribution System Design****A-90****Publication Date:** 03/18/2020 **Effective Date:** 06/18/2020 **Rev.** 7**2.2. Fittings**

- A. Heat iron fusion fittings are listed in GDS B-90 and GDS B-90.1.
- B. Electrofusion fittings are listed in GDS B-90.3.
- C. Approved PE-to-PE mechanical connections are listed in GDS B-90.1, GDS B-91, and GDS B-91.1.
- D. Make PE-to-steel, PE-to-copper, or PE-to-cast-iron transition joints using the approved transition fittings shown in:
  - (1) GDS B-54, "Compression Couplings"
  - (2) GDS B-91, "Transition Fittings for Polyethylene Pipe"
  - (3) GDS, B-91.1, "Polyethylene (PE) System Mechanical Fittings"
  - (4) GDS B-91.4, "Cast Iron to Steel Insulated Transition Couplings"
  - (5) GDS B-91.5, "Cast Iron to Polyethylene Transition Fittings"

**2.3. Risers**

- A. Prefabricated risers are listed in GDS A-91, "Prefabricated Risers."

**2.4. Valves**

- A. EFVs are listed in GDS A-93.3, "Plastic Excess Flow Valves."
- B. PE valves are listed in GDS F-90, "Polyethylene (PE) Valves."
- C. Do not install metallic valves in a PE system.

**2.5. PE Pipe Locating**

- A. For locating wire requirements see GDS A-90.2, "Locating Wire Installation for Direct Burial Plastic Mains and Services," and GDS A-90.3, "Locating Wire Installation for Inserted Plastic Mains and Services."

**Polyethylene Gas Distribution System Design****A-90**

Publication Date: 03/18/2020 Effective Date: 06/18/2020 Rev. 7

**3 PE Pipe System Design****3.1. PE Pipe Placement**

- A. See GDS A-04, "Cover and Clearance Requirements for Transmission Lines, Distribution Mains, and Service Lines," for depth of cover and clearance requirements.
- (1) Plastic pipe is susceptible to buckling and crushing at specified depths due to the effects of soil stresses. Plastic pipe may **not** be installed at a depth greater than 10', unless the installation is evaluated for fill-stress effects and is approved by the appropriate senior gas distribution engineer.
- B. The appropriate engineer should consider the following when determining whether to parallel or replace existing main for capacity jobs:
- Condition/Age of pipe
  - Leak history
  - Leak survey issues with having adjacent pipes
  - Additional relocation work during road reconstruction
  - Cost to transfer services

**3.2. Gas Service Placement**

- A. Gas service is normally installed in a straight line at a right angle to the main, traversing from the main to the meter.
- (1) Offsets, diagonal runs, and bends should be avoided wherever possible.
- (2) Where avoidable, service should **not** be installed under driveways or customer-paved areas.
- B. When an applicant changes the service-point location (flop lots), take one of the following actions:
- (1) For short-side service stubs:
- Cut off the service stub at the main per GDS A-93.2, and install a new service.
- (2) For long-side service stubs:
- IF the street is not yet paved,  
  
THEN cut off the service stub at the main per GDS A-93.2, and install a new service.

**Polyethylene Gas Distribution System Design****A-90****Publication Date:** 03/18/2020 **Effective Date:** 06/18/2020 **Rev.** 7

## 3.2 (continued)

- IF the street is paved and the walls of the new building are still opened,  
  
THEN use the existing service-point location and have the applicant re-plumb the houseline to the original service-point location.
  - IF the street is paved and the walls of the new building are closed,  
  
THEN consult the local area engineer to determine the change in service lay-out.
- C. The final grade level for a prefabricated riser must be at or below the red burial line indicated on the riser as described in GDS A-91.

## 3.3. Typical Subdivision Design for PE Pipe

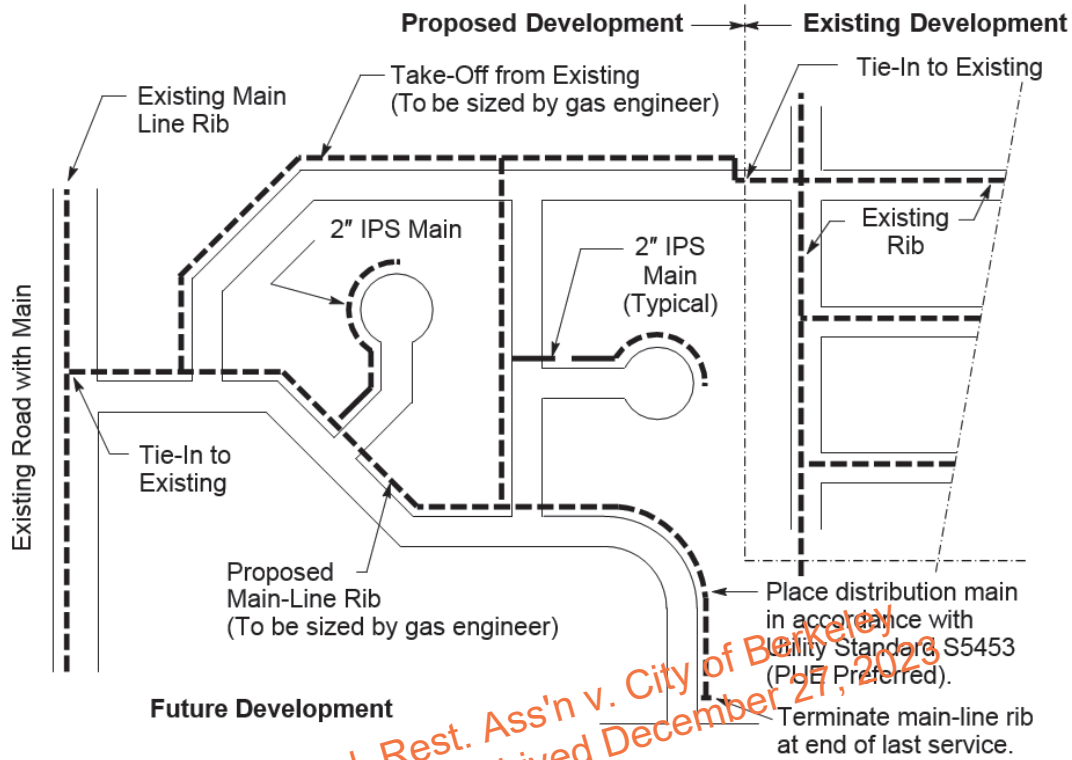
- A. [Figure 1](#) shows a typical subdivision design - infill and [Figure 2](#) shows a typical subdivision design - end of system growth.
- B. The appropriate senior gas distribution engineer must specify main-line rib sizes and tie-in locations.
- C. **Do not** terminate gas distribution facilities at the end of a development to clear paving or other improvements unless the applicant requests an extension to serve adjacent future development. Terminate these facilities approximately 5' past the last service, or to the next property line within the project area, unless approved by the appropriate senior gas distribution engineer.
- D. To make sharp turns or offsets (smaller than the minimum bend radius in [Table 2](#)), install full-opening heat fusion fittings per GDS B-90, or electrofusion fittings per GDS B-90.3.

**Polyethylene Gas Distribution System Design**

**A-90**

Publication Date: 03/18/2020 Effective Date: 06/18/2020 Rev. 7

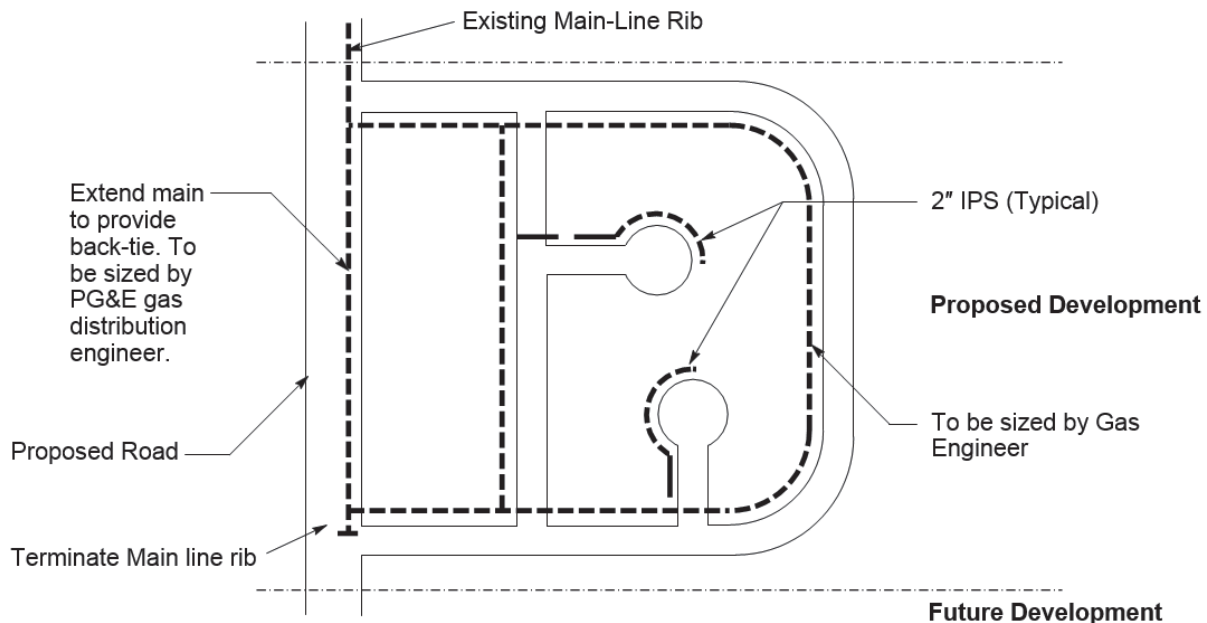
3.3 (continued)



*cited in Cal. Rest. Ass'n v. City of Berkeley*  
 No. 21-16278 am archived December 27, 2023

**Figure 1. Typical Subdivision Design – Infill**

- E. Place the gas facilities in the distribution trench per Utility Standard S5453, "Joint Trench." Placement in a public utility easement (PUE) is preferred.



**Figure 2. Typical Subdivision Design – End of System Growth**

**Polyethylene Gas Distribution System Design****A-90****Publication Date:** 03/18/2020 **Effective Date:** 06/18/2020 **Rev.** 7

## 3.3 (continued)

- F. A subdivision design for end of system growth is shown in [Figure 2](#). Extend the distribution main along the proposed road to provide a back-tie to the proposed development.

## 3.4. Branch Services

- A. Branch services must be designed and installed as outlined in GDS A-42, "Standard Branch Service Installation."
- B. Branching may be used to provide service to **no more** than two buildings. The meter installations must be located on the adjacent sides of the two buildings served. Where a branch-service installation is justified, a separate location for the gas meter and electric meter is permissible, if necessary.

## 3.5. Fault Line Crossings

- A. Avoid installing mains and services across fault lines whenever possible. Whenever it is necessary to install a main or service across a fault line, consider fault creep when designing the crossing and include appropriate precautions, such as the following:
- (1) Installing shut off valves on the main on either side of the crossing.
  - (2) Minimizing the use of fittings and bends in the vicinity of the crossing.
  - (3) Using a large-diameter plastic casing to absorb deflection caused by fault creep.
- B. Contact distribution integrity management program (DIMP) personnel for assistance in designing fault line crossings.

**4 Construction Methods**

## 4.1. PE Joining Methods

- A. The preferred joining methods for each size pipe is shown in Table 1.

**Table 1. PE Pipe - Joining Methods**

Pipe/Tubing Size or Connection Type	Preferred Joining Methods <sup>1</sup>	Alternate Joining Methods <sup>2</sup>
½" CTS–1¼" Iron Pipe Size (IPS)	Electrofusion, Socket Fusion	Mechanical
2" IPS	Electrofusion, Socket Fusion, Butt Fusion	Mechanical
3"–8" IPS	Butt Fusion	Electrofusion
Saddle	Electrofusion, Heat Iron Saddle	Bolt-On Saddle

1. Heat iron saddle, socket, and butt fusion are not permitted on Aldyl-A pipe.

2. Consider for repairs and tie-in connections.



**Polyethylene Gas Distribution System Design****A-90****Publication Date:** 03/18/2020 **Effective Date:** 06/18/2020 **Rev.** 7

## 4.1 (continued)

- B. A 2" mechanical stab type fitting may only be used for main or service PE pipeline repair, riser replacement, hot tie-in connections (a connection between a new or replaced section of pipeline and an existing pipeline already pressurized with natural gas), and main or service capping (end cap only).

## 4.2. Typical Direct-Burial Plastic Main and Service Installation

- A. Unless approved by engineering personnel **do not** install direct-buried plastic pipe under structures subject to settlement that could cause damage to the pipeline, such as: retaining structures, walls or footings, or adjacent to pile.
- B. **Do not** install direct-buried plastic pipe in unpaved areas where substantial wheel or equipment loading may damage the pipe, unless approved by the appropriate senior gas distribution engineer .
- C. A warning tape must be installed in direct-burial installations per GDS L-16, "Gas Pipeline Underground Warning Tape."

## 4.3. Directional Changes

- A. Changes in pipe direction must be made with elbows or tee fittings at street intersections (as illustrated in Attachment 1, "Illustration of a Direct Burial Main and Service Installation"). Roping may be used for directional changes at other locations, when necessary.
- B. Bends in roped PE pipe must be installed in the trench with a radius greater than the minimum recommended radius ([Table 2](#)). All bends must have a radius greater than: 20 times the pipe diameter for SDR 7 and 9, and 25 times the pipe diameter for SDR 10, 11, 11.5 and 13.5.
- C. There must be **no** fusion or mechanical joints within 3' of any bend.

**Table 2. PE Pipe Minimum Bend Radius**

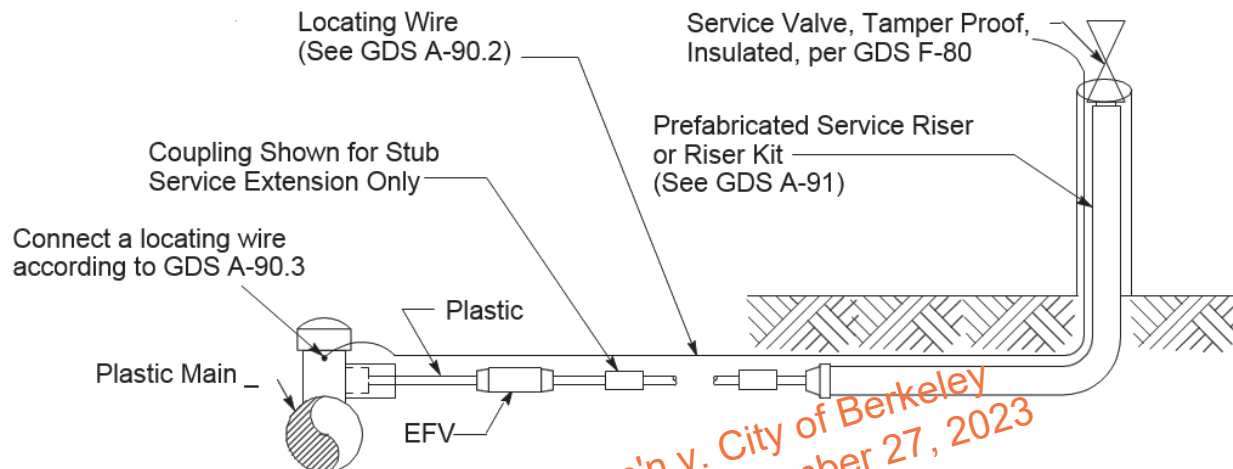
Nominal Pipe Size (Inches)	Minimum Bend Radius
½ CTS	15
1 CTS	28
1¼ IPS	42
2 IPS	60
3 IPS	84
4 IPS	114
6 IPS	168
8 IPS	216

**Polyethylene Gas Distribution System Design****A-90**

Publication Date: 03/18/2020 Effective Date: 06/18/2020 Rev. 7

## 4.3 (continued)

- D. Ensure that plastic pipe containing fusions or mechanical joints are installed in a straight alignment. Plastic pipe installations are in straight alignment if the bend radius of the pipe is greater than 150 times the pipe diameter.
- E. Figure 3 represents a typical lateral connection. See GDS B-90.1, and GDS B-90.3 for saddle fittings.



**Figure 3. Plastic Service Installation**

- F. For future lateral lines, install a minimum 3' stub with locating wire attached to an anode as described in GDS A-90.2.

## 4.4. Mechanical Insertion of PE Main and Service

- A. Refer to the documents below for information on specific casing applications and installations:
- (1) GDS A-75, "Gas Service and Mains in Plastic Casing," for the specific installation requirements for plastic pipe in a plastic casing.
  - (2) GDS A-33.1, "Plastic Gas Lines on Bridge Structures," for the specific installation requirements for plastic lines on bridge structures.
  - (3) GDS A-70, "Casings for Highway and Railroad Crossings," for casing size and other requirements for highway crossings.
- B. Do not transfer copper services to a new main or alter copper services (see Utility Standard TD-4801S, "Service Replacement Criteria").
- C. Plastic pipe is approved for inserting into existing mains and services. See GDS A-93.1, "Plastic Gas Distribution System Construction and Maintenance," for requirements.

**Polyethylene Gas Distribution System Design****A-90**

Publication Date: 03/18/2020 Effective Date: 06/18/2020 Rev. 7

## 4.4 (continued)

- D. Ensure that the minimum bend radius of PE pipe listed in [Table 2](#) is not exceeded during insertion into a casing.
- E. Provide for future laterals by installing stubs, or opening up the casing at appropriate locations (see [Figure 4](#), and [Figure 6](#)).
- F. Plug the space between the plastic and the casing pipe (see [Figure 5](#)) with casing plugs or cable protectors (see GDS A-70, and GDS A-73, "Casing Insulator and End Seals Selection Chart"), duct seal, or other suitable means not detrimental to PE pipe. See GDS A-75 for the plastic casing/sleeve sealing requirements.

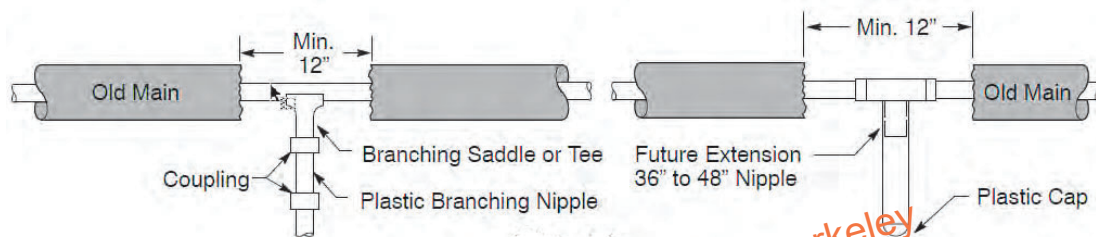


Figure 4. Laterals Off Plastic Main Insert

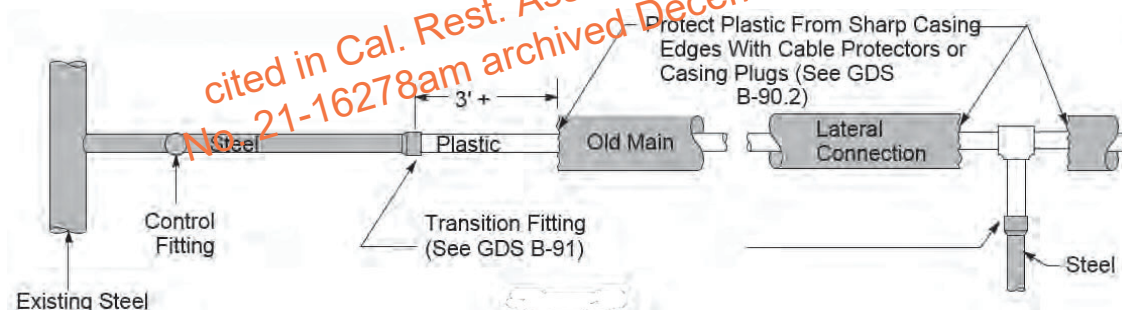


Figure 5. Tie-In to Steel

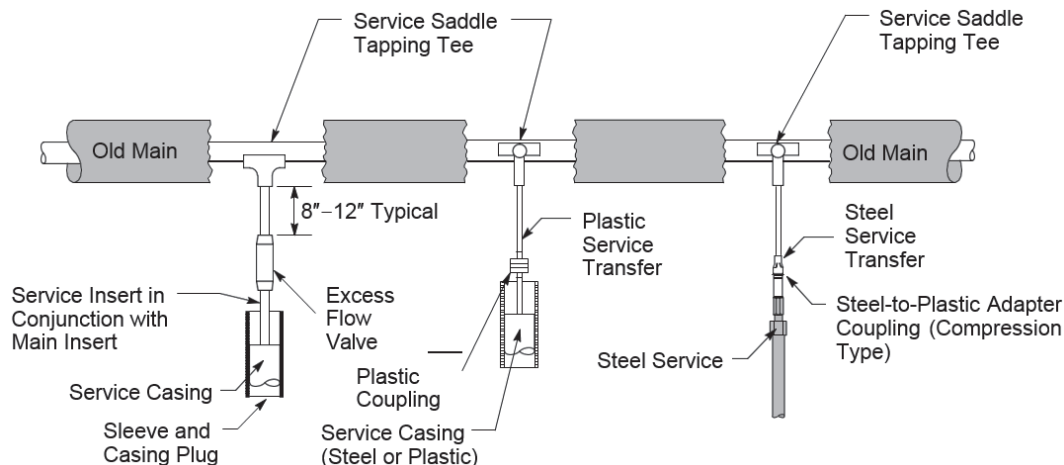


Figure 6. Service Connections Off Plastic Main Insert

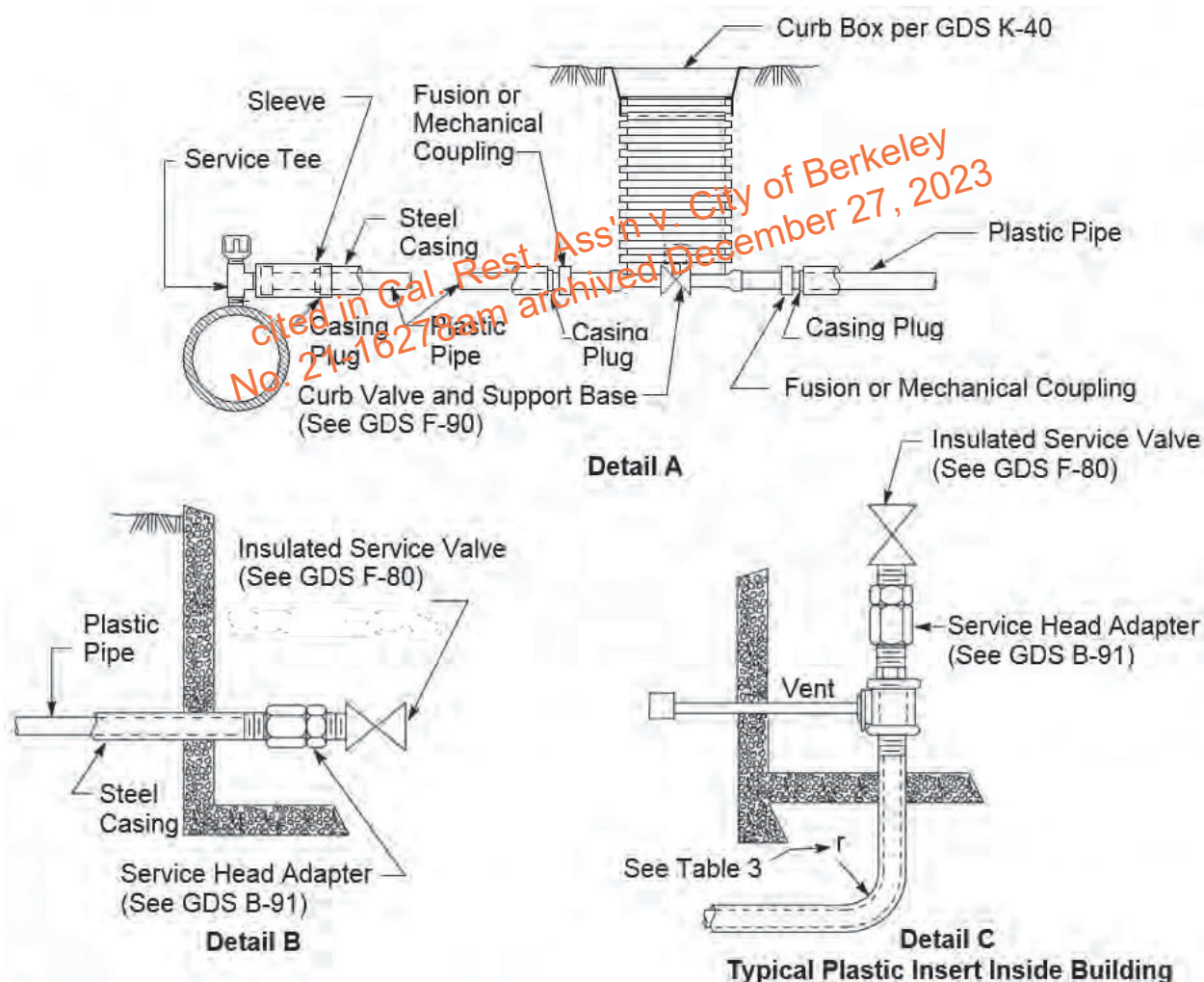
**Polyethylene Gas Distribution System Design****A-90**

Publication Date: 03/18/2020 Effective Date: 06/18/2020 Rev. 7

## 4.5. Riser Insertion

- A. Details for service head adapter installation are provided in GDS B-91.
- B. Whenever possible, the service riser must be relocated outside of the building (see GDS A-91). This section is intended for use on service renewals where a new service riser cannot be relocated outside of the building. See [Figure 7](#).
- C. See Detail B for riser going directly straight into a building.
- D. See Detail C for riser coming up from underneath a building.

**Note:** Detail C (below) is for above grade vent penetrations only. For subsurface vent penetrations consult local engineering.



**Figure 7. Typical Plastic Insert into Basement or Meter Box**

**Polyethylene Gas Distribution System Design****A-90**

Publication Date: 03/18/2020 Effective Date: 06/18/2020 Rev. 7

## 4.5 (continued)

- E. Where possible, the sleeve should bridge the gap between the service tee and the casing pipe. The plastic pipe must be supported by well compacted sand or fine soil.
- F. For typical scenarios of Detail C, the following method can be used to vent service casing:
- (1) Casing must be gas tight.
  - (2) Use minimum  $\frac{3}{8}$ " outside diameter (OD) stainless steel tubing or minimum  $\frac{1}{4}$ " nominal pipe size (NPS) steel pipe or approved flex hose as a vent pipe.
  - (3) Extend the vent to the outside of the building AND maintain the same clearances as regulator vent.
  - (4) Terminate the vent with insect-resistant fitting or screen.
  - (5) The vent line must be insulated where it passed through a wall, per GDS O-96, "Insulating Metal Gas Lines from Walls."
- G. **Do not** insert plastic pipe into a casing if the casing pipe radius is less than that shown in [Table 2](#).
- (1) If the radius is less than listed in [Table 2](#),  
THEN install a new riser with the proper bend radius.
- H. Install curb boxes so that external loads are not transmitted to the service. The valve box must **not** rest on the service pipe or casing.

**5 Records**

- 5.1. See GDS A-34, "Piping Design and Test Requirements," for leak test stamp requirements.
- 5.2. Retain records per the Record Retention Schedule.

**Target Audience**

The following personnel: gas planners, estimators, new business inspectors, gas distribution engineers, maintenance and construction, general construction, materials inspectors, and personnel involved in PE pipe connection training and qualification.

**Definitions**

NA

**Polyethylene Gas Distribution System Design****A-90****Publication Date:** 03/18/2020 **Effective Date:** 06/18/2020 **Rev.** 7**Compliance Requirement / Regulatory Commitment**

Code of Federal Regulations (CFR) Title 49, Transportation, Part 192—Transportation of Natural and Other Gas by Pipeline: Minimum Federal Safety Standards, Section 192.321, “Installation of plastic pipe”

**References**

ASTM F1973-08, Standard Specification for Factory Assembled Anodeless Risers and Transition Fittings in Polyethylene (PE) and Polyamide 11 (PA11) and Polyamide 12 (PA12) Fuel Gas Distribution Systems

Gas Design Standard A-04, “Cover and Clearance Requirements for Transmission Lines, Distribution Mains, and Service Lines”

Gas Design Standard A-15, “Code Numbers for Steel Pipe”

Gas Design Standard A-22, “Stainless Steel Tubing Specification”

Gas Design Standard A-33.1, “Plastic Gas Lines on Bridge Structures”

Gas Design Standard A-34, “Piping Design and Test Requirements”

Gas Design Standard A-42, “Standard Branch Service Installation”

Gas Design Standard A-44, “Service Connections to Cast Iron Main”

Gas Design Standard A-70, “Casings for Highway and Railroad Crossings”

Gas Design Standard A-73, “Casing Insulator and End Seals Selection Chart”

Gas Design Standard A-75, “Gas Service and Mains in Plastic Casing”

Gas Design Standard A-90, “Plastic Main and Service Installation”

Gas Design Standard A-90.2, “Locating Wire Installation for Direct Burial Plastic Mains and Services”

Gas Design Standard A-90.3, “Locating Wire Installation for Inserted Plastic Mains and Services”

Gas Design Standard A-91, “Prefabricated Risers”

Gas Design Standard A-93, “Polyethylene Pipe Specifications and Design Considerations”

Gas Design Standard A-93.1, “Plastic Gas Distribution System Construction and Maintenance”

Gas Design Standard A-93.2, “Deactivation of Plastic Services”

Gas Design Standard A-93.3, “Plastic Excess Flow Valves” Gas Design Standard B-14, “Standard Threaded Tee”

**Polyethylene Gas Distribution System Design****A-90****Publication Date:** 03/18/2020 **Effective Date:** 06/18/2020 **Rev.** 7

## References (continued)

Gas Design Standard B-15.1, "Threaded Bushing"

Gas Design Standard B-54, "Compression Couplings"

Gas Design Standard B-62, "Stainless Steel Tube Fittings"

Gas Design Standard B-90, "Plastic System Socket and Butt Fusion Fittings"

Gas Design Standard B-90.1, "Plastic System Saddle Fittings"

Gas Design Standard B-90.2, "Polyethylene (PE) System Accessories"

Gas Design Standard B-90.3, "Electrofusion Fittings and Tapping Tees"

Gas Design Standard B-91, "Transition Fittings for Polyethylene Pipe"

Gas Design Standard B-91.1, "Polyethylene (PE) System Mechanical Fittings"

Gas Design Standard B-91.4, "Cast Iron to Steel Insulated Transition Couplings"

Gas Design Standard B-91.5, "Cast Iron to Polyethylene Transition Fittings"

Gas Design Standard F-80, "Meter Valves"

Gas Design Standard F-90, "Polyethylene (PE) Valves"

Gas Design Standard J-15, "Gas Meter Locations"

Gas Design Standard J-16, "Gas Meter Room"

Gas Design Standard K-40, "Plastic Valve Box for 3/4" - 4" Valves"

Gas Design Standard L-16, "Gas Pipeline Underground Warning Tape"

Gas Design Standard O-96, "Insulating Metal Gas Lines from Walls"

Utility Manual TD-4180M, *Gas Transmission and Distribution Manual - Corrosion Control Volume*.

Utility Procedure TD-4110P-03-F01, "Leak Repair, Inspection, and Gas Quarterly Incident Report"

Utility Procedure TD-4634P-01, "Polyethylene Service Splitting"

Utility Standard GS I.S. 463-4, "Cover and Clearance Requirements for Transmission Lines, Mains and Service Lines"

Utility Standard S0470, "Design and Construction of Gas Distribution Facilities"

**Polyethylene Gas Distribution System Design****A-90****Publication Date:** 03/18/2020 **Effective Date:** 06/18/2020 **Rev. 7**

References (continued)

Utility Standard S5453, "Joint Trench"

Utility Standard TD-4801S, "Service Replacement Criteria"

Work Procedure WP4170-02, "Squeezing Polyethylene (PE) pipe"

**Appendices**[Appendix 1, "Application of New Installation and Design Requirements to Qualified Delayed Applicant-Installed Work"](#)**Attachments**

Attachment 1, "Illustration of a Direct Burial Main and Service Installation"

**Revision Notes**

Revision 7 has the following changes:

1. Incorporated content from Utility Bulletin TD-A-93.1B-001, "Mechanical Fittings Connections Use Clarification" to clarify what connections mechanical fittings can be used on.
2. Added guidance for fully replaced services, 1" ODS is the preferred minimum pipe size but to consider 1/2" pipe when inserting or splicing if adequate for service load and length.
3. Updated Table 1 to clarify preferred joining methods and alternate joining methods for PE pipe.
4. Clarified definition of hot tie-in for 2" stab fittings.
5. Added guidance on parallel main installations for capacity jobs.
6. Updated guidance on methods used to vent casings on risers.
7. Removed old plastic pipe stamp and referenced GDS A-34 for leak test stamp requirements.
8. Removed table for bend radius in riser casing, as Table 2 will be adequate table to use for that scenario.

**Asset Type:** Distribution Services**Function:** Design, Construction, and Maintenance**Document Contact:** [Gas Design Standard Responsibility List](#)



**Polyethylene Gas Distribution System Design****A-90****Publication Date:** 03/18/2020 **Effective Date:** 06/18/2020 **Rev.** 7**Appendix 1 – Application of New Installation and Design Requirements to Qualified Delayed Applicant-Installed Work**

Page 1 of 2

This appendix clarifies how to apply various new installation and design requirements to qualified delayed applicant-installed gas projects, where the gas distribution main backbone and service stubs were installed and inspected, but the service completions have not been completed for many months or years.

**Note:** This **does not** apply to any “at-risk” projects.

1. The Company has encountered delayed applicant-installed projects (e.g., subdivisions) where the gas distribution main backbone and service stubs were installed and inspected, but the service completions have not been completed for many months or years, and the system has not been pressurized, energized, and accepted by the Company. These projects must meet the following criteria:
  - Job designs were previously approved by the Company.
  - Contracts were executed by the applicant with the Company for the project.
  - Company has inspected the work to date on the project.
2. Current installation and design requirements must be applied when a delayed project is actually pressurized and placed in service.
3. This appendix addresses the following new requirements:
  - Pipe locating requirements
  - One-inch diameter services
  - 1000-foot maximum spacing between Electrolysis Test Stations (ETS)
  - Locating wire gauge requirements for plastic pipe installations
  - Pressure testing
4. Locating Requirements
  - A. Applicant installers are required to mark dead end gas mains, and gas service stubs as described in GDS A-90.2, and GDS A-90.3.
5. One-inch services
  - A. The Company will accept previously-installed ½” services, and ½” service stubs installed prior to May 1, 2010, if those services and stubs have the capacity to support the current customer loads.

**Polyethylene Gas Distribution System Design****A-90****Publication Date:** 03/18/2020 **Effective Date:** 06/18/2020 **Rev.** 7**Appendix 1 – Application of New Installation and Design Requirements to Qualified Delayed Applicant Installed Work**

Page 2 of 2

- B. The gas service stub must be at least 1" in diameter if any of the following conditions exists:
- Customer gas load conditions require a larger size gas service. For example, 1" EFVs and services are required for service lengths of 122' or longer, per GDS A-93.3. Note that GDS A-93.3 also directs that EFVs are not to be installed on stub completions
  - Branch services
  - Changed or new customer gas loads that exceed the capacity of the previously designed service
3. 1000' maximum spacing between ETS boxes
- Applicant installers are required to install ETS boxes every 1000'(or closer) in accordance with GDS A-90.2.
4. Locating wire gauge requirements for plastic pipe installations
- The Company will accept 14-gauge locating wire on existing plastic pipe service installations, installed prior to August 1, 2009, as long as the wire passes continuity tests. Applicant installers are not required to replace existing 14-gauge wire (that pass continuity tests) with 10-gauge on plastic services, and service stubs that have already been installed. However, all new plastic services and service stubs must be installed with 10-gauge wire in accordance with GDS A-90.2 and GDS A-90.3.
5. Pressure Test
- Main and stubs are required to be tested per GDS A-34.

cited in Cal. Rest. Ass'n v. City of Berkeley  
No. 21-16278am archived December 27, 2023



**GAS DESIGN STANDARD  
INSTALLING AND MAINTAINING A  
POLYETHYLENE (PE)  
GAS DISTRIBUTION SYSTEM**

A-93.1

Publication Date: 12/15/2021 Effective Date: 03/01/2022 Rev. 11

## Purpose and Scope

This gas design standard (GDS) provides requirements for installing and maintaining the Pacific Gas and Electric Company (PG&E or Company) polyethylene (PE) gas distribution system.

## 1 General Information

### 1.1 Joining PE

- A. For approved joining methods, approved materials, and qualification requirements, see [Appendix A](#).
- B. Standard heat iron fusions are **not** allowed on Aldyl-A material. Use **only** electrofusion or mechanical fittings with Aldyl-A material.
- C. Mechanical fittings are **not** allowed on molded butt fusion fittings such as 3-way tees, 90° elbows, 45° elbows, end caps, reducers, branch saddles, PE valves with molded ends, and tapping tees without pipe pups.
  - (1) **Exception:** ½ in. excess flow valves (EFVs) have molded ends but are made to pipe tolerances and are compatible with mechanical fittings.

### 1.2 Transitions from PE to Steel



#### CAUTION

If the transition joint is exposed to excessive heat when welding, the PE pipe could become damaged.

- A. Take precautions to protect the PE pipe at the point of transition when welding the steel end.
  - (1) Never shorten the steel portion of a transition fitting. Heat from welding can damage the PE pipe if the steel is cut.
  - (2) Protect the transition joint from excessive heat. Do **not** weld, thermite weld, or heat the body of the fitting; **only** butt welding of the steel end is permitted.
- B. During this welding, protect the PE part of the heat-fusion transition fitting from overheating by wrapping the midpoint of the steel part of the fitting with wet cloth to remove heat. Keep the cloth wet during the weld. After completing the weld, leave the wet cloth on the fitting until the steel pipe is cool enough to touch.

Printed copies of this document might be out of date. The Technical Information Library (TIL) has the current version.

## Installing and Maintaining a Polyethylene (PE) Gas Distribution System

A-93.1

Publication Date: 12/15/2021    Effective Date: 03/01/2022    Rev. 11

---

### 1.2 (continued)

- C. Adequately support the exposed PE pipe adjacent to the transition fitting with well-compacted sand or fine soil.

### 1.3. Prefabricated Risers

- A. For installation of pre-fabricated risers, see GDS A-91, "Prefabricated Risers."
- B. Repair any coating damage on risers in accordance with applicable coating/wrap standards.

### 1.4. Thermal Expansion

- A. When installing PE pipe, ensure that all plastic lines are slack before completing final tie-ins to allow for thermal expansion and contraction.

### 1.5. Marking New Service Installations

- A. All new or replaced services must have the curb (or street) marked indicating the location of the new or replaced service. This marking provides identification and location of the gas service pending the update of the service installation by mapping.
- B. IF the local municipalities or agencies have requirements that restrict marking the services,  
THEN note the restriction on the gas service record (GSR), per Utility Procedure TD-9500P-14, "Gas Service Records."

## 2 Construction Materials

### 2.1. Pipe

- A. Check the production date on the pipe.
  - (1) Yellow medium density polyethylene (MDPE) pipe more than 3 years old must be scrapped.

### 2.2. Fittings

- A. For approved fittings, see [Appendix A](#).
- B. Fittings and risers stored indoors, or stored outdoors **and** are covered, have an indefinite storage life. Only the PE portion of the riser outside of the riser casing requires a cover. The riser casing itself can be exposed to the elements.

---

Printed copies of this document might be out of date. The Technical Information Library (TIL) has the current version.

## Installing and Maintaining a Polyethylene (PE) Gas Distribution System

A-93.1

Publication Date: 12/15/2021 Effective Date: 03/01/2022 Rev. 11

### 3 Construction Methods

#### 3.1. PE Pipe Handling

- A. Carefully handle PE pipe to eliminate the possibility of damage during loading, unloading, and storage operations.
- (1) During transport, the pipe must be supported to minimize movement and must be located away from any source of heat, such as equipment or vehicle exhaust.
- a) Protect pipe against ropes or other securing devices.
- b) Do **not** use chains to secure the pipe.
- c) Do **not** place supplies or other equipment on top of the pipe.
- B. String coils of plastic pipe by hand or from a reel.
- (1) Coils of 4" diameter pipe and larger must be strung from an approved trailer designed for large-diameter, coiled PE pipe as described in GDS M-17.2, "Large Diameter PE Coil Pipe Trailers and Accessories."
- a) Coils must **not** be rolled over sharp objects OR pulled over rough surfaces.
- b) String straight lengths by lifting the pipe from the truck to the ground.
- c) The pipe must be protected from rocks or other abrasive material during this operation and must **not** be dropped from a height.



### WARNING

Considerable force may be required to field bend pipe. If pipe is released during bending the pipe may spring back forcibly causing bodily injury.

- (2) Observe proper safety precautions during field bending of pipe to avoid personnel injury.
- (3) Coiled PE pipe is confined with bands at intervals within the coils. As the pipe is uncoiled, take precautions to avoid kinking the pipe. Do **not** uncoil the pipe faster than the bands can be cut.

Printed copies of this document might be out of date. The Technical Information Library (TIL) has the current version.

## Installing and Maintaining a Polyethylene (PE) Gas Distribution System

A-93.1

Publication Date: 12/15/2021 Effective Date: 03/01/2022 Rev. 11

### 3.1 (continued)



#### CAUTION

Damage to the PE pipe can result from welding (weld or thermite weld) too close without protecting the pipe with a heat-resisting baffle or wet rags.

- C. To minimize the possibility of sparks or hot material coming into contact with the plastic pipe, do **not** perform welding on pipe immediately adjacent to plastic pipe.

### 3.2. Static Charge Build-Up in PE Pipe



#### WARNING

Discharge of static electricity can cause shocks or ignite a gas-air mixture.

- A. Control static charge build up in PE Pipe.
  - (1) Static-electric charges can build up on both the inside and outside surfaces of PE pipe. Localized, static-electric buildup occurs because PE pipe does not readily conduct electricity. See Utility Procedure WP4170-01, "Grounding Polyethylene (PE) Pipe to Control Static Electricity," for static-grounding procedures and requirements.

### 3.3. Depth of Cover for Main and Service

- A. For depth of cover requirements, see GDS A-04, "Cover and Clearance Requirements for Transmission Lines, Distribution Mains, and Service Lines."

### 3.4. PE Pipe Pressure Control (Squeeze-Off)

- A. Squeeze off PE pipe to extend or repair it. PE pipe is flexible and can be squeezed shut without damaging the pipe or reducing its pressure rating, provided the proper tools and procedures are used.
- B. For squeeze-off procedures, see Utility Procedure TD-4170P-02, "Squeezing Polyethylene (PE) Pipe."

Printed copies of this document might be out of date. The Technical Information Library (TIL) has the current version.

## Installing and Maintaining a Polyethylene (PE) Gas Distribution System

A-93.1

Publication Date: 12/15/2021 Effective Date: 03/01/2022 Rev. 11

### 3.5. Purging Plastic Mains and Services

- A. Remove static-electric charges by grounding the pipe whenever the pipe is purged. Refer to Utility Procedure WP4170-01.
- B. Purge plastic mains and services according to the provisions specified in GDS A-38, "Purging Gas Facilities," as applicable.
- C. If the service has an EFV, follow purging instruction in GDS A-93.3, "Excess Flow Valves."

### 3.6. Gauging Requirements/Continuity of Service

- A. It is Company policy to maintain uninterrupted service to customers during the construction, reconstruction, or maintenance of facilities as described in Distribution & Customer Service (DCS) Standard D-S0454, "Gas Mains, Maintaining Continuity of Service During Construction."

### 3.7. Direct Burial

- A. Warning tape must be installed in direct-burial installations per GDS L-16, "Gas Pipeline Underground Warning Tape."

### 3.8. Insertion of PE Main and Services in Casing

- A. Insert plastic pipe into an existing casing by performing the following steps:
  - (1) Clean the casing pipe.
  - (2) Ream the steel casings to protect the plastic insert from the sharp edges of the casing. Where necessary, the entire length of the casing pipe must be reamed.
  - (3) The leading edge of the plastic pipe or tubing must be sealed during insertion.
  - (4) Push the plastic pipe through the casing.
  - (5) Evaluate the first 5 feet (ft) of the plastic pipe for damage as it leaves the casing pipe.
  - (6) IF there is damage that is caused by the casing pipe,  
  
THEN remove the plastic pipe and repair the pipe as described in [Section 4](#).

Printed copies of this document might be out of date. The Technical Information Library (TIL) has the current version.



## Installing and Maintaining a Polyethylene (PE) Gas Distribution System

A-93.1

Publication Date: 12/15/2021 Effective Date: 03/01/2022 Rev. 11

## 3.8 (continued)

- B. Support exposed plastic at entry and exit points.
- (1) Plug the space between the plastic and the casing pipe (see GDS A-90, "Polyethylene Gas Distribution System Design") with casing plugs or cable protectors, duct seal, or other suitable means not detrimental to PE pipe.
  - (2) Support any non-cased plastic pipe with backfill.
- C. Plastic pipe is approved for double insertion into existing mains and services. This application is approved only if the following conditions are met:
- (1) It is not practical or economical to remove the previously inserted pipe.
  - (2) The installation is made per GDS A-75, "Gas Service and Mains in Plastic Casing," or GDS A-90, as applicable, particularly with respect to protecting and supporting the entry and exit points.
  - (3) The installation is mapped with both the casing size and casing material identified. For example, a 1/2 in. plastic service inserted into a 1 in. copper pipe that is inserted into a 2 in. steel line is mapped as shown in Figure 1.

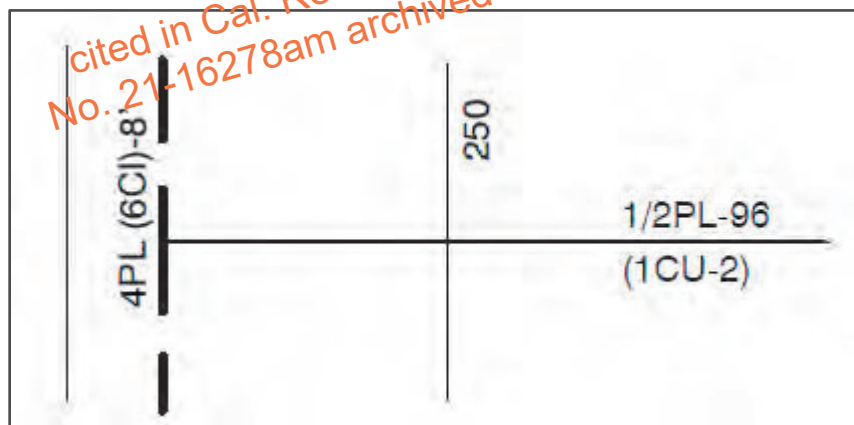


Figure 1. Mapping of a Double Insert

- D. Squeezing of the outer casing is **only** allowed in the event of an emergency. If the outer casing pipe is squeezed, the casing must be grounded. The PE gas-carrier pipe must be replaced after flow control is no longer needed.
- (1) IF the outer casing is metallic (e.g., steel or copper),  
  
THEN ground the casing using a ground cable that is grounded to wet earth.

Printed copies of this document might be out of date. The Technical Information Library (TIL) has the current version.

## Installing and Maintaining a Polyethylene (PE) Gas Distribution System

A-93.1

Publication Date: 12/15/2021 Effective Date: 03/01/2022 Rev. 11

### 3.8 (continued)

- (2) IF the outer casing is PE,  
  
THEN ground the squeezer and casing as if the casing were the carrier pipe in accordance with Utility Procedure WP4170-01.
- (3) IF the casing is polyvinylchloride (PVC) or cast iron,  
  
THEN remove the casing before squeezing the carrier pipe or tubing and ground the carrier pipe per Utility Procedure WP4170-01.
- (4) Take special precautions when accessing the carrier pipe (window cutting) to avoid damaging it.  
  
See Utility Procedure TD-4610P-01, "Accessing Polyethylene Pipe Within Steel Casing."
- (5) IF the pipe is damaged,  
  
THEN the carrier pipe must be repaired by replacing the damage section of the carrier pipe.

### 3.9. Boring or Splitting of PE Main and Service

- A. PE pipe may be pushed or pulled through a borehole as described in the following:
  - (1) Utility Manual TD-4135M, *Horizontal Directional Drilling Manual*
  - (2) GDS M-70.7, "Pneumatic Piercing Tools"
  - (3) Utility Procedure TD-4412P-05, "Excavation Procedures for Damage Prevention"
- B. During pipe pulling, constantly monitor the pulling force on the pipe and use a pulling head containing a weak-link or mechanical breakaway per GDS M-16.2, "Weak-link and Mechanical Breakaway Connectors Used in Polyethylene Pipe Installation."
- C. During horizontal directional drilling (HDD) operations, the equipment gauge pressure must **not** be used to determine pulling forces on the pipe.

Printed copies of this document might be out of date. The Technical Information Library (TIL) has the current version.

## Installing and Maintaining a Polyethylene (PE) Gas Distribution System

A-93.1

Publication Date: 12/15/2021    Effective Date: 03/01/2022    Rev. 11

---

### 3.9 (continued)



#### CAUTION

A weak-link or a mechanical break-away is critical to ensuring that PE pipe is installed without exceeding its design load.

- D. Examine the pipe as it leaves the hole to determine if the speed of the pipe is smooth and continuous. Any delay in the pipe pulling may indicate that the pipe has “hung up” and has possible damage.
- E. When installing PE using HDD, minimize variations in the bore to avoid adding drag when pulling back the pipe. Proper back-reaming and mudflow will help reduce the drag on PE when pulling back the pipe.
- F. PE services may be replaced per Utility Procedure TD-4634P-02, “Polyethylene Main and Service Line Splitting Using Winch Method.”
- G. IF pipelines are installed using technologies where a casing is required, including the following:
  - (1) HDD
  - (2) Steel pipe splitting (see GDS A-36.1, “Splitting Steel Pipe”)
  - (3) Cast-iron pipe bursting,

THEN it is acceptable to insert plastic pipe and tubing into a new plastic casing if the installation of the new plastic casing meets the following requirements:

- (1) All the current design requirements per GDS A-75 are satisfied.
- (2) The newly installed products are mapped correctly. For example, the bursting of a 4 in. cast-iron main for the placement of a 4 in. plastic main into a 6 in. plastic casing is mapped as follows: 4 - PL (6PL).

### 3.10. Riser Insert

- A. Before installing a service head adapter kit, inspect the PE tubing for damage (see Figure 2).
- B. For instructions on service head adapters, see Utility Procedure TD-4170P-52, “Mechanical Fitting Connections for Polyethylene Pipe (Threaded Compression Transitions).”

---

Printed copies of this document might be out of date. The Technical Information Library (TIL) has the current version.

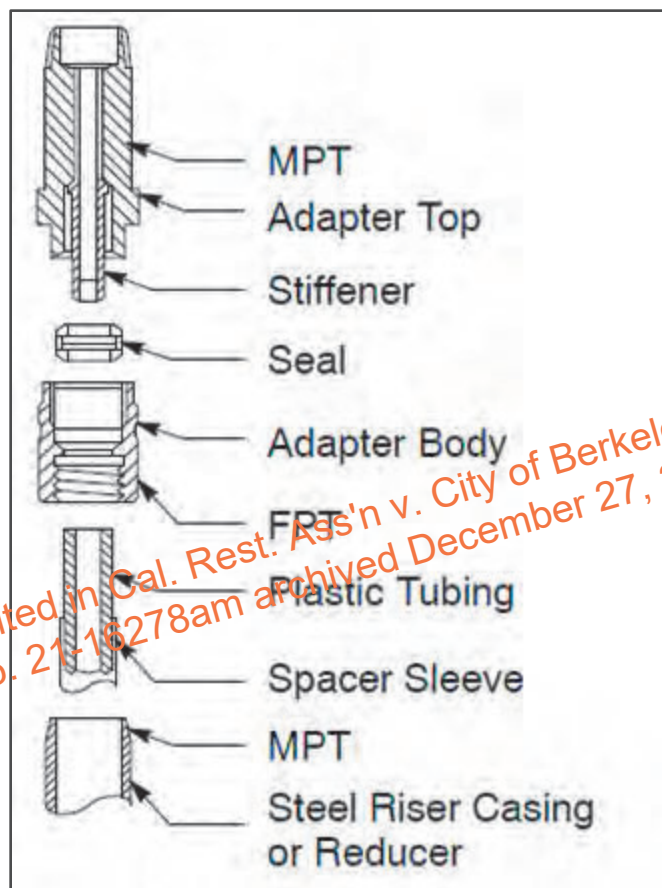
## Installing and Maintaining a Polyethylene (PE) Gas Distribution System

A-93.1

Publication Date: 12/15/2021 Effective Date: 03/01/2022 Rev. 11

## 3.10 (continued)

- C. Support the plastic pipe with well-compacted sand or fine soil.
- D. For locating wire requirements, see GDS A-90.2, "Locating Wire Installation for Plastic Mains and Services."



**Figure 2. Service Head Adapter**

## 3.11. Unsupported Pipe Spacing

- A. Determine the maximum unsupported length of pipe in an excavation using Table 1.

**Table 1. Maximum Unsupported Pipe Length**

Nominal Size (inches)	Maximum (feet)
2	4.9
4	6.5
6	7.9
8	9.1

Printed copies of this document might be out of date. The Technical Information Library (TIL) has the current version.

## Installing and Maintaining a Polyethylene (PE) Gas Distribution System

A-93.1

Publication Date: 12/15/2021 Effective Date: 03/01/2022 Rev. 11

### 3.12. Damage Inspection and Assessment

A. Carefully inspect PE pipe for debris, kinks, gouges, scratches, punctures, and other imperfections after each of the handling operations and before and during installation.

B. IF PE pipe has defects of damages exceeding 10% of the wall thickness of the pipe,

THEN the pipe must be rejected, and existing pipe replaced. Pipe wall thicknesses are listed in GDS A-93, "Polyethylene Pipe Specifications and Design Considerations."

(1) See Job Aid TD-A-93.1-JA01, "DGP-4 Pit Gauge for Polyethylene (PE) Pipe Wall Loss," on guidelines for measuring PE pipe loss.

## 4 PE Pipe Repairs

### 4.1. General Requirements

A. Make permanent repairs by replacing the damaged segment of plastic pipe.

B. Test segments of plastic pipe that are installed to replace damaged sections of mains and services per GDS A-34 "Piping Design and Test Requirements."

(1) Soap test mechanical fittings and couplings during leak testing.

(2) Soap test the repair and squeeze areas after the repair is complete.

C. Make permanent repairs to Nipak and Continental tapping tees with damaged caps by replacing the cap with the approved replacement caps listed in GDS B-90.2, "Polyethylene (PE) System Accessories."

D. A Performance Pipe 980 Quad Ring may be used to repair the Phillips Driscopipe old style orange resin tee (see Utility Procedure TD-4170P-57, Attachment 1, "Tapping Tee Identification and Component Replacement Kits"). The tee can be identified by the presence of a Quad Ring located at the top of the tapping tower.

E. Do not use mechanical leak repair clamps as a repair method for plastic pipe.

### 4.2. Repair and Test Requirements for PE Pipe Damaged by Dig-in or Other Causes

A. Visually inspect the plastic pipe upstream and downstream from the area of contact.

B. Replace only enough pipe to make a permanent repair.

Printed copies of this document might be out of date. The Technical Information Library (TIL) has the current version.

## Installing and Maintaining a Polyethylene (PE) Gas Distribution System

A-93.1

Publication Date: 12/15/2021 Effective Date: 03/01/2022 Rev. 11

---

### 4.2 (continued)

- C. Pressure leak test plastic pipe to be used for repair on site.
- D. Leak test the replaced section per GDS A-34.
- E. IF the casing is damaged (e.g., broken, bent, or crushed),  
  
THEN replace the plastic carrier pipe 2 ft upstream and downstream of the dig-in location.

### 4.3. Repairing a Service

- A. To determine if a service needs to be repaired or replaced, see Utility Standard TD-4801S, "Service Replacement Criteria."
- B. Pressure test service lines from the point of disconnection to the riser.
- C. IF, in a dig-in situation, it appears that the pipe or casing was pulled or moved between the point of impact and the main,  
  
THEN leak test per GDS A-34.

### 4.4. Plastic Service-Inserted Risers and Prefabricated Risers

- A. IF a PE service-inserted riser or prefabricated riser has been subjected to unusually high temperatures (such as being exposed to a house fire or meter fire),  
  
THEN immediately replace either the plastic insert or the entire riser.



### CAUTION

Pressure testing the service is **not** sufficient when a riser has been exposed to high temperatures. The plastic piping inside the riser could be damaged even though the pipe may hold during a leak test. When the service is used on a long-term basis, it could eventually rupture.

- B. IF a PE service-inserted riser or prefabricated riser casing has been damaged or corroded to where the riser is unable to support itself,  
  
THEN immediately replace either the plastic insert or the entire riser.
- C. Electric grounding or bonding wires must not be attached to any part of a PE service-inserted riser, prefabricated riser, or locating wire.

---

Printed copies of this document might be out of date. The Technical Information Library (TIL) has the current version.

## Installing and Maintaining a Polyethylene (PE) Gas Distribution System

A-93.1

Publication Date: 12/15/2021 Effective Date: 03/01/2022 Rev. 11

### 4.5. Dura-Line Pipe Connections

- A. Do not pressurize Dura-Line PolyPipe ½ in. copper tubing size (CTS), 1 in. CTS, or 1¼ in. iron pipe size (IPS) piping that was previously installed, but not yet tied-in.
- B. Whenever making a new connection to Dura-Line PolyPipe ½ in. CTS, 1 in. CTS, or 1¼ in. IPS piping, use only electrofusion or socket fusion. Mechanical fittings are not approved.
  - (1) If the Dura-Line PolyPipe ½ in. CTS, 1 in. CTS, or 1¼ in. IPS piping was capped with a Continental Constab Cap-n-Go coupling with a verified 100 pounds per square inch gauge (psig) air test, then the existing Cap-n-Go coupling is approved for connection.

### 4.6. Material Problem Report (MPR)

- A. A MPR is required for the following PE connection leaks:
  - (1) All fusion leaks, regardless of grade.
  - (2) All leaks found on Dura-Line PolyPipe ½ in. CTS, 1 in. CTS, or 1¼ in. IPS piping, regardless of connection type (fusion or mechanical).
  - (3) All Grade 1 leaks, regardless of connection type (fusion or mechanical).
  - (4) All connections (fusion or mechanical) that fail leak test.
- B. Submit a MPR by completing the following:
  - (1) Take a photo of the overall fusion and of the defect of the fusion prior to removal.
  - (2) Remove the leaking connection by cutting a minimum of 12 in. from both sides of the joint.
  - (3) Generate a MPR per Utility Procedure SCM-2106P-01, "Material Problem Report Procedure" and attach photos taken in the field.
  - (4) Tag and carefully package the fitting or connection along with the MPR number and leak notification number.
  - (5) Ship the package to the following address:

ATTN: MPR Shed  
3400 Crow Canyon Road  
San Ramon, CA 94583

Printed copies of this document might be out of date. The Technical Information Library (TIL) has the current version.

## Installing and Maintaining a Polyethylene (PE) Gas Distribution System

A-93.1

Publication Date: 12/15/2021 Effective Date: 03/01/2022 Rev. 11

### Target Audience

Gas distribution engineers, gas planners, estimators, new business inspectors, maintenance and construction (M&C) crews, materials inspectors, and personnel involved in PE pipe connection training and qualification.

### Definitions

NA

### Compliance Requirement / Regulatory Commitment

Code of Federal Regulations (CFR) Title 49, Transportation, Part 192—Transportation of Natural and other Gas by Pipeline: Minimum Federal Safety Standards, Section 192.321, “Installation of plastic pipe.”

Code of Federal Regulations (CFR) Title 49, Transportation, Part 192—Transportation of Natural and other Gas by Pipeline: Minimum Federal Safety Standards, Section 192.617, “Investigation of failures.”

Code of Federal Regulations (CFR) Title 49, Transportation, Part 192—Transportation of Natural and other Gas by Pipeline: Minimum Federal Safety Standards, Section 192.720, “Distribution systems: Leak repair.”

### Records and Information Management:

Information or records generated by this procedure must be managed in accordance with the Enterprise Records and Information (ERIM) Policy, Standards and Enterprise Records Retention Schedule (ERRS). Refer to GOV-7101S, “Enterprise Records and Information Management Standard,” and related standards. Management of records includes, but is not limited to:

- Integrity
- Storage
- Retention and Disposition
- Classification and Protection

Printed copies of this document might be out of date. The Technical Information Library (TIL) has the current version.



## Installing and Maintaining a Polyethylene (PE) Gas Distribution System

A-93.1

Publication Date: 12/15/2021 Effective Date: 03/01/2022 Rev. 11

---

### References

Distribution & Customer Service (DCS) Standard D-S0454, "Gas Mains, Maintaining Continuity of Service During Construction"

Engineering Material Specification EMS-4123, "Backfill Sand"

Gas Design Standard A-04, "Cover and Clearance Requirements for Transmission Lines, Distribution Mains, and Service Lines"

Gas Design Standard A-34, "Piping Design and Test Requirements"

Gas Design Standard A-36.1, "Splitting Steel Pipe"

Gas Design Standard A-38, "Purging Gas Facilities"

Gas Design Standard A-75, "Gas Service and Mains in Plastic Casing"

Gas Design Standard A-90, "Polyethylene Gas Distribution System Design"

Gas Design Standard A-90.2, "Locating Wire Installation for Plastic Mains and Services"

Gas Design Standard A-91, "Prefabricated Risers"

Gas Design Standard A-93, "Polyethylene Pipe Specifications and Design Considerations"

Gas Design Standard A-93.3, "Excess Flow Valves"

Gas Design Standard B-54, "Compression Couplings"

Gas Design Standard B-90, "Plastic System Socket and Butt Fusion Fittings"

Gas Design Standard B-90.1, "Plastic System Saddle Fittings")

Gas Design Standard B-90.2, "Polyethylene (PE) System Accessories"

Gas Design Standard B-90.3, "Electrofusion Fittings and Tapping Tees")

Gas Design Standard B-91, "Transition Fittings for Polyethylene Pipe"

Gas Design Standard B-91.1, "Polyethylene (PE) System Mechanical Fittings")

Gas Design Standard D-34, "Qualifications for Joining Polyethylene Pipe"

Gas Design Standard F-90, "Polyethylene (PE) Valves"

Gas Design Standard L-16, "Gas Pipeline Underground Warning Tape"

---

Printed copies of this document might be out of date. The Technical Information Library (TIL) has the current version.

## Installing and Maintaining a Polyethylene (PE) Gas Distribution System

A-93.1

Publication Date: 12/15/2021 Effective Date: 03/01/2022 Rev. 11

---

### References (continued)

Gas Design Standard M-16.2, "Weak-link and Mechanical Breakaway Connectors Used in Polyethylene Pipe Installation"

Gas Design Standard M-17.2, "Large Diameter PE Coil Pipe Trailers and Accessories"

Gas Design Standard M-70.7, "Pneumatic Piercing Tools"

Utility Manual TD-4135M, *Horizontal Directional Drilling Manual*

Utility Procedure SCM-2106P-01, "Material Problem Report Procedure"

Utility Procedure TD-4170P-31, "Heat Iron Socket Fusion for Polyethylene Pipe"

Utility Procedure TD-4170P-33, "Heat Iron Saddle Fusion for Polyethylene Pipe (Mechanical Assist Tool)"

Utility Procedure TD-4170P-34, "Heat Iron Butt Fusion for Polyethylene Pipe (Mechanical)"

Utility Procedure TD-4170P-35, "Heat Iron Butt Fusion for Polyethylene Pipe (Hydraulic)"

Utility Procedure TD-4170P-40, "Electrofusion for Polyethylene Pipe (Coupling)"

Utility Procedure TD-4170P-41, "Electrofusion for Polyethylene Pipe (Saddle)"

Utility Procedure TD-4170P-42, "Electrofusion for Polyethylene Pipe (Elbow)" Utility Procedure TD-4170P-50, "Mechanical Fitting Connections for Polyethylene Pipe (Stub Outlet)"

Utility Procedure TD-4170P-51, "Mechanical Fitting Connections for Polyethylene Pipe (Lyal Lycofit)"

Utility Procedure TD-4170P-52, "Mechanical Fitting Connections for Polyethylene Pipe (Threaded Compression Transitions)."

Utility Procedure TD-4170P-53, "Mechanical Fitting Connections for Polyethylene Pipe (Bolt-On Saddle)"

Utility Procedure TD-4170P-57, "Polyethylene Tapping Tee Repair Kits."

Utility Procedure TD-4412P-05, "Excavation Procedures for Damage Prevention"

Utility Procedure TD-4610P-01, "Accessing Polyethylene Pipe Within Steel Casing"

Utility Procedure TD-4634P-02, "Polyethylene Main and Service Line Splitting Using Winch Method"

---

Printed copies of this document might be out of date. The Technical Information Library (TIL) has the current version.

## Installing and Maintaining a Polyethylene (PE) Gas Distribution System

A-93.1

Publication Date: 12/15/2021 Effective Date: 03/01/2022 Rev. 11

---

### References (continued)

Utility Procedure TD-9500P-14, "Gas Service Record"

Utility Procedure WP4170-01, "Grounding Polyethylene (PE) Pipe to Control Static Electricity"

Utility Procedure TD-4170P-02, "Squeezing Polyethylene (PE) Pipe"

Utility Standard TD-4801S, "Service Replacement Criteria"

### Appendices

[Appendix A, "Polyethylene Joining Method and Approved Material References"](#)

### Attachments

Job Aid A-93.1-JA01, "DGP-4 Pit Gauge for Polyethylene (PE) Pipe Wall Loss"

### Revision Notes

Revision 11 has the following changes:

1. Removed references to sun shields in Section 1.
2. Updated squeeze off reference to current procedure Utility Procedure TD-4170P-02.
3. Removed backfill requirements in Section 3. Content has been incorporated in GDS A-03.
4. Updated splitting procedure reference to Utility Procedure TD-4634P-02 in Section 3.
5. Removed the requirement to rinse leak soap with clear water after performing soap test in Section 4.
6. Removed the following content that was moved to new GDS A-00, "Polyethylene Pipeline Components and Fittings Replacement Criteria":
  - Step 4.3 - Aldyl-A tee cap
  - Step 4.4 - Plexco Tee Caps
  - Step 4.8 - Kerotest Compression end valves
7. Added language to clarify the timeline for removal of plastic inserted and pre-fab risers exposed to excessive heat in Section 4.
8. Added requirements for connections to Dura-Line ½ in. CTS, 1 in. CTS, or 1¼ in. IPS piping in Section 4.

---

Printed copies of this document might be out of date. The Technical Information Library (TIL) has the current version.

**Installing and Maintaining a Polyethylene (PE)  
Gas Distribution System****A-93.1****Publication Date:** 12/15/2021 **Effective Date:** 03/01/2022 **Rev.** 11**Revision Notes** (continued)

9. Moved MPR requirement language to Section 4 and updated for clarity.
10. Removed qualification suspension and reinstatement information, because it is covered in GDS D-34 and Utility Procedure TD-4008P-03.
11. Updated reference documents to add:
  - Utility Procedure TD-4170P-02, "Squeezing Polyethylene (PE) Pipe"
  - Utility Procedure TD-4170P-42, "Electrofusion for Polyethylene Pipe (Elbow)"
  - Utility Procedure TD-4170P-51, "Mechanical Fitting Connections for Polyethylene Pipe (Lyal Lycofit)"
  - Utility Procedure TD-4634P-02, "Polyethylene Main and Service Line Splitting Using Winch Method"
12. Updated Appendix A to add:
  - Utility Procedure TD-4170P-42, "Electrofusion for Polyethylene Pipe (Elbow)"
  - Utility Procedure TD-4170P-51, "Mechanical Fitting Connections for Polyethylene Pipe (Lyal Lycofit)"

**Asset Type:** Distribution Mains, Distribution Services**Function:** Construction, Maintenance**Document Contact:** [Gas Design Standard Responsibility List](#)

---

Printed copies of this document might be out of date. The Technical Information Library (TIL) has the current version.

## Installing and Maintaining a Polyethylene (PE) Gas Distribution System

A-93.1

Publication Date: 12/15/2021 Effective Date: 03/01/2022 Rev. 11

### Appendix A, Polyethylene Joining Method and Approved Material References

#### Page 1 of 2

#### Joining Polyethylene (PE)

1. Only personnel qualified under GDS D-34, "Qualifications for Joining Polyethylene Pipe," can make connections to plastic gas distribution facilities.
2. Connections within the PE system must be made with the following:
  - Heat socket fusion and butt fusion (GDS B-90, "Plastic System Socket and Butt Fusion Fittings")
  - Heat saddle fusion (GDS B-90.1, "Plastic System Saddle Fittings")
  - Electrofusion (GDS B-90.3, "Electrofusion Fittings and Tapping Tees")
  - Mechanical connection (GDS B-91, "Transition Fittings for Polyethylene Pipe," and GDS B-91.1, "Polyethylene (PE) System Mechanical Fittings")
3. Qualified personnel must join PE pipe and fittings per approved heat-iron or electrofusion joining procedures:
  - Utility Procedure TD-4170P-31, "Heat Iron Socket Fusion for Polyethylene Pipe"
  - Utility Procedure TD-4170P-33, "Heat Iron Saddle Fusion for Polyethylene Pipe (Mechanical Assist Tool)"
  - Utility Procedure TD-4170P-34, "Heat Iron Butt Fusion for Polyethylene Pipe (Mechanical)"
  - Utility Procedure TD-4170P-35, "Heat Iron Butt Fusion for Polyethylene Pipe (Hydraulic)"
  - Utility Procedure TD-4170P-40, "Electrofusion for Polyethylene Pipe (Coupling)"
  - Utility Procedure TD-4170P-41, "Electrofusion for Polyethylene Pipe (Saddle)"
  - Utility Procedure TD-4170P-42, "Electrofusion for Polyethylene Pipe (Elbow)"

**OR** following approved mechanical fitting installation procedures:

  - Utility Procedure TD-4170P-50, "Mechanical Fitting Connections for Polyethylene Pipe (Stab Outlet)"

Printed copies of this document might be out of date. The Technical Information Library (TIL) has the current version.

**Installing and Maintaining a Polyethylene (PE)  
Gas Distribution System****A-93.1**

Publication Date: 12/15/2021 Effective Date: 03/01/2022 Rev. 11

**Appendix A, Polyethylene Joining Method and Approved Material References****Page 2 of 2**

3 (continued)

- Utility Procedure TD-4170P-51, "Mechanical Fitting Connections for Polyethylene Pipe (Lyal Lycofit)"
- Utility Procedure TD-4170P-52, "Mechanical Fitting Connections for Polyethylene Pipe (Threaded Compression Transitions)"
- Utility Procedure TD-4170P-53, "Mechanical Fitting Connections for Polyethylene Pipe (Bolt-On Saddle)"

**Construction Materials**

1. Heat Fusion Fittings are listed in GDS B-90 and GDS B-90.1.
2. Electrofusion Fittings are listed in GDS B-90.3.
3. PE-to-PE mechanical connections are listed in the following standards:
  - GDS B-90.1
  - GDS B-91
  - GDS B-91.1
4. Transition fittings are listed in the following standards:
  - GDS B-54, "Compression Couplings"
  - GDS B-91
  - GDS B-91.1
5. Excess flow valves are listed in GDS A-93.3.
6. Plastic valves are listed in GDS F-90, "Polyethylene (PE) Valves."
7. Prefabricated risers are listed in GDS A-91.

*cited in Cal. Rest. Ass'n v. City of Berkeley  
No. 21-16278am archived December 27, 2023*

cited in Cal. Rest. Ass'n v. City of Berkeley  
No. 21-16278am archived December 27, 2023



## GAS DESIGN STANDARD EXCESS FLOW VALVES

## A-93.3

Publication Date: 10/20/2021    Effective Date: 01/01/2022    Rev. 9c

### Purpose and Scope

This gas design standard (GDS) provides specifications and design information for selecting and installing polyethylene (PE) and steel excess flow valves (EFVs).

#### 1 General Information

- 1.1. EFVs are manufactured in accordance with American Society for Testing and Materials (ASTM International) F2138, "Standard Specification for Excess Flow Valves for Natural Gas Service," and ASTM F1802, "Standard Test Method for Performance Testing of Excess Flow Valves."
- 1.2. Only personnel qualified as described in GDS D-34, "Qualifications for Joining Polyethylene Pipe," may install a plastic EFV.
- 1.3. Only personnel qualified as described in applicable welding procedures may install a steel EFV.
- 1.4. See [Appendix C](#) for an EFV installation and replacement matrix.
- 1.5. Exceptions to the guidelines listed in this GDS may be granted by Standards Engineering.

#### 2 Applications for EFVs

- 2.1. Table 1 describes when EFVs must be installed on new, replaced, repaired, altered, and transferred service lines, except as noted in [Step 2.2](#).
  - A. In certain scenarios an EFV is required only when there is a new complete service line or new stub service. This does not include repairs, alterations, replacements, or stub completions. It is recommended to install an EFV on existing or replaced services or stub completions, where practical (e.g., installing an EFV would not require upsizing the existing service).

**Table 1. Required EFV Scenarios**

Service Type	Total Connected Load in Standard Cubic Feet per Hour (scfh)	
	0–1400	1401–5000
Single or branched service to single-family residence(s) <sup>1</sup>	EFV required	EFV required
Single or branched service to multifamily building(s) <sup>1</sup>	EFV required	EFV required for new service line <sup>2</sup>
Branched service to single-family residence and multifamily building <sup>1</sup>	EFV required	EFV required for new service line <sup>2</sup>
Single service to single commercial meter	EFV required	EFV required for new service line <sup>2</sup>
Any other service line (single or branched)	EFV required for new service line <sup>2</sup>	EFV required for new service line <sup>2</sup>

1. [Step 6.2. "Branched Service Lines"](#) describes appropriate EFV locations on branches.
2. [Step 2.1.A](#) provides an explanation on what is a new service line.

Printed copies of this document might be out of date. The Technical Information Library (TIL) has the current version.



**Excess Flow Valves****A-93.3**

Publication Date: 10/20/2021 Effective Date: 01/01/2022 Rev. 9c

2.2. An EFV is **not** required in the following situations:

A. The EFV is not required, per Table 2.

**Table 2. EFV Requirements – System Maximum Allowable Operating Pressure (MAOP)**

System MAOP	EFV Required
<10 psig	No
≥10 psig and ≤60 psig	Yes
>60 psig	No

B. The repair or alteration occurs more than 3' from the gas main, except for service stub completions.

C. The repair does not require the service line to be disconnected from the main (e.g., tee cap replacement).

2.3. If an EFV is **not** required, per [Step 2.1](#) and Step 2.2, AND **not** installed, a curb valve may be required per GDS A-43.2, "Curb Valves."

### 3 EFV Selection Guidelines

3.1. Determine if the service line requires the installation of an EFV, as described in [Section 2, "Applications for EFVs,"](#) of this GDS.

3.2. Determine the proposed or existing pipe size and material for the service.

3.3. Determine the load to be served by the EFV. If the EFV is to serve both the mother and branch of a branched service, combine the loads of both meter sets. If the meter badge rating is larger than 1,000 scfh, size the EFV based on meter capacity (not by total connected load). Use either option below:

- **Meter capacity:** Size the EFV based on the maximum continuous capacity of the meter listed in GDS J-10.1, "Diaphragm Meter Capacities," or GDS J-20, "Rotary Meter Capacity – At Standard and Elevated Delivery Pressures." Take metering pressure into account when determining the maximum continuous capacity.
- **Total connected load:** Use the total connected load of all customer appliances. Do not diversify the load. Include anticipated future load.

3.4. Determine the length of the service, as measured from the main to the meter location. If the EFV is to protect both the mother and branch of a branched service, the distance is measured to the farthest meter.

3.5. Determine the normal operating pressure (NOP) of the distribution system. For non-estimate work (such as emergency leak repair), gauge pressure can be used as NOP.

Printed copies of this document might be out of date. The Technical Information Library (TIL) has the current version.

**Excess Flow Valves****A-93.3**

Publication Date: 10/20/2021 Effective Date: 01/01/2022 Rev. 9c

- 3.6. Select the EFV based on the pipe size and material, load, service length, and design pressure as determined above.
- A. Refer to one of the following tables:
- (1) [Table 3](#), for plastic EFVs with plain ends
  - (2) [Table 4](#), for plastic EFVs with socket ends
  - (3) [Table 5](#), for EFVs incorporated into plastic electrofusion couplings
  - (4) [Table 7](#), for steel Honeywell Perfection EFVs
- B. Where more than one EFV would be suitable for the service, it is recommended to choose the EFV with the highest capacity. There is no minimum load for an EFV to function properly.
- 3.7. For service lines with more than one size of pipe, select one pipe size (to match the proposed EFV size) for the purpose of EFV selection. Convert the length of pipe of any other size to an equivalent length of pipe of the selected size. See [Appendix B](#).
- 3.8. When sizing an EFV for an existing service line that will not be replaced (i.e., transferred services, repairs, and high-pressure regulator rebuilds) and has no EFV installed, it is acceptable for the service length to exceed the maximum length for the EFV shown in [Table 3](#), [Table 4](#), [Table 5](#), or [Table 7](#). Choose the EFV that provides the greatest length of protection while providing adequate capacity for the load. In the Notes section of the gas service record, note that "the service line is partially protected."
- 3.9. EFV combi valves (curb valve and EFV combined) listed in [Table 6](#) may be used where EFVs and curb valves would be located close to each other or where space constraints prevent them from being installed separately.
- 3.10. Refer to [Appendix A](#) for data on pressure drop across EFVs.

**4 Plastic EFV Specifications and Material Codes**

- 4.1. Specifications and material codes for EFV with plain ends are listed in [Table 3](#).

**Excess Flow Valves****A-93.3**

Publication Date: 10/20/2021 Effective Date: 01/01/2022 Rev. 9c

**Table 3. EFV Specifications and Material Codes for Plastic Plain End EFVs**

Size (in)	EFV Flow Series	NOP $\geq$ 10 psig <sup>1</sup>		NOP $\geq$ 24 psig <sup>2</sup>		Material Code	Part Numbers	
		Maximum Total Connected Load (scfh)	Maximum Service Length (ft)	Maximum Total Connected Load (scfh)	Maximum Service Length (ft)		Honeywell Perfection <sup>3</sup>	GasBreaker Model 51
½ copper tubing size (CTS)	400	385	122	395	251	M022896	51910202PGE	—
	600	595	45	595	107	M022929	51910210PGE	—
	800	700	28	790	66	M022916	51910222PGE	—
1 CTS	800	700	1000	790	2355	M022917	51523PGE	—
	1100	990	261	1085	1000	M022918	51758013PGE	20382GB
	1800	1620	122	1775	437	M022921	51258PGE	20383GB
1¼ iron pipe size (IPS)	2600	2340	560	2340	1697	M022923	51758025PGE	20394GB
	5500	4912	125	5000	390	M026962	—	20395GB
2 IPS	5500 <sup>4</sup>	5000	1899	5000	3149	M022928	51950106PGE	20397GB

1. The values in this column are based on a 10 psig design pressure.
  2. The values in this column are based on a 20 psig design pressure.
  3. Honeywell Perfection EFVs whose part numbers end in PGE are special order for PG&E. The only difference is they come with two metal tags instead of one.
  4. 2-inch IPS 5500 EFVs can be used with two reducers and installed on 1¼ IPS service lines. Appendix B provides examples to perform equivalent length calculations, where the maximum service length for NOP  $\geq$  10 psig is 507 ft and the maximum service length for NOP  $\geq$  24 psig is 508 ft.
- 4.2. Specifications and material codes for EFVs with socket ends are listed in [Table 4](#).

Printed copies of this document might be out of date. The Technical Information Library (TIL) has the current version.

**Excess Flow Valves****A-93.3**

Publication Date: 10/20/2021 Effective Date: 01/01/2022 Rev. 9c

**Table 4. EFV Specifications and Material Codes for Plastic Socket End EFVs**

Size (in)	EFV Flow Series	NOP ≥ 10 psig <sup>1</sup>		NOP ≥ 24 psig <sup>2</sup>		Material Code	Manufacturer	Part Numbers
		Maximum Total Connected Load (scfh)	Maximum Service Length (ft)	Maximum Total Connected Load (scfh)	Maximum Service Length (ft)			
½ CTS	400	357	177	400	341	M025078	Lyall	EFV100-000002-001
	400	385	122	395	251	M020947	Honeywell Perfection	51716
	775	692	30	775	72	M025079	Lyall	EFV100-000011-001
	800	700	28	790	66	M020949	Honeywell Perfection	51713
1 CTS	775	692	1419	775	2916	M025080	Lyall	EFVEC-BB3DT00-004
	800	700	1000	790	2355	M020951	Honeywell Perfection	51715XMD
	1200	1072	523	1200	1196	M025081	Lyall	EFVED-BB3DT00-004
	1800	1584	104	1800	385	M025082	Lyall	EFVEE-BB3DT12-004
	1800	1620	122	1775	437	M020954	Honeywell Perfection	51745XMD
1¼ IPS	2600	2322	952	2600	1897	M025084	Lyall	EFV300-000002-003
2 IPS	5500 <sup>3</sup>	4818	1495	5000	2855	M025086	Lyall	EFV300-000008-002

1. The values in this column are based on a 10 psig design pressure.
2. The values in this column are based on a 20 psig design pressure.
3. 2-inch IPS 5500 EFVs can be used with two reducers and installed on 1¼ IPS service lines. Appendix B provides examples to perform equivalent length calculations, where the maximum service length for NOP ≥ 10 psig is 239 ft and the maximum service length for NOP ≥ 24 psig is 456 ft.

4.3. Specifications and material codes for electrofusion couplings with an incorporated EFV are listed in [Table 5](#).

Printed copies of this document might be out of date. The Technical Information Library (TIL) has the current version.

**Excess Flow Valves****A-93.3**

Publication Date: 10/20/2021 Effective Date: 01/01/2022 Rev. 9c

**Table 5. EFV Specifications and Material Codes for Plastic Electrofusion Couplings With Incorporated EFV**

Size (in)	EFV Flow Series	NOP ≥ 10 psig <sup>1</sup>		NOP ≥ 24 psig <sup>2</sup>		Material Code	Part Numbers
		Maximum Total Connected Load (scfh)	Maximum Service Length (ft)	Maximum Total Connected Load (scfh)	Maximum Service Length (ft)		
1 CTS x ½ CTS	500	510	119	571	225	M026396	128240
1 CTS	680	696	2565	779	4873	M026397	128238
1¼ IPS	1700	1789	3101	2003	5854	M026398	128241
2 IPS	4800	4960	2913	5554	5520	M026399	128257

1. The values in this column are based on a 10 psig design pressure.
2. The values in this column are based on a 20 psig design pressure.

4.4. Honeywell Perfection combination EFV and curb valve comes with plain pipe pups. Material codes and specifications are listed in Table 6.

**Table 6. EFV Specifications and Material Codes for Plastic EFV / Curb Valve Combos With Plain Ends**

Size (in)	EFV Flow Series	NOP ≥ 10 psig <sup>1</sup>		NOP ≥ 24 psig <sup>2</sup>		Material Code	Part Numbers
		Maximum Total Connected Load (scfh)	Maximum Service Length (ft)	Maximum Total Connected Load (scfh)	Maximum Service Length (ft)		
½ CTS	400	385	122	395	251	M038509	45130140PGE
	600	595	45	595	107	M038510	45130141PGE
	800	700	28	790	66	M038513	45130142PGE
1 CTS	800	700	1000	790	2355	M038514	45130145PGE
	1100	990	261	1085	1000	M038529	45130146PGE
	1800	1620	122	1775	437	M038530	45130147PGE

1. The values in this column are based on a 10 psig design pressure.
2. The values in this column are based on a 20 psig design pressure.

4.5. Extra metal tags may be purchased using material code M020957.

**5 Steel EFV Specifications and Material Codes**

- 5.1. Steel service lines requiring an EFV are to be replaced with plastic, if practical, per Utility Standard TD-4801S, "Service Replacement Criteria." If a plastic replacement is not practical, install a steel EFV per [Table 7](#).
- 5.2. When welded into a steel service, a steel EFV provides electrical continuity for cathodic protection.
- 5.3. Steel EFVs are intended for ¾" steel service lines and have the following specifications:

Printed copies of this document might be out of date. The Technical Information Library (TIL) has the current version.

**Excess Flow Valves****A-93.3****Publication Date:** 10/20/2021 **Effective Date:** 01/01/2022 Rev. 9c

- A. Series 800 and 1100 steel EFVs are contained in a stick of 3/4" NPS Schedule 40 pipe with ends beveled for welding.
- B. Series 1800 steel EFV is contained in a stick of 1" NPS Schedule 40 pipe with a 1" x 3/4" reducer at each end.
- C. Pipe is Grade B and conforms to ASTM A53, "Standard Specification for Pipe, Steel, Black and Hot-Dipped, Zinc-Coated, Welded and Seamless."

5.4. Steel EFV specifications and material codes are listed in [Table 7](#).

**Table 7. EFV Specifications and Material Codes for Steel Weld End EFVs**

Size (in.)	EFV Flow Series	NOP ≥ 10 psig <sup>1</sup>		NOP ≥ 24 psig <sup>2</sup>		Material Code	Part Numbers
		Maximum Total Connected Load (scfh)	Maximum Service Length (ft)	Maximum Total Connected Load (scfh)	Maximum Service Length (ft)		
3/4 NPS	800	665	329	790	787	M032155	51733011
	1100	915	92	1085	336	M032168	51733012
	1800	1495	51	1775	151	M032169	51733013

1. The values in this column are based on a 10 psig design pressure.

2. The values in this column are based on a 20 psig design pressure.

**6 EFV Installation Locations Guidelines****6.1. New or Fully Replaced Service Lines**

- A. For new or fully replaced services, install the EFV as close as practical to the gas main.
- B. For services fed by farm tap regulator sets, install the plastic EFV approximately 3' from the steel-to-plastic transition fitting downstream of the farm tap regulator set.
  - (1) Include an electronic marker system (EMS) marker with the EFV to allow for future locating in the event the EFV must be replaced or removed.
  - (2) See GDS H-10, "High-Pressure Regulator-Type Stations and Farm Tap Regulator Sets."

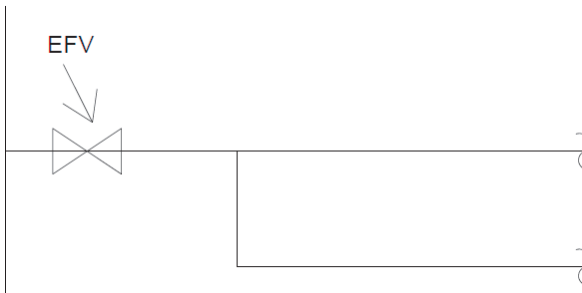
**6.2. Branched Service Lines**

- A. For a new or fully replaced mother and branch service installation:
  - (1) Install one EFV on the mother service as close as practical to the gas main, having designed the EFV with adequate capacity and protected length for both mother and branch. See Figure 1.

Printed copies of this document might be out of date. The Technical Information Library (TIL) has the current version.

**Excess Flow Valves****A-93.3**

Publication Date: 10/20/2021 Effective Date: 01/01/2022 Rev. 9c

**Figure 1: Branched Service Line**

- B. For a new branch being added to an existing single service line that has an existing EFV:
- (1) If existing EFV on mother service protects entire length of new branch service and has adequate capacity for both meter sets, leave the existing EFV in place.
  - (2) If existing EFV on mother service does **not** protect entire length of new branch service or has inadequate capacity, select a new EFV with adequate capacity to protect both mother and branch, and replace the existing EFV.
    - a) If this cannot be achieved, run a new single service instead of a branch.
- C. For a new branch being added to an existing single service line that does not currently have an EFV:
- (1) Select a new EFV with adequate capacity to protect both mother and branch, and install EFV at the main or the nearest non-paved point.
    - a) If this cannot be achieved, run a new single service instead of a branch.

---

 Printed copies of this document might be out of date. The Technical Information Library (TIL) has the current version.

**Excess Flow Valves****A-93.3**

Publication Date: 10/20/2021 Effective Date: 01/01/2022 Rev. 9c

## 6.3. Stub Completions

- A. For an existing stub on a single service or a branched service where neither side has been completed:
- (1) When completing an existing stub that is missing an EFV, install the EFV at the nearest non-paved point to the gas main or at the main. See Figure 2 and Figure 3 for EFV locations on common installation scenarios.

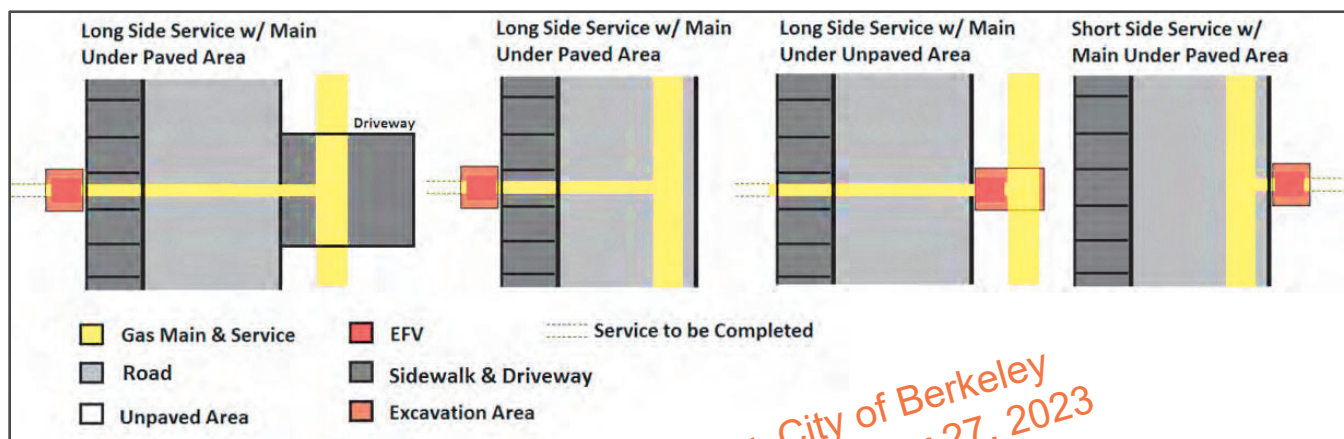


Figure 2. EFV Locations on Common Installation Scenarios

- B. For an existing stub that is part of a branched service line where the other side has already been completed:
- (1) If there is **no** EFV upstream of the branching point, install an EFV at the non-paved point nearest to the branching point.
  - (2) If there is an existing EFV upstream of the branching point, ensure it will protect the entire length of the completed service and it has adequate capacity for both meter sets.
  - (3) See [Figure 3](#) for EFV locations on common branch installation scenarios.



## Excess Flow Valves

A-93.3

Publication Date: 10/20/2021 Effective Date: 01/01/2022 Rev. 9c

## 6.3 (continued)

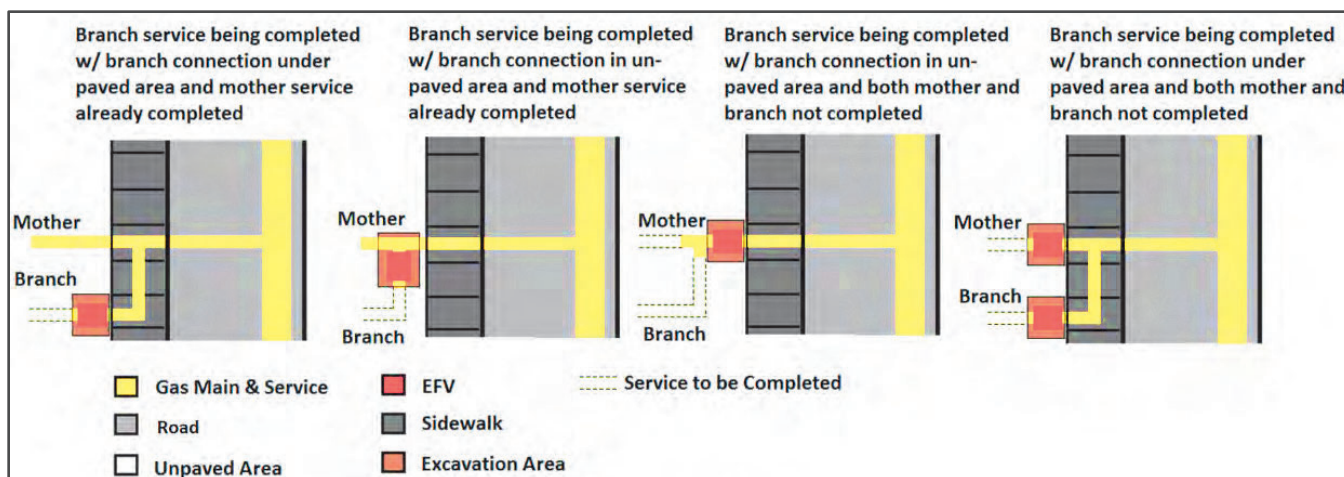


Figure 3. EFV Locations on Common Branch Installation Scenarios

- C. To complete a ½" stub service:
- (1) Select a ½" EFV per Table 8, and install the EFV at the appropriate location per Figure 2 and Figure 3. Use 1" plastic pipe for the remainder of the service completion.
  - (2) If a ½" EFV series does not meet the customer loads as described in Table 8, upsize the stub, EFV, and service completion to 1" plastic and size the EFV accordingly.
  - (3) If the stub completion requires more than 150' of 1" piping, contact standards engineering personnel for guidance or variance options.

Table 8. EFV Selection for ½" Stub Completions

	Length of ½" Stub <sup>1</sup> (ft)	Total Connected Load (scfh)		
		0–385	386–595	595–700
NOP <24 psig	0–23	1" or ½" – Honeywell Perfection 800	1" or ½" – 800	1" or ½" – 800
	24–40	½" – 600	½" – 600	Replace all with 1"
	41–117	½" – 400	Replace all with 1"	
NOP ≥24 psig	0–60	1" or ½" – 800	1" or ½" – 800	1" or ½" – 800
	61–100	½" – 600	½" – 600	Replace all with 1"
	101–245	½" – 400	Replace all with 1"	

1. Stub length is measured from gas main to the end of the longest stub.

Printed copies of this document might be out of date. The Technical Information Library (TIL) has the current version.

**Excess Flow Valves****A-93.3**

Publication Date: 10/20/2021 Effective Date: 01/01/2022 Rev. 9c

**7 General EFV Installation Instructions**

- 7.1. Do **not** squeeze an EFV.
- 7.2. Plastic EFVs with factory-installed pipe pups may be cut on the pup ends as needed for proper installation; however, steel EFVs may not be cut to reduce their length.
- 7.3. In most cases, an EFV with plain pipe ends may be connected directly to the service tee, but a short piece of pipe may be installed between the service tee and EFV as needed.
- 7.4. Remove debris from the service line before installing an EFV.

**CAUTION**

An EFV installed with the flow direction going the wrong way will flow normally but will not activate.

- 7.5. When installing the EFV, ensure the directional arrow is in line with the flow of the gas and pointing toward the gas meter.
- 7.6. Use an appropriate welding procedure when installing a steel EFV. When welding a steel EFV, place a wet rag over the center of the steel EFV stick while it is being welded in place. Keep welding heat away from the center of the EFV stick.
- 7.7. The EFV is supplied with metal identification tags, while some models are also supplied with an adhesive sticker.
  - A. Use the supplied nylon tie to install the metal tag.
  - B. Install the metal tag on the gas service riser at the gas service valve location.
  - C. Install the adhesive sticker (if supplied) on the pressure regulator.
  - D. For a branch service line, place a metal tag on the riser for each meter set. Extra metal tags may be purchased using material code M020957. Follow GDS A-42, "Standard Branch Service Installation," for additional branch marking requirements.
- 7.8. Install EFVs on new stub service lines as close as possible to the gas main.
  - A. Leave the metal tag and adhesive sticker (if supplied) in the EFV plastic bag.
  - B. Wrap the bag around the buried stub.
  - C. Attach the metal tag on the riser and sticker (if supplied) to the pressure regulator when the service line is completed.
  - D. Ensure a properly sized EFV is present when performing a stub completion, if required.

Printed copies of this document might be out of date. The Technical Information Library (TIL) has the current version.

**Excess Flow Valves****A-93.3****Publication Date:** 10/20/2021 **Effective Date:** 01/01/2022 Rev. 9c

## 7.9. Leak Testing

- A. When leak-testing a service line that has an EFV, as required in GDS A-34, "Piping Test Design Requirements," increase the air pressure slowly. A high flow may cause the EFV to trip. For example, take 15 seconds to pressurize a typical 50"–100" service line of ½" or 1" CTS.
- B. Depressurize the service at a slow flow rate to avoid tripping the EFV.

## 7.10. Purging

- A. Gas service lines with an EFV require a slower purge velocity than the normal gas purge procedure described in GDS A-38, "Purging Gas Facilities."
- B. Do not attempt to purge a gas main through a service that has an EFV.
- C. Confirm there is an EFV identification tag on the gas service valve, service riser, riser sun shield, or pressure regulator. If the tag is present, an EFV has already been installed on the service.
- D. Open the gas service valve very slowly and only partially.
  - If the valve is fully opened, the resulting rapid flow of gas will activate and trip the EFV.
  - The EFV may activate when purging to atmosphere even if the gas valve is opened slowly.
  - If the EFV activates during purging, shut off the gas service valve and wait until the pressure equalizes before attempting to continue purge.
- E. When performing service work downstream of the regulator at the meter set, avoid removing a plug or associated piping too quickly because doing so can activate the EFV.
- F. If the EFV activates, shut off the service valve and wait for the pressure to equalize. A typical EFV takes approximately 5 minutes to equalize.

**8 Customer Notification**

- 8.1. If a customer's service line operates at a pressure of 10 psig or greater throughout the year, PG&E must provide written or electronic notification to the customer of their right to request the installation of an EFV as specified in Code of Federal Regulations (CFR) Title 49, Transportation, Part 192—Transportation of Natural and Other Gas by Pipeline: Minimum Federal Safety Standards, Section (§) 192.383, "Excess flow valve installation."

Printed copies of this document might be out of date. The Technical Information Library (TIL) has the current version.

**Excess Flow Valves****A-93.3****Publication Date:** 10/20/2021 **Effective Date:** 01/01/2022 Rev. 9c**Target Audience**

Gas distribution engineering and estimating personnel, maintenance and construction personnel, general construction personnel, contractors, applicant designers, and inspectors.

**Definitions**

Branch service line	A gas service line that is not directly connected to a gas main but has another service line as its source of supply.
Farm tap regulator set	A pressure regulator set, including both single and multiple stages of pressure regulation, that controls pressure to a service line.
Nominal operating pressure (NOP)	The operating pressure of a system that is generally the set point of the working regulator.
Total connected load	Total demand of all gas appliances operating simultaneously and at full capacity.

**Compliance Requirement / Regulatory Commitment**

Code of Federal Regulations (CFR) Title 49, Transportation, Part 192—Transportation of Natural and Other Gas by Pipeline: Minimum Federal Safety Standards, Section 192.381, “Service lines: Excess flow valve performance standards.”

Code of Federal Regulations (CFR) Title 49, Transportation, Part 192—Transportation of Natural and Other Gas by Pipeline: Minimum Federal Safety Standards, Section 192.383, “Excess flow valve installation.”

**Records and Information Management:**

Information or records generated by this procedure must be managed in accordance with the Enterprise Records and Information (ERIM) Policy, Standards and Enterprise Records Retention Schedule (ERRS). Refer to GOV-7101S, “Enterprise Records and Information Management Standard,” and related standards. Management of records includes, but is not limited to:

- Integrity
- Storage
- Retention and Disposition
- Classification and Protection

Printed copies of this document might be out of date. The Technical Information Library (TIL) has the current version.

**Excess Flow Valves****A-93.3****Publication Date:** 10/20/2021 **Effective Date:** 01/01/2022 Rev. 9c**References**

American Society for Testing and Materials (ASTM International) A53, "Standard Specification for Pipe, Steel, Black and Hot-Dipped, Zinc-Coated, Welded and Seamless"

American Society for Testing and Materials (ASTM International) F1802, "Standard Test Method for Performance Testing of Excess Flow Valves"

American Society for Testing and Materials (ASTM International) F2138, "Standard Specification for Excess Flow Valves for Natural Gas Service"

Gas Design Standard A-34, "Piping Test Design Requirements"

Gas Design Standard A-38, "Purging Gas Facilities"

Gas Design Standard A-42, "Standard Branch Service Installation"

Gas Design Standard A-43.2, "Curb Valves"

Gas Design Standard D-34, "Qualifications for Joining Polyethylene Pipe"

Gas Design Standard H-10, "High-Pressure Regulator-Type Stations and Farm Tap Regulator Sets"

Gas Design Standard J-10.1, "Diaphragm Meter Capacities"

Gas Design Standard J-20, "Rotary Meter Capacity – At Standard and Elevated Delivery Pressures"

Utility Standard TD-4801S, "Service Replacement Criteria"

**Appendices**

[Appendix A, "Pressure Drop Across EFVs"](#)

[Appendix B, "Calculating Equivalent Lengths of Plastic Pipe"](#)

[Appendix C, "EFV Installation and Replacement Matrix"](#)

**Attachments**

Attachment 1, "Excess Flow Valve (EFV) Calculator"

Printed copies of this document might be out of date. The Technical Information Library (TIL) has the current version.

**Excess Flow Valves****A-93.3****Publication Date:** 10/20/2021 **Effective Date:** 01/01/2022 Rev. 9c**Revision Notes**

Revision 9c has the following changes:

1. Updated Section 3 as follows:
  - a. In Step 3.6.A, deleted any mention of Honeywell Perfection EFVs (except in Step 3.6.A.4), GasBreaker, and plastic Lyall. Added “with plain ends,” “with socket ends,” and “incorporated into plastic electrofusion couplings.”
  - b. Added new step (Step 3.10) to refer to Appendix A.
2. Completely revised Section 4, including the following:
  - a. Grouped plastic EFVs by connection type rather than by manufacturer.
  - b. Added manufacturer's part numbers to the tables.
  - c. Added three additional GasBreaker EFVs with plain ends.
  - d. Merged GasBreaker EFVs with plain ends with Honeywell Perfection EFVs with plain ends under one material code for the same size and flow series. Maximum protected length of 1¼” IPS 2600 and 2 IPS 5000 Honeywells were reduced to align with GasBreaker.
  - e. Added MAXITROL as a new EFV manufacturer.
3. Added to Step 7.7 and Step 7.8 that adhesive stickers are not required if not supplied in the bag with the EFV.
4. Removed option to keep original EFV in place if or when transferring a service to a new main.
5. Merged cells in Appendix C (row 11, columns 3 and 4).
6. Added new Attachment 1 (Excel) to assist in sizing the EFVs.

Revision 9b (Publication Date: 04/01/2021; Effective Date: 06/15/2021) has the following changes:

1. Added GasBreaker Model 51 plastic EFVs now approved for use.
2. Advanced table numbering throughout for new Table 4.

Revision 9a (Publication Date 03/17/2021, Effective Date 06/15/2021) has the following changes:

1. Added new Step 2.1.A to clarify what is meant by a new service line in Table 1.

Printed copies of this document might be out of date. The Technical Information Library (TIL) has the current version.

**Excess Flow Valves****A-93.3****Publication Date:** 10/20/2021 **Effective Date:** 01/01/2022 Rev. 9c

- 
2. In Table 1, added Step 2.1.A reference to expand on footnote 2.
  3. Revised Step 3.3, adding meter badge rating larger than 1,000 scfh (CAPn 120228322).
  4. Revised Step 3.5, removing converting from NOP to design pressure and adding that non-estimated work can use gauge pressure for NOP.
  5. In Table 3, Table 4, and Table 6, replaced “design pressure” with “NOP” in the header and removed conversion from NOP to design pressure in the footer.
  6. In Table 3 and Table 4, added using 2” 5500 EFV with two 2”×1¼” reducers.
  7. Added new Section 8, “Customer Notification.”

Revision 9 (Publication Date: 07/27/2020; Effective Date: 10/27/2020) has the following changes:

1. Rearranged entire GDS, added new sections for better usability, and incorporated previous attachments into the body of the GDS.
2. Clarified that there is no minimum load requirement on EFVs.
3. Updated [Table 1](#) to clarify when EFVs are required.
4. Updated [Table 3](#), [Table 4](#), [Table 5](#) and [Table 6](#) to incorporate maximum service length of EFVs at 10 pounds per square inch gauge (psig) and 20 psig design pressure.
5. Updated load capacity and maximum protected length for Lyall EFVs that have socket fusion ends.
6. Clarified if multiple EFV models can be used for a certain scenario, it is recommended to choose the EFV with the highest capacity.
7. Added new guidance for EFV installation location guidelines on branched service lines.
8. Added new [Appendix A](#).
9. Added new [Appendix B](#).
10. Moved “EFV Installation and Replacement Matrix” to new [Appendix C](#).
11. Developed a “Frequently Asked Questions” (FAQ) document (stored in the Technical Information Library) to address commonly asked EFV questions.

**Asset Type:** Distribution Services

**Function:** Design, Construction, Maintenance

**Document Contact:** [Gas Design Standard Responsibility List](#)

---

Printed copies of this document might be out of date. The Technical Information Library (TIL) has the current version.

**Excess Flow Valves**

**A-93.3**

Publication Date: 10/20/2021 Effective Date: 01/01/2022 Rev. 9c

**Appendix A, Pressure Drop Across EFVs**

See Table A-1 for data on maximum pressure drop values across EFVs, and use these values as references, if needed.

**Table A-1. Maximum Pressure Drop Values Across EFVs**

Plastic EFVs		
Size (in.)	Type and EFV Flow Series	Maximum Pressure Drop (psig)
½ CTS	Perfection 400	0.75
	Perfection 600	1.90
	Perfection 800	1.40
	Lyll 400	0.41
	Lyll 775	1.53
1 CTS	Perfection 800	1.40
	Perfection 1100	3.00
	Perfection 1800	3.20
	Lyll 775	0.76
	Lyll 1200	1.35
1¼ IPS	Lyll 1800	3.00
	Perfection 2600	4.90
2 IPS	Lyll 2600	0.56
	Perfection 5500	0.50
	Lyll 5500	0.67
Steel EFVs		
Size (in.)	Type and EFV Flow Series	Maximum Pressure Drop (psig)
¾ NPS	Perfection 800	1.40
	Perfection 1100	3.00
	Perfection 1800	3.20

*cited in Cal. Rest. Ass'n v. City of Berkeley  
No. 21-16278sm archived December 27, 2023*



**Excess Flow Valves****A-93.3**

Publication Date: 10/20/2021 Effective Date: 01/01/2022 Rev. 9c

**Appendix B, Calculating Equivalent Lengths of Plastic Pipe**

For flows governed by the Mueller formula (typically high-pressure gas flow in plastic pipe), a length ( $L_1$ ) of pipe of one internal diameter ( $D_1$ ) can be converted to an equivalent length ( $L_2$ ) of pipe of a second internal diameter ( $D_2$ ) by applying the following formula:

$$L_2 = L_1 \times \left[ \frac{D_2}{D_1} \right]^{4.73913}$$

See Table B-1 for the minimum inside diameter (ID) of PE pipe sizes ½" CTS through 2" IPS.

**Table B-1. Minimum ID of Plastic Pipe**

Nominal Pipe Size (in.)	Minimum ID
½ CTS	0.423
1 CTS	0.898
1¼ IPS	1.283
2 IPS	1.885

**Example 1:** Converting 100' of ½" plastic (PL) to 1" PL

Minimum ID ½" CTS = 0.423";

Minimum ID 1" CTS = 0.898";

In this scenario, 100' of ½" plastic would be equivalent to  $100 \times (0.898/0.423)^{4.73913} = 3543.2'$  of 1" plastic.

**Example 2:** Converting 100' of 1" PL to ½" PL

Minimum ID 1" CTS = 0.898";

Minimum ID ½" CTS = 0.423"

In this scenario, 100' of 1" plastic would be equivalent to  $100 \times (0.423/0.898)^{4.73913} = 2.8'$  of ½" plastic.

Printed copies of this document might be out of date. The Technical Information Library (TIL) has the current version.

**Excess Flow Valves****A-93.3**

Publication Date: 10/20/2021 Effective Date: 01/01/2022 Rev. 9c

**Appendix C, EFV Installation and Replacement Matrix**

See Table C-1 for EFV installation scenarios and their recommended actions.

**Table C-1. EFV Installation and Replacement Matrix**

Scenario	EFV Installed	Action	Charge To
Customer requests new gas service. A new single service line is installed.	No	Engineered job: Install a new EFV that has the appropriate capacity.	New Business
Customer adds load to a single service line. The service is completely replaced.	Yes		
Customer adds load to a single service. The service line is altered to accommodate the load.	No	Check the EFV's capacity, and replace it if the capacity is inadequate.	WRO
	Yes	Install a new EFV if the alteration is within 3' of the service tee/saddle.	WRO
Customer adds load, but no service line reinforcement work is performed.	No	Check the EFV's capacity, and replace it if the capacity is inadequate <sup>1</sup> .	New Business
	Yes	No EFV installation is required.	NA
Customer requests service line to serve new or existing load. A new service is branched off an existing service.	No	Check the EFV's capacity, and replace it if the capacity is inadequate.	New Business
	Yes	Engineered job: Install a new EFV. See the "EFV Installation Locations Guidelines" section for details.	New Business
Customer requests additional meter on manifold.	No	Check the EFV's capacity, and replace it if the capacity is inadequate.	New Business
	Yes	No EFV installation is required.	NA
Developer does a lot flop. PG&E deactivates the old stub and installs new service at the new service point.	No	Engineered job: Install a new EFV that has the appropriate capacity.	WRO <sup>2</sup>
	Yes		
Customer requests an EFV on an existing service line.	No	Engineered job (service alteration): Install a new EFV <sup>1</sup> .	WRO <sup>2</sup>
The EFV is leaking or has failed.	Yes	Replace the EFV.	Maintenance
The service is replaced as part of a gas pipeline replacement program (GPRP), reliability, or capacity job.	No	Engineered job: Install a new EFV that has the appropriate capacity.	Capital Job
	Yes		Capital Job
The service is transferred as part of a GPRP, reliability, or capacity job.	No	Engineered job: Install a new EFV that has the appropriate capacity.	Capital Job
	Yes		Capital Job
Existing service line is cut off at property line by PG&E to facilitate work by customer and is reconnected later.	Yes	Same load: Leave current EFV.	NA
		Added load: Check EFV capacity, and replace it if the capacity is inadequate.	WRO <sup>2</sup>
	No	Install EFV at time of reconnection.	NA

1. If the service line size is increased to meet the EFV maximum protected service limitation, bill the applicant under New Business or WRO, as appropriate.
2. Reimbursable WRO.

Printed copies of this document might be out of date. The Technical Information Library (TIL) has the current version.

cited in Cal. Rest. Ass'n v. City of Berkeley  
No. 21-16278am archived December 27, 2023



## GAS DESIGN STANDARD MOBILE HOME/MANUFACTURED HOME METER SET INSTALLATION

J-12.4

Publication Date: 10/17/2018 Effective Date: 10/17/2018 Rev. 1

### Purpose and Scope

This Gas Design Standard (GDS) provides application requirements and ordering information and describes the installation of gas meter sets for mobile homes or manufactured homes in a mobile home park.

### General Information

1. Install gas meter sets supplying mobile homes and manufactured homes in accordance with this GDS.
2. A flexible connector meeting the requirements of American National Standards Institute (ANSI) Z21.75/CSA 6.27 and approved by the California Department of Housing and Community Development (HDC) for outdoor use must be provided and installed by the customer to connect the customer's mobile home or manufactured home piping to the gas meter set outlet. Approved connectors are identified with the ANSI/Canadian Standards Association (CSA) specification number on an attached label or tag, or permanently stamped on an end connection fitting.
3. Pacific Gas and Electric Company (PG&E or Company) piping in the meter set terminates with the 3/4" fitting on the meter outlet as shown in [Figure 1](#).
4. Install the meter using a meter stake shown in [Figure 1](#).

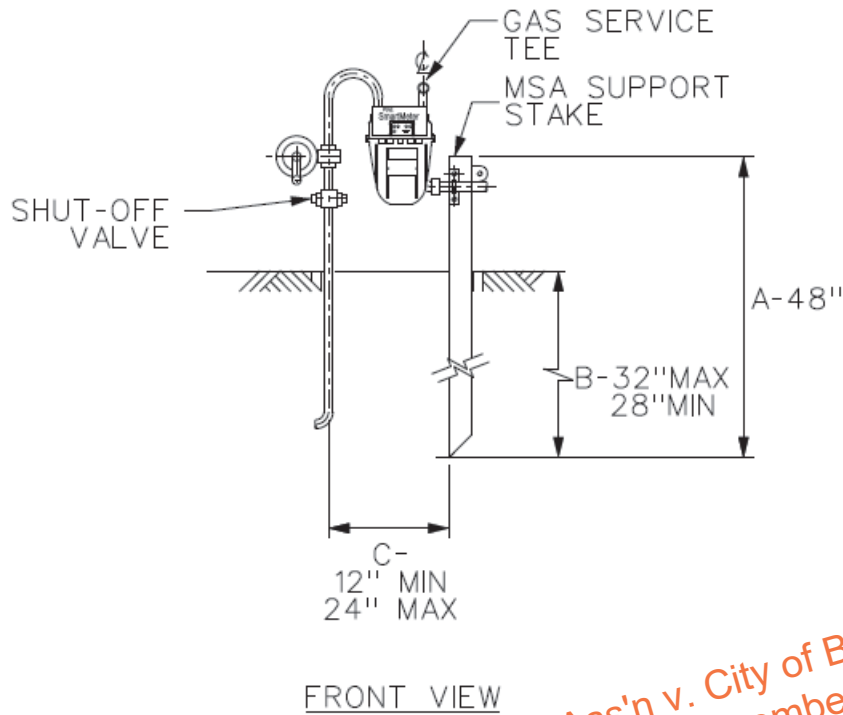
### Specific Information

1. A meter stake:
  - A. Can only be installed in locations identified in [Figure 2](#).
  - B. Is 2" x 2" x 3/16" angle iron. 48" long hot dip galvanize with grey polyester powder overcoat on top 22" shown in [Figure 3](#).
  - C. Must be installed plumb and level in the ground up to the bury line identified on the stake between 28" and 32" deep.
  - D. Must be installed in well compacted soil or in concrete as shown in [Figure 1](#).
2. Meter set outlet piping must be attached using insulated U-bolt and insulating pad that is provided with the meter stake. Piping can be attached per Option A or B as shown in [Figure 4](#).
3. For a detailed list of components see [Table 1](#).

Mobile Home/Manufactured Home Meter Set Installation

J-12.4

Publication Date: 10/17/2018 Effective Date: 10/17/2018 Rev. 1



*cited in Cal. Rest. Ass'n v. City of Berkeley  
No. 21-16278am archived December 27, 2023*

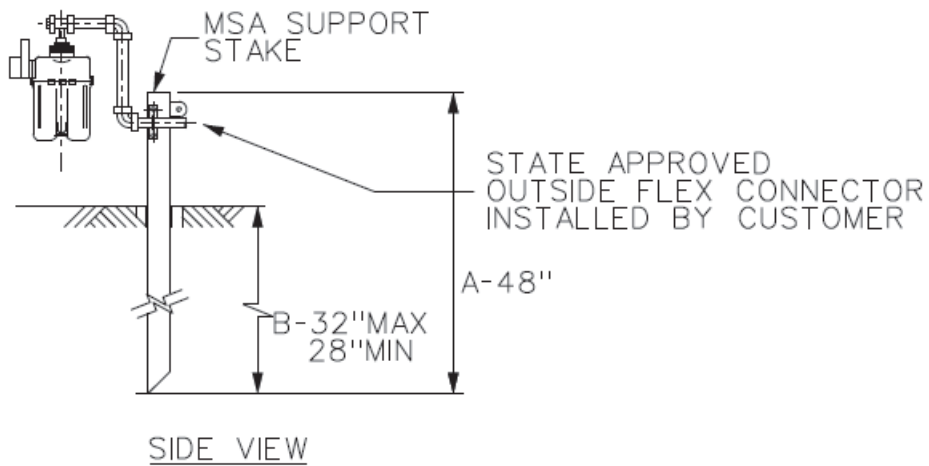


Figure 1. Mobile Home Diaphragm Meter Set – Profile View

### Mobile Home/Manufactured Home Meter Set Installation

J-12.4

Publication Date: 10/17/2018 Effective Date: 10/17/2018 Rev. 1

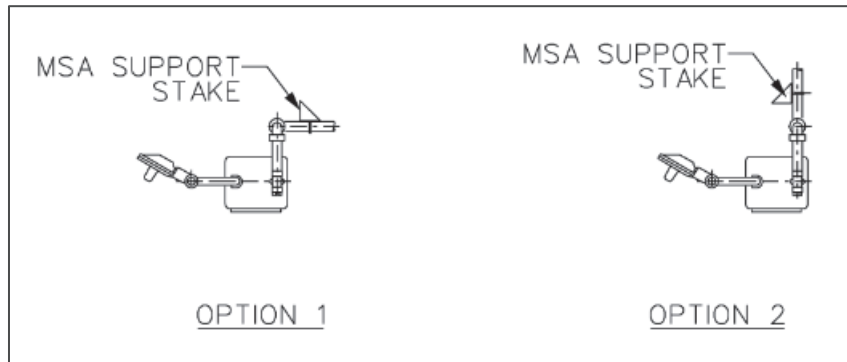
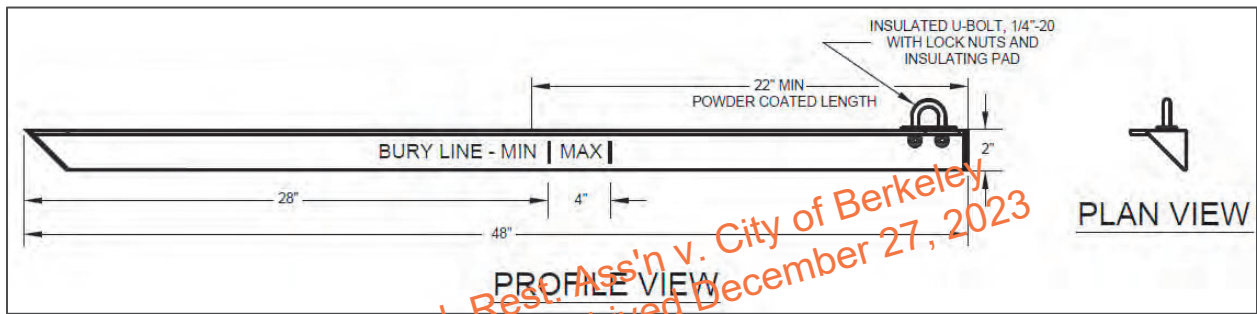


Figure 2. Mobile Home Diaphragm Meter Set – Plan View



*cited in Cal. Rest. Ass'n v. City of Berkeley  
No. 21-16278am archived December 27, 2023*

Figure 3. Meter Stake

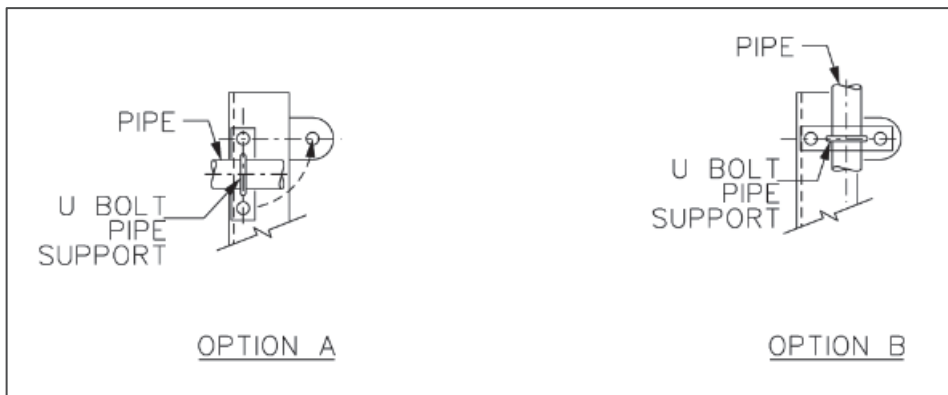


Figure 4. U-Bolt Detail

**Mobile Home/Manufactured Home Meter Set Installation****J-12.4****Publication Date:** 10/17/2018 **Effective Date:** 10/17/2018 **Rev.** 1**Table 1. Material List**

Item	Description	Quantity	Code	GDS
1	Gas Meter Connection Kit	1	M040945	B-16
2 <sup>1</sup>	Single Meter Loop	1 <sup>1</sup>	M040140	B-16
2A <sup>1</sup>	Domestic Regulator	1 <sup>1</sup>	Various	Various
3	Gas Meter with SmartMeter Module <sup>2</sup>	1	M231932	J-94
4	Elbow, standard NPT, 3/4"	Varies, build to suit	M020250	B-12
5	Swivel, male straight, #1A x 3/4"	1	M041426	J-50
6	Nut, swivel, #1A	1	M040099	J-50
7	Washer, swivel, #1A	2	M040160	J-50.2
8	Tee, standard NPT, 3/4"	1	M020902	B-14
9	Plug, standard NPT, 3/4"	1	M020774	B-10.1
10	Meter stake	1	M234167	J-12.4
11	Nipple, standard NPT, 3/4" x length to suit	Varies, build to suit		B-13

<sup>1</sup> Items 2 and 2A are only used when an insulated Jomar riser valve is not installed on the riser.

<sup>2</sup> Substitute meter with standard index code number 230053 for non-SmartMeter opt out customers.

**Target Audience**

All personnel who install meter sets (and their supervisors), including field services; gas maintenance and construction (M&C); general construction (GC); gas pipeline operations and maintenance (GPOM); gas estimators; distribution engineers; gas measurement and regulation engineering.

**Definitions**

NA

**Acronyms and Abbreviations**

MSA: Meter Set Assembly

**Compliance Requirement / Regulatory Commitment**

NA

*cited in Cal. Rest. Ass'n v. City of Berkeley  
No. 21-16278am archived December 27, 2023*

**Mobile Home/Manufactured Home Meter Set Installation****J-12.4****Publication Date:** 10/17/2018 **Effective Date:** 10/17/2018 **Rev. 1****References**

*Electric and Gas Service Requirements* (Greenbook), Section 2, "Gas Service"

GDS B-10.1, "Standard Pipe Plugs"

GDS B-12, "Standard 90° Threaded Elbows"

GDS B-13, "Standard Threaded Pipe Nipple"

GDS B-14, "Standard Threaded Tee"

GDS B-16, "Gas Meter Connection Kits for Residential (#1A Connection Size) Diaphragm Meters"

GDS J-50, "Meter Swivels and Swivel Nuts"

GDS J-50.2, "Gas Meter Swivel Washers"

GDS J-94, "Gas Meter Selection Guide for New Meter Sets"

**Appendices**

NA

**Attachments**

NA

**Revision Notes**

Revision 1 has the following changes:

1. This change removes the concrete block used for meter support and now requires the use of a meter stake.
2. Material list has been updated based on meter stake design.

**Asset Type:** Measurement & Control, Distribution Services, Customer Connected Equipment.

**Function:** Design and Construction

**Document Contact:** [Gas Design Standard Responsibility List](#)

cited in Cal. Rest. Ass'n v. City of Berkeley  
No. 21-16278am archived December 27, 2023



cited in Cal. Rest. Ass'n v. City of Berkeley  
No. 21-16278am archived December 27, 2023



## GAS DESIGN STANDARD GAS METER LOCATIONS

J-15

Publication Date: 08/18/2021    Effective Date: 11/01/2021    Rev. 9a

### Purpose and Scope

This gas design standard (GDS) outlines the requirements for complying with applicable federal and state codes when installing gas meter sets for residential and commercial premises.

This document includes definitions, references, and standard designs that support compliance with regulations and codes for gas meter set locations. Local jurisdictions may have adopted codes and ordinances relating to customer facilities that could require consideration when designing gas meter sets. Compliance with applicable federal and state codes is mandatory for Pacific Gas and Electric Company (PG&E or Company) facilities. Compliance with local codes is mandatory for customer facilities.

### General Information

#### 1. Applicability

- A. Per Gas Rule 16, "Gas Service Extensions," all gas meter set equipment must be located at a protected location on applicant's premises as approved by the Company. PG&E is responsible for the design and final approval of the location for metering facilities. The preferred meter set location is outside and adjacent to the building being served. Customers must submit the requested meter set location with the application early in the planning stage to avoid delays. Typically, PG&E provides only one meter set for each dwelling unit or commercial unit and one service lateral to each building.
- B. New or customer-requested relocated meter sets must be installed in compliance with current regulations, standards, and codes.
- C. Existing meter sets may be repaired, altered, or rebuilt in their existing location provided the clearance requirements meet or are brought up to current standards.
- D. These requirements do not mandate retroactive compliance of existing meter sets unless unsafe conditions exist as determined by the Company. If the existing service line or metering equipment is altered, then compliance with this gas design standard is required.

#### 2. Applicable Regulations and Codes

Listed below are the pertinent Code of Federal Regulations (CFR) Title 49, Part 192—Transportation of Natural and Other Gas by Pipeline: Minimum Federal Safety Standards sections (§), that apply to gas meter set locations.

- 49 CFR § 192.353, "Customer meters and regulators: Location"
- 49 CFR § 192.355, "Customer meters and regulators: Protection from damage"
- 49 CFR § 192.357, "Customer meters and regulators: Installation"
- 49 CFR § 192.363, "Service lines: Valve requirements"
- 49 CFR § 192.365, "Service lines: Location of valves"

**Gas Meter Locations****J-15****Publication Date:** 08/18/2021 **Effective Date:** 11/01/2021 **Rev.** 9a

**Note:** All meter locations are subject to PG&E approval and review.

### 3. General Requirements

The following requirements comply with the regulations and codes.

#### A. General Meter Set Requirements

(1) Approved Meter Locations, listed in order of preference.

- (a) Meter set located outside a building.
- (b) Meter set located outside in an alcove or enclosure.
- (c) Meter set located in a breezeway.
- (d) Meter set located in a cabinet.

**Note:** PG&E considers approving Items (e) and (f) below only after Items (a) through (d) have been determined not possible or practical.

- (e) Meter set located in a buried vault, pit, or box (not permitted for new or remodeled services).
- (f) Meter set (excluding service shutoff valve) located inside a building in a gas meter room. See GDSU-16, "Gas Meter Room," for specific room requirements.

(2) Prohibited Meter Locations

For new or remodeled buildings, do not locate gas meter sets in the following areas:

- (a) In curb meter boxes or vaults for new services.
- (b) In living quarters, closets, toilet rooms, or bathrooms.
- (c) In garages without properly vented meter cabinets.
- (d) Behind fences that applicants can lock.
- (e) On steep slopes.
- (f) In areas where landscaping restricts access.
- (g) Within engine, boiler, heater, or electrical-equipment rooms.
- (h) Under display platforms or show windows in commercial buildings. This includes any permanent, elevated display floors or platforms associated with the window where the purpose of the window is to present a display to the public.

**Gas Meter Locations****J-15**

Publication Date: 08/18/2021 Effective Date: 11/01/2021 Rev. 9a

## 3.A. (continued)

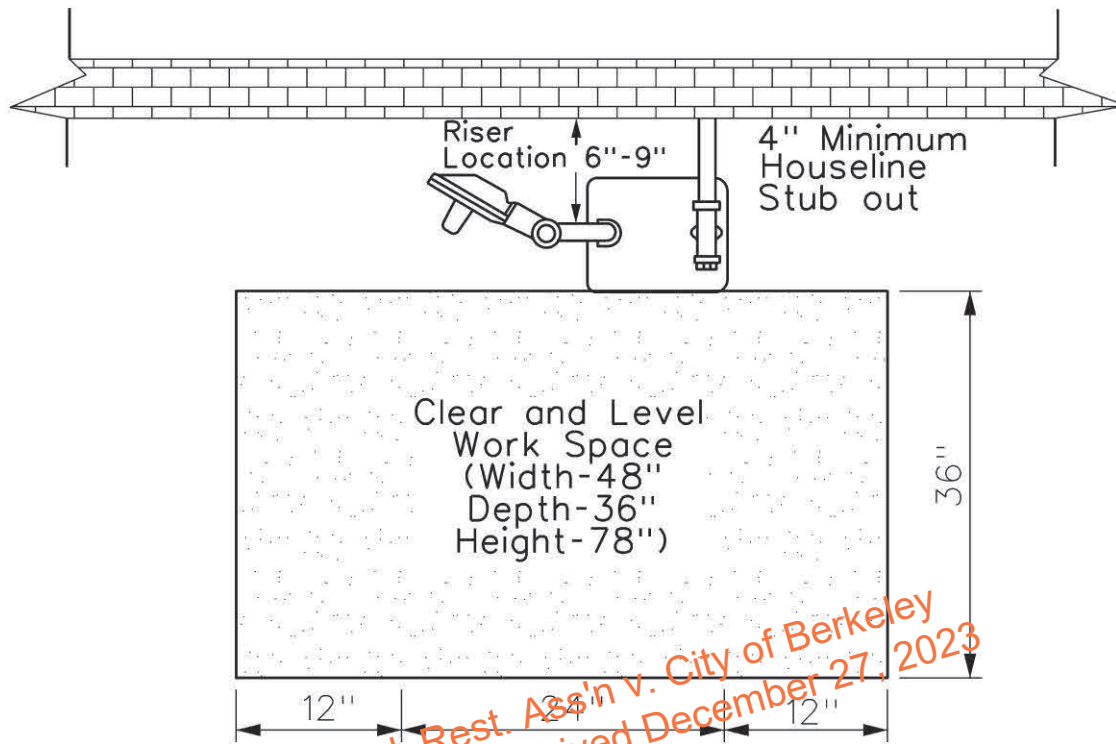
- (i) In contact with the soil, in a depression below general ground level, or where potentially corrosive materials are likely to contact the meter set.
  - (j) In a poorly-ventilated tradesman alley (passageway in a building, with a door at one end).
  - (k) In crawl spaces under buildings or decks.
  - (l) Near a driveway, drive-through, or other traveled area. Gas meters located in traveled ways must be adequately protected from passing vehicles, as described in GDS J-95, "Meter Guard Design and Installation Arrangement," Appendix C.
  - (m) In a metallic cabinet, room, or location that blocks or interferes with the radio frequency signal transmissions that are necessary for PG&E to operate its SmartMeter™ Advanced Meter Reading system.
  - (n) In any location that does not provide the required working space. The height dimension is 6 feet, 6 inches of clearance above ground and the depth dimension is 3 feet of clearance in front of the gas meter.
- (3) SmartMeter Module Location Requirements
- Specific SmartMeter module location requirements are detailed in Utility Manual TD-7001M, *Electric and Gas Service Requirements* (Greenbook), Section 2.4.F.12.
- (4) Gas Meter Working Space
- (a) Gas meter locations must be 78 inches high and allow for a minimum clear and level working space of 3 feet in front of the meter; width depends on meter size and the number of meters. Grade slope should be less than 2%. See [Figure 1](#) and [Figure 2](#). For a large meter set or multi-meter manifold, this working space extends 12 inches beyond the edge of the Company meter set equipment.
  - (b) [Figure 1](#) represents a typical gas meter kit with 0 through 350 scfh at 7 inches WC or 0 through 600 scfh at 2 pounds per square inch gauge (psig). Reverse sets are not allowed. The houseline must be to the right of the gas service riser.
  - (c) [Figure 2](#) represents a typical gas meter kit with 351 through 1400 scfh at 7 inches WC or 601 through 2400 scfh at 2 psig. Do not use reverse sets for 400 through 600 class meters (i.e., 400, 425, and 630). The houseline must be to the right of the gas service riser.

### Gas Meter Locations

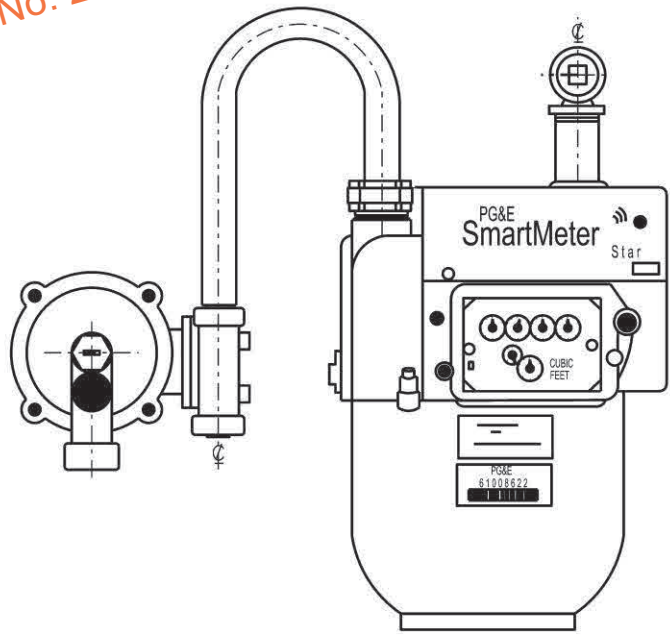
J-15

Publication Date: 08/18/2021 Effective Date: 11/01/2021 Rev. 9a

3.A. (continued)



*cited in Cal. Rest. Ass'n v. City of Berkeley  
No. 21-16278am archived December 27, 2023*

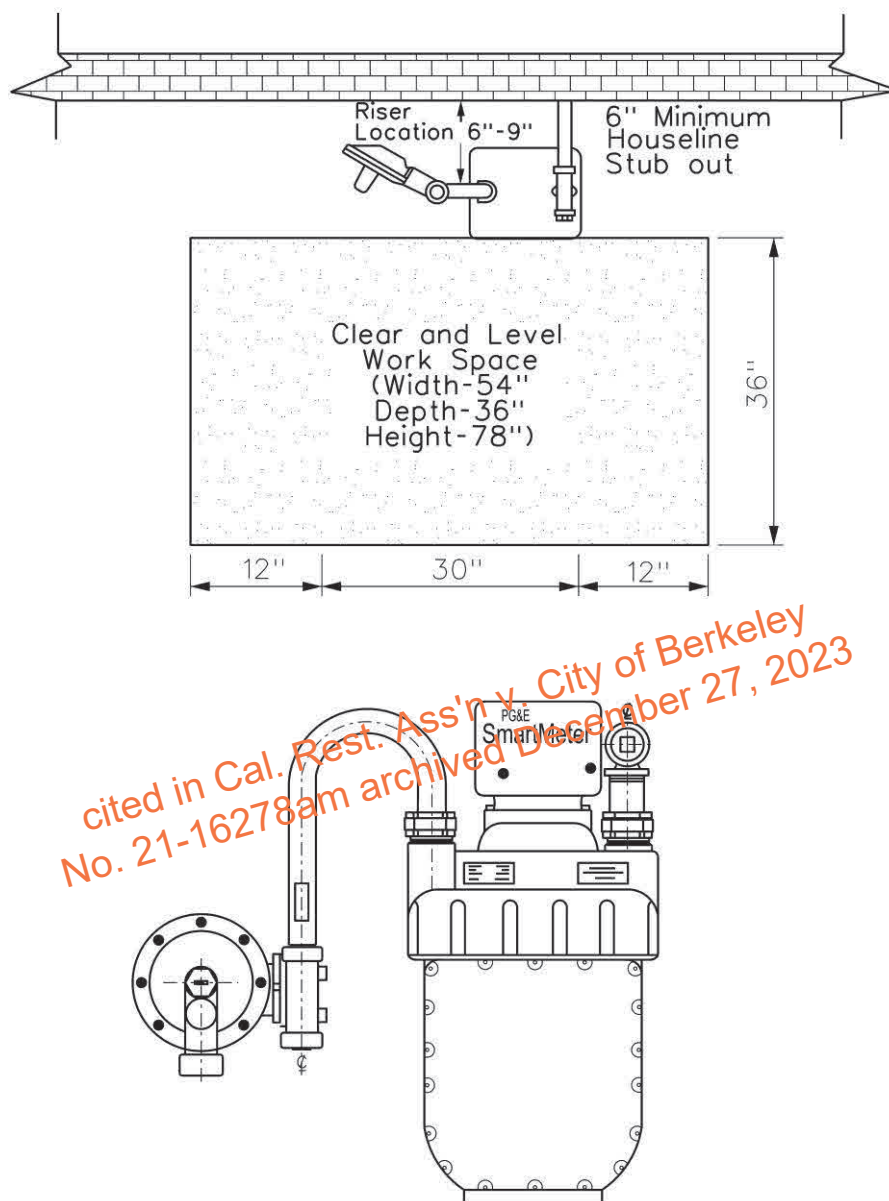


**Figure 1. Typical Residential Gas Meter Connection**

**Gas Meter Locations****J-15**

Publication Date: 08/18/2021 Effective Date: 11/01/2021 Rev. 9a

3.A. (continued)

**Figure 2. Typical Gas Meter Connection for 400 to 1000 Class Meter****(5) Meter Set Location Relative to Service Line**

The meter set is typically located so that the service line is the minimum possible length, measured in a straight line perpendicular to the main. The Company may consider an alternate route if it results in significantly lower construction costs or facilitates construction.

**Gas Meter Locations****J-15**

Publication Date: 08/18/2021 Effective Date: 11/01/2021 Rev. 9a

## 3.A. (continued)

## (6) Meter and Regulator Accessibility

Each meter set must be in a readily accessible location for reading, maintenance, inspection and replacement. It must be protected from corrosion and other damage that may be anticipated including vehicular damage. Large meter sets or multi-meter manifolds require adequate space for installation and maintenance and require drive-up access for the Company's service trucks.

## (7) Service Shut-Off Valve Locations

(a) Each service line must have a shut-off valve in a readily accessible location when:

- Services or risers are newly installed, relocated, or completely replaced OR
- Work is performed under the Meter Protection Program

(b) The location for the service shut-off valve is above ground on an outside riser in a readily accessible location.

(c) Service risers must not be installed inside buildings or meter rooms, except where special circumstances prevent outside installation as determined by the Company in accordance with GDS J-16. If the riser is located inside a building or an outside riser valve is not readily accessible, then a curb valve must be installed in a location that is readily accessible.

## (8) Meter Set Separated from Service Shut-Off Valve

If the meter set (or meter and regulator assembly) is located remotely from the service shut-off valve, then install an additional service shut-off valve at the meter set when performing new installations, replacing the meter, or altering or replacing the service. The additional valve facilitates maintenance and operation procedures.

## (9) Meter Set Clearance Requirements

The meter set and service regulator vents must terminate in a safe outside location that complies with the following criteria.

(a) The regulator vent must not terminate near any sources of ignition or openings into the building. The riser must be a minimum distance of 36 inches from sources of ignition and openings into the building, and this clearance area extends 10 feet above and 36 inches below the regulator vent termination. (See [Figure 3](#).) For a large meter set or multi-meter manifold, this clearance requirement extends 12 inches beyond the last service tee or end of the manifold, whichever is greater, Company meter set equipment, 10 feet above the highest regulator vent, and 36 inches below the lowest regulator vent.

**Gas Meter Locations****J-15**

Publication Date: 08/18/2021 Effective Date: 11/01/2021 Rev. 9a

## 3.A. (continued)

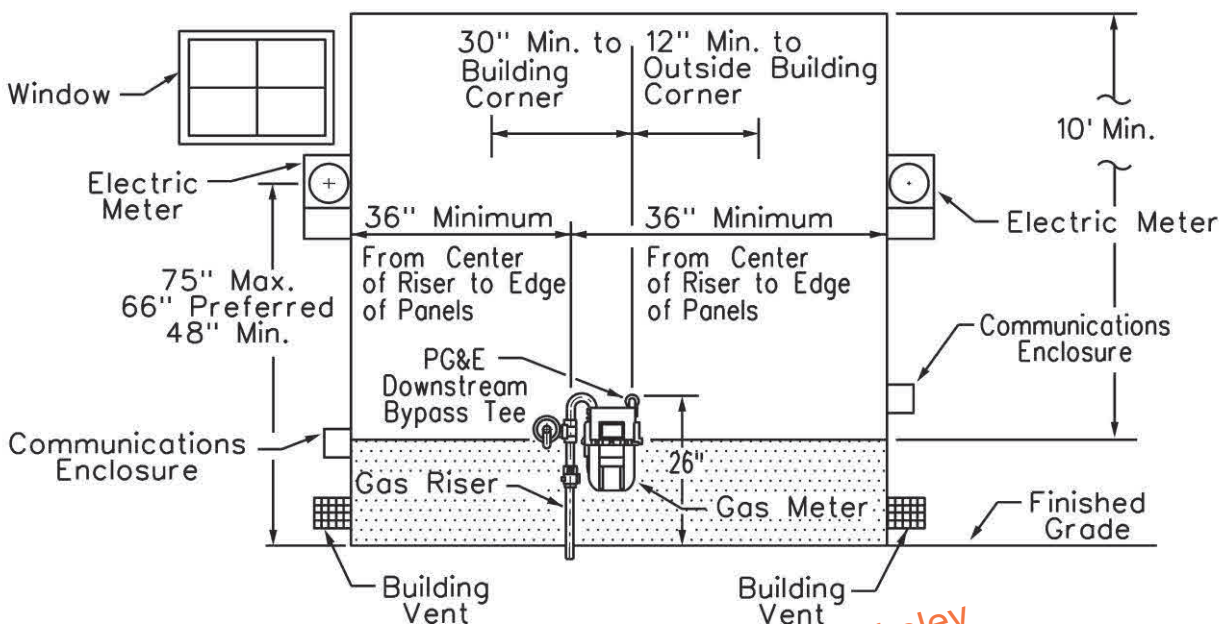


Figure 3. Gas Meter Set Separations

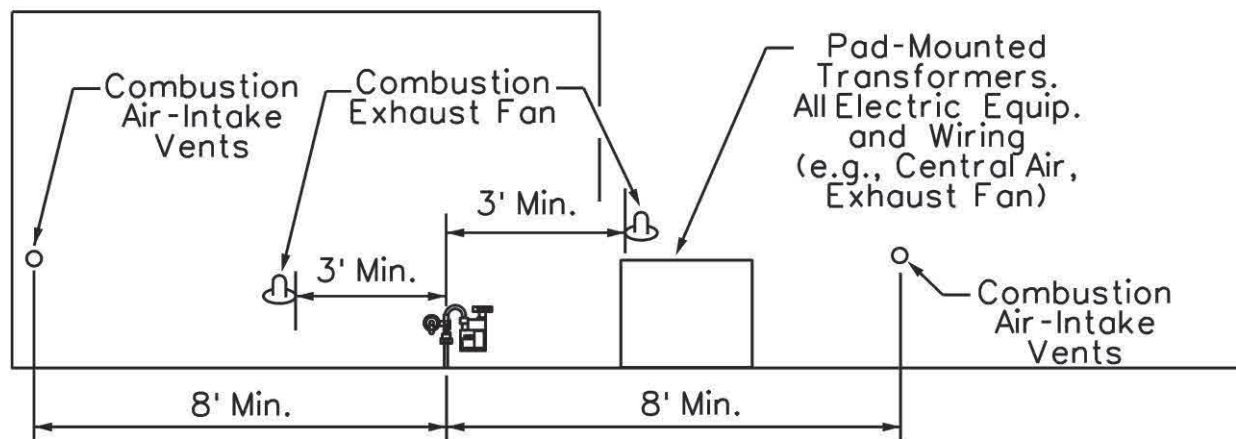
- Filed in Cal. Rest. Ass'n v. City of Berkeley No. 21-16278am archived December 27, 2023*
- (b) The regulator vent must not be within any location under building overhangs, where the overhang can direct gas into a building opening or any electrical devices under the overhang. Overhangs are acceptable if they direct gas away from a building (i.e., are sloped up and away from the building and cannot trap gas).
  - (c) The riser must be a minimum lateral distance of 8 feet from a forced air intake into the building. (See [Figure 4.](#)) For a large meter set or multi-meter manifold, this clearance requirement extends 8 feet beyond the edge of the Company meter set equipment. The 8-foot distance extends around corners of the building.



**Gas Meter Locations****J-15**

Publication Date: 08/18/2021 Effective Date: 11/01/2021 Rev. 9a

3.A. (continued)

**Figure 4. Requirements for Gas Regulator Set Clearance from Sources of Ignition**

- (d) The meter set must not be within any location that is under display platforms or show windows in non-residential buildings, including any permanent, elevated, display floors or platforms associated with the window.
- (10) Corrosion Protection
- Each meter set and service line must be installed to provide protection from corrosion and anticipated damage. The service and meter set location must allow inspection for operation and maintenance activities.
- (11) Meter Sets in Contact with Soil
- Meter sets must not be installed in contact with the soil, in a depression below general ground level (curb meters are an exception), or where potentially corrosive materials are likely to contact the meter set. The potential for accidental electrical shunting of the insulating fitting must be minimized.
- (12) Buried Lines Downstream of the Shut-Off Valve
- On an exception basis, as approved by the company, if it is necessary to bury any segment of the metering facility downstream of the service shutoff valve such locations must have adequate corrosion protection.

**Gas Meter Locations****J-15**

Publication Date: 08/18/2021 Effective Date: 11/01/2021 Rev. 9a

## 3.A. (continued)

## (13) Service Risers

- (a) Company-approved prefabricated, non-corrodible risers must be used. A minimum 3-inch casing will be required for the placement of the gas riser in areas that will be paved with concrete or asphalt. Gas service risers must not be directly embedded in concrete or asphalt pavements.
- (b) If it is necessary to pave (concrete or asphalt) before installing the gas service, refer to GDS A-75, "Gas Service and Mains in Plastic Casing."

## (14) Overpressure Protection

When any overpressure protection devices are required in addition to the final service regulator, refer to GDS H-15, "Design Requirements for Company-Owned Gas Regulating Systems Serving Customers."

## (15) Potential for Damage from Vehicles

Meter sets should be installed in locations where they are not exposed to damage from vehicular traffic. If there is a potential for damage to the meter set from vehicular traffic, refer to GDS J-95.

## (16) Working Space Around Electric Meter Sets

To provide required working space around an electric meter, the gas service riser may not be located less than 36 inches laterally from the closest edge of the electric meter panel. (See [Figure 3](#).) For a large gas meter set or multi-meter manifold, this clearance requirement extends 12 inches laterally beyond the edge of the Company gas meter set equipment.

## (17) Other Hazards

When selecting the meter set location, it is necessary to be alert to any potential hazards not specifically indicated in this document, including potential risk to others caused by the meter set, and exercise reasonable care to avoid any hazards. Electric grounding or bonding wires must not be attached to any part of the gas meter set. No bonding is permitted within 36 inches of PG&E meter set assembly on the customer houseline.

## (18) Service Delivery Point

- (a) All customer-installed equipment must be installed downstream of the Company point of connection as shown in [Figure 5](#). Customer-installed equipment may include: earthquake valves, seismic shutoffs, remote monitoring equipment, or flex hoses. Any customer-installed equipment on Company facilities must be removed at the customer's expense.
- (b) Company point of connection must be made to rigid pipe houseline and not to flex line.

Gas Meter Locations

J-15

Publication Date: 08/18/2021 Effective Date: 11/01/2021 Rev. 9a

3.A. (continued)

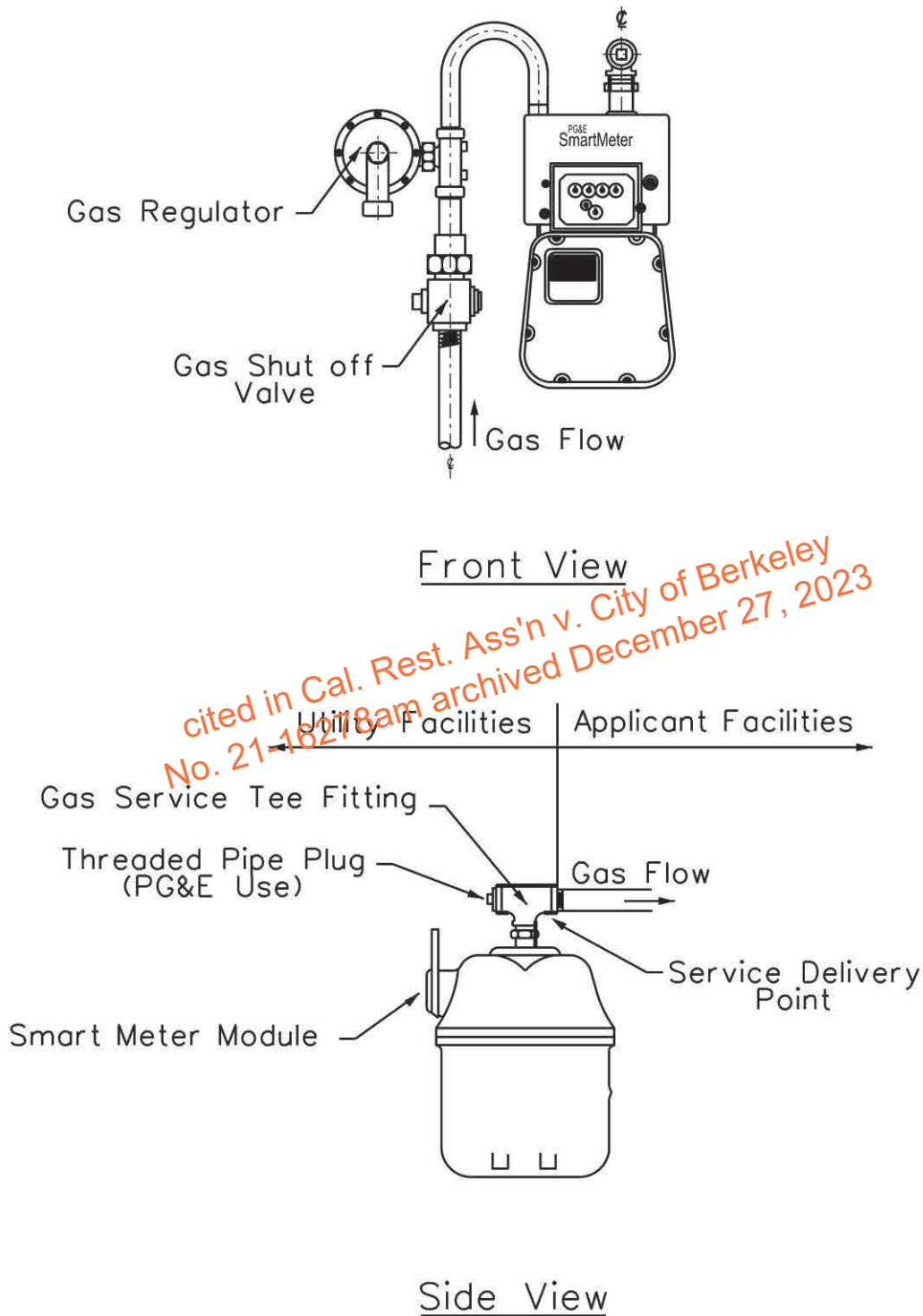


Figure 5. Typical Residential/Small Commercial Meter

**Gas Meter Locations****J-15**

Publication Date: 08/18/2021 Effective Date: 11/01/2021 Rev. 9a

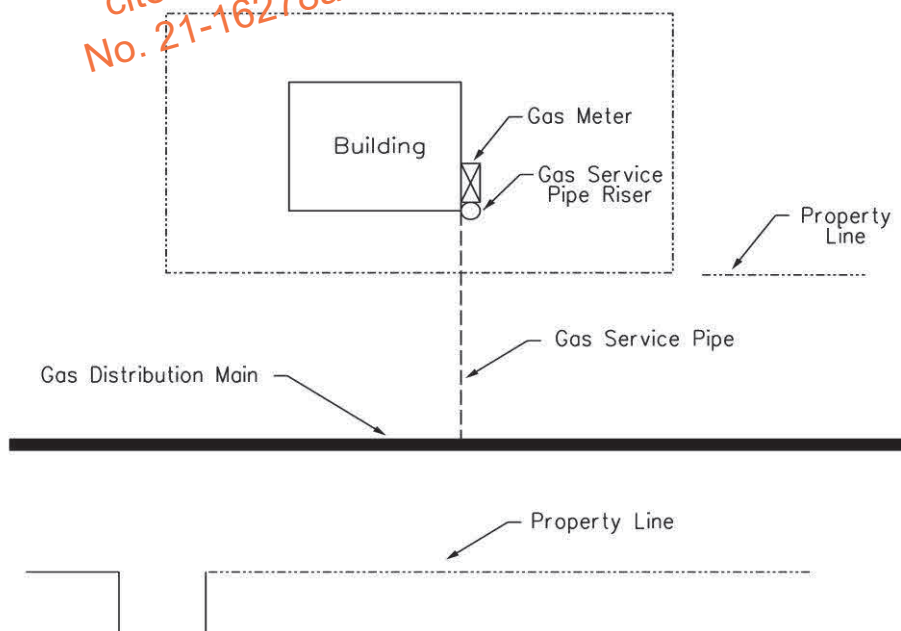
**B. Specific Requirements for Outside, Aboveground Meter Sets****(1) Location**

Meter sets should be located at the building and as near as practical to the point where the gas service pipe enters the property. The meter set location is typically near the side of the building from which the customer will be served. The order of preference for locating the outside, aboveground meter set is as follows.

- (a) In a protected location adjacent to the building served (see Figure 6, below). An exception to this requirement is for schools, where it is required to protect the meter set by installing it in a location that is separated from buildings and playground areas. It will be necessary to install a protective enclosure or wire cage with a cover around the meter set in these cases. (See [Figure 7](#) and [Figure 8](#).)
- (b) At the customer's property line, if a location exists where the meter set can be properly protected from damage by vehicles and anticipated damage. The service and meter set location must allow inspection for operation and maintenance activities. (See [Figure 9](#).)

**(2) Meter Set Accessibility**

For ease of access, avoid locations behind fences or other barriers that may be kept locked by the customer.

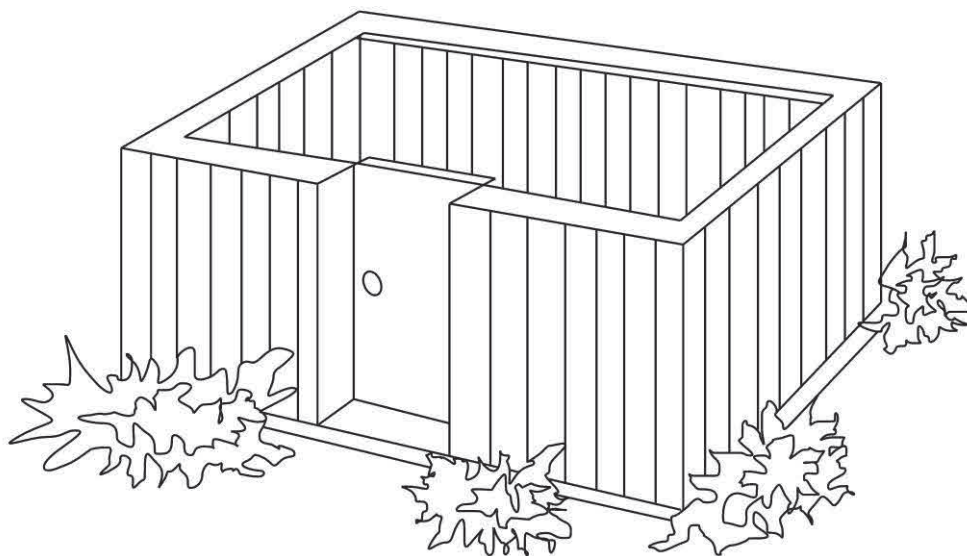
**Figure 6. Gas Service**

**Gas Meter Locations**

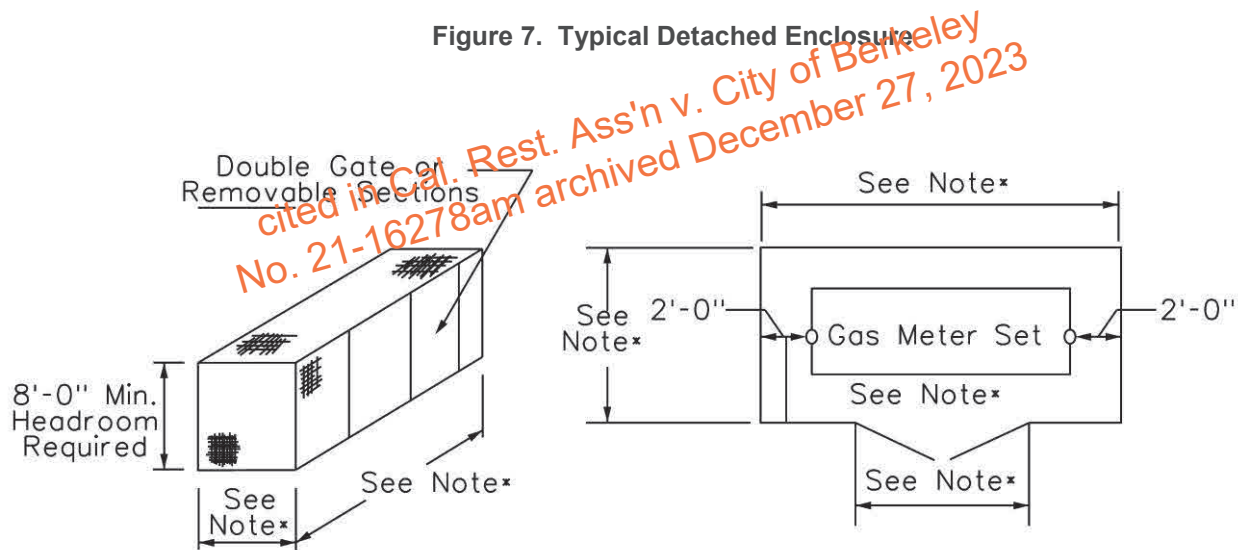
**J-15**

Publication Date: 08/18/2021 Effective Date: 11/01/2021 Rev. 9a

3.B. (continued)



**Figure 7. Typical Detached Enclosure**



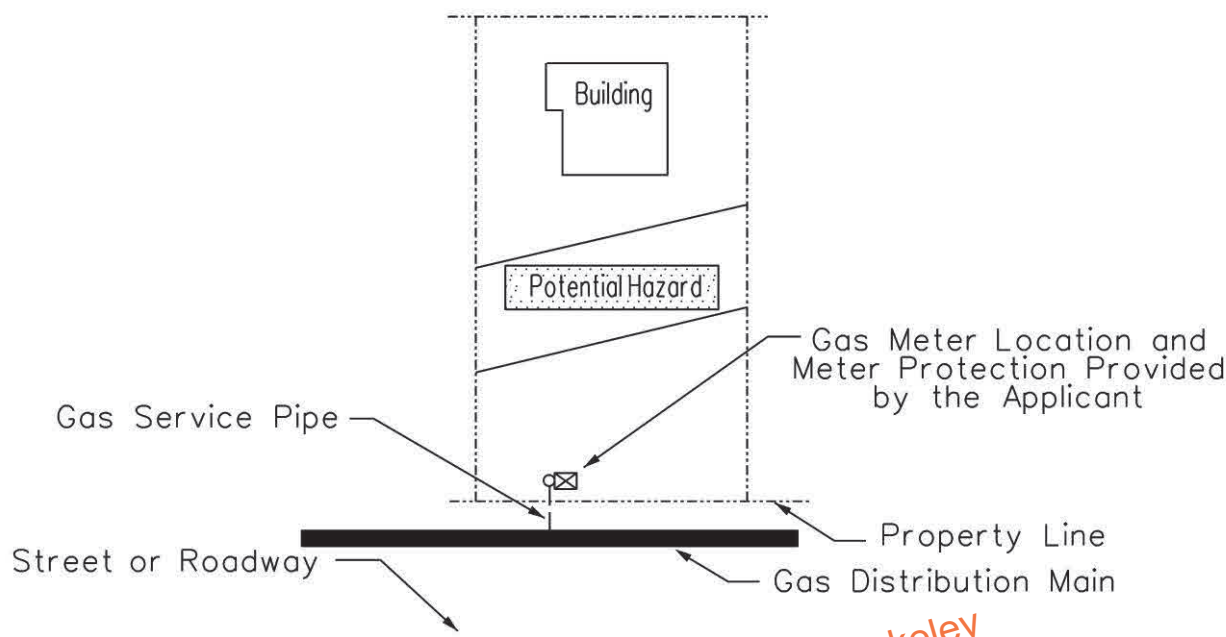
\* The enclosure's width and length will vary depending on the meter set. Contact your local PG&E project coordinators (formerly service planners) for more information.

**Figure 8. Typical Enclosure Dimensions**

**Gas Meter Locations****J-15**

Publication Date: 08/18/2021 Effective Date: 11/01/2021 Rev. 9a

3.B. (continued)

**Figure 9. Property Line Installation****C. Specific Requirements for Meter Sets Located in Alcoves**

- (1) An alcove's width can vary depending on the meter set. The height of the alcove is typically 8 feet; the depth must not exceed 36 inches. PG&E provides final dimensions after confirming the meter size and the number of meters.
- (2) A manifold located in an alcove may require a custom design depending on the configuration.
  - (a) For single-diaphragm meters, applicants must use the area dimensions shaded in [Figure 1](#) and [Figure 2](#).
  - (b) Single-rotary meters or multi-meter manifolds may require a custom design depending on the configuration.
  - (c) A gate is not a preferred option and requires approval on an exception basis. If a gate is proposed in front of the alcove, it must have at least 50% open area.
  - (d) No lighting, wirings, foreign pipes or other facilities are allowed in the alcove.

**Gas Meter Locations****J-15****Publication Date:** 08/18/2021 **Effective Date:** 11/01/2021 **Rev.** 9a

---

**D. Specific Requirements for Meter Sets Located in Breezeways****(1) Isolation from Living Spaces**

Meter sets installed in breezeways must be located so that gas cannot migrate into building openings.

**(2) Ventilation**

Meter sets may be installed in breezeways that are adequately ventilated to the outside atmosphere. The breezeway must be open at both sides.

**(3) Separation from Sources of Ignition**

No sources of ignition are allowed in the breezeway. Any electric wiring, switches, light fixtures, or circuit breakers must meet the requirements of the National Electric Code for installation in Class 1, Division 2 areas.

**E. Specific Requirements for Meter Sets Located in Cabinets or Gas Closets**

(1) Meter cabinets are not a preferred method of installation. A meter cabinet larger than for single domestic meter installations requires prior approval from the local field services manager. When approved, it must comply with the requirements in this section.

(2) It is preferred to have regulators installed on the outside of the cabinet. Additional space is required for larger regulators and dual-head regulators. Installing the regulators in a cabinet requires prior approval from the local field services manager. If there are regulators in a cabinet, then the vents must be piped out of the cabinet per GDS H-93, "Piping – Details, Regulator Vent Lines - Above Ground."

(3) Meter sets and meter set components located in a cabinet must have adequate working space, proper ventilation, and no source of ignition. See GDS K-51, "Single Meter Cabinet for Domestic Gas Meters," for single meter cabinet requirements and details. Final cabinet dimensions must be approved by Company prior to construction for other than single domestic meter size.

(4) Cabinets must be designed to be vapor-proof and prevent migration of gas into the interior of a building or other location where gas may create a hazard. The cabinet must be constructed of non-metallic and non-combustible material with non-metallic doors, and open to the outside.

(5) Meter cabinets that have been constructed prior to acceptance by Company may not be approved. Submitting these requests with the application early in the planning stage reduces delays.

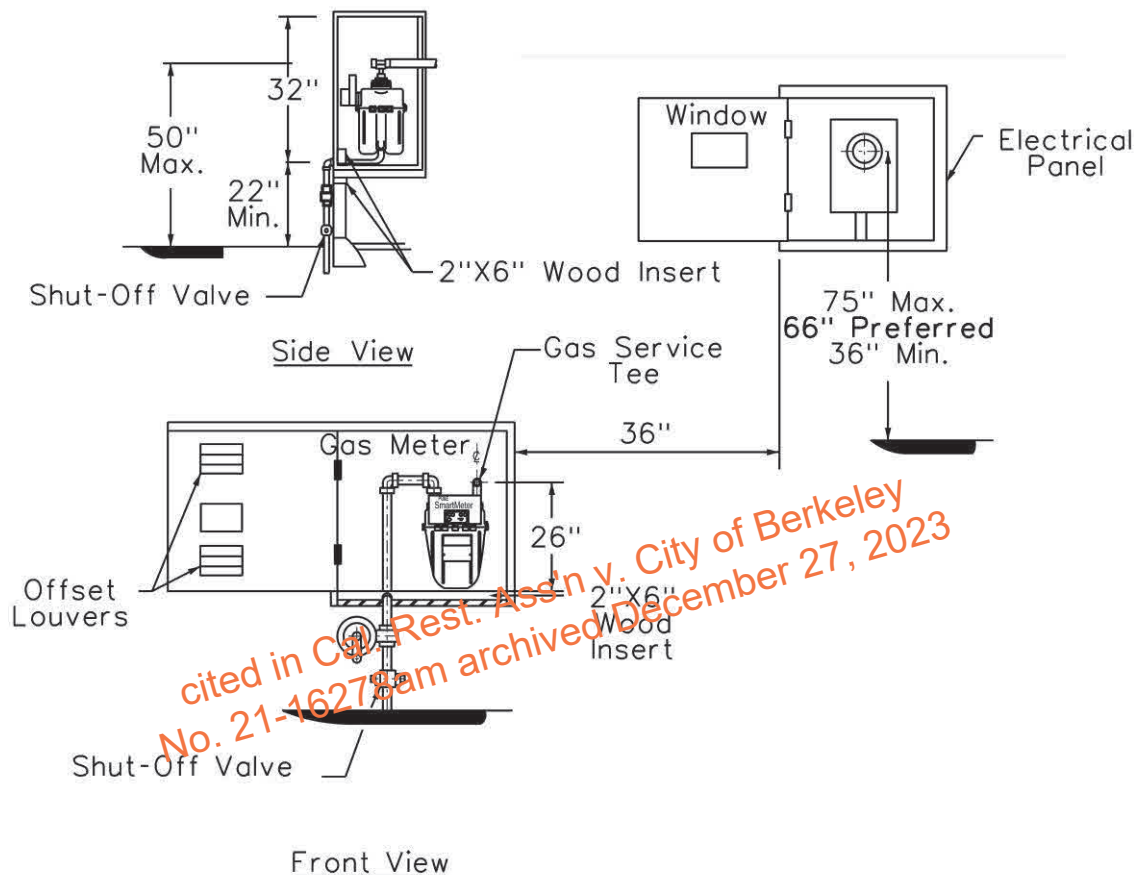
(6) Modifications to existing gas meter sets in cabinets must comply with current codes and standards.

**Gas Meter Locations****J-15**

Publication Date: 08/18/2021 Effective Date: 11/01/2021 Rev. 9a

3.E. (continued)

- (1) Cabinets are limited to a minimum depth of 18 inches and a maximum depth of 36 inches. See Figure 10, below, for specific meter cabinet sizes and clearances. Cabinets deeper than 36 inches must conform to the requirements of GDS J-16.



**Figure 10. Specifications for a Recessed Individual Meter Cabinet**

## (2) Gas Meter Closets

- (a) Gas meter closets must be furnished and installed by the applicant and have a depth of 18 inches minimum and 36 inches maximum, without exception. Doors must be non-metallic and fully louvered.
- (b) Doors must open at least 90° and have a clear opening height of 6 feet, 8 inches.
- (c) The inside of the closet must be made of non-flammable material and have a minimum 1-hour fire rating. All joints and penetrations must be sealed to prevent gas from migrating into the structure. Foreign pipes are not allowed inside the closet with the exception of fire sprinkler heads. Lighting, wiring, conduits, junction boxes, or inspection panels of any kind are not allowed inside the closet. Bonding or grounding wires on the customer's houelines are not allowed inside the closet.



**Gas Meter Locations****J-15**

Publication Date: 08/18/2021 Effective Date: 11/01/2021 Rev. 9a

## 3.E. (continued)

- (d) The ceiling must have a 1:12 slope. The ceiling must slope up toward the door frame with a maximum of 6 inches measured from the door opening to the finished ceiling.
- (e) The inside width of the closet cannot exceed 8 inches beyond either side of the door frame. Refer to Section 3.H, below, for manifold spacing to determine the size of closet required for the desired number of meters. The meters and manifold must fit within the opening of the closet doors with the exception of the tie-in piece from the outside riser.
- (f) The riser and regulator must be installed outside of the closet. The applicant provides a penetration through the wall into the closet. Contact your local project coordinator for the exact size and location of the required penetration.
- (g) The doors must have the identifying sign "Gas Meters." If the doors have locks, the applicant must install a lock box near the closet that is acceptable to PG&E and contains a key.
- (h) The closet cannot be used for storage of any kind. Only PG&E gas meters and metering appurtenances are allowed inside the closet.

## F. Specific Limitations for Curb Meter Sets

- (1) The Company considers curb meter installations undesirable because they are difficult to maintain. See GDS J-14.1, "Curb Meter Installations," for a description of the policy and design considerations for curb meter installations. Depending on the size and type of facilities, required equipment may not be available or suitable for use below grade.

## (2) Large Meter Installations for Commercial or Industrial Loads

On an exception basis, a vault or meter box may be located on the customer's property, either adjacent to the building served or near the property line.

## G. Specific Requirements for Meter Sets Located Inside Buildings

Meter sets and all meter set components located inside buildings must be contained within a dedicated gas meter room, as specified in GDS J-16.

## H. Multi-Meter Manifolds

Multiple meters will be at one approved location for each property or location. Number of meters, tiers and size of piping are designed by the Company. See GDS J-52.1, "Gas Meter Manifolds (1-1/4" and 2" Sizes)," GDS J-52.2, "Brackets for Gas Meter Manifolds," and GDS J-52.3, "Gas Meter Manifolding." The Company limits gas meter manifold configurations to one-tier or two-tier meter manifolds not exceeding 60 inches high. These manifolds are measured from the final level standing surface to the top of the manifold. See [Figure 11](#) and [Table 1](#).

## Gas Meter Locations

J-15

Publication Date: 08/18/2021 Effective Date: 11/01/2021 Rev. 9a

3.H. (continued)

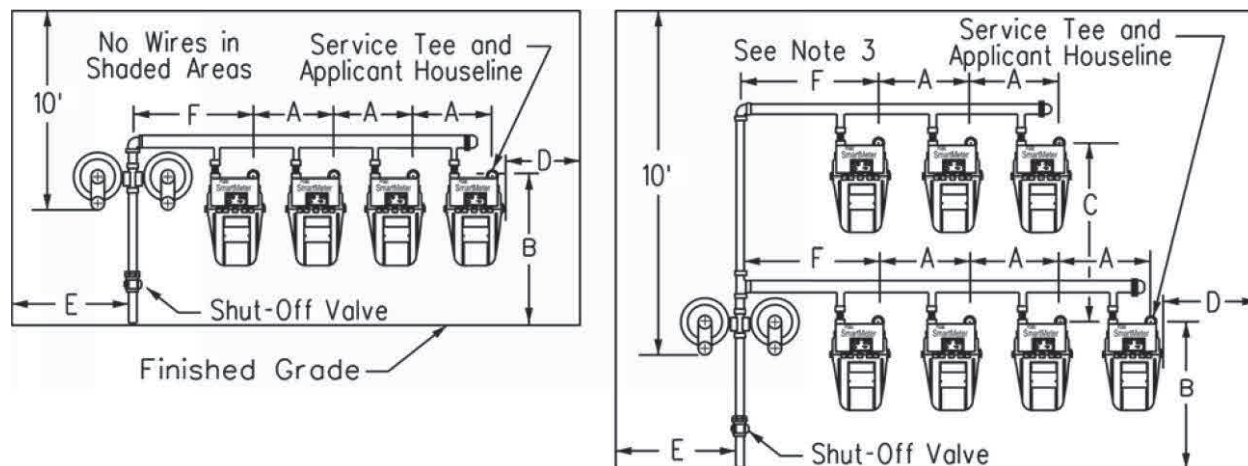


Figure 11. Typical Multimeter Installations

## Notes for Figure 11

1. The applicant's houselines must be stubbed out 4 inches to 6 inches from the finished wall at the locations shown.
2. The applicant must clearly mark each houseline.
3. Applicants must not install any electrical devices or equipment, including wires, cables, metering enclosures, telecommunication enclosures, bond wires, clamps, or ground rods within 36 inches horizontally from the farthest edge of PG&E facilities and 10 feet above the regulator vent.
4. Applicants may need to install the rise farther away from the building to accommodate the manifold installation. Consult your local project coordinator for site-specific details.

Table 1. Dimensions for Figure 11

Label in Fig. 11	Installation Dimensions	Comments
<b>A</b>	12" for residential only 15" for cabinet installations only 20" for all commercial meters up to 1000 class	PG&E provides custom-design dimensions for mixed meter sizes and for meters larger than 1000 class.
<b>B</b>	26" (typical) for unenclosed 32" (typical) for cabinet installations	-
<b>C</b>	24" residential (unenclosed and cabinet) 36" commercial	Contact local project coordinator for two-tier commercial manifolds.
<b>D</b>	6" min. to inside building corner 12" min. to outside building corner 36" to electrical wired (see Note 3)	From farthest edge of PG&E equipment.
<b>E</b>	30" min. to inside or outside corner of building 36" min. to electrical wires (see Note 3)	PG&E may approve reduction of Dimension E on a case-by-case basis – e.g., in non-pedestrian traffic areas, or on select PG&E equipment.
<b>F</b>	24" (typical) for residential 36" (typical) for 400 to 1000 class meter, commercial	PG&E provides custom-design dimensions for mixed meter sizes and for larger than 1000 class meters.

**Gas Meter Locations****J-15****Publication Date:** 08/18/2021 **Effective Date:** 11/01/2021 **Rev.** 9a

---

## 3.H. (continued)

**Note:** The Company does not install meters unless the permanent address, the location, or the area being served (if applicable) is marked at each meter location.

- I. The Company requires that buildings, dwellings, occupancies, houselines, or other facilities or locations be marked to identify gas lines that are serving locations or supplying equipment. Applicants must ensure that the following rules for marking houselines are enforced.
  - (1) The Company requires that lines be marked by attaching an embossed, durable, metal or plastic tag to each houseline. The Company must approve of the tag.
  - (2) Markings must be legible and specific.
  - (3) Marking information must include an authorized apartment or street number and a use or location designation.
  - (4) The houseline must be permanently, clearly, and prominently marked at the point of the service connection (i.e., service delivery point).

## J. Protecting Meter Sets From Vehicular Damage

- (1) Meter Sets in Traveled Areas

If any portion of a gas meter set must be located in or adjacent to traveled areas where there is the probability of vehicular damage, physical protection acceptable to the Company must be provided by the customer. The Company determines when such protection is required. Physical protection must be provided for any gas meter, per GDS J-95.

- (2) Returning Damaged Meter Sets to Service

If a meter set is damaged by a vehicle or other equipment and there is a potential for a recurrence, temporary barricading must be installed before service is restored, and until permanent protection is installed, per GDS J-95, or the meter is relocated.

**Gas Meter Locations****J-15**

Publication Date: 08/18/2021 Effective Date: 11/01/2021 Rev. 9a

**Target Audience**

Personnel who work in design, engineering, estimating, field services, maintenance and construction (M&C), gas pipeline operations and maintenance (GPOM), and general construction.

**Definitions**

Alcove	Exterior space that is recessed into a building. The alcove's width can vary depending on the meter set. PG&E provides final dimensions after confirming the meter size.
Breezeway	A passage or walkway with full openings on both sides. No sources of ignition or openings into the building.
Cabinet	A structure, not deeper than 36 inches, with a solid or closed top that is freestanding, attached or recessed into a building exterior wall, vapor proof from the building, with access doors for the purpose of containing/protecting a gas meter set or meter set components.
Enclosure	A structure with an open top that is freestanding or attached to a building exterior wall with access doors; a cage; or walls and gate for the purpose of containing/protecting a gas meter set or meter set components.
Gas meter room	A space within a building that is solely used to house natural gas metering equipment in accordance with GDS J-16, "Gas Meter Room."
Meter set	The gas meter, service regulator, overpressure protection devices, and all associated Company piping and fittings between the service riser valve and the customer houseline.
Readily accessible location	<p><i>For a gas meter set:</i> The preferred location can be accessed immediately and does not require contact with the owner or occupant. If the preferred location is unavailable, the Company may approve a lock box with key for access.</p> <p><i>For a service shut-off valve:</i> The preferred location is outside and aboveground. If the preferred location is unavailable, the Company may approve a curb valve in which no permanent structure prevents immediate valve access or operation.</p>
Show window	A ground floor window in the wall of a commercial building, including any permanent elevated display floors or platforms associated with the window, where the purpose of the window is to present a display to the public.
Source of ignition	As defined by the National Fuel Gas Code Handbook, sources of ignition are defined as "devices or equipment that, because of their intended modes of use or operation, are capable of providing sufficient thermal energy to ignite flammable gas-air mixtures." This includes electric wiring, switches, and circuit breakers that do not meet the requirements of the National Electric Code for installation in Class 1, Division 2 areas.

**Gas Meter Locations****J-15**Publication Date: 08/18/2021 Effective Date: 11/01/2021 Rev. 9a

---

**Acronyms and Abbreviations**

CFR: Code of Federal Regulations  
CPUC: California Public Utilities Commission

**Compliance Requirement/Regulatory Commitment**

Code of Federal Regulations (CFR) Title 49, Transportation, Part 192—Transportation of Natural and Other Gas by Pipeline: Minimum Federal Safety Standards, Section (§) 192.353, “Customer meters and regulators: Location”

CFR 49 § 192.355, “Customer meters and regulators: Protection from damage”

CFR 49 § 192.357, “Customer meters and regulators: Installation”

CFR 49 § 192.363, “Service lines: Valve requirements”

CFR 49 § 192.365, “Service lines: Location of valves”

**Records and Information Management:**

Information or records generated by this design standard must be managed in accordance with the Enterprise Records and Information (ERIM) Policy, Standards and Enterprise Records Retention Schedule (ERRS). Refer to GOV-71045, “Enterprise Records and Information Management Standard,” and related standards. Management of records includes, but is not limited to:

- Integrity
- Storage
- Retention and Disposition
- Classification and Protection

**References**

California Public Utilities Commission (CPUC) General Order 112-F, “State of California Rules Governing Design, Construction, Testing, Operation, and Maintenance of Gas Gathering, Transmission, and Distribution Piping Systems”

Gas Design Standard (GDS) A-75, “Gas Service and Mains in Plastic Casing”

GDS A-90, “Polyethylene Gas Distribution System Design”

GDS H-15, “Design Requirements for Company-Owned Gas Regulating Systems Serving Customers”

GDS H-91, “Vent Cover for Regulator on Curb Meter Sets”

GDS H-92, “Plastic Vent Caps”

GDS H-93, “Piping – Details, Regulator Vent Lines - Above Ground”

**Gas Meter Locations****J-15**Publication Date: 08/18/2021 Effective Date: 11/01/2021 Rev. 9a

---

## References (continued)

GDS J-14.1, "Curb Meter Installations"

GDS J-16, "Gas Meter Room"

GDS J-52.1, "Gas Meter Manifolds (1-1/4" and 2" Sizes)"

GDS J-52.2, "Brackets for Gas Meter Manifolds"

GDS J-52.3, "Gas Meter Manifolding"

GDS J-95, "Meter Guard Design and Installation Arrangement"

GDS K-10, "Precast Concrete Pit"

GDS K-10.1, "Precast Concrete Vaults &amp; Pits"

GDS K-40, "Plastic Valve Box for 3/4" – 4" Valves"

GDS K-40.1, "Method of Installing Concrete Curb Boxes in Concrete Sidewalk"

GDS K-42, "Precast Boxes 24" x 36", 30" x 48", and 30" x 60"

GDS K-42.1, "Precast Boxes 13" x 24" and 17" x 30"

GDS K-51, "Single Meter Cabinet for Domestic Gas Meters"

Gas Rule 16, "Gas Service Extensions"

NFPA 70: National Electric Code (NEC)

Utility Manual TD-7001M, *Electric and Gas Service Requirements* (Greenbook), Section 2, "Gas Service"

Utility Standard S4446, "Vault Inspection Procedure"

**Appendices**

NA

**Attachments**

NA

## Gas Meter Locations

J-15

Publication Date: 08/18/2021 Effective Date: 11/01/2021 Rev. 9a

---

### Revision Notes

Revision 9a has the following changes:

1. In 3.A.(13).(a), removed requirement to install a protective sleeve or “sunshield.”

Revision 9 (Publication Date: 11/15/2017 Effective Date: 11/29/2017) has the following changes:

2. Updated Purpose and Scope.
3. Updated Applicability.
4. Updated Definitions.
5. Added figures from Electric and Gas Service Requirements (Greenbook).
6. Added language requiring meter sets in cabinets to be approved by Field Services Manager.

**Asset Type:** Customer Connected Equipment

**Function:** Design and Construction

**Document Contact:** [Gas Design Standard Responsibility List](#)

*cited in Cal. Rest. Ass'n v. City of Berkeley  
No. 21-16278am archived December 27, 2023*



## GAS DESIGN STANDARD GAS METER ROOM

J-16

Publication Date: 10-09-13 Rev. #03a

### Purpose and Scope

This gas design standard describes the requirements for any gas meter room inside any building. Local jurisdictions may have adopted codes or ordinances relating to customer-owned and maintained facilities that could require consideration when designing a gas meter room. Compliance with California Public Utilities Commission (CPUC) requirements is mandatory. For PG&E gas meter locations, the applicable codes and regulations are described in [Gas Design Standard J-15, "Gas Meter Locations."](#)

### General Information

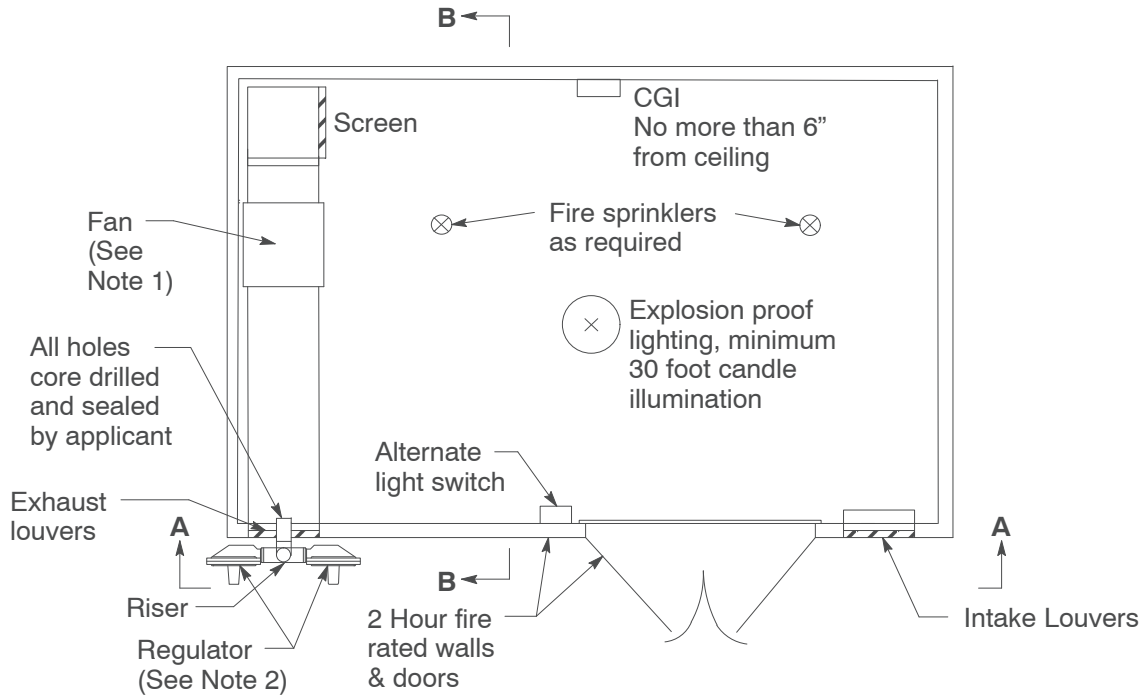
1. A gas meter room is a space within a building that is solely used to house natural gas metering equipment.
2. **The preferred gas riser, meter and regulator location is outside and adjacent to the building being served.** On an exception basis, gas meters and regulators may be installed in a specially designed gas meter room. However, PG&E will not install a gas meter in a gas meter room unless all of the following conditions have been met:
  - A. The applicant has specifically applied to install the gas meter in a specially designed room.
  - B. The applicant's request is accompanied by an explanation detailing the reasons why the presence of some condition associated with the property itself makes it impossible to locate the gas riser, regulator and meter outside the building OR that such location would deny the applicant a substantial benefit of property ownership enjoyed by other similarly-situated properties and that the approval of this exception would not constitute a special privilege to this applicant which has been denied to similar applicants in other locations.
  - C. PG&E must concur that the unique attributes of this property render it impossible to locate the riser, regulator and meter outside the building and that approval of the proposed meter room is reasonable and safe and does not constitute a grant of a special privilege or advantage.
  - D. PG&E and the applicable planning/building department must approve the design in advance of any construction.
  - E. The applicant has recorded a covenant substantially in the Covenant Agreement which provides that the applicant or its successors in interest will maintain the meter room as approved by PG&E in good and serviceable condition, will provide access to PG&E or its agents at all times, and will not use the meter room for any other purpose (e.g. storage).
3. A meter room may not be used as a storage area.
4. It is the responsibility of the applicant to design, construct, and furnish the gas meter room and related materials to meet the gas meter room requirements that are described in this document, and in accordance with the California Building Code, including means of egress and those provisions to safeguard the health and safety of all personnel. The minimum room dimensions will be unique for each project based on the meter, regulator, and manifold requirements necessary to serve each load. Applicant gas service and meter installation arrangements are subject to PG&E's review and approval.
5. A covenant must be placed on the deed of property ensuring that successive property owners will adhere to the requirements in this standard. The covenant will be prepared by the PG&E land department and recorded on the deed of property prior to the installation of the gas meters. The covenant will state that PG&E has the right to suspend or terminate gas service if the conditions of this standard are not upheld. In addition, the covenant will state the owner is responsible for complying with gas tariffs. Any deviation in the form of the Covenant Agreement must be approved by the PG&E land department prior to installing of the gas meters.
6. The covenant confirms the applicant's financial responsibility when a relocation of PG&E facilities is required; e.g. relocating a meter set from a basement under the city sidewalk.



7. The covenant will provide that PG&E has the right to terminate service if ever PG&E determines, through regular inspection, information or otherwise that the terms of this standard have not been upheld. The following list describes examples of some but not all situations that violate the terms of this standard:
  - A. The fan is not in constant operation or does not turn on with the lights.
  - B. The lights are not operational.
  - C. The combustible gas indicator (CGI) is not signed-off or up-to-date.
  - D. The room is not vapor-tight.
  - E. The room is not clear of storage.
8. Gas meter room location and piping must conform to all current federal, state, and local codes including [Code of Federal Regulations 49 \(CFR. Part 192\)](#), "[Transportation of Natural and Other Gas by Pipeline: Minimum Federal Safety Standards.](#)" and the National Fuel Gas Code (NFPA 54).
9. PG&E requires all applicant installed electrical equipment in the room be classified as Class I, Division 1, Group D pursuant to NFPA-70, National Electric Code.
10. Do not locate or place any electric devices or electrical connections for services such as cable television or telecommunications within the gas meter room. Under no circumstances will this requirement be waved.
11. All electrical wiring and conduit that pass through a gas meter room must conform to the National Electric Code Article 501.
12. The customer must provide lighting for the gas meter room, with a minimum 30 foot-candle illumination.
13. No foreign pipe (i.e., drain lines, domestic water, etc.) or ducts are permitted to be located in or routed through the gas meter room.
14. Gas meter room(s) must be designed to prevent entrapment of gas. Mechanical ventilation to the outside atmosphere is required.
15. The requirements of this standard must be met when a customer houseline is added to an existing gas meter room or gas meter set within a building.

#### General Service Requirements

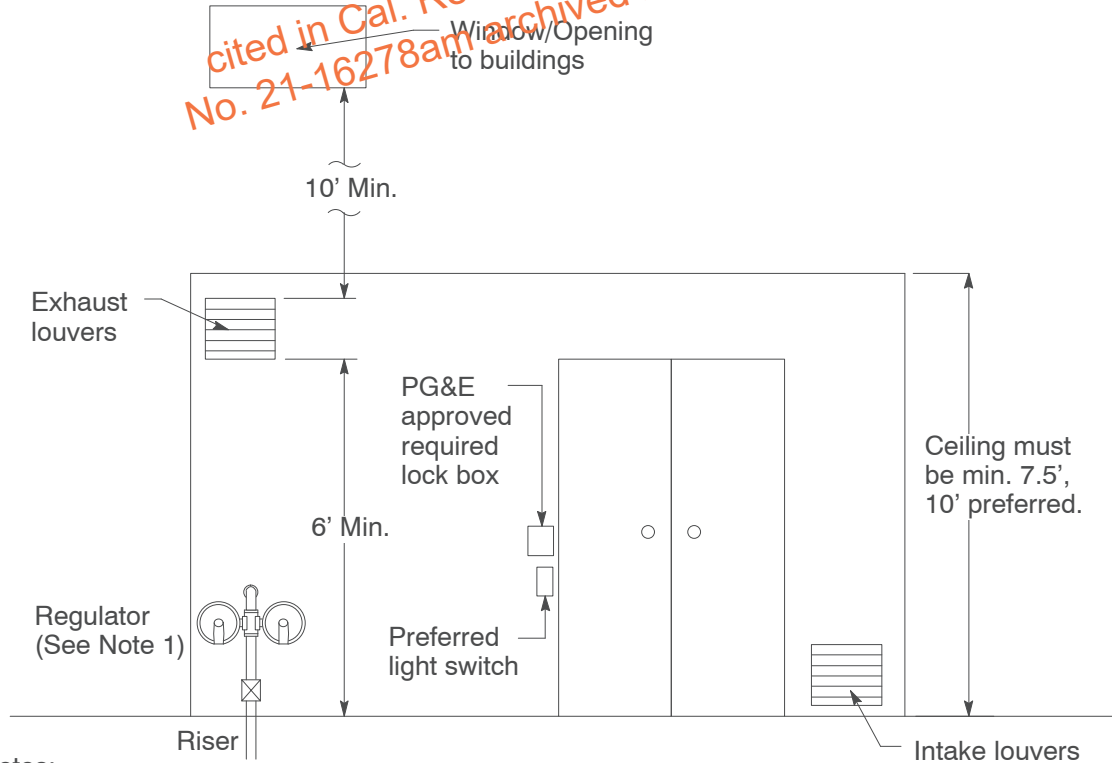
1. Service shut-off valves must be installed and comply with the following:
  - A. Each new service or replacement service must have a readily accessible shut-off valve that is preferably located outside, above ground on the gas service riser.
  - B. If it is necessary to locate the riser inside a building, or an existing riser valve is otherwise inaccessible, then a curb shut-off valve must be installed at the customer's expense in a readily accessible location in accordance with [Gas Design Standard A-43.2, "Curb Valve Installations, Distribution Systems."](#)
2. Service Riser Locations
  - A. Service risers must not be installed inside buildings or meter rooms, except where special circumstances prevent outside installation. The installation of an inside riser may be justified at the discretion of the local PG&E senior gas engineer. PG&E must grant prior approval for any gas meter design/location where settlement or subsidence issues have been identified in any geotechnical report.
  - B. Examples of situations where inside risers are considered:
    - (1) A location with insufficient clearance between the building and the property line to safely locate the riser outside of the building.
    - (2) A building with the meter room located inside of a basement or half basement, where an outside riser at ground level would enter the room at an excessive height.
    - (3) An inner city urban redevelopment building with inadequate space for an outside riser.
    - (4) A designated historical building where modifications needed to locate the riser outside are not permitted.
    - (5) Sidewalk Basements - when the service passes through a sidewalk basement to the meter location on private property. Sidewalk basements are basement spaces built underneath a city sidewalk, in front of the foundation wall of a building. The PG&E land department must review and verify the applicant has sufficient rights for PG&E equipment to be in a sidewalk basement prior to the installation of the gas meters.
  - C. Existing service risers inside of buildings or meter rooms may be repaired with a plastic insert in accordance with [Gas Design Standard A-90, "Plastic Main and Service Installation."](#)



Notes:

1. Fan can be mounted anywhere in the exhaust duct.
2. Regulator vents to be piped outside when regulators are approved to be installed inside room.

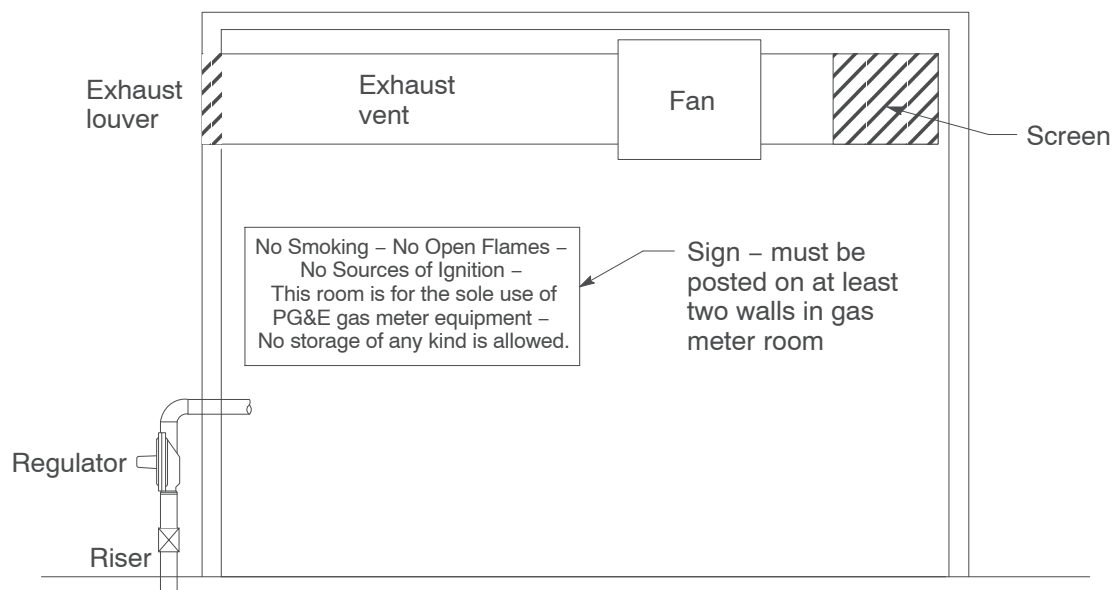
Figure 1  
Plan View



Notes:

1. See Natural Gas Regulator Requirements 3.A.(1), Page 6.

Figure 2  
Front Outside Elevation - A



**Figure 3**  
**Cross Section - B**

### Meter Room Location Requirements

The following is a list of gas meter room locations that will be approved by PG&E for situations where the customer's building occupies all of the property that is owned by the customer (i.e., zero lot line) and the construction of an alcove is not possible. Option 1 is preferred and successive options will only be considered when the previous options are not possible:

1. A meter room that is accessible from a public right-of-way at all times. The gas meter room is located at an above grade location designed and constructed with walls, ceiling, and floor that are vapor-tight to prevent the migration of gas to the building's interior. The gas meter room has doors that open to the outside of the building.
2. A gas meter room that is located adjacent to an outside building wall inside the customer's building and constructed with walls, ceiling, and floor that are vapor-tight to prevent the migration of gas to the building's interior. This gas meter room is also located at grade level with a door that opens to the inside of the building. These doors shall be vapor-tight to prevent the migration of gas to the building's interior.
3. A customer's building's basement meter room that is adjacent to an outside wall and constructed with walls, ceiling, and floor that are vapor-tight to prevent the migration of gas to the building's interior.
4. A sidewalk basement meter room is not acceptable without a written approval from the municipality and PG&E.

### Natural Gas Meter Room Design Requirements

1. Fire rated walls must have a minimum 2-hour fire rating, or as specified in the California Building Code for Group H, Division 1 occupancies.
2. All entry and exit doors must be rated commensurate with the rating of the wall. Doors that open to the inside of the building must be vapor-tight to prevent the migration of gas to the building's interior.
3. The applicant/customer must consult with local PG&E service planning personnel to obtain the required gas meter room dimensions. Door dimensions and access must be approved by PG&E on a case-by-case basis.
4. No floor drains are permitted within a natural gas meter room.
5. If the applicant/customer's building is equipped with a fire sprinkler system pursuant to NFPA-13 standard for the installation of sprinkler system, the applicant/customer must also install fire sprinklers inside of the gas meter room.
6. Only explosion-proof lighting fixtures are to be installed in a gas meter room and these must meet the requirements of the NFPA-70: National Electric Code for Class I, Division 1, Group D locations.

7. It is preferred to mount the light switch outside the room next to the entry door. Explosion-proof light switches must be installed if such switches are to be located inside of the meter room. These switches must meet the requirements of the NFPA-70: National Electric Code for Class I, Division 1, Group D locations.
8. No electrical receptacles (i.e., outlets) are permitted within a gas meter room.
9. The applicant/customer must furnish ladders or platforms inside of the gas meter room as required for a tiered meter configuration.
10. The floor-to-ceiling height inside of the meter room must be a minimum of 7.5 feet. The preferred height is not more than 10 feet.
11. Doors into gas meter rooms must be provided with approved signs. The signs must state that the room contains flammable gas.
12. Signs must be posted on at least two walls within the room stating "No Smoking – No Open Flames – No Sources of Ignition - This room is for the sole use of PG&E gas meter equipment – No storage of any kind is allowed".
13. A lock box, acceptable to PG&E, containing a door key to the gas meter room door must be installed by the applicant/customer and such lock boxes must be located near the gas meter room door.
14. The applicant/customer is responsible for core-drilling, sealing, waterproofing, and maintaining a vapor tight seal on any wall, ceiling, or floor where:
  - A. Inlet natural gas piping enters the building and/or the gas meter room.
  - B. Natural gas regulator relief vents exit the gas meter room and the applicant/customer's building.
  - C. Conduits containing wiring for the gas meter (and appurtenances) enter the gas meter room.

#### Gas Meter Room Ventilation Requirements

Applicant must submit the designs and calculations, stamped and signed by a licensed professional mechanical engineer, demonstrating that the ventilation for the gas meter room satisfies the following requirements:

1. Ventilation must be provided in accordance with the Mechanical Code and one of the following:
  - A. Continuous ventilation introducing fresh air at six air exchanges per hour.

**OR**

  - B. A combustible gas detection system, interlocked with an automatic ventilation system that will provide fresh air at six air exchanges per hour upon activation of the detection system. The gas detectors must be set at 20% Lower Explosive Limit (LEL) (or 1.0% concentration of natural gas in air). The instructions for the combustible gas detection system are found below in Requirements for Customer-Owned Equipment, Item 5.
  - The formula for the gas room air exchange calculation is:  

$$\text{minimum fan air flow rate (cfm)} = \text{room volume (cf)} \times 6 \text{ air changes per hour} / 60 \text{ minutes per hour}$$
 (where cfm = cubic feet per minute, cf = cubic feet.)  
**Pressure drop values (e.g. louver, screen and duct elements) must be included in the design and calculations.**
2. To ensure complete air exchange the low-fresh air intake and the high-exhaust air duct must be at opposite corners within the room. Exterior louvers must be in a low-fresh air and high-exhaust air configuration as far apart as practical and ensure no recirculation. The bottom of the high-exhaust air louver will be over the travel way at least 6' above the finish outside grade.
3. Mechanical fans and all other electric devices must be explosion proof and meet the requirements of the NFPA-70: National Electric Code for Class I, Division 1, Group D locations.
4. Mechanical fans and detection equipment must be continuously monitored in case of failure. Alarms for trouble and failure must be installed in accordance with NFPA-72, National Fire Alarm Code.

## Natural Gas Regulator Requirements

### 1. Natural Gas Regulators

Typically PG&E will install natural gas service regulators and overpressure protection devices outside of a meter room. Applicants/customers who want to install gas service regulators and overpressure protection devices inside of a meter room must provide PG&E with the written justification as part of the application. The preferred gas riser, meter and regulator location is outside and adjacent to the building being served. On an exception basis, gas meters and regulators may be installed in a specially designed gas meter room. PG&E must approve all gas meter and regulator installations and the gas meter room design in advance of any construction. If acceptable to PG&E, the following additional conditions apply:

- A. Each gas service regulator installed within a building must be located as near as practical to the point of the service line entrance into the meter room, and as specified by PG&E.
- B. PG&E will specify materials and designs for any overpressure protection devices needed, as outlined in Items 2 and 3 below.

### 2. Regulator Vent Lines

- A. Regulators and any additional overpressure protection equipment installed indoors must be vented to the outdoors. The customer is required to provide holes (penetrations) through walls or ceilings for these vents. In rare situations where the meter room location is not adjacent to an outside wall, the customer is required to install the vent piping from the meter room to the outside wall (PG&E will determine pipe size and location). PG&E will be responsible for connecting the vent piping to the regulator or overpressure protection device.
- B. PG&E will position gas regulators to minimize the length of the regulator vent lines and to ensure adequate venting capacity.
- C. PG&E will specify regulator vent lines, in accordance with [Gas Design Standard 1993, "Regulator Vent Lines – Above Ground."](#) when required.

### 3. Regulator Vent Locations

- A. Service regulator vents must terminate in a safe outside location that complies with the following criteria:
  - (1) The regulator vent must not terminate near any sources of ignition or openings into the building. The regulator vent must be 36 inches horizontally from sources of ignition and openings into the building, and this clearance area will extend 10 feet above and 36 inches below the regulator vent termination.
  - (2) A minimum lateral distance of 8 feet from a forced air intake. This includes the intake vents for the gas meter room.
  - (3) Within any location that is under display platforms or show windows in commercial buildings, including any permanent, elevated, display floors or platforms associated with the window.
  - (4) Within any location that is under building overhangs, where the overhang is likely to direct venting gas into a building opening.
- B. Vents for all natural gas regulator and gas monitor diaphragm equipment must terminate above a reasonable flood level. Regulator vent extensions must be separate lines, terminated so they are protected from the rain and provided with screened fittings to prevent insects and other debris from entering the vent.
- C. Vent locations must have final approval by PG&E.

## Requirements for PG&E-Owned Equipment

### 1. Natural Gas Metering

Electrical grounding or bonding to PG&E's metering facility piping or equipment or to customer-owned house lines inside of the meter room is not permitted.

### 2. Land-Line Cable and Conduit

Customers with an estimated average use of 10,000 therms per month or more are required to install, own, and maintain a nominal 1" diameter conduit and a telephone cable. PG&E's requirements for the conduit are described below.

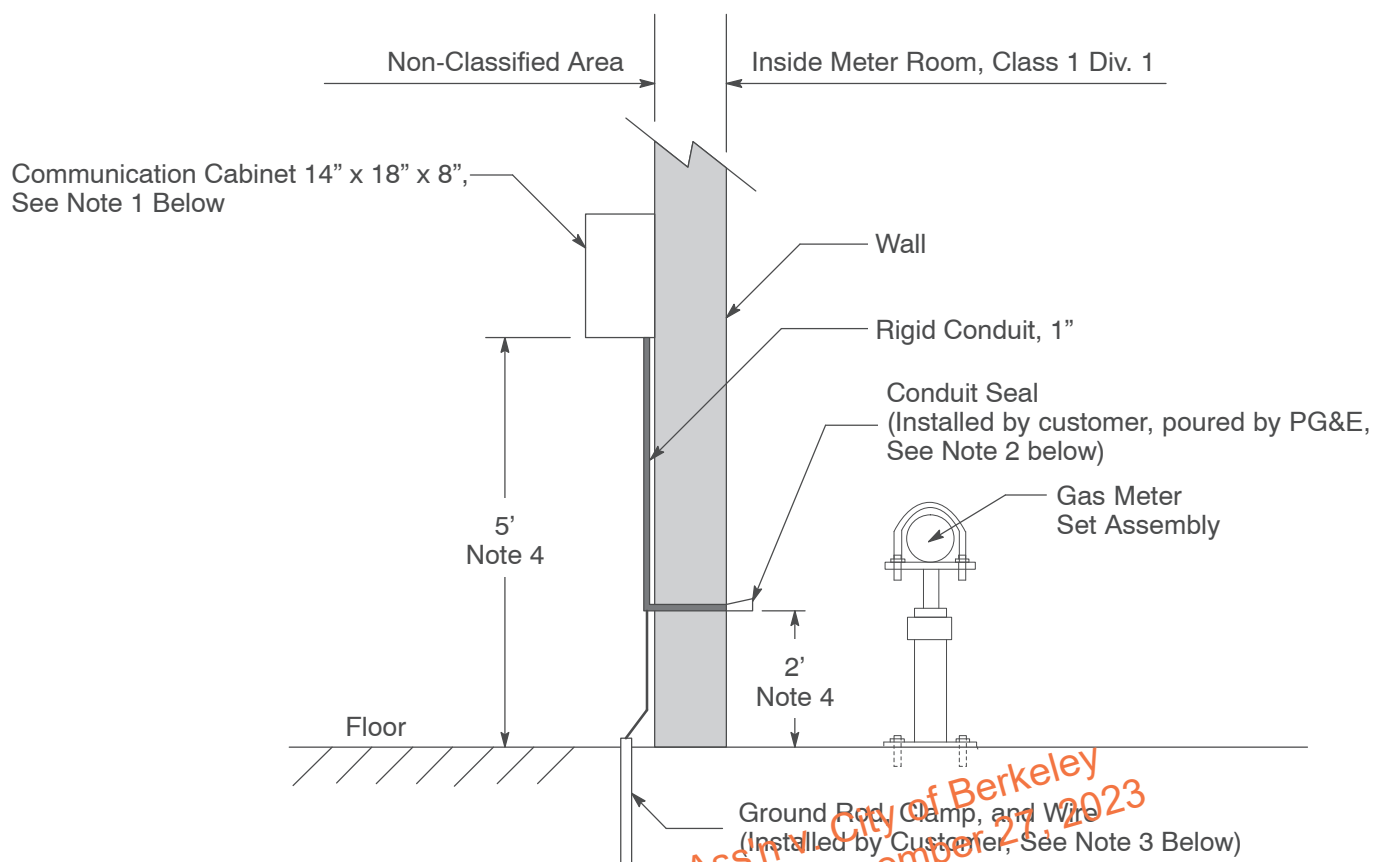
- A. Applicant/customer must extend the conduit and telephone cable from the closest telephone service location (i.e., outdoor "general purpose" area) to a location specified by PG&E that will be at or near the gas metering facilities. The maximum allowable distance from the telephone service location to PG&E's gas meter is 50 feet.
- B. Conduit must terminate within 3 feet of the gas meter location.
- C. Applicant must install a conduit seal, inside the gas meter room, within 18 inches of the boundary where the conduit enters the gas meter room. There must be no conduit fitting between the boundary and the seal. PG&E will pour the conduit seal.
- D. Applicant/customer is responsible for all charges and costs associated with installing the telephone facilities necessary to provide telephone service for PG&E's gas metering facilities which are to be used for PG&E's purposes.
- E. PG&E is responsible for establishing telephone service and for the ongoing telephone service charges for gas metering purposes.

### 3. Additional Equipment Needed to Support Gas Meters

Consideration must be given to the design requirements for:

- A. Volume pulse output connections.
- B. Electronic correctors.
- C. Power for gas meters. If AC power is required for PG&E equipment, the applicant must provide an outlet termination (with a lockable disconnect switch) located in the outdoor "general purpose" area, as noted in Item 2 above (also see Figure 4).

*cited in Cal. Rest. Ass'n v. City of Berkeley  
No. 21-16278 am archived December 27, 2023*



## Notes:

1. Cabinet must be large enough to accommodate outlet, AC/DC converter, EC modem, and customer pulse board.
2. Install conduit seal where conduit exits wall.
3. Ground rod with clamp must be 5/8" in diameter and 8' long. A #12 AWG insulated green ground wire connects ground rod to the communication cabinet.
4. Dimensions are for guidance only. Final design must be approved by PG&E.

**Figure 4**  
**Gas Meter Room**  
**Electric Enclosure and Conduit Arrangement**

#### 4. SmartMeter System

PG&E's SmartMeter Advanced Meter Reading system uses radio frequency technology to transmit meter reads automatically from the gas module. Applicants must make provisions for SmartMeter requirements to ensure that the SmartMeter Advanced Meter Reading system can operate properly. Consult with PG&E for current requirements.

Some, but not all, installation limitation requirements for SmartMeter gas module include:

- A. Module must be mounted at least 3" away from the wall in case of metal siding or foil insulation.
- B. Module must be installed with a spacer on surfaces other than plaster and wood.
- C. Module must be located at least 6" away from pipes, conduit, electrical wires, and other metal objects.
- D. Module must be located at least 4" vertically and 3" horizontally from other modules.
- E. Module must be located at least 2" below plaster or metal grid ceiling.
- F. Module, direct mount or remote, is installed above grade level.
- G. A remote module must be installed for any gas meter in a basement.

## Requirements for Customer-Owned Equipment

1. All customer-installed gas equipment must be installed downstream of the service delivery point. The service delivery point is defined as the gas supply point where PG&E's facilities connect to the customer houseline as follows:
  - A. For residential and small commercial meter sets, the service delivery point is the point where the male threads of the applicant's houseline connect to the female threads of PG&E's gas service tee fitting.
  - B. Because some commercial and industrial installations do not have service tees installed, the gas supply service delivery point is located at the first weld or fitting after the PG&E-installed bypass valve downstream of the meter.
2. Customer-installed equipment must not connect to utility facilities or obstruct the operation or serviceability of PG&E's piping, metering, and pressure regulating equipment. Customers are responsible for maintaining all customer facilities downstream of the service delivery point.
3. For multiple gas meter installations where the gas meters are supplied by means of a manifold, any installation of a customer automatic gas shut-off device must be installed downstream of the service delivery point for each meter.
4. Where customers elect to install an automatic shut-off device, all piping, valves, or other piping components must be installed downstream of (i.e., after) the gas supply delivery point.
5. When a combustible gas indicator (CGI) device and controller are installed, the following are required:
  - A. A gas sensor must be installed no more than 6" from the ceiling of the gas meter room.
  - B. The design and installation of all such detection devices and systems must be done in accordance with and comply with the NFPA-72, National Fire Alarm Code.
  - C. The controller must be installed outside of the gas meter room and be located near to the gas meter room door.
  - D. All wiring and piping of the transmitter to the controller must meet the requirements of NFPA-70, National Electric Code for Class I, Division 1, Group D locations.
  - E. An audible alarm and flashing strobe light must be included as a part of the controller system. This alarm system must continue to be operational until the condition that has triggered such an alarm has been determined and is manually reset.
  - F. The controller must have the capability to display readings of the percentage of the LEL readings from inside of the gas meter room.
  - G. The customer must maintain and calibrate the combustible gas indicator device and all related systems per the manufacturer's recommendations. An up to date inspection card will be mounted on the wall, just inside the door, signifying the gas detection device has been calibrated and is working accurately.
  - H. The light switch will continuously and fully engage the fan when turned on.

## Access to Meter Room

Applicant must make provisions to allow PG&E access to the gas meter room for emergency response, meter reading, system testing, inspection, and maintenance, in accordance with [Gas Rule 16, "Gas Service Extensions."](#)

## Records

1. Retain records per the Record Retention Schedule.



**Target Audience**

Design, engineering, estimating, field services, M&C crews, gas T&R, general construction

**Definitions**

NA

**Acronyms and Abbreviations**

AC: alternating current  
 AWG: American wire gauge  
 cfh: cubic feet per hour  
 CFR: *Code of Federal Regulations*  
 CPUC: California Public Utilities Commission  
 DC: direct current  
 EC: electronic corrector  
 EFV: excess flow valve  
 G.O.: CPUC General Order  
 LEL: lower explosive limit  
 NFPA: National Fire Protection Association

**Compliance Requirement/Regulatory Commitment**

NA

**References**

<a href="#">Curb Valve Installations, Distribution Systems</a>	A-43.2
<a href="#">Gas Service and Mains in Plastic Casing</a>	A-75
<a href="#">Plastic Main and Service Installation</a>	A-90
<a href="#">Prefabricated Risers</a>	A-91
<a href="#">Design Requirements for Company-Owned Gas Regulating Systems Serving Customers</a>	H-15
<a href="#">Regulator Vent Lines – Above Ground</a>	H-93
<a href="#">Gas Meter Locations</a>	J-15
<a href="#">Meter Guard Design and Installation Arrangement</a>	J-95
<a href="#">Precast Concrete Vaults &amp; Pits</a>	K-10.1
<a href="#">Precast Boxes 24" x 36", 30" x 48", and 30" x 60"</a>	K-42
<a href="#">Single Meter Enclosure for Domestic Gas Meters</a>	K-51
<a href="#">Corrosion Control of Gas Facilities</a>	O-16
<a href="#">Vault Inspection Procedure</a>	S4446
<a href="#">Gas Service Extensions</a>	Gas Rule 16
<a href="#">Electric and Gas Service Requirements (Greenbook), Gas Service</a>	Section 2
<a href="#">Code of Federal Regulations, Transportation of Natural Gas</a>	49 CFR 192
<a href="#">CPUC General Order 112-E, Latest Edition</a>	G.O. 112-E
<a href="#">California Code of Regulations</a>	Title 24 CCR2, 4, 9,
<a href="#">National Fire Protection Association</a>	NFPA-13, 54, 70, 72, 497

**Appendices**

NA

**Attachments**

NA

**Revision Notes**

Revision 03a has the following changes:

1. Added section "Records."

Revision 03 has the following changes:

1. Item 15 added to General Information.
2. Added Figures 1, 2, and 3.
3. Item 10 of Natural Gas Meter Room Design Requirements, removed "maximum of 10 feet" high ceiling and revised to say "the preferred height is not more than 10 feet".
4. This document is part of Change 66.

**Asset Type:** Gas Transmission and Distribution

**Function:** Design

**Document Contact:** [Gas Design Standard Responsibility List](#)

*cited in Cal. Rest. Ass'n v. City of Berkeley  
No. 21-16278am archived December 27, 2023*

cited in Cal. Rest. Ass'n v. City of Berkeley  
No. 21-16278am archived December 27, 2023

**GAS DESIGN STANDARD  
VOLUME PULSE OUTPUT CONNECTION FOR GAS METERS****J-65.1****Publication Date:** 10-01-13 **Rev. #04****Purpose and Scope**

This gas design standard describes the typical installation of a volume pulser on a gas meter to provide the customer with a volume pulse output under the terms of the Electric and Gas Monitoring Meter Pulse Agreement, [Form 79-1049, "Agreement to Install Applicant Requested Common Special Facilities - Gas and Electric Rule 2."](#) Contact advanced metering service and support personnel for any volume pulser request and the latest copy of the pulse agreement form.

**General Information**

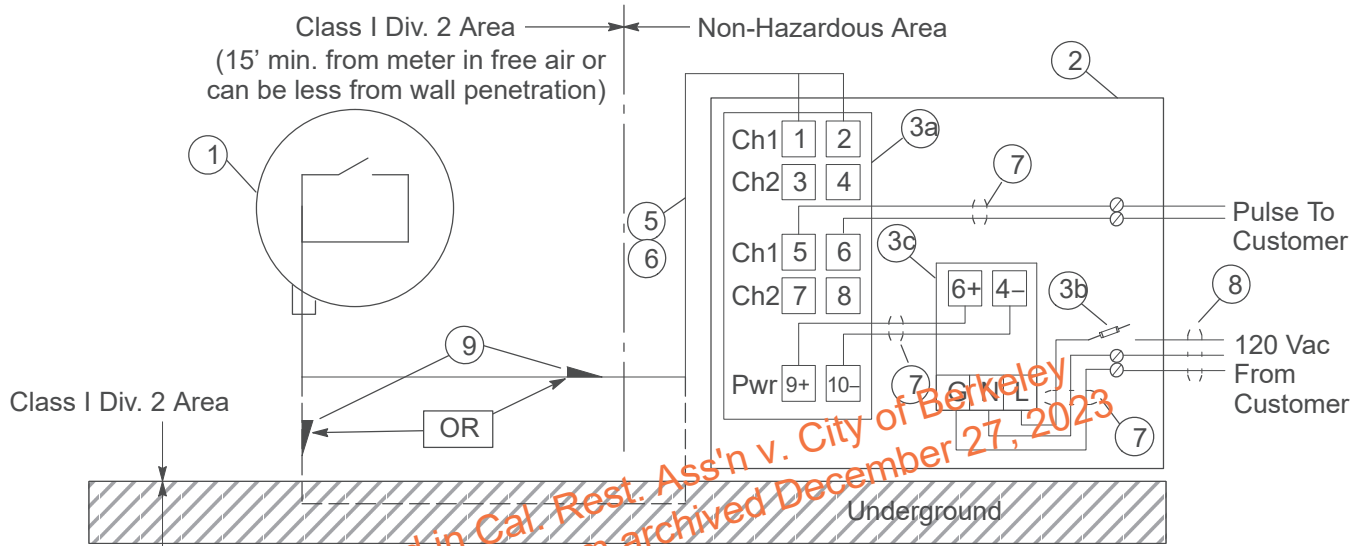
1. Pulsers installed or with connections within a 15' area of the meter-set flanges, valves, and threaded fittings must conform to NEC Class I, Division 2, Group D hazardous area requirements. Conduits must be sealed to prevent gas migration to areas classified as non-hazardous. For the purpose of this document, underground is considered non-hazardous.
2. All wiring between equipment must be in threaded rigid steel or intermediate steel conduit. Where provisions must be made for limited flexibility, liquid-tight flexible metal conduit in lengths not exceeding 3' may be used without securing or supporting the flexible conduit between termination points.
3. For a volume pulse output from an electronic corrector, see [Gas Design Standard J-65.2, "Volume Pulse Output Connection for Mercury Electronic Correctors."](#)

**PG&E Responsibilities**

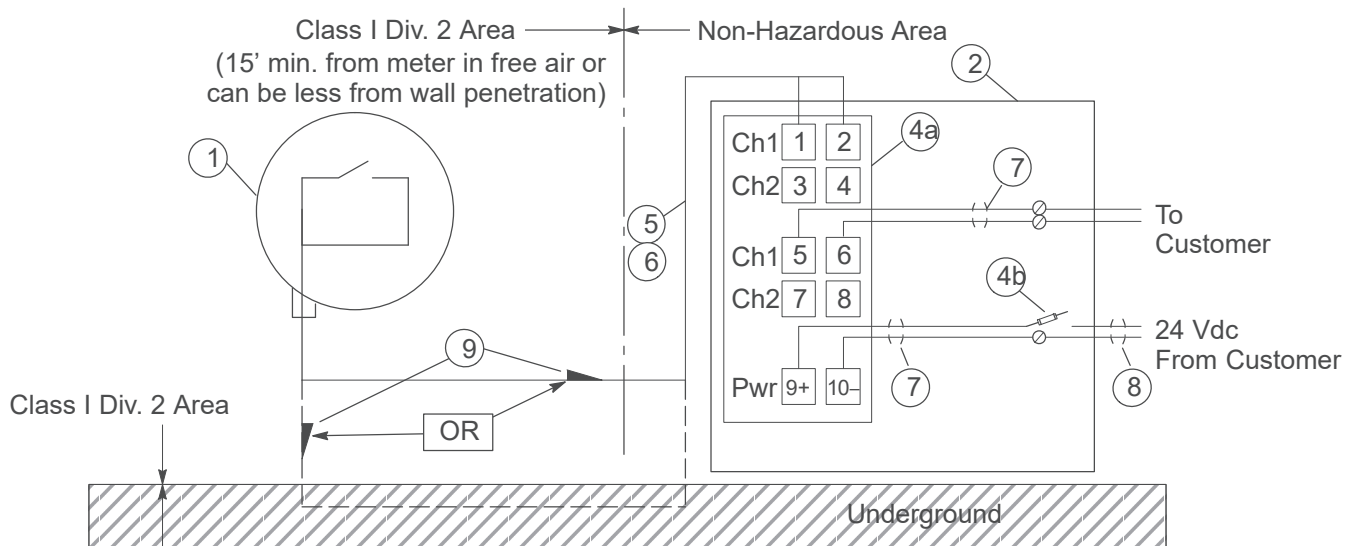
1. Provide intrinsic safety barrier enclosure to customer ("PG&E Responsibilities," Item 2). (Note: Customer must install the enclosure in the non-hazardous area, at least 15' but no more than 500' away from the gas meter set).
2. Install intrinsic safety barrier Item 3 for 120 Vac or Item 4 for 24 Vdc.
3. Provide and install pulser ("PG&E Responsibilities," Item 1).
4. Connect power wires provided by customer.
5. Connect pulser to intrinsic safety barrier.
6. Connect customer pulse output to intrinsic safety barrier.
7. Check for pulse connection.
8. Complete end-to-end test of the system.
9. Pour conduit seal after successful completion of end-to-end test.

**Customer Responsibilities**

1. Install enclosure (Table 1, Item 2) in the non-hazardous area, at least 15' but no more than 500' from the gas meter.
2. Install all conduit and wire (Table 1, Items 5 & 6) from intrinsic safety barrier enclosure to no farther than 3' from the gas meter and to customer power source. Leave extra 5' of wire at meter end and an extra 2' of wire at enclosure. (Note: Customer must not make any connections to the intrinsic safety barrier).
3. Install a conduit seal (Table 1, Item 9) on wall or out of ground if conduit is buried as close to the hazardous area transition zone as practicable.
4. Supply 24 Vdc power for intrinsic safety barrier. Alternatively, customer can supply 120 Vac. Provide PG&E with information on which type of power (120 Vac or 24 Vdc) must be provided.



**Figure 1**  
**Volume Pulse Output Connection (120 Vac Power)**



**Figure 2**  
**Volume Pulse Output Connection (24 Vdc Power)**

## Volume Pulse Output Connection for Gas Meters

J-65.1

Rev. #04 10-01-13

**Table 1 Bill of Materials**

Item	Quantity by Customer	Quantity by PG&E	Description
1	–	1	Pulser Specified in Table 2
2	–	1	Intrinsic Safety Barrier Enclosure - Hoffman QLINE E, Type 4X, Model Q251815ABE with Mounting kit QEMFK (installed by customer)
3	–	1	Intrinsic Safety Barrier system (120 Vac version) consisting of: a) Intrinsic Safety Barrier - 2-Chanel, 24 Vdc, Pepperl+Fuchs KCD2-SR-EX2 or equal b) Fused Power Disconnect. Phoenix UK 5 - HESI with 3 amp fuse c) Power Supply - 120Vac/24Vdc, Mean Well DR-4524
4	–	1	Intrinsic Safety Barrier system (24 Vdc version) consisting of: a) Intrinsic Safety Barrier - 2-Chanel, 24 Vdc, Pepperl+Fuchs KCD2-SR-EX2 or equal b) Fused Power Disconnect - Phoenix - UK 5 - HESI with 3 amp fuse.
5	1	–	Conduit, 1/2" Rigid, and 1/2" Liquid-Tite Metallic Flex (as required)
6	1	–	Three-Conductor Shielded Cable <sup>1</sup> , Stranded #22 AWG, Belden 9363, or Equal (for signal wiring)
7	–	1	Single Conductor #18 AWG for power wiring within enclosure
8	1	–	Single Conductor #12 AWG max for power wiring from customer power source (Note: Wire size used must be based on customer breaker size providing the power to enclosure)
9	1	–	Conduit Seal, EYS 1/2", Crouse-Hinds

<sup>1</sup> NEC Type PLTC per Article 725, which is approved for wiring in Class I Division 2 hazardous areas.

**Table 2 Volume Pulsers for Gas Meters**

Pulser Make and Model	Gas Meter Make	Gas Meter Model
American RVP-FI <sup>1</sup>	American Diaphragm Meters	AC 175, AC 250, AL 175, AL 310, AL 425, AT 175, AT 210, AT 250
	Rockwell Diaphragm Meters	175, 175S, 250, R275, 310, R315, 415
	Schlumberger/Sprague Diaphragm Meters	240, 250, 305, 400, 400A, 675, 1000, 2, 3, 4, 5, 5A
American RVP-VI <sup>1</sup> or Mercury 206 Pulse Transmitter <sup>2, 3</sup>	American Diaphragm Meters	AC 630, AL 800, AL 1000, AL 1400, AL 2300, AL 5000, 25-B, 35-B, 60-B, 80-B, 250-B, 500-B
	Sensus/Invensis/Equimeter/Rockwell Diaphragm Meters	750, 800, 1000, 3000, 5000, 10000, 2, 2-1/2, 3, 4, 4-1/2, 5
	Itron/Actaris/Schlumberger/Sprague Diaphragm Meters	675A, 800A, 1000A

<sup>1</sup> One pulse per revolution of the index test hand.

<sup>2</sup> One pulse per revolution of the instrument drive.

<sup>3</sup> American Meter Mounting Kit Part #20-4187, MS Code 230504 is required to install Mercury 206 Pulse Transmitter on Rockwell and Sprague meters.

**Ordering Instructions**

When ordering a volume pulser, specify the make and model of the pulser and the make and model of the gas meter.

**Volume Pulse Output Connection for Gas Meters**

**J-65.1**

Rev. #04 10-01-13

**Target Audience**

Gas control technicians, gas measurement technicians, gas transmission and regulation (T&R) supervisors, gas estimators and gas engineers

**Definitions**

NA

**Acronyms and Abbreviations**

Vac: Volt alternating current  
AWG: American wire gauge  
Vdc: Volt direct current  
NEC: *National Electric Code*

**Compliance Requirement/ Regulatory Commitment**

NA

**References**

<a href="#">Volume Pulse Output Connection for Mercury Electronic Correctors</a> .....	<a href="#">J-65.2</a>
<a href="#">Agreement to Install Applicant Requested Common Special Facilities - Gas and Electric Rule 2</a> .....	<a href="#">79-1049</a>

**Appendices**

NA

**Attachments**

NA

**Revision Notes**

Revision 04 has the following changes:

1. Added AC-630 in Table 2.
2. This document is part of Change 66.

**Asset Type:** Gas Metering

**Function:** Design and Construction

**Document Contact:** [Gas Design Standard Responsibility List](#)

*cited in Cal. Rest. Ass'n v. City of Berkeley  
No. 21-16278am archived December 27, 2023*



## GAS DESIGN STANDARD METER GUARD DESIGN AND INSTALLATION ARRANGEMENT

J-95

Publication Date: 05/15/2019    Effective Date: 08/15/2019    Rev. 3a

### Purpose and Scope

This gas design standard (GDS) provides requirements and instructions for selecting and installing new and retrofitted gas meter guards for residential and commercial meters subject to vehicular traffic. This GDS is used during other meter set work to correct any unprotected meter sets. These meter guards protect against incidental bump damage during typical low-speed maneuvering (i.e., turning, backing, etc.). Post installation must be done in accordance with Utility Standard TD-4412S, "Preventing Damage to Underground Facilities." Always Dig Safely and call 1-800-227-2600 before digging.

### General Information

1. Physical protection must be provided for any gas meter set located in one of the areas described below:

#### A. Type 1 Locations

(1) Within 3' of the following:

- A single-family driveway or parking area.
- A roadway, street, alley, or driveway with a curb.

(2) Within 8' of the following:

- Multi-family driveway or parking area.
- A roadway, street, alley, or driveway without a curb.

#### B. Type 2 Locations

(1) Within 3' of a commercial refuse container location.

(2) Within 8' of the following:

- A commercial or industrial driveway or parking area.
- A loading dock or freight handling area.



**Meter Guard Design and Installation Arrangement****J-95**

Publication Date: 05/15/2019 Effective Date: 08/15/2019 Rev. 3a

**Selection and Installation**

1. If a meter location is at risk of vehicular damage, protect the location with barrier posts as follows:
    - Install meter posts so that they do not obstruct vehicular traffic, inconvenience customers, or hamper gas meter maintenance and meter reading.
    - Install all utilities before installing the barrier posts.
    - Provide barrier posts on all sides of the meter set that are exposed to vehicle hazards and that are not already protected by existing structures. Final arrangement of the barriers must not allow a vehicle approaching at any angle to damage the meter set.
    - Install all posts at the same height.
  2. Protection for Type 1 Locations
    - A. A 2" diameter post should be used to provide protection for meter sets in Type 1 locations. See Figures 1–4 and Tables 1–3 for installation instructions. Protect gas meter sets in residential areas using minimum 2" diameter, Schedule 40 steel posts.
  3. Protection for Type 2 Locations
    - A. A 4" diameter post should be used to provide protection for meter sets in Type 2 locations. See [Figures 1–4](#) and [Tables 1–3](#) for installation instructions. Protect gas meter sets in commercial and industrial areas using concrete-filled, minimum 4" diameter, Schedule 40 steel posts.
- Note:** When field conditions do not permit exact compliance with these requirements, alternatives may be proposed. Alternative meter guard arrangements must sufficiently protect the meter set and ensure adequate distance for maintenance and meter reading. A meter guard may be used in conjunction with man-made barriers such as wing-walls, planters, fences, etc., to provide protection; these barriers may be 6" or higher curbs, large trees, permanently installed planters, barrier posts, fences, or other similar permanent structures.

### Meter Guard Design and Installation Arrangement

J-95

Publication Date: 05/15/2019 Effective Date: 08/15/2019 Rev. 3a

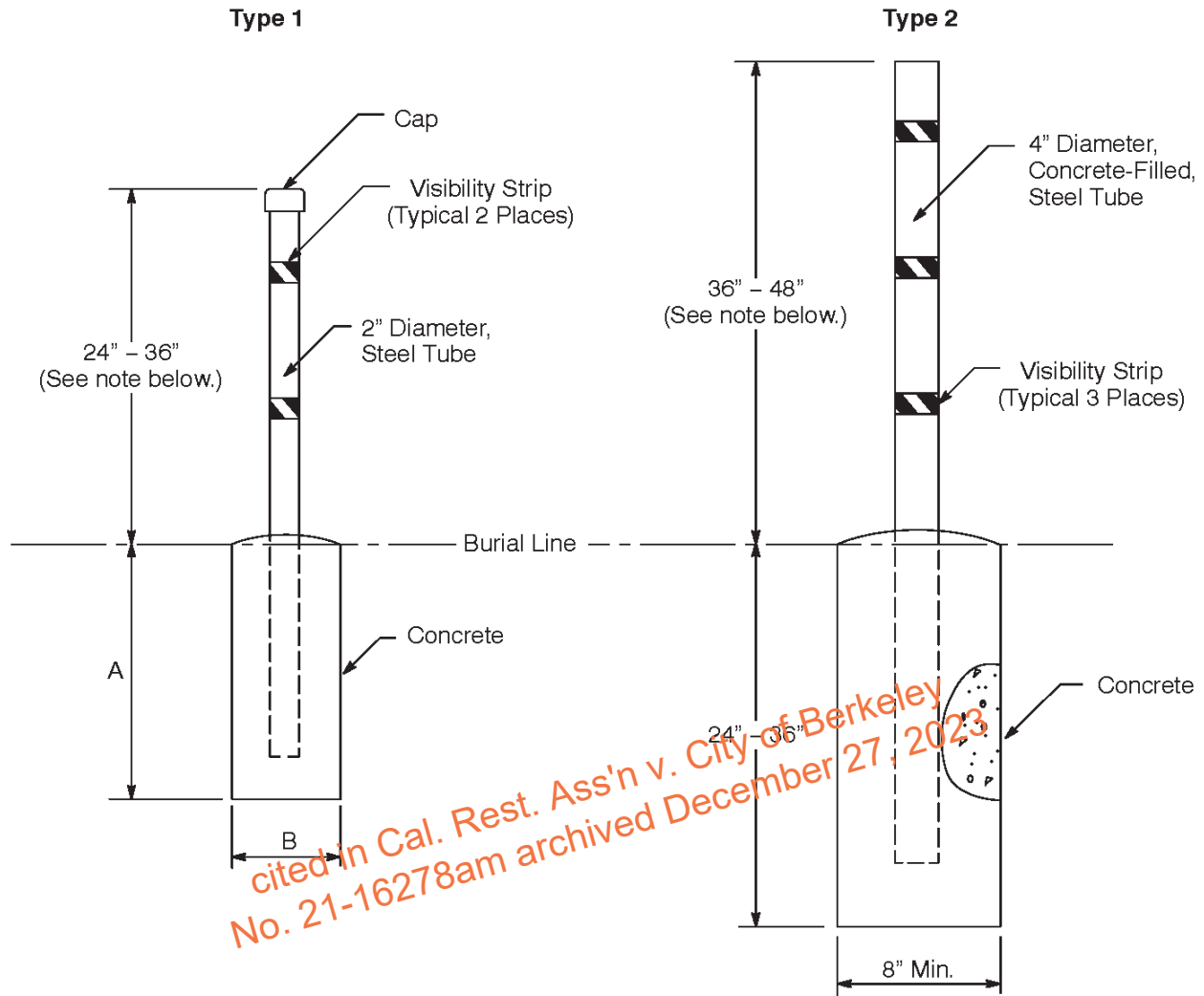


Figure 1. Post Installation

**Note:** Post should extend 6" above the highest point on the meter set, but not to exceed maximum height above grade.

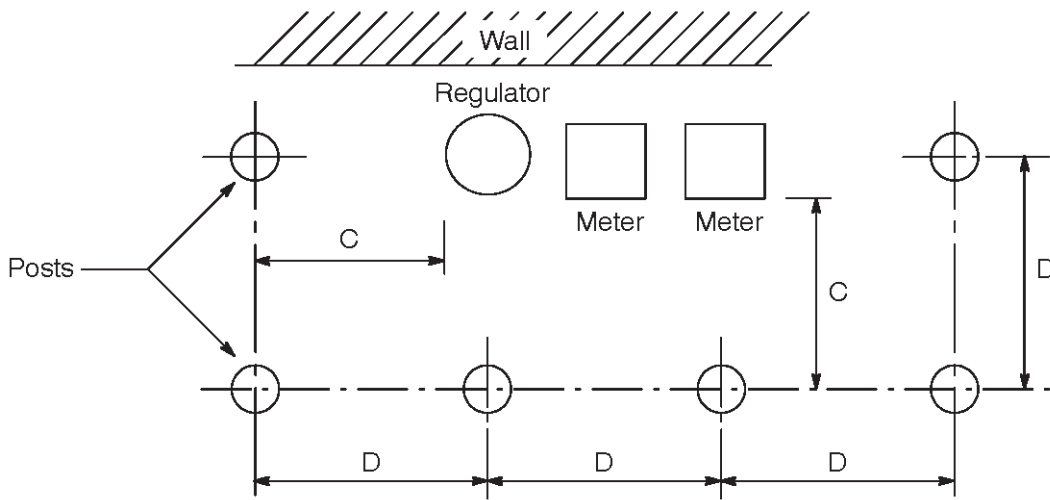
Table 1. Dimensions for Concrete Footing

A (inches)	B (inches)
12	8
15	8
20	6

### Meter Guard Design and Installation Arrangement

J-95

Publication Date: 05/15/2019 Effective Date: 08/15/2019 Rev. 3a



**Note:** The concrete footing must be at least 6" away from any point on the riser. If the post is positioned above an underground gas service, a minimum distance of 3" must be maintained between the service and the concrete footing.

Figure 2. Multiple Meters Post Arrangement

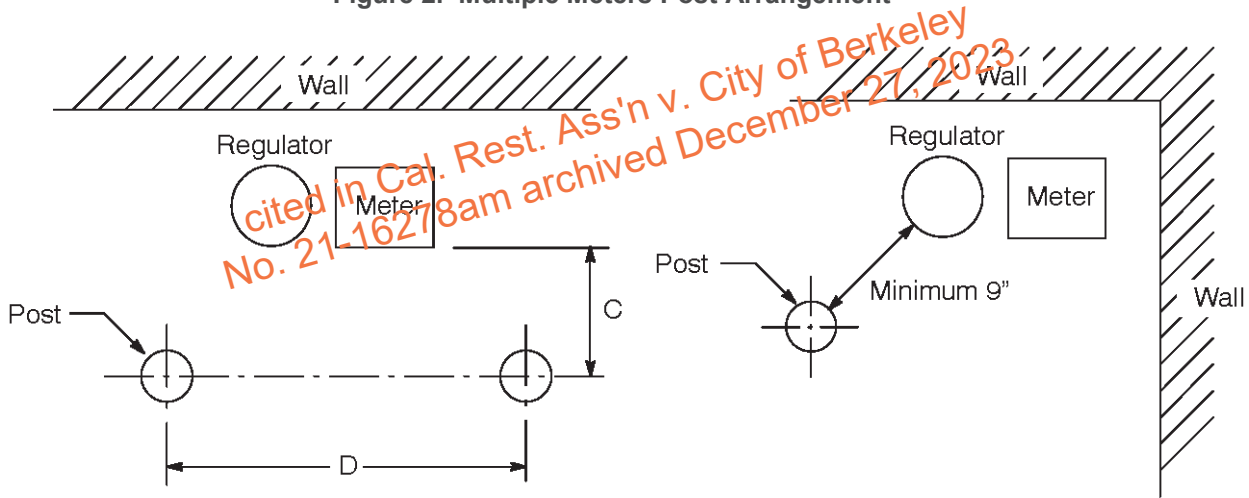


Figure 3. Single Meter Post Arrangement

Figure 4. Single Post Arrangement

Table 2. Dimensions for Post Arrangement

C <sup>1</sup> (inches)	Maximum D <sup>2</sup> (inches)
Less than 12	Space posts to prevent vehicle from contacting meter set, but leaving room for meter access and maintenance.
12	18
15	24
18	30
24	42

<sup>1</sup> Distance to meter or regulator.

<sup>2</sup> May not be more than 42".

**Meter Guard Design and Installation Arrangement****J-95**

Publication Date: 05/15/2019 Effective Date: 08/15/2019 Rev. 3a

**Table 3. Post Materials**

Description	Length	Code
Yellow - 2" Diameter, Schedule 40, Galvanized Pipe, with Reflective Tape 2" wide, and Steel Cap	56"	150117
Gray - 2" Diameter, Schedule 40, Galvanized Pipe with Reflective Tape 2" wide, and Steel Cap	56"	234188
Yellow - 4" Diameter, Schedule 40, Galvanized Pipe, with Reflective Tape 2" wide	78"	150122

**Riser Protection Method**

1. This method may be implemented in cases where only impact perpendicular to the structure is a threat. If there is a threat of lateral impact, install standard meter posts.
  - A. A 4-1/2" Split Steel Pipe With Mounting Flanges

**WARNING**

Respiratory distress can result from welding flanges onto galvanized steel if the area is not well-ventilated or an approved respirator is not worn.

- Use caution when welding flanges onto galvanized steel.
- Bolt pipe directly to the existing structure.

**CAUTION**

Covering the service valve makes the valve impossible to access without first removing the riser protection.

- Use to cover any portion of the riser in danger of vehicular damage, but **DO NOT** cover the service valve.
- See [Figures 5 and 6](#), and [Table 4](#), for installation instructions.

### Meter Guard Design and Installation Arrangement

J-95

Publication Date: 05/15/2019 Effective Date: 08/15/2019 Rev. 3a

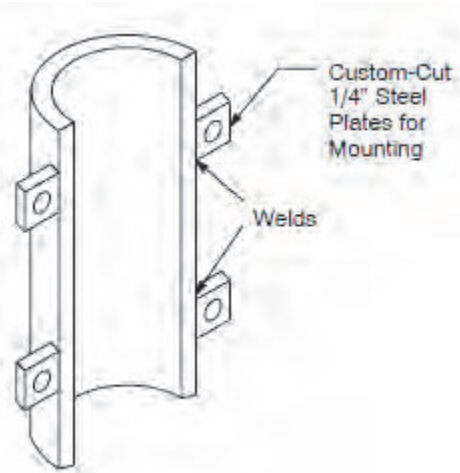


Figure 5. Riser Protection Method

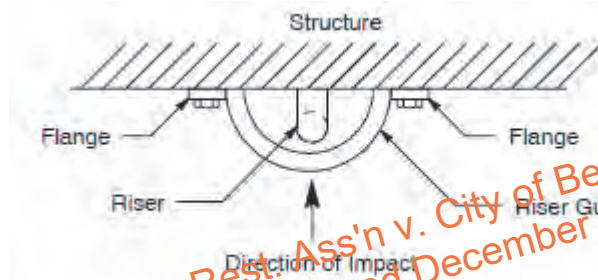


Figure 6. Riser Protected by Riser Guard

*cited in Cal. Res. Ass'n v. City of Berkeley  
No. 21-16278am archived December 27, 2023*

Table 4. Materials for Riser Protection

Description	Code
4-1/2" Half-Rolled Steel Pipe, Galvanized	150133

#### Target Audience

Design engineering, estimating, field services, maintenance and construction (M&C), gas transmission and regulation (T&R), and general construction (GC) personnel, and damage prevention process owners.

#### Definitions

NA

**Meter Guard Design and Installation Arrangement****J-95**

Publication Date: 05/15/2019 Effective Date: 08/15/2019 Rev. 3a

**Acronyms and Abbreviations**

CFR:	Code of Federal Regulations
DOT:	Department of Transportation
GC:	General Construction
GDS:	Gas Design Standard
M&C:	Maintenance and Construction
T&R:	Transmission and Regulation

**Compliance Requirement/Regulatory Commitment**

California Fire Code, Section (§) 603.9, "Gas meters."

Code of Federal Regulations (CFR) Title 49, Transportation, Part 192—Transportation of Natural and other Gas by Pipeline: Minimum Federal Safety Standards, §192.803, "Definitions."

49 CFR §192.353, "Customer meters and regulators: Location."

**References**

American Welding Society, Safety and Health Fact Sheet No. 25: Metal Fume Fever

Electric and Gas Service Requirements, "Meter Protection"

Gas Design Standard J-15, "Gas Meter Locations"

Utility Standard TD-4412S, "Preventing Damage to Underground Facilities"

**Appendices**

NA

**Attachments**

NA

**Revision Notes**

Revision 3a has the following changes:

1. In Table 3, added new material code for gray 2" posts, and added color descriptions to the two other protection posts listed in the table.

Revision 3 (Publication Date: 10/18/2017 Effective Date: 11/01/2017) has the following changes:

1. Moved the Dig Safely message from the bottom of each page to the Purpose and Scope section.
2. Re-wrote Selection and Installation section for greater clarity.
3. In Table 3, added new descriptions of the protection posts, and removed stand-alone visibility strips and 2" end cap.

**Meter Guard Design and Installation Arrangement**

**J-95**

**Publication Date:** 05/15/2019 **Effective Date:** 08/15/2019 **Rev.** 3a

---


**Asset Type:** Distribution Mains, Distribution Services, Measurement & Control

**Function:** Design, Construction, Maintenance and Operation

**Document Contact:** [Gas Design Standard Responsibility List](#)

*cited in Cal. Rest. Ass'n v. City of Berkeley  
No. 21-16278am archived December 27, 2023*

Prepared by: JTMZ

	<b>SINGLE METER CABINET FOR DOMESTIC GAS METERS</b>	<b>K-51</b>
<b>Asset Type:</b> Gas Metering	<b>Function:</b> Design and Construction	
<b>Issued by:</b> S. A. Robinson	Original Signed By	<b>Date:</b> 11-18-11
<b>Rev. #01:</b> This document replaces Revision #00. For a description of the changes, see Page 4.		

### Purpose and Scope

This numbered document provides specifications and ordering information for single, residential gas meter cabinets.

### Safety Note

The cabinets shown in this numbered document are intended to be built into the wall of a structure. The fabricated non-flammable/non-metallic cabinet and door(s) **must** be sealed at all joints and penetrations from the inside with caulking or other appropriate sealant and **must** be vented to the outside to prevent any gas from leaking into the structure. If constructed from wood, it must be lined with sheet rock or other non-flammable material.

The prefabricated American Gas Products (AGP) ABS plastic cabinet part number J-40 (with solid cover) is an approved alternate for the fabricated cabinet. Order from American Gas Products (AGP) Inc. P.O. Box 4777, Anaheim, CA 92803.

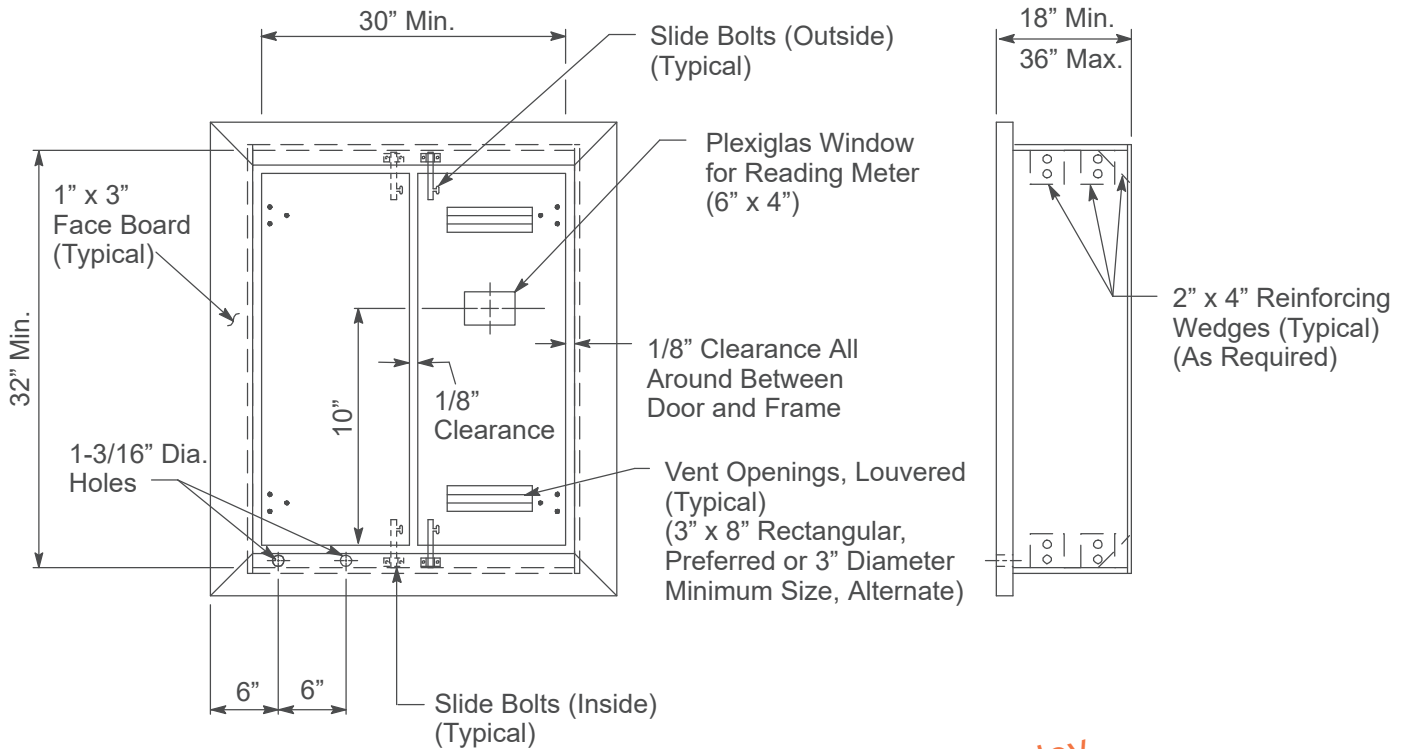
### General Information

#### Fabricated Non-Flammable/Non-Metallic Cabinets (see Figure 1)

1. Cabinets and door(s) shall be made from non-flammable wall board, or other suitable material. If constructed from wood, it must be lined with sheet rock or other non-flammable material. Review local codes to ensure that the cabinet complies with any fire rating requirements.
2. Cabinets and cabinet doors shall not be fabricated from metal in order to minimize the potential for interference with SmartMeter radio frequency (RF) signal transmission.
3. Seal all joints and penetrations from the inside with caulking or other appropriate sealant.
4. The box width and height dimensions are the minimum inside dimensions needed for maintenance and operating activities. These dimensions may be increased to suit local conditions, but should be kept as close as practical to the specified minimums to discourage customers from using the box for storage purposes.
5. The right side door should be louvered or otherwise vented at the top and bottom as shown. It shall be held closed with two slide-bolt latches located on the outside. Other types of latches can be used.
6. Lock the solid door closed using two slide-bolt latches located on the inside. Both doors shall open fully to allow servicing of the meter and regulator.
7. Electrical wiring is permitted in the cabinet only if the wiring is within sealed conduit with no joints, or the wiring meets the requirements of the National Electric Code for Class I, Division 1 areas. The conduit must not interfere with the meter, regulator, or piping.
8. Take care not to paint the cabinet vents or the regulator's internal relief valve (IRV) vent termination fitting openings and thereby obstruct the flow of air or gas.



## Single Meter Cabinet for Domestic Gas Meters

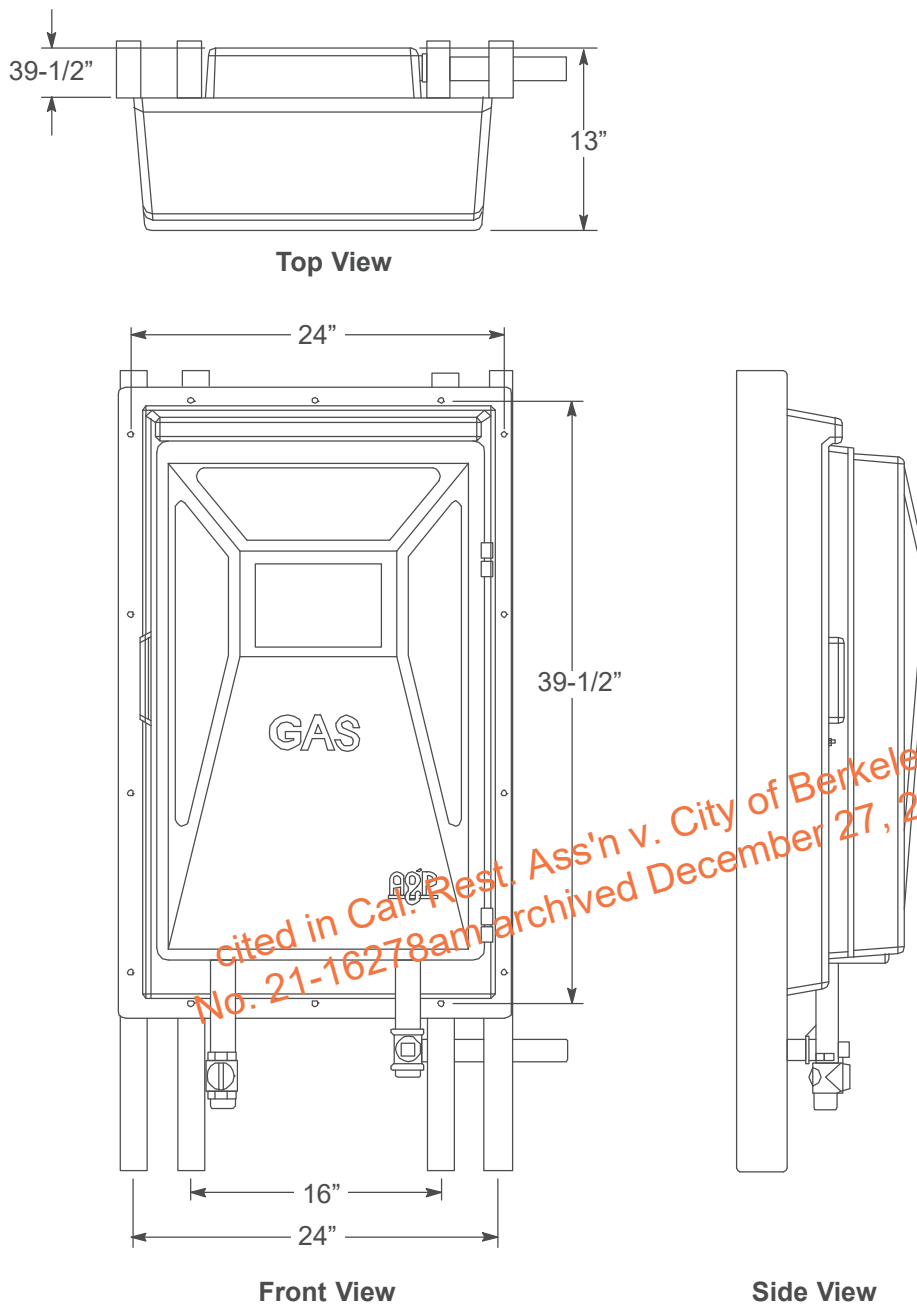


**Figure 1**  
Meter Cabinet

### Prefabricated Plastic Cabinets (see Figure 2)

1. The cabinet is designed to fit between studs on 16" centers.
2. Add a second 2"x4" on each side of the cabinet to support the flange.
3. Meter sizes up to AC630 will fit in the cabinet.
4. Align the gas service riser with the "R" marking on the left side of the cabinet and stub out the connection to the customer's houseline to align with the "HL" marking on the right side of the cabinet. Do not drill into or penetrate the back, sides, top, or bottom of the cabinet.
5. Locate the meter to align with the figure outlined on the rear of the cabinet and connect the inlet and outlet piping as shown in Figure 3 on Page 4.
6. The cabinet cover may be painted to match the building.

### Single Meter Cabinet for Domestic Gas Meters



**Figure 2**  
**Prefabricated Plastic Meter Cabinet Dimensional Views**

### Single Meter Cabinet for Domestic Gas Meters

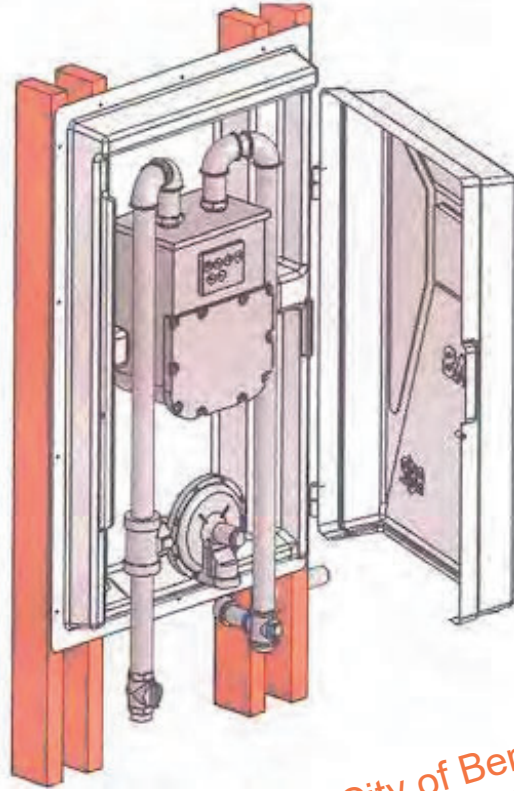


Figure 3  
Prefabricated Plastic Meter Cabinet Piping Installation View


*cited in Cal. Rest. Ass'n v. City of Berkeley  
No. 21-16278am archived December 27, 2023*

#### Revision Notes

Revision 01 has the following changes:

1. Added alternate prefabricated plastic cabinet.
2. Changed description to "Cabinet" to agree with Numbered Document J-15.
3. Added non-metallic cabinet door material requirement for SmartMeter RF signal transmission.
4. Added maximum cabinet depth of 36".
5. This document is part of Change 64.

Prepared by: C1K8

	<b>GAS PIPELINE UNDERGROUND WARNING TAPE</b>		<b>L-16</b>
	<b>Asset Type:</b> Gas Transmission and Distribution <b>Issued by:</b> S. van Oosten	 <div style="border: 1px solid red; padding: 2px; display: inline-block;">Original Signed By</div>	<b>Function:</b> Design & Construction <b>Date:</b> 05-01-13
<b>Rev. #00:</b> This is a new document. For a description of the changes, see Page 2			

**Purpose and Scope**

This numbered document provides guidelines for purchasing and installing underground warning tape above gas pipelines. The installation of the warning tape applies to all open trench installation of gas pipelines.

**Acronyms**

**References**

**Document**

<a href="#">Design and Construction Requirements Gas Lines and Related Facilities</a> .....	<a href="#">A-36</a>
<a href="#">Plastic Gas Distribution System Construction and Maintenance</a> .....	<a href="#">A-93.1</a>
<a href="#">Joint Trench</a> .....	<a href="#">S5453</a>

**General Information**

1. A warning tape is to be installed in open trench installation over gas pipelines in both Transmission and Distribution facilities. This includes trenches, bell holes, excavations for repair purposes and riser replacements. The warning tape is intended for excavator digging in the "tolerance zone" to strike the warning tape prior than the pipeline. When the warning tape is exposed and grabbed with excavating equipment, it stretches without breaking, thus alerting the excavator of the gas facility below.
2. Install 6" wide warning tape above the gas pipeline at least 12" below grade, and no closer than 12" from the pipe. Installation should provide the greatest distance between the pipeline and the tape as possible. Install the tape along the length of the excavation. Ensure that the tape overlaps when two or more pieces of tape are used.

EXCEPTION: When a joint trench design does not allow for installment of warning tape within the "warning tape installation zone", install the warning tape a minimum of 6" above the gas pipeline, and below the facility above the pipe.

3. Warning tape shall be brightly colored yellow and marked "Caution: Gas Line Buried Below" or marked with a similar notification.
4. Warning tape shall be stored in such a manner that limits Ultraviolet (UV) exposure.

### Gas Pipeline Underground Warning Tape



**Figure 1**  
Gas Pipeline Underground  
Warning Tape

**Table 1** Material Specification for Figure 1

Description	Dimensions	Material Code
1 Roll (Terra Tape)	6" x 1000'	379947



**Figure 2**  
Gas Pipeline Underground Warning  
Tape Installation

**Revision Notes**

Revision 00 has the following changes:

1. This is a new document.
2. This document is part of Change 66.



## GAS DESIGN STANDARD PG&E-APPROVED GAS MATERIALS MANUFACTURERS

N-01

Publication Date: 08/21/2019 Effective Date: 11/21/2019 Rev. 4a

### Purpose and Scope

This gas design standard (GDS) provides a partial list (see Table 1) of current Pacific Gas & Electric Company (PG&E or Company) approved manufacturers included in the Green Book for those without access to the complete list currently available via SAP.

### General Information

1. Not every Company-approved manufacturer supplies all the approved variations of each commodity. Refer to the appropriate reference document for approved part descriptions.
2. If a plant location is not listed, then material from all manufacturing locations operated by the named manufacturer is approved for use. If a plant location is listed, then only material manufactured at that approved location is acceptable.
3. The complete list of Company-approved manufacturers is stored and managed in the Qualified Suppliers List (QSL) on SAP. If other materials are needed, contact your local PG&E representative to obtain information from SAP.

**Table 1. PG&E-Approved Manufacturers**

Material	Approved Manufacturer (Plant)	Document Reference
PE Electrofusion Fittings and Tapping Tees	Innogaz (Goa, India and Mannheim, Germany)	GDS B-90.3, "Electrofusion Fittings and Tapping Tees"
	IPEX-Friatec (Mannheim, Germany)	
	Plasson (Ma'agan Michael, Israel)	
PE Excess Flow Valves	Honeywell Perfection (Geneva, OH)	<ul style="list-style-type: none"> <li>• GDS A-93.3, "Excess Flow Valves"</li> </ul>
PE Fittings Mechanical Transition	Chicago Fittings	<ul style="list-style-type: none"> <li>• GDS B-91, "Transition Fittings for Polyethylene Pipe"</li> </ul>
	Continental Industries (Tulsa, OK)	
	Normac	
PE Mechanical Fittings	Continental Industries (Tulsa, OK)	<ul style="list-style-type: none"> <li>• GDS B-91.1, "Polyethylene (PE) System Mechanical Fittings"</li> <li>• EMS-4761, "Non-Corrosible Mechanical Fittings for Polyethylene Gas Piping and Tubing"</li> </ul>
PE Pipe & Tubing	JM Eagle (Tulsa, OK)	<ul style="list-style-type: none"> <li>• GDS A-93, "Polyethylene Pipe Specifications and Design Considerations"</li> <li>• EMS-2502, "Specifications for Furnishing and Delivery of Polyethylene (PE) Plastic Tubing, ½ in. and 1 in."</li> <li>• EMS-2503, "Specifications for Furnishing and Delivery of Polyethylene (PE) Plastic Piping, 1-1/4 in. to 10 in."</li> </ul>
	Performance Pipe (Knoxville, TN)	
	Performance Pipe (Pryor, OK)	
	Performance Pipe (Reno, NV)	
	PolyPipe/Dura-line (Gainesville, TX)	

## PG&amp;E-Approved Gas Materials Manufacturers

N-01

Publication Date: 08/21/2019 Effective Date: 11/21/2019 Rev. 4a

Table 1. PG&amp;E-Approved Manufacturers (continued)

Material	Approved Manufacturer (Plant)	Document Reference
PE Saddle Fittings	Central Plastics (Shawnee, OK)	<ul style="list-style-type: none"> <li>GDS B-90.1, "Plastic System Saddle Fittings"</li> <li>EMS-4758, "Heat Fusion Fittings for Polyethylene (PE) Gas Piping and Tubing"</li> <li>EMS-4761, "Non-Corrodible Mechanical Fittings for Polyethylene Gas Piping and Tubing"</li> </ul>
	Continental Industries (Tulsa, OK)	
	Performance Pipe (Bloomfield, IA)	
PE Socket and Butt Fusion Fittings	Central Plastics (Shawnee, OK)	<ul style="list-style-type: none"> <li>GDS B-90, "Plastic System Socket and Butt Fusion Fittings"</li> <li>EMS-4758, "Heat Fusion Fittings for Polyethylene (PE) Gas Piping and Tubing"</li> </ul>
	Performance Pipe (Bloomfield, IA)	
PE System Accessories	Continental Industries (Tulsa, OK)	<ul style="list-style-type: none"> <li>GDS B-90.2, "Polyethylene (PE) System Accessories"</li> </ul>
	Performance Pipe (Bloomfield, IA)	
	JM Eagle (Tulsa, OK)	
	Innogaz (Goa, India and Mannheim, Germany)	
	Plasson (Ma'agan Michael, Israel)	
	Central Plastics (Shawnee, OK)	
PE Valves	Andronaco (Kentwood)	GDS F-90, "Polyethylene (PE) Valves"
	Honeywell Perfection (Geneva, OH)	
	Keotec (Mansoura, LA)	
Risers, Pre-Fabricated Gas Service, and Riser Kits	Honeywell -Perfection (Geneva, OH)	<ul style="list-style-type: none"> <li>GDS A-91, "Pre-Fabricated Risers"</li> <li>EMS-6421, "Specifications for Furnishing and Delivery of Pre-Fabricated Metal-Cased Plastic ¾ in. x ½ in. CTS and ¾ in. x 1 in. CTS Gas Service Risers"</li> <li>EMS-7030, "Specifications for Furnishing and Delivery of Pre-Fabricated Metal-Cased Plastic 1¼" x 1 CTS and 1¼" x 1¼" IPS Gas Service Risers"</li> </ul>
	R.W. Lyall (New Berlin, WI and Corona, CA)	
Standard Threaded Pipe Caps	Tube Forgings of America (Forged Steel)	<ul style="list-style-type: none"> <li>GDS B-10, "Standard Pipe Caps"</li> </ul>
	Ward (Malleable Iron)	
	Mill Iron Works (Forged Steel)	
Threaded Pipe Plugs	Bonney Forge (Forged Steel)	<ul style="list-style-type: none"> <li>GDS B-10.1, "Standard Pipe Plugs"</li> </ul>
	Advance Engineering (Cast Iron)	
Standard Threaded Steel Pipe Nipple	Perfect Pipe	<ul style="list-style-type: none"> <li>GDS B-13, "Standard Threaded Steel Pipe Nipple"</li> </ul>
	Jinan Meide	
Extra Heavy Threaded Steel Pipe Nipples, Toe Pipe Nipples	Perfect Pipe	<ul style="list-style-type: none"> <li>GDS B-13.1, "Extra Heavy Pipe Nipples"</li> <li>GDS B-13.2, "Threaded One End Pipe Nipples (Toe)"</li> <li>GDS B-13.4, "Branch Nipple"</li> </ul>

## PG&amp;E-Approved Gas Materials Manufacturers

N-01

Publication Date: 08/21/2019 Effective Date: 11/21/2019 Rev. 4a

Table 1. PG&amp;E-Approved Manufacturers (continued)

Material	Approved Manufacturer (Plant)	Document Reference
Swage Nipples	Mill Iron Works	<ul style="list-style-type: none"> <li>GDS B-13.3, "Concentric Reducing Nipple (Swage Nipple)"</li> </ul>
	Perfect Pipe	
Stainless Steel Pipe Nipples	Swagelok	<ul style="list-style-type: none"> <li>GDS B-13.5, "Stainless Steel Threaded Nipple"</li> </ul>
	Hoke	
	SSP TruFit	
Threaded Tees, Elbows, Unions, and Bushings	Bonney Forge (Forged Steel)	<ul style="list-style-type: none"> <li>GDS B-12, "Standard 90° Threaded Elbows"</li> <li>GDS B-12.1, "Standard Reducing 90° Elbows"</li> <li>GDS B-12.2, "Standard 90° Threaded Street Elbows"</li> <li>GDS B-12.3, "45° Threaded Elbow"</li> <li>GDS B-14, "Standard Threaded Tee"</li> <li>GDS B-14.1, "Standard Threaded Street Tee"</li> <li>GDS B-14.2, "Reducing Threaded Tee"</li> <li>GDS B-15, "Standard Threaded Unions"</li> <li>GDS B-15.1 "Threaded Bushing"</li> </ul>
	Ward (Malleable Iron)	
	Anvil (Malleable Iron)	
Steel One-Piece Line Stopper Fittings	Mueller	<ul style="list-style-type: none"> <li>GDS C-16.3, "Mueller H-17190 Welding Line Stopper Fitting"</li> <li>GDS C-16.4, "Mueller H-17191 Mechanical Joint Like Stopper Fitting"</li> <li>GDS C-64.1, "TDW Shortstop H-6"—12" Fitting"</li> </ul>
	TDW	
Steel Save-A-Valves	Mueller	<ul style="list-style-type: none"> <li>GDS C-14, "Mueller Save-A-Valve Nipples"</li> </ul>
<2" Diameter Steel Seamless Pipe	PTC Alliance (Darlington, SC)	<ul style="list-style-type: none"> <li>GDS A-15, "Code Numbers for Steel Pipe"</li> </ul>
	Michigan Seamless Tube (South Lyon, MI)	
	Bentler Tube & Steel (Shreveport, LA)	
Steel Service Tees	Continental Industries (Tulsa, OK)	<ul style="list-style-type: none"> <li>GDS C-10, "Mueller Service Tees Types H-17500 and H-17501"</li> <li>GDS C-10.1, "Mueller Flanged Tees Types H-17505 and H-17506"</li> <li>GDS C-11, "Mueller Valve, Tee-Type H-17656"</li> <li>GDS C-13, "Service Tapping Tee with Coupon Retaining Punch"</li> <li>GDS B-91, "Transition Fittings for Polyethylene Pipe"</li> </ul>
	Mueller	
Steel Two-Piece Line Stopper Fittings	Mueller	<ul style="list-style-type: none"> <li>GDS C-15.2, "Mueller Welding Line Stopper Fittings H-17055, H-17056, H-17155, and H-17156"</li> <li>GDS C-15.3, "Mueller Welding Line Stopper Fittings H-17255, H-17256, H 17257, H-17275, H-17276, and H-17277"</li> </ul>
	Blackhawk (Stopple fitting)	
	TDW (Stopple fitting)	
Steel Two-Piece Line Stopper Fittings with Bottom Connection	Mueller	<ul style="list-style-type: none"> <li>GDS C-16.2, "Mueller Welding Line Stopper Fittings with Bottom Connection"</li> </ul>
Steel Two-Piece Spherical Line Stopper Fittings with Bottom or Side Connection	Mueller	<ul style="list-style-type: none"> <li>GDS C-17, "Mueller Spherical Line Stopper Fittings"</li> </ul>
Steel Unions Insulated Threaded	Central Plastics	<ul style="list-style-type: none"> <li>GDS O-23, "Insulated Threaded Unions"</li> </ul>



**PG&E-Approved Gas Materials Manufacturers****N-01**

Publication Date: 08/21/2019 Effective Date: 11/21/2019 Rev. 4a

**Target Audience**

Personnel involved in gas engineering and construction inspection.

**Definitions**

NA

**Acronyms and Abbreviations**

PE: Polyethylene  
 QSL: Qualified Suppliers List

**Compliance Requirement / Regulatory Commitment**

Code of Federal Regulations (CFR) Title 49, Part 192—Transportation of Natural and other Gas by Pipeline: Minimum Federal Safety Standards, Subpart B—Materials

**References**

EMS-2502, "Specifications for Furnishing and Delivery of Polyethylene (PE) Plastic Tubing, 1/2 in. and 1 in."

EMS-2503, "Specifications for Furnishing and Delivery of Polyethylene (PE) Plastic Piping, 1-1/4 in. to 10 in."

EMS-4758, "Heat Fusion Fittings for Polyethylene (PE) Gas Piping and Tubing"

EMS-4761, "Non-Corrosible Mechanical Fittings for Polyethylene Gas Piping and Tubing"

EMS-6421, "Specifications for Furnishing and Delivery of Pre-Fabricated Metal-Cased Plastic 3/4 in. x 1/2 in. CTS and 3/4 in. x 1 in. CTS Gas Service Risers"

EMS-7030, "Specifications for Furnishing and Delivery of Pre-Fabricated Metal-Cased Plastic 1 1/4" x 1" CTS and 1 1/4" x 1 1/4" IPS Gas Service Risers"

GDS A-15, "Code Numbers for Steel Pipe"

GDS A-91, "Prefabricated Risers"

GDS A-93, "Polyethylene Pipe Specifications and Design Considerations"

GDS A-93.3, "Excess Flow Valves"

GDS B-10, "Standard Pipe Caps"

GDS B-10.1, "Standard Pipe Plugs"

GDS B-11, "Standard Threaded Pipe Couplings"

**PG&E-Approved Gas Materials Manufacturers****N-01****Publication Date:** 08/21/2019 **Effective Date:** 11/21/2019 **Rev.** 4a**References (continued)**

- GDS B-11.1, "Threaded Reducers (Bell Reducers)"
- GDS B-12, "Standard 90° Threaded Elbows"
- GDS B-12.1, "Standard Reducing 90° Elbows"
- GDS B-12.2, "Standard 90 Degree Threaded Street Elbows"
- GDS B-12.3, "45° Threaded Elbow"
- GDS B-12.4, "Reducing Street Elbow"
- GDS B-13, "Standard Threaded Pipe Nipples"
- GDS B-13.1, "Extra Heavy Pipe Nipples"
- GDS B-13.2, "Threaded One End Pipe Nipples (TOE)"
- GDS B-13.3, "Concentric Reducing Nipple (Swage Nipple)"
- GDS B-13.4, "Branch Nipple"
- GDS B-14, "Standard Threaded Tee"
- GDS B-14.1, "Standard Threaded Street Tee"
- GDS B-14.2, "Reducing Threaded Tee"
- GDS B-15, "Standard Threaded Unions"
- GDS B-15.1, "Threaded Bushing"
- GDS B-90, "Plastic System Socket and Butt Fusion Fittings"
- GDS B-90.1, "Plastic System Saddle Fittings"
- GDS B-90.2, "Polyethylene (PE) System Accessories"
- GDS B-90.3, "Electrofusion Fittings and Tapping Tees"
- GDS B-91, "Transition Fittings for Polyethylene Pipe"
- GDS B-91.1, "Polyethylene (PE) System Mechanical Fittings"
- GDS C-10, "Mueller Service Tees Types H-17500 and H-17501"
- GDS C-10.1, "Mueller Flanged Tees Types H-17505 and H-17506"

*cited in Cal. Rest. Ass'n v. City of Berkeley  
No. 21-16278am archived December 27, 2023*

**PG&E-Approved Gas Materials Manufacturers****N-01****Publication Date:** 08/21/2019 **Effective Date:** 11/21/2019 **Rev.** 4a

---

**References (continued)**

GDS C-11, "Mueller Valve, Tee-Type H-17656"

GDS C-13, "Service Tapping Tee with Coupon Retaining Punch"

GDS C-14, "Mueller Save-A-Valve Nipples"

GDS C-15.2, "Mueller Welding Line Stopper Fittings H-17055, H-17056, H-17155, and H-17156"

GDS C-15.3, "Mueller Welding Line Stopper Fittings H-17255, H-17256, H-17257, H-17275, H-17276, and H 17277"

GDS C-16.1, "Mueller Extension Stopper Fitting for Lateral Connections"

GDS C-16.2, "Mueller Welding Line Stopper Fittings with Bottom Connection"

GDS C-16.3, "Mueller H-17190 Welding Line Stopper Fitting"

GDS C-16.4, "Mueller H-17191 Mechanical Joint Line Stopper Fitting"

GDS C-16.5, "Mueller Extension Stopper Fitting for Lateral Connection"

GDS C-63, "T.D. Williamson M-Stopp Fitting (Mueller Compatible)"

GDS C-64.1, "TDW Shortstop 1/6"—12" Fitting"

GDS F-80, "Meter Valves"

GDS F-90, "Polyethylene (PE) Valves"

GDS J-50, "Meter Swivels and Swivel Nuts"

GDS J-52.1, "Gas Meter Manifolds (1-1/4" and 2" Sizes)"

GDS O-23, "Insulated Threaded Unions"

**Appendices**

NA

**Attachments**

NA

*cited in Cal. Rest. Ass'n v. City of Berkeley  
No. 21-16278am archived December 27, 2023*

**PG&E-Approved Gas Materials Manufacturers****N-01****Publication Date:** 08/21/2019 **Effective Date:** 11/21/2019 **Rev. 4a****Revision Notes**

Revision 4a has the following changes:

1. Table 1: Deleted cast iron material; extension stopper fittings; KWH as approved manufacturer for the PE Pipe & Tubing material group; and Chicago Fittings from the Risers, Pre-Fabricated Gas Service, and Riser Kits material group.
2. Table 1: Added JM Eagle (Tulsa, OK), Plasson (Ma'agan Michael, Israel), Innogaz (Goa, India and Mannheim, Germany), and Central Plastics (Shawnee, OK) to the PE System Accessories group; Benteler to the <2" Diameter Steel Seamless Pipe group; TDW to the Steel Two-Piece Line Stopper Fittings group.
3. Table 1: Minor clarifications.

Revision 4, published 06/19/2019 and effective 09/18/2019, has the following changes:

1. Purpose and Scope section revised to limit scope to a partial list of approved manufacturers for inclusion in the Green Book.
2. Removed Notes 1 and 4 from General Information section, adding new Note 3 highlighting that the SAP QSL is now the complete list of Company-approved manufacturers and revising original notes (now Notes 1 and 2).
3. Deleted items not typically applicable to applicant work from Table 1.


**Asset Type:** Gas Transmission and Compression

**Function:** Design

**Document Contact:** [Gas Design Standard Responsibility List](#)

cited in Cal. Rest. Ass'n v. City of Berkeley  
No. 21-16278am archived December 27, 2023

Prepared by: ABB1

	<h2 style="margin: 0;">CORROSION RESISTANT GROUND RODS AND GROUND ROD CLAMPS</h2>	<h2 style="margin: 0;">013109</h2>
<b>Asset Type:</b> Electric Distribution <b>Issued by:</b> Dan Mulkey (DHM3) <i>Daniel H. Mulkey</i>	<b>Function:</b> Design and Construction <b>Date:</b> 06-29-12	
<b>Rev. #06:</b> This document replaces PG&E Document 013109, Rev. #05. For a description of the changes, see Page 3.		

This document is also included in the following manual:

- [Electric and Gas Service Requirements Manual](#) (Greenbook)

### Purpose and Scope

This document describes corrosion resistant ground rods and ground rod clamps.

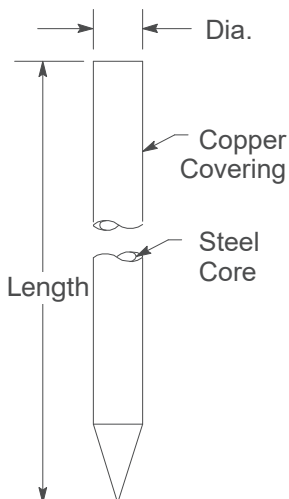
References	Location	Document
<a href="#">Methods of Grounding Steel Transmission Poles and Towers</a>	TIL	012566
<a href="#">Method of Grounding Fences and Wire Trellises</a>	TIL	020607
<a href="#">Installation of Grounds on Wood Pole Transmission and Distribution Lines</a>	OH: Transformers	021904
<a href="#">Ground Resistance and Resistivity Measurements</a>	ELS	053241

### Conventional Ground Rods

#### Notes

1. Ground rods shall meet the requirements of ANSI Spec. C33.8 (UL 467).
2. Welded-type connections may be used when welding equipment is available on the job.

cited in Cal. Rest. Ass'n v. City of Berkeley  
No. 21-16278am archived December 27, 2023



**Figure 1**  
Ground Rod

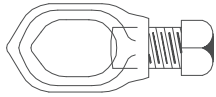
**Table 1 Conventional Ground Rods**

Dimensions		Minimum Copper Jacket Thickness (inches)	Code	Application	Mfr. <sup>1</sup>	Catalog Number
Dia.	Length					
5/8"	8'0"	0.010	187013	Normal Grounds for Pad-Mount and Pole Grounds	Nehring	NCC 588
					Galvan	6258
					Calpico	CP588
					Eritech	615880
3/4"	12'0"	0.010	010098	For Substation Grounds or Ground Rods Larger Than 8' 0" and All Subsurface Primary Enclosures	Eritech	613412
					Galvan	7512
					Nehring	NCC 3410

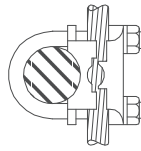
<sup>1</sup> Ground rods are to be furnished with the length and manufacturer's identification permanently marked on each rod.

### Corrosion Resistant Ground Rods and Ground Rod Clamps

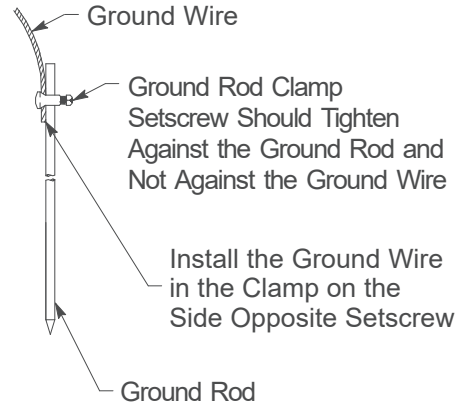
#### Ground Rod Clamps



**Figure 2**  
Standard Clamp



**Figure 3**  
Clamp for Large Wire



**Detail A**  
Installation of Ground Rod

**Table 2 Utility-Grade Ground Rod Clamps <sup>1</sup>**

Refer to	Ground Rod Diameter	Ground Wire Size – Copper	Code	Manufacturer	Catalog Number
Figure 2	5/8"	6 to 1/0	187012	Hubbell/Anderson	GC103-01
				Dossert	GN-62
				Eritech	HDC58H
				Eritech	SP58
				Galvan	JAB58HH
Figure 2	5/8" or 3/4"	2/0 to 4/0 With 5/8" Diameter Rod and 6 to 1/0 With 3/4" Diameter Rod	187017	Hubbell/Anderson	GC103-02
				Dossert	GN-75
				Galvan	JAB34HH
	3/4"	4/0 and 250 kcmil	187024	Hubbell/Anderson	GC103-03
				Dossert	GNS-75
Figure 3	5/8" or 3/4"	300 to 500 kcmil	187020	Hubbell/Anderson	GC-111-3D
				Burdud	GAR6434
				Royal	2022(DQ)

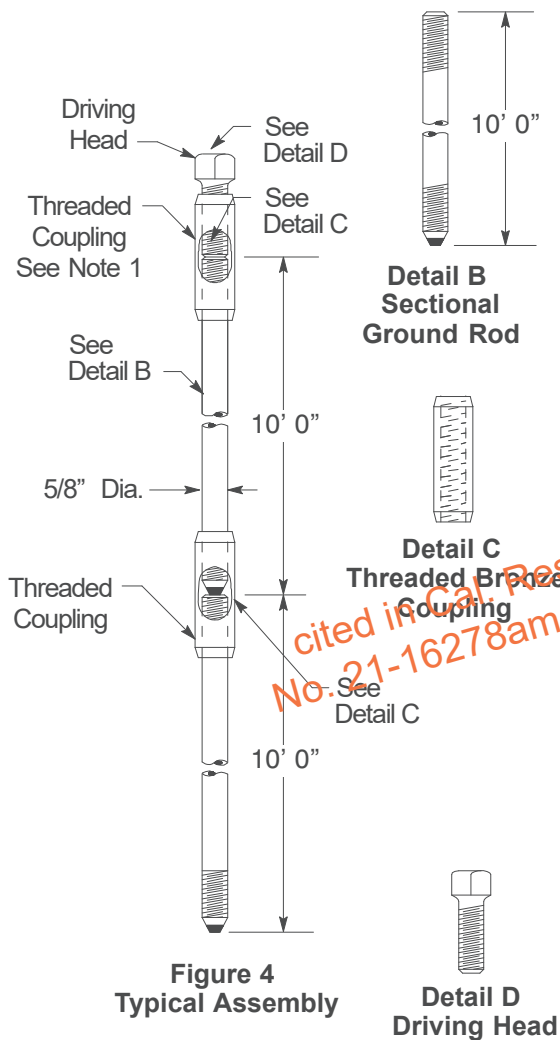
<sup>1</sup> The setscrew and clamp are to withstand approximately 35-40 foot-lbs. of torque on the setscrew head without cracking or breaking.

**Corrosion Resistant Ground Rods and Ground Rod Clamps**

**Sectional Ground Rods**

**Notes**

1. Remove the driving head and upper coupling from the ground rod to permit installing a ground rod clamp, (see Table 2 on Page 2), when the ground rod has been driven to its final depth.
2. After driving a second sectional rod, check the rod with a wrench to ensure that the bottom of the second rod is contacting the top of first rod in the threaded coupling. Repeat this check on each additional rod used.



**Table 3 Sectional-Type Ground Rods**

Dimensions		Code	Application	Manufacturer	Catalog Number
Dia.	Length				
5/8"	10'0"	187021	For Deep-Driven Ground Rods (see Document 053241)	Calpico	S5810T
				Eritech	635800
				Galvan	6260S

**Table 4 Threaded Bronze Coupling for 5/8" Diameter Sectional-Type Ground Rods**

Threaded Coupling Size	Code	Application	Mfr.	Catalog Number
5/8"	187022	For Connecting Ground Rods (see Table 3)	Calpico	C158
			Eritech	CR-58
			Galvan	60-C

**Table 5 Driving Head for 5/8" Diameter Sectional-Type Ground Rods**

Driving Head Size	Code	Application	Mfr.	Catalog Number
5/8"	187023	For Driving Ground Rods (see Table 3)	Calpico	D358
			Eritech	DS58
			Galvan	60-DS



**Revision Notes**

Revision 06 has the following changes:

1. Updated Table 2 on Page 2.



cited in Cal. Rest. Ass'n v. City of Berkeley  
No. 21-16278am archived December 27, 2023

	<b>CONNECTORS FOR INSULATED CABLES UNDERGROUND DISTRIBUTION SYSTEMS</b>		<b>015251</b>
	<b>Asset Type:</b> Electric Distribution	<b>Function:</b> Design and Construction	
<b>Issued by:</b> Lisseth Villareal (LDV2)		<b>Date:</b> 03-25-22	
<b>Rev. #07:</b> This document replaces PG&E Document 015251, Rev. #06. For a description of the changes, see Page 39.			

**Purpose and Scope**

This document provides application and ordering information for cable connectors and terminals for use in underground distribution systems.

**General:**

This document applies to connectors for copper-to-copper, copper-to-aluminum, and aluminum-to-aluminum conductors. The use of aluminum conductors and the necessity of splicing aluminum-to-copper presents some specific problems as follows.

1. All connectors shall meet the requirements of **ANSI C119 Class A**.
2. Oxide Film

Unlike copper, aluminum is normally covered with a thin, hard film of invisible aluminum oxide. This film is a good insulator and forms immediately whenever aluminum is exposed to air. Therefore, aluminum connectors must meet the following requirements.

- A. Connectors should exert sufficient pressure on the cable to break through the oxide film.
- B. Connectors should exert approximately equal pressures on all strands.

3. Thermal Expansion and Plastic Flow

The difference in the thermal expansion of copper and aluminum must be addressed. Aluminum expands and contracts approximately 38% more than copper with the same temperature change. Copper connectors and copper cables expand together as do aluminum connectors and aluminum cables.

If copper connectors are used on aluminum cables, the aluminum cable expands more than the copper connector. As the temperature rises this causes the aluminum to extrude out of the connector. When the joint cools, the copper connector cannot shrink to fit the reduced diameter of the aluminum conductor. This cycle, repeated over time, results in loose connections and high resistance joints. Therefore, it is important to use connectors that have the same coefficient of expansion as the cable. For example, copper connectors with copper cable and aluminum connectors with aluminum cable.

Aluminum-to-copper connections must be made with special aluminum connectors designed to run cooler than the copper conductor and compensates for the difference in the coefficient of expansion. These connectors have a larger mass than standard aluminum connectors.

4. Corrosion

- A. **Electrolysis:** The third characteristic of aluminum that affects connectors is not peculiar to aluminum alone but is common to all metals. Aluminum in contact with another metal in the presence of moisture will have an electrolysis action.

This problem exists in the connection of aluminum-to-copper, and the electrolysis action causes corrosion of the anode material (aluminum), leaving the cathodic material (copper) undamaged.

- B. **Chemical:** Moisture in the absence of air reacts with aluminum forming aluminum hydroxide, which, in a very short time, will seriously corrode the aluminum material.

It is of extreme importance that aluminum conductors and connectors installed underground be free of moisture. Special care must be used to prevent moisture from entering into underground splices by using an inhibitor, and carefully and correctly taping or sealing splices.

## Connectors for Insulated Cables Underground Distribution Systems

### 5. General Rules for Battery Presses.

- A. A 6-ton in-line or pistol grip battery-powered press is equivalent to the older mechanical hand tools used for pressing connectors - for example, the Burndy MD6-8 tool.
- B. A 6-ton tool uses the same dies and the same number of compressions that the mechanical hand tool does.
- C. If the connector is stamped with a die designation of HYD, it means a 12-ton tool is necessary with a U die. In the past only 12-ton presses were hydraulic. Examples:
  - A Kearney 303 connector shows “HYD O DIE”. This means a 12-ton tool with a U-O die (with 1 compression) is required. An O die in a 6-ton tool is not sufficient.
  - A Kearney 308 connector shows “HYD D OR D3 DIE”. This means a 12-ton tool with a U-D or U-D3 die (with 1 compression) is required.
- D. If the connector is stamped with a die designation of HAND or MEC, it means a 6-ton tool can be used with a W die. Example:
  - A Kearney 302 connector shows “HYD B – MEC K”. This means a 6-ton tool with a W-KK die (with 3 compressions) can be used or a 12-ton tool with a U-B die (with 1 compression) can be used. The 6-ton tool is much lighter than the 12-ton tool and is preferred for ergonomics.

6. For information on multi-tap splices for 600V insulated cable refer to [Document 036640](#)

7. All information for field drilling connectors has been removed in this revision (16). Use range taking connectors (shearbolt) when dealing with non-standard cable sizes.

8. Ground terminal connector has been replaced with a more robust design. See Table 10 on page 14.

### Application

1. There are four general types of connectors: solder sweated, bolted, compression, and shear-bolt. The advantages, disadvantages, and normal application of these four types of connectors are described in Table 1.
2. Compression tap connectors, Pages 15 through 18, are the preferred connectors for residential and light commercial installations.

**Table 1 UG Connector Comparison**

Connector Type	Application	Advantages	Disadvantages
Solder Sweated Split Tinned Copper <sup>1</sup>	For Copper-to-Copper Straight Connections (Page 13)	<ul style="list-style-type: none"> <li>• Inexpensive</li> <li>• Excellent Electrical Connection</li> </ul>	<ul style="list-style-type: none"> <li>• Special Tool Required</li> <li>• Must Be Sweated on (increasing time and labor)</li> <li>• Limited to Copper Cables</li> </ul>
Bolted	Terminals and Tap Connections Rated Less Than 600 V (Pages 14, 28, 30, 32, and 36 - 37)	<ul style="list-style-type: none"> <li>• Fast and Easy Install</li> <li>• Wide Range of Sizes</li> <li>• No Special Tools Required</li> <li>• Low Cost</li> </ul>	<ul style="list-style-type: none"> <li>• More Difficult to Seal</li> </ul>
Compression (preferred)	Straight and Tap Connections for Copper and Aluminum Cables (Pages 8 - 12, 17 - 27, 33 - 35, and 38)	<ul style="list-style-type: none"> <li>• Preferred Electrical Connection</li> <li>• Ease of Installation</li> </ul>	<ul style="list-style-type: none"> <li>• Requires Specific Tools and Dies</li> </ul>
Shearbolt	Straight and Y & H Cold-Shrink Splices	<ul style="list-style-type: none"> <li>• Range Taking</li> <li>• Excellent Electrical Connection</li> <li>• Ease of Installation</li> <li>• No Special Tool Required</li> </ul>	<ul style="list-style-type: none"> <li>• More Expensive</li> </ul>

1. Use only with paper-insulated lead-covered (PILC) Cable.

## Connectors for Insulated Cables Underground Distribution Systems

References	Location	Document
<a href="#">Joints for 15 kV Three-Conductor Paper-Insulated Lead-Covered Cable for Use on 12 kV Circuits</a>	UG-2: Splices	022709
<a href="#">Method of Terminating 15 kV Paper Insulated Lead-Covered Cable</a>	UG-2: Terminations	022820
<a href="#">Splice for Leaded to Non-Leaded Cable</a>	UG-2: Splices	022824
<a href="#">Splice for 5 kV and 15 kV Type RO&amp;N Cable Single Conductor Shielded</a>	UG-2: Splices	022827
<a href="#">Method of Terminating 5 kV Single Conductor Non-Leaded Rubber-Type Cable</a>	FRO: UG-1 Terminations	022828A
<a href="#">Method of Terminating 15 kV and 22 kV Single Conductor XLPE-PVC and EPR-PVC Cables (compound filled pothead)</a>	FRO: UG-1 Terminations	022829A
<a href="#">Street Light Cable Splices</a>	UG-2: Splices	022830
<a href="#">Method of Terminating Single Conductor Non-Leaded Varnished Cambric Insulated Cables</a>	FRO: UG-1 Terminations	022831A
<a href="#">Splice for Varnished Cambric Insulated Cable With Flameproof Jacket</a>	UG-2: Splices	022832
<a href="#">Installation of Cable Risers on Wood Poles</a>	OH: Risers/UG-1 Terminations	027742
<a href="#">Current Transformers</a>	ELS	028114
<a href="#">Distribution Transformer Requirements for Vault Installation</a>	FRO: UG-2: Transformers	030362B
<a href="#">Installation of Single-Phase 12 kV Pad-Mounted Transformer Underground Residential Areas</a>	FRO: UG-1 Transformers	032768A
<a href="#">Joints for 15 kV &amp; 25 kV Single Conductor Paper Insulated Lead-Covered Cable for Use on 12 kV &amp; 22 kV Circuits</a>	UG-2: Splices	033585
<a href="#">10 Arrangement 12 kV Switch and Bus Cells</a>	ELS	033701
<a href="#">Distribution Transformer Requirements Single-Phase and Three-Phase Overhead-Type</a>	OH: Transformers	034963
<a href="#">Installation of Single-Phase 200 V Pad Mounted Transformer Underground Residential Areas</a>	FRO: Transformers	034978A
<a href="#">Single-Phase, Subsurface, Round Transformers</a>	UG-1: Transformers	035313
<a href="#">Installation of Subsurface, Load-Break, and Dead-Break Primary Junction</a>	UG-1: Switches	035380
<a href="#">Multi-Tap Splice for 600-Volt Insulated Cables</a>	UG-1: Splices	036640
<a href="#">Installation of 200-Amp, Subsurface Sectionalizing Switches</a>	UG-1: Switches	039954
<a href="#">Cables for Underground Distribution</a>	UG-1: Cable	039955
<a href="#">Compression-Type Connectors for Overhead Distribution and Transmission</a>	OH: Conductors	041010
<a href="#">Splices for 15 kV and 22 kV XLP-PVC and EPR-PVC Cable Single-Conductor Shielded</a>	ELS	041583
<a href="#">Termination for 15 and 22 kV XLP-PVC, EPR-PVC, and XLP-CONC-PVC Cables Single Conductor Shielded</a>	ELS	041584
<a href="#">Installation of Live-Front, Low-Profile, Single-Phase, Pad-Mounted Transformers</a>	UG-1: Transformers	042762
<a href="#">Installation of Low Profile Single-Phase 6.9 kV Pad Mounted Transformer Underground Residential Systems</a>	ELS	042765
<a href="#">Installation of Three-Phase, Radial-Style, Pad-Mounted Transformers</a>	UG-1: Transformers	043817
<a href="#">Splices for 15 kV and 22 kV Concentric-Type Cable (PE-CONC, XLP-CONC and XLP-CONC-PVC)</a>	ELS	043901

No 24-16278-102-8am archived December 27, 2023  
 City of Berkeley  
 Rest. Assn v. City of Berkeley


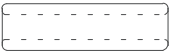




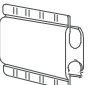

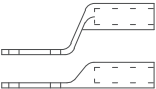
**Connectors for Insulated Cables  
Underground Distribution Systems**

References (continued)	Location	Document
<u>Method of Terminating 15 KV and 22KV I/O &amp; Smaller Concentric Type Cable – XLP-CONC-PVC &amp; XLP-CONC</u> .....	<u>ELS</u> .....	<u>043902</u>
<u>Installation of Loop-Style, Three-Phase, Pad-Mounted Transformers</u> .....	<u>UG-1: Transformers</u> .....	<u>045291</u>
<u>Installation of Three-Phase, 600-Amp, Subsurface Sectionalizing Switches</u> .....	<u>UG-1: Switches</u> .....	<u>050859</u>
<u>Straight and Tap Splice for 600 Volt Insulated Cable</u> ..	<u>UG-1: Splices</u> .....	<u>051034</u>
<u>600-Amp Separable Insulated Connectors</u> .....	<u>UG-1: Terminations</u> .....	<u>051071</u>
<u>Premolded 600-Amp Splices for Primary Underground Cables</u> .....	<u>UG-1: Splices</u> .....	<u>053732</u>
<u>Pad-Mounted Transformers Installed Indoors</u> .....	<u>UG-1: Transformers/Greenbook/EMWP</u> ..	<u>057521</u>
<u>Single-Phase, Dead-Front, and Duplex, Pad-Mounted Transformer Installations</u> .....	<u>UG-1: Transformers</u> .....	<u>064308</u>
<u>Cold Shrink 600-Amp Splices for Primary Underground Cable</u> .....	<u>UG-1: Splices</u> .....	<u>066204</u>
<u>Fired Wedge Connectors for Primary and Secondary Distribution Lines</u> .....	<u>OH: Conductors</u> .....	<u>066194</u>
<u>24 kV 1/0 Cable Joint for Use on 22 kV Circuits, PILC Cables</u> .....	<u>ELS</u> .....	<u>306644</u>
<u>Straight Cold Shrink™ 15 KV Transition Splices</u> .....	<u>ELS</u> .....	<u>072152</u>
<u>Cold-Shrinkable Trifurcating 600-Amp 15KV Transition Splice</u> .....	<u>ELS</u> .....	<u>076245</u>
<u>Cold-Shrinkable Straight 600-Amp 15 KV Transition Splice</u> .....	<u>ELS</u> .....	<u>076246</u>
<u>Medium Voltage Y and H Splices for Manhole Applications</u> .....	<u>UG Splices</u> .....	<u>076261</u>
<u>Grounding of Tape Shield and Flat Strap Neutral Cables</u> .....	<u>UG: General</u> .....	<u>076264</u>

*cited in Cal. Rest. Ass'n v. City of Berkeley  
No. 21-16278am archived December 27, 2023*

## Connectors for Insulated Cables Underground Distribution Systems



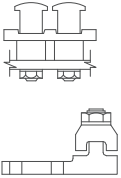
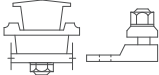
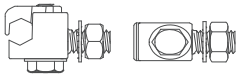
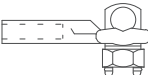
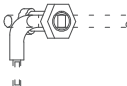
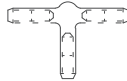
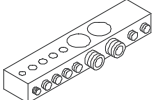
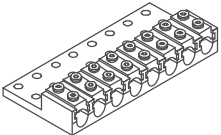
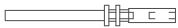
**Table 2 Connectors – Pictorial Index**

Connector	Type		Page	Application	
				Cable	Document <sup>1</sup>
	Straight Connectors	Compression	8 to 9	Copper-to-Aluminum	<a href="#">022824</a> <a href="#">022827</a> <a href="#">022830</a> <a href="#">041583</a> <a href="#">043901</a> <a href="#">051034</a>
			10 & 15	Aluminum-to-Aluminum	<a href="#">022709</a> <a href="#">022824</a> <a href="#">022827</a> <a href="#">022830</a> <a href="#">022832</a> <a href="#">033585</a> <a href="#">041583</a> <a href="#">043901</a> <a href="#">051034</a>
			11 to 13	Copper-to-Copper	<a href="#">066204</a> <a href="#">072152</a> <a href="#">076245</a> <a href="#">076246</a>
		Shearbolt	2	Bi-Metal Copper or Aluminum	<a href="#">022709</a> <a href="#">022824</a> <a href="#">022827</a> <a href="#">022830</a> <a href="#">022832</a> <a href="#">033585</a> <a href="#">041583</a> <a href="#">043901</a> <a href="#">051034</a>
	Split Connectors	Solder	13	Copper-to-Copper	<a href="#">022709</a> <a href="#">022824</a> <a href="#">022827</a> <a href="#">022830</a> <a href="#">022832</a> <a href="#">033585</a> <a href="#">041583</a> <a href="#">043901</a> <a href="#">051034</a>
	Tap Connectors	Bolted	14	Copper-to-Copper (San Francisco and Oakland Network only)	<a href="#">051034</a>
		Compression	15 to 20	Aluminum-to-Aluminum or Aluminum-to-Copper (for secondary conductors)	
			19 to 21	Copper-to-Copper (for secondary conductors)	
	Terminal Connectors		22 to 27	Aluminum-to-Copper (for transformer spade terminals)	<a href="#">032768A</a> <a href="#">034978A</a> <a href="#">042762</a> <a href="#">042765</a> <a href="#">043817</a> <a href="#">045291</a>

<sup>1</sup> For a description of the application document, see “References” on Page 3.

## Connectors for Insulated Cables Underground Distribution Systems

Table 2 Connectors – Pictorial Index (continued)

Connector	Type		Page	Application	
				Cable	Document <sup>1</sup>
	Terminal	Compression	4	Bi-Metal Copper or Aluminum	<a href="#">051071</a>
		Shearbolt	4		<a href="#">076261</a>
	Terminal Connectors	Bolted	28 to 31	Copper (for transformer spade terminals, non-preferred)	<a href="#">028114</a> <a href="#">030362B</a> <a href="#">033701</a>
	Terminal Connectors	Bolted	32	Copper (transformer terminals)	<a href="#">028114</a> <a href="#">030362B</a> <a href="#">033701</a>
	Ground Terminal	Bolted	14	Copper (equipment tank grounds and primary concrete enclosures)	<a href="#">035313</a> <a href="#">035380</a> <a href="#">039954</a> <a href="#">050859</a>
	Tap Connectors	Bolted	32	Copper-to-Copper	<a href="#">022828A</a> <a href="#">022829A</a> <a href="#">022831A</a>
			32	Copper-to-Aluminum	<a href="#">042762</a> <a href="#">042765</a>
			Compression	33	Aluminum-to-Aluminum Copper-to-Aluminum Copper-to-Copper
	Slip-Fit Connectors	Bolted	36	Aluminum or Copper	<a href="#">064308</a>
	Multiple Transformer Terminal	Bolted	37	Aluminum or Copper	<a href="#">043817</a> <a href="#">045291</a>
	Pin Terminals	Compression	38 – 39	Aluminum or Copper	<a href="#">027742</a> <a href="#">041584</a> <a href="#">043902</a>
Tool and Die Information	Compression	7	Copper Cables Aluminum Cables	-	
		8			

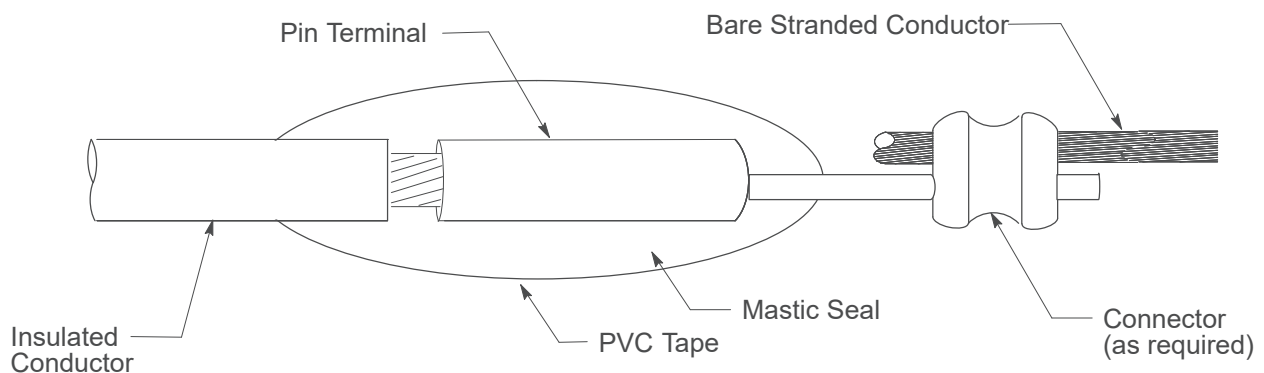
<sup>1</sup> For a description of the application document, see "References" on Page 3.

## Connectors for Insulated Cables Underground Distribution Systems

### Applications of Straight Connectors Compression-Type (copper-to-aluminum)

#### Notes

1. Circular dies should be used on all primary and secondary splices. In these small sizes, the indent-type dies seriously distort the connector.
2. Tool index numbers may be applied to in-line cable-to-cable limiters.
3. For the correct number of crimps, see the appropriate numbered document or the manufacturer's instructions on the package. When the information is not available, make as many non-overlapping crimps as possible without going over the outer end.
4. Pages 8 through 14 and 17 through 22 show compression-type connectors used to connect copper conductors to aluminum conductors. These connectors may also be used to connect aluminum-to-aluminum conductors.
5. Table 3 on Page 8 and Table 4 on Page 9 show compression splice connectors which accommodate specific conductor sizes.
6. Use a clean wire brush to remove oxides from the conductors prior to installing the connectors.
7. After the connector has been pressed on, insulating and sealing of pressed connections is accomplished in the same manner as shown in [Document 051034](#). Special attention must be given to the following:
  - A. Both ends of the aluminum connector should contain oxide inhibitor. Connectors shown in Table 3 on Page 8 and Table 4 on Page 9 are prefilled with inhibitor. See [Document 028852](#) for approved oxide inhibitors.
  - B. After the connector has been pressed on the cable, excess oxide inhibitor must be wiped from the connector and conductor surface.
  - C. Use special care to ensure a moisture-proof splice.
8. Solder-type connectors must not be used on aluminum conductors. This type of connection is only allowed on PILC cable.
9. If several insulated aluminum conductors are to be connected to one insulated copper conductor, each aluminum conductor must first be spliced to a short length of copper conductor so that the multiple connection can be made with all copper conductors. This multiple connection may be a tee tap (or several tee taps) as shown in [Document 051034](#).
10. Special care must be used to prevent moisture from entering through the copper strands when connecting a bare stranded copper conductor to an insulated aluminum conductor (e.g., copper-to-aluminum neutral connection). See Figure 1 below for these connections.

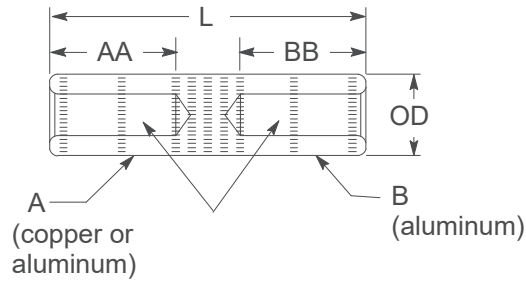


**Figure 1**  
**Connection Between Bare and Insulated Conductor**

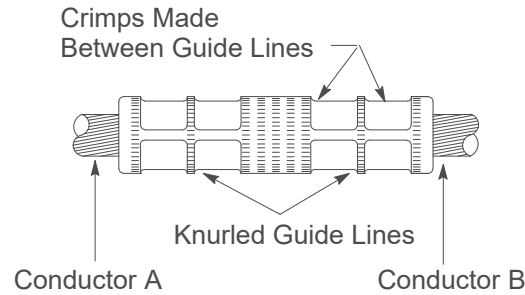


## Connectors for Insulated Cables Underground Distribution Systems

### Straight Connectors Compression-Type (predrilled) Copper-to-Aluminum



**Figure 2**  
Overall Dimensions



**Figure 3**  
View After Connector Installation  
(for Figure 2)

**Table 3 Compression-Type Connectors – Predrilled**

Conductor Size – AWG or kcmil		Connector Dimensions (inches)				Manufacturer and Catalog Numbers			6-Ton Tool Die # <sup>5</sup> 12-Ton Tool Die # 15-Ton Tool Die #	Connector Code
A <sup>1</sup> (Cu or Al)	B (Al)	AA	BB	L <sup>2</sup>	OD	Burdny	Richards	Homac		
4	2	1.03	1.03	2.75	0.65	See <a href="#">Document 028852</a>			W-BG U-BG U-BG <sup>4</sup>	305558 <sup>3</sup>
2	2					YR1CA2CCAG1	ALCR 8-7	SAC1R2		305559 <sup>3</sup>
2	1					See <a href="#">Document 028852</a>				305569
2	1/0					YR26A2CCAG1	ALCR 10-7	SAC2/0 R2		305562 <sup>3</sup>
2	2/0	1.56	1.56	4.00	0.91	YS26UG2	ALC 10	SAC2/0	W249 U249 U249 <sup>4</sup>	305571
2/0	2/0					YR27A26CAG1	ALCR 11-10	SAC3/0 R2/0		305581
2/0	3/0					YR28A26CAG1	ALCR 12-10	SAC4/0 R2/0		305582
2/0	4/0									305585

<sup>1</sup> Maximum copper conductor size.

<sup>2</sup> These dimensions may vary slightly among the various suppliers.

<sup>3</sup> These connectors are overhead-type insulated service sleeves. The insulation on these sleeves does not provide an adequate seal for underground application. These sleeves must be insulated and sealed as shown in [Document 051034](#) as if they were bare.

<sup>4</sup> A U-die adapter must be used when utilizing U-dies in a 15-Ton press.

<sup>5</sup> Within this column, the first entry corresponds to a 6-ton press tool, the second entry corresponds to a 12-ton press tool, and the third entry corresponds to a 15-ton press tool.

## Connectors for Insulated Cables Underground Distribution Systems

### Straight Connectors Compression-Type (predrilled) Copper-to-Aluminum (continued)

**Table 4 Compression-Type Connectors – Predrilled**

Conductor Size – AWG or kcmil		Dimensions (inches)				Manufacturer and Catalog Numbers			6-Ton Tool-Die # <sup>4</sup> 12-Ton Tool Die # 15-Ton Tool Die #	Connect- or Code
A <sup>1</sup> (Cu or Al)	B (Al)	AA	BB	L <sup>2</sup>	OD	Burdny	Richards	Homac		
250	250	1.86	1.86	4.62	1.12	YS29UG1	ALC 13	SACB250	– U31ART U31ART <sup>3</sup>	305586
250	300					YR30A29CAG1	ALCR 14-13	SAC300R250		305602
250	350					YR31A29CA	ALCR 15-13	SAC350R250		305127
250	400	2.55	2.55	6.19	1.62	YR32A29CAG1	ALCR 16–13	SACL400R250	– UI39ART P39ART	305604
500/600	500					YS34APGE	ALC 18	SACL500		305108
500	600					YR36A34CA	ALCR 20-18	SAC600R500		305129
500	700, 750					YR39A34CA	ALCR 25-18	SAC750R500		305107
500	800	2.91	2.91	7.16	1.84	YR40A34CAG1	ALCR 24-18	SACF800R500	– – P44ART	305606
750	1,000					YR44AG3	ALCR 28-23	SAC1000R750		305023
<b>For Circuits Above 5 kV</b>										
4	2	1.50	1.50	3.57	0.65	YR2CA4CCATG1	OATCR7-7	SAC2R4	W-BG U-BG U-BG <sup>3</sup>	305607
2	2					YS2CUTG1	OATC 7	SAC2		305608
2	1/0					YR25A2CCATG3	OATCR9-7	SAC1/0R2		305609
2/0	4/0	2.08	2.08	4.82	0.91	YR2BA26CATG2	OATC 12-10	SAC4/0R2/0	W249 U249 U249 <sup>3</sup>	305610
250	350	2.61	2.96	6.66	1.12	YR31A29CAT	OATC15-13	SAC350R250	– U31ART U31ART <sup>3</sup>	305143
500/600	700, 750	3.75	4.19	9.41	1.62	YR39A34CAT	OATC23-18	SAC750R500	– U39ART P39ART	305403
750	1,000	4.10	4.10	9.09	1.84	YR44ATG1	OATC28-13	SAC1000R750	– – P44ART	305611

<sup>1</sup> Maximum copper conductor size.

<sup>2</sup> These dimensions may vary slightly among the various suppliers.

<sup>3</sup> A U-die adapter must be used when utilizing U-dies in a 15-Ton press tool.

<sup>4</sup> Within this column, the first entry corresponds to a 6-ton press tool, the second entry corresponds to a 12-ton press tool, and the third entry corresponds to a 15-ton press tool.

#### Notes

- Connectors shall be pre-filled with an approved oxide inhibitor.
- All connectors shall have an oil stop.

### Connectors for Insulated Cables Underground Distribution Systems

#### Straight Connectors Compression-Type (aluminum-to-aluminum)

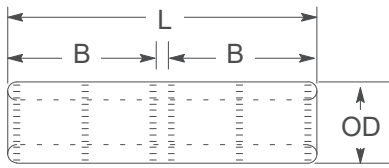


Figure 4

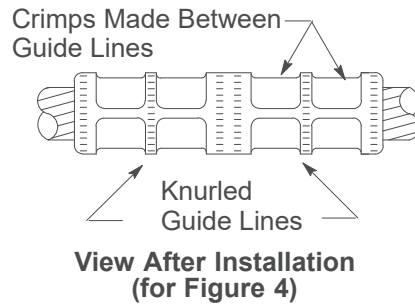


Table 5 Dimensions and Ordering Information – Aluminum-to-Aluminum (Figure 4)

Conductor Size AWG or kcmil	Refer to	Dimensions (inches)			Manufacturer and Catalog Number			6-Ton Tool Die # <sup>4</sup> 12-Ton Tool Die # 15-Ton Tool Die #	Code
		L	B	OD	Burndy	Richards	Homac		
2	Figure 5 On Page 11	2.75	1.18	0.65	See <a href="#">Document 028852</a>			W-BG	305559 <sup>1</sup>
1/0		2.75	1.18	0.65				U-BG U-BG <sup>3</sup>	305563 <sup>1</sup>
4/0		3.30 <sup>2</sup>	1.54 <sup>2</sup>	0.91	YS28AG9	ALC12	AC410	W249 U249 U249 <sup>3</sup>	305616
350		6.97	3.38	1.12	YS31AY	ALC15	AC350	U31ART U31ART <sup>3</sup>	305148
700/750		8.28	4.00	1.62	YS39AY	ALC23	AC750	U39ART P39ART	305150
1,000		10.81	5.25	1.84	YS44AY	ALC28	AC1000	P44ART	305618

*cited in Cal. Rest. Ass'n v. City of Berkeley  
No. 21-16278am archived December 27, 2023*

<sup>1</sup> These connectors are overhead-type insulated service sleeves (see [Document 028852](#)). The insulation on these sleeves will not provide an adequate seal for underground application. These sleeves must be insulated and sealed as shown in [Document 051034](#) as if they were bare.

<sup>2</sup> For Burndy & Richards, Dimension L = 2.34", B = 1.09".

<sup>3</sup> A U-die adapter must be used when utilizing u-dies with 15-Ton press.

<sup>4</sup> Within this column, the first entry corresponds to a 6-ton press tool, the second entry corresponds to a 12-ton press tool, and the third entry corresponds to a 15-ton press tool

#### Notes

- Connectors shall be pre-filled with an oxide inhibitor.
- Connectors shown in Table 5 above are not suitable substitutes for the compression connectors supplied in the 3M pre-molded splice kits. The connector ODs supplied in the splice kits are larger than normal to provide a heat sink and facilitate sliding the pre-molded housing back and forth.
- These connectors are aluminum unplated finished and must be used only with aluminum cables.

## Connectors for Insulated Cables Underground Distribution Systems

### Straight Connectors Compression-Type (copper-to-copper)

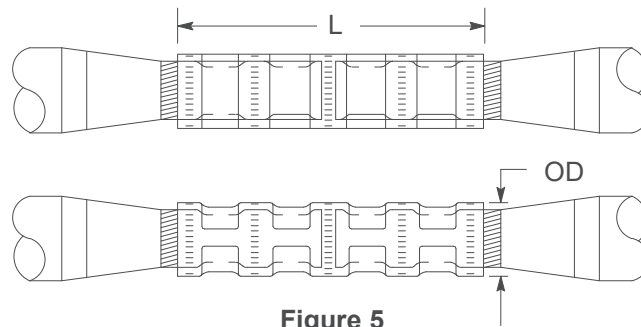


Figure 5

**Table 6 Straight Connectors – Compression-Type – Copper-to-Copper (Figure 4)**

Conductor Size AWG or kcmil	Dimensions (inches)		Manufacturer and Catalog Number				6-Ton Tool Die # <sup>4</sup> 12-Ton Tool Die # 15-Ton Tool Die #	Code
	Length (L)	OD	Burndy	Richards	Homac	Dossert		
4	2.38	0.34	YSP4CT	OCC5	PC-4	DPCP 4	W4CRT U4CRT U4CRT <sup>3</sup>	305164 <sup>1</sup>
2 <sup>2</sup>	2.62	0.42	YSP2CT	OCC7	PC-2	DPCP 6	W2CRT U2CRT UWCRT <sup>3</sup>	305165 <sup>1</sup>
2/0	2.21	0.56	YS26T	CC10	TC-20	DPC 13-T	W26RT U26RT U26RT <sup>3</sup>	305283
2/0	3.13	0.56	YSP26T	OCC10	PC-2/0	DPCP 13	U26RT <sup>3</sup>	305167 <sup>1</sup>
4/0	2.39	0.69	YS28T	CC12	C-4/0	DPC 21-T	W28RT U28RT U28RT <sup>3</sup>	305285
250	3.38	0.75	YSP29T	OCC13	PC-250	DPCP 25	– U29RT U29RT <sup>3</sup>	305429 <sup>1</sup>
250	3.38	0.75	YS29	CC13	C-250	DPC 25	U29RT <sup>3</sup>	305202
500	4.62	1.06	YSP34T	OCC18	PC-500	DPCP 50	– U34RT U34RT <sup>3</sup>	305428 <sup>1</sup>
500	4.63	1.06	YS34	CC18	C-500	DPC 50	U34RT <sup>3</sup>	305203
750	4.23	1.3	Y39T	CC23	TC-750	DPC 75-T	– U39RT U39RT <sup>3</sup>	305488
1,000	6.13	1.50	YS44	CC28	C-1000	DPC 100	– – P44RT	305480
1,500	6.5	1.84	YS46	CC30	C-1500	DPC 150	– – P46RT	305511

<sup>1</sup> These connectors have oil stops. These are more costly connectors and should only be used for splicing P&L cable to rubber or polyethylene insulated cables.

<sup>2</sup> For #2 Solid, use Burndy 162 die index. Refer to Table 20 on Page 19 for Die ordering information.

<sup>3</sup> A U-die adapter must be used when utilizing u-dies with 15-Ton press.

<sup>4</sup> Within this column, the first entry corresponds to a 6-ton press tool, the second entry corresponds to a 12-ton press tool, and the third entry corresponds to a 15-ton press tool.

**Connectors for Insulated Cables  
Underground Distribution Systems**

---

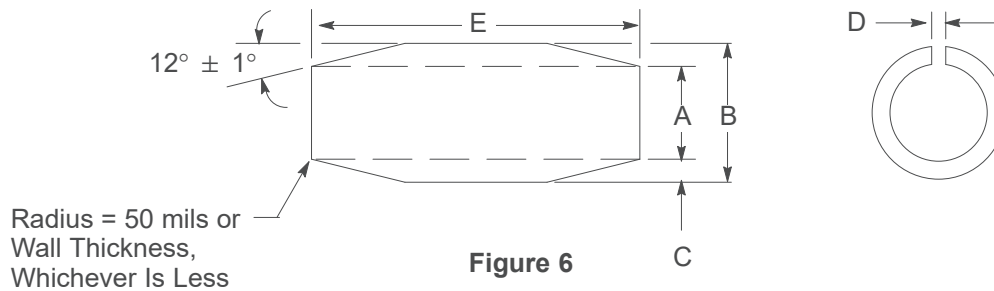
***Straight Connectors Compression-Type (copper-to-copper)(continued)*****Notes**

1. For material and finish information refer to "Specifications for Straight Compression Type Connectors for Insulated Copper Conductors".
2. Connectors shown in Figure 5 on Page 11 are to be used to connect cables of up to 35 kV rating or lower, and can be used on bare cables where such cables will not be subjected to tension.
3. An indentor type compression die (clacker) should not be used on #4 or #2 AWG size connectors because it excessively distorts the connector.
4. Round the sector cable with rounder tool.

*cited in Cal. Rest. Ass'n v. City of Berkeley  
No. 21-16278am archived December 27, 2023*

## Connectors for Insulated Cables Underground Distribution Systems

### Straight Connectors Solder-Type (copper-to-copper)



**Table 7 Straight Connectors – Split Tinned-Type – Copper-to-Copper, All Voltages (Figure 6)**

Cable Size AWG or Kcmil (round or compact sector)	Nominal Dimensions – Inches					Standard Package	Bumdy Part Number	Richards	Code
	A ID	B OD	C (wall thickness)	D (slot width)	E (length)				
8	5/32	3/16	1/32	1/32	1-1/2	200	SS8C8C	RSS2	305041
6	3/16	1/4	1/32	1/32	1-1/2	200	SS6C6C	RSS3	305042
4	7/32	5/16	1/32	1/32	2	100	SS4C4C	RSS5	305043
2	9/32	3/8	1/32	1/32	2	100	SS2C2C	RSS7	305044
1/0	3/8	1/2	1/16	1/16	2	100	SS2525	RSS9	305045
2/0	13/32	9/16	1/16	1/16	2	100	SS2626	RSS10	305046
3/0	15/32	5/8	1/16	1/16	2	100	SS2727	RSS11	305059
4/0	17/32	23/32	1/16	1/16	2-1/2	30	SS2828	RSS12	305047
250	9/16	25/32	3/32	1/8	2-1/2	50	SS2929	RSS13	305048
350	11/16	29/32	3/32	1/8	2-1/2	20	SS3131	RSS15	305324
400	23/32	31/32	1/8	1/8	3	10	SS3232	RSS16	305049
500	13/16	1-3/32	1/8	1/8	3	10	SS3434	RSS18	305050
600	29/32	1-3/16	1/8	5/32	3-1/2	10	SS3636	RSS20	305051
750	1-1/32	1-11/32	5/32	5/32	3-1/2	10	SS3939	RSS23	305052
1,000	1-5/32	1-9/16	3/16	7/32	4-1/2	1	SS4444	RSS28	305053
1,500	1-7/16	1-29/32	7/32	9/32	5	1	SS4646	RSS30	305054
2,000	1-21/32	2-7/32	1/4	9/32	6	1	SS4848	RSS32	305055

#### Notes

- For material and finish refer to "Edison Electric Institute Specification TD 160 "Specifications for Solder-Sweated Split Tinned Copper Connectors".
- When splicing cables of different sizes, cut a sector from one half of the connector.
- When tinning and sweating the connector onto the conductors:
  - Protect the insulation.
  - Wipe smooth, removing all sharp solder points.
- Round the sector cable with a rounder tool.

#### Application

These connectors must be used only to tap splices 5,000 V and above on copper cable in sizes larger than #2 AWG.

### Connectors for Insulated Cables Underground Distribution Systems

#### Bolted Connectors for Underground Network Systems

A. These copper alloy connectors are for making copper-to-copper current carrying connections on underground network secondary systems in San Francisco and Oakland.

**Table 8 Split Bolt Connectors For Copper-to-Copper Connections (Figure 7)**

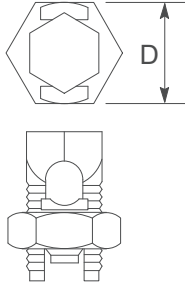


Figure 7

Conductor Size AWG or kcmil		Nut Size D	Torque Inch-lbs. (ft./ lbs)	Code	Manufacturer and Catalog Number			
Solid	Stranded				Blackburn	Burndy	Penn-Union	Homac
10	10	7/16"	80 (7)	305026	9H	KS90	S-10-S	-
8	8	1/2"	80 (7)	305027	8H	KS15	S-8-S	E-8
6	8	11/16"	-	305028	6H	KS17	S-6-PGE	E-6
4	6	3/4"	-	305029	4H	KS20	S-4-PGE	E-4
2	4	7/8"	-	305030	2H	KS22	S-3-PGE	E-2
1	2	7/8"	-	305031	1H	KS23	S-2-S	-
2/0	1/0	1"	-	305032	10H	KS25	S-1/0-S	E-1/0
3/0	2/0	1-1/18"	385 (32)	305033	20H	KS26	S-2/0-S	E-2/0
4/0	3/0, 4/0, 250	1-5/16"	650 (54)	305034	40H	KS29	S-250-PGE	E-250

**Table 9 Two Bolt Connectors for Copper-to-Copper Connections (Figure 8)**

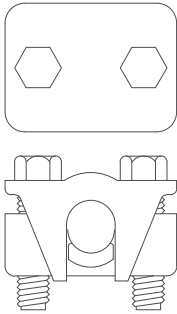


Figure 8

Conductor Size AWG or kcmil		Code	Manufacturer and Catalog Number					
Main Run	Min. Tap		Hubbell	Blackburn	Burndy	Penn-Union	AFL	Homac
4/0	6	305431	K-3	2B40	KVS28	VT-2	DSU21	-
250 to 350	1/0	305432	K-4	2B350	KVS31	VT-3	DSU35	TBC 350
400 to 500	2/0	305433	K-5	2B500	KVS34	VT-4	DSU50	TBC 500
600 to 750	4/0	305434	K-6	2B800	KVS40	VT-5	DSU80	TBC 800
800 to 1,000	4/0	305435	K-7	2B1000	KVS44	VT-6	DSU1000	TBC 1000

**Notes**

1. Connectors shown in Table 8 and Table 9 are for use on unshielded insulated cables rated 600 V or lower.
2. Connectors shown in Table 8 may also be used to connect unshielded streetlighting cable.
3. If necessary, double back on small size tap wires to obtain a tight fit.
4. The connectors described on this page can be used on bare cables where such cables will not be subjected to tension.
5. These connectors shall not be used in overhead applications.

**Ground Terminal**

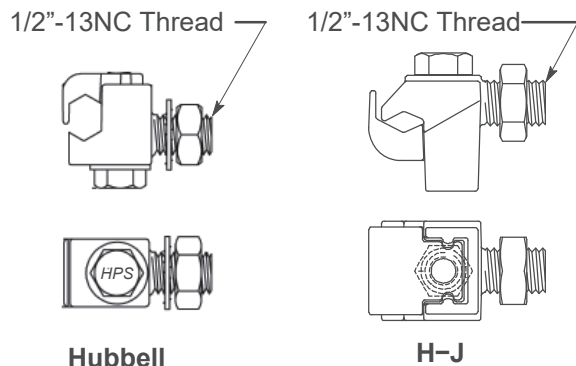


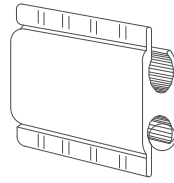
Figure 9

**Table 10 Ground Terminal (Figure 9)**

Conductor Size AWG	Manufacturer and Catalog Number		Code
	Hubbell	H - J	
#4 Str. - 2/0	GC-208	AS1372-002	M301546

**Connectors for Insulated Cables  
Underground Distribution Systems**

**Tap Connectors Compression-Type (#6 through 400 kcmil aluminum-to-aluminum or aluminum-to-copper)**



**Figure 10  
H-Type Connector**

**Table 11 Tap Connectors – Compression-Type – Aluminum-to-Aluminum or Aluminum-to-Copper (Figure 10) <sup>1</sup>**

Conductor Size AWG or kcmil	Tap																	
	#6 Sol.	#4 Sol.	#4 Str.	#2 Sol.	#1 Sol.	#2 Str.	1/0 Sol.	1/0 Str.	2/0 Str.	3/0 Str.	4/0 Str.	250	266.8 Str.	336.4 Str.	350	397.5	400	
Run	#6 Sol.	Code 305507			-			-			-							
	#4 Sol.																	
	#4 Str.																	
	#2 Sol.																	
	#1 Sol.	Code 305509						-			-							
	#2 Str.																	
	1/0 Sol.																	
	1/0 Str.																	
	2/0 Str.	Code 305510			Code 305519			Code 305831										
	3/0 Str.																	
	4/0 Str.	Code 305520			Code 305830			Code 305833										
	250										Code 305832							
266.8 Str.																		
336.4 Str.																		
350																		
397.5																		
Run	400	Code 305832						Code 305833			Code 305834							

*cited in Cal. Rest. Ass'n v. City of Berkeley  
No. 21-16278am archived December 27, 2023*

<sup>1</sup> For required number of compressions, Refer to Table 13 on Page 16.

**Table 12 Aluminum Compression Connectors for Secondary Connections to Streetlight Conductors**

Conductor Size (AWG)		Tap	
		#10 Sol.	#8 Sol.
Run	#2 Str.	Code 305842	
	1/0 Str.		
	2/0 Str.		
	3/0 Str.	Code 305843	
	4/0 Str.		



## Connectors for Insulated Cables Underground Distribution Systems

### Tap Connectors Compression-Type (#6 through 400 kcmil aluminum-to-aluminum or aluminum-to-copper) (continued)

**Note**

The material for these connectors is aluminum alloy.

**Application**

These connectors are used for straight splice or tap, residential and light commercial.

**Table 13 Aluminum H-Type Compression Connectors**

Tools and Dies Data				
Connector Code 1	6-Ton Tool		12-Ton Tool	
	Die	Required # of Compressions	Die	Required # of Compressions
305507	W-O	4	U-O	2
305509		5 <sup>1</sup>		
305510	W-D	5 <sup>1</sup>	U-D	2
305519				
305520				
305830		7		3
305831	-	-	U-N	2
305832				3
305833				2
305834				3
Connectors for Connection to Secondary Streetlight Conductors				
305842	W-O	4	U-O	2
305843	W-D	4	-	-

<sup>1</sup> These connectors are the same tap connectors shown in [Document 041010](#).

**Note**

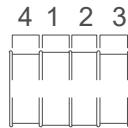
1. Do not use the N Die with UT-15 tools
2. Use U-die adapter with U-dies when a 15-ton press tool is utilized.

## Connectors for Insulated Cables Underground Distribution Systems

### Tap Connectors Compression-Type for Secondary Conductors (2/0 through 1000 kcmil aluminum-to-aluminum or aluminum-to-copper)

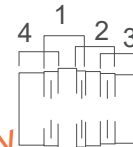
**Table 14 Tap Connectors – Compression-Type for Secondary Conductors**

Conductor Size AWG or kcmil	Tap														
	2/0	3/0	4/0	250	268.8	300	397.5	500	600	636	700	715.5	750	900	1000
Run	397.5	See Table 11 Page 15						Code 305522		-					
	500	Code 305521						Code 305522		-					
	600	Code 305521						Code 305522		-					
	636	Code 305524						Code 305526		Code 305537					
	700	Code 305524						Code 305526		Code 305537					
	715.5	Code 305524						Code 305526		Code 305537					
	750	Code 305524						Code 305526		Code 305537					
	900	Code 305524						Code 305526		Code 305537					
1,000	Code 305804		Code 305875			Code 305976					Code 305538				



Marking on Connector for Compression with R Die

**Figure 11**  
Order of Compression Sequence



Position of Z Die on R Die Compression Markings

**Figure 12**  
Installation Instructions for Z Die

**Table 15 Ordering Data for Z Die for Use in UT-15 Hydraulic Tool**

Die Designation	Code	Manufacturer and Catalog Number
Z	216248	Homac 15 CZ <sup>1</sup>

<sup>1</sup> T&B equivalent 15620.

#### Notes

- The material of these connectors is aluminum alloy.
- Two dies can be used for compressing the aluminum H-Type connectors listed in above Table 14. These are the R and Z dies. Some manufacturers refer to both dies while others designate only the R die on their connectors. Homac, the supplier of the UT-15 hydraulic head, has standardized on the Z die. Since this tool is standard on the System, the Homac Z die catalog number 15 CZ, has been specified for use in the UT-15 head for compressing all connectors listed in above Table 14. The Z die is slightly wider than the R die and will overlap the R die guide markings on the connectors.
- When using the Z die on connectors which require three compressions, make the first compression in the center. The Z die will overlap the crimp location markings on the connector since these markings are based on the narrower R die. Then make a compression on each side of the center compression, keeping the die even with the outside edge of the connector and overlapping the previously made center compression.  
  
When using the Z die on connectors which require four compressions, make the first two compressions in the center portion of the connector, overlapping the centerline of the connector on each compression as shown in Figure 12. Then complete a compression on each end, overlapping the previously completed center compression sufficiently to maintain the outer edge of the die flush with the end of the conductor.

#### Application

These connectors are used for straight splice or tap, residential and light commercial.

Connectors for Insulated Cables  
Underground Distribution Systems

Tap Connectors Compression-Type for Secondary Conductors (copper-to-copper)

Table 16 YP-C-Tap (Figure-6 Type) (Figure 13) Copper Connectors



Figure 13  
Burndy YP-C-Tap Type

Conductor Size AWG or kcmil		Tap										
		#6 Sol.	#4 Sol.	#4 Str.	#2 Sol.	#1 Sol.	#2 Str.	1/0 Sol.	1/0 Str.	2/0 Str.	3/0 Str.	4/0 Str.
Run	#6 Sol.	Code 305844						-			Code 012086	
	#4 Sol.											
	#4 Str.											
	#2 Sol.											
	#1 Sol.											
	#2 Str.											
	1/0 Sol.	Code 305845						-			-	
	1/0 Str.											
	2/0 Str.											
	3/0 Str.											
	4/0 Str.											
	250											

Table 17 Die Information for YP-C (Figure-6 Type) Connectors (Figure 13)

Manufacture and Catalog Numbers		Die 1, 2	Connector Code	Required Number of Compressions
Brundy	Dossert	Die U-D		
YP2C2	DC6	U-D	305844	1
YP29C26	DC25-13	U-D3	305845	1
YP28C28	-	U-D3	012086	1

<sup>1</sup> These dies use a 12-ton press tool.  
<sup>2</sup> Refer to Table 24 on Page 21 for Die ordering information.

## Connectors for Insulated Cables Underground Distribution Systems

### Tap Connectors Compression Type for Secondary Conductors (copper-to-copper) (continued)

**Table 18 Blackburn, Homac, Kearney and Penn-Union H-Tap  
Copper Connectors (Figure 14)**



**Figure 14  
Blackburn, Kearney,  
Homac, Penn-Union  
H-Tap Type**

Conductor Size AWG or kcmil	Tap										
	#6 Sol.	#4 Sol.	#4 Str.	#2 Sol.	#1 Sol.	#2 Str.	1/0 Sol.	1/0 Str.	2/0 Str.	3/0 Str.	4/0 Str.
Run	#6 Sol.	Code 305243									
	#4 Sol.										
	#4 Str.	Code 305244									
	#2 Sol.										
	#1 Sol.										
	#2 Str.	Code 305245				Code 305246					
	1/0 Sol.										
	1/0 Str.										
	2/0 Str.										
	3/0 Str.			Code 3052147 <sup>1</sup>				Code 305249		Code 305846	
4/0 Str.	-										

<sup>1</sup> Only the Kearney connector is currently approved for use with #6 solid using a U-D die.

**Table 19 Blackburn, Kearney, and Penn-Union Connectors**

Connector Code	Blackburn Part No.	Kearney Part No.	Die	6-Ton Tool		12-Ton Tool	
				Required Number of Compressions	Die	Required Number of Compressions	Die
305243 <sup>1</sup>	CF-44-1	301-82	W-KB	3	-	-	-
305244 <sup>1</sup>	CF-22-1	302-82	W-KK	3	-	-	-
305245	CF-102-1	304-82	-	-	U-O	1	
305246	CF-1010-1	303-82	-	-	U-O	1	
305247 <sup>1</sup>	CF-402-1	309-82	-	-	U-D	1	
305249	CF-4010-1	308-82	-	-	U-D, D3	1	
305846	CF-4040-1	307-82	-	-	U-D, D3	1	

<sup>1</sup> Do not use with W-BG die for the connectors under M305243 and M305244 codes.

<sup>2</sup> Only the Kearney connector is currently approved for use with #6 solid using a U-D die.

**Table 20 Ordering Data for 6-Ton Press Tool**

Burndy Catalog Number	Die Code <sup>1</sup>	Burndy Catalog Number	Die Code <sup>2</sup>
W-KB	202240	-	-
W-KK	202241	-	-
W-161	1208088	U-161	2791549
W-162	1208089	U-162	2702336
W-163	1208100	U-163	2755406

<sup>1</sup> These dies use 6-ton press tool.

<sup>2</sup> These dies use 12-ton press tool.

<sup>3</sup> These dies are only available for purchase in SRM. The codes shown on this table are the SRM part number.

#### Notes

The material for connectors are on Pages 20 and 21 is copper alloy

## Connectors for Insulated Cables Underground Distribution Systems

### Application

Connectors are on Pages 20 and 21 are used for straight splice or tap.

### Connectors for Splicing and Tapping Concentric Wires

**Table 21 For Splicing and Tapping of XLP-Conc-PVC Cable Concentric Neutrals <sup>2</sup>**

Primary Cable Size AWG or kcmil <a href="#">Document 039955</a> <sup>1</sup>	2/0 Cu 1/0 Al 4/0 Al	350 Al	#2 Al	#4 Cu 250 Cu	#2 Cu	700 Al	500 Cu	1,000 Al
Conc. Size	8 - #14	9 - #14	10 - #14	11 - #14	17 - #14	18 - #14	13 - #12	16 - #12
2/0 Cu 1/0 Al 4/0 Al	8 - #14	Code 305244		Code 305245	Code 305246			Code 305247
350 Al	9 - #14							
#2 Al	10 - #14	Code 305245		Code 305246			Code 305247	
#4 Cu 250 Cu	11 - #14							
#2 Cu	17 - #14	Code 305244		Code 305246			Code 305247	
700 Al	18 - #14							
500 Cu	13 - #12	Code 305247		Code 305246			Code 305247	
1,000 Al	16 - #12							
-	#2 Str. Cu	Code 305245		Code 305246			Code 305249	
-	#2 Solid Cu	Code 305244		Code 305246			Code 305247	

<sup>1</sup> For extension or splicing out of concentric neutral wires, see [Document 051071](#) or [Document 066204](#).

<sup>2</sup> This cable design is no longer approved for purchase.

**Table 22 Connectors for Splicing and Tapping EPR Cable Concentric Neutrals <sup>1</sup>**

Primary Cable Size AWG or kcmil <a href="#">Document 039955</a> <sup>2</sup> (AL)	#2 1/0 600	Concentric Size	#2 1/0 600	1,100
#2	1/0	10-#14	10-#14	12-#14
600	600	10-#14	Code 305244	Code 305245
1,100		12-#14	Code 305245	

<sup>1</sup> This cable design is our current standard.

<sup>2</sup> For extension or splicing out of concentric neutral wires, see [Document 051071](#) or [Document 066204](#).

**Table 23 Connectors for Splicing and Tapping EPR-Cable Flat Strap Neutral <sup>1</sup>**

Primary Cable Size AWG or kcmil <a href="#">Document 039955</a> <sup>2</sup> (Cu)	#2	350 500	750
#2	305244	305246	-
350	-		
500	-	-	-
700	-	-	305247

<sup>1</sup> This cable design is used in special application.

<sup>2</sup> For extension or splicing out of concentric neutral wires, see [Document 051071](#) or [Document 076264](#).

## Connectors for Insulated Cables Underground Distribution Systems

### Connectors for Splicing and Tapping Concentric Wires (continued)

**Table 24 Dies Ordering Data for 12-Ton Press Tool**

Die	Kearney Catalog Number	Burndy Catalog Number	Die Code <sup>1, 2</sup>
U-O	-	U-O	216083
U-D	-	U-D	2811758
U-D3	-	U-D3	216084
U-N	-	UN-C	216085
U-BKT	36832	U-KBKTT	216133

<sup>1</sup> Code includes one complete set of dies consisting of two half-sections.

<sup>2</sup> These dies are only available for purchase in SRM. The codes shown on this table are the SRM part number.

**Table 25 Equivalent Conductor Size for Concentric Neutrals <sup>1</sup>**

Equivalent Size	Concentric Size
#4 Approximate	8 - #14
	9 - #14
	10 - #14
#2 Approximate	11 - #14
	12 - #14
	17 - #14
1/0 Approximate	18 - #14
	15 - #12
	16 - #12

<sup>1</sup> To connect these concentric conductors to conductors other than #2, use the equivalent conductor size and select a connector from Table 21 - 25 on Page 20.

### Connectors for Insulated Cables Underground Distribution Systems

#### Terminal Connectors Compression-Type (aluminum cable for flat bar or transformer spade terminals)

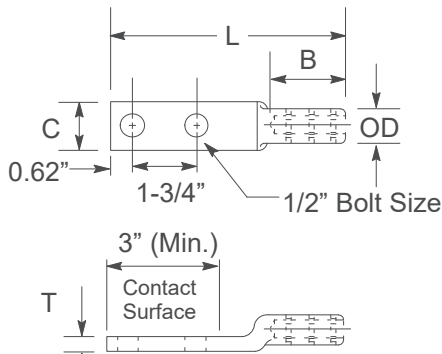


Figure 15  
Straight Terminal

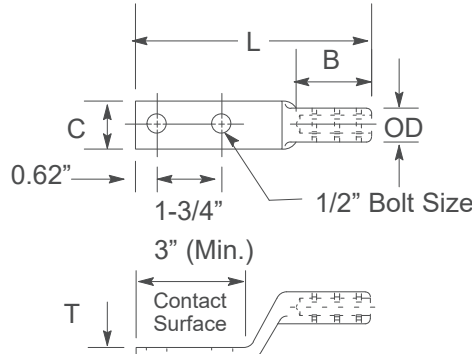


Figure 16  
Stacking Terminal

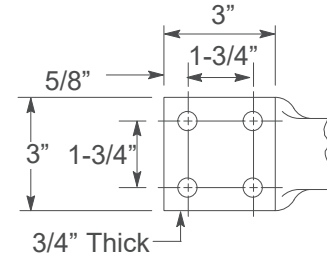


Figure 17  
4-Hole Pad

Table 26 Specifications for Terminal Connectors – Aluminum Cable-to-Flat Bar (Figure 15 and Figure 16)

Cable Size AWG or kcmil	Refer to	Approved for Purchase					Connector Code	6-Ton Tool Dies # <sup>7</sup> 12-Ton Tool Dies # 15-Ton Tool Dies #
		Approximate Dimensions (inches)						
		B	C <sup>1</sup>	L <sup>1</sup>	T <sup>1</sup>	OD		
4	Figure 15	1.24	1.25	4.92	0.25	0.65	303829	W-BG
2		1.10	0.91	5.62	0.25	0.65	303761	U-BG
1/0		1.10	0.91	5.62	0.25	0.65	303760	U-BG <sup>8</sup>
2/0		1.60	1.25	5.43	0.25	0.91	303830	– U26ART U26ART <sup>8</sup>
4/0		1.60	1.25	5.43	0.30	0.91	303759	– U28ART U28ART <sup>8</sup>
250		1.96	1.25	5.88	0.25	1.12	303831	– U249ART U249ART <sup>8</sup>
350		1.91	1.62	6.84	0.38	1.12	303758	– U31ART U31ART <sup>8</sup>
500/600		2.62	1.62	6.78	0.38	1.62	303832	– U34ART U34ART <sup>8</sup>
700/750 <sup>2</sup>		2.65	1.62	8.22	0.62	1.62	303833	– – P39ART
1,000/1,100 <sup>2</sup>		2.97	1.62	8.88	0.62	1.84	303834	– – P44ART
1,250 <sup>3</sup>		2.58	2.60	7.53	0.51	1.84	303835	L727 <sup>6</sup>
1,500 <sup>3</sup>		3.19	3.09	8.59	0.81	2.26	303836	L46ART <sup>6</sup>
1,750 <sup>3</sup>		3.69	3.33	8.38	0.86	2.46	303837	L735 or L735W <sup>6</sup>
2,000 <sup>3</sup>		3.69	3.57	8.50	0.94	2.60	303838	L48ART <sup>6</sup>

*cited in Cal. Rest. Ass'n v. City of Berkeley  
No. 21-16278 am archived December 27, 2023*

### Connectors for Insulated Cables Underground Distribution Systems

**Table 26 Specifications for Terminal Connectors – Aluminum Cable-to-Flat Bar (Figure 15 and Figure 16)  
(Continued)**

Cable Size AWG or kcmil	Refer to	Approved for Purchase						6-Ton Tool Dies # <sup>7</sup> 12-Ton Tool Dies # 15-Ton Tool Dies #
		Approximate Dimensions (inches)					Connector Code	
		B	C <sup>1</sup>	L <sup>1</sup>	T <sup>1</sup>	OD		
6 <sup>5</sup>	Figure 16 4, 5 (stacking terminals)	1.50	0.87	5.25	0.21	0.62	303732	W-BG U-BG U-BG <sup>8</sup>
2 <sup>5</sup>		1.10	0.91	5.62	0.25	0.65	303731	
1/0 <sup>5</sup>		1.10	0.91	5.62	0.25	0.65	303730	
4/0 <sup>5</sup>		1.52	1.17	6.20	0.30	0.91	303729	– U28ART U28ART <sup>8</sup>
250		1.90	1.62	6.6	0.38	1.0	301283	– U249ART U249ART <sup>8</sup>
350 <sup>5</sup>		2.25	1.62	6.84	0.38	1.12	303728	– U31ART U31ART <sup>8</sup>
700/750 <sup>2, 5</sup>		2.65	1.62	8.22	0.62	1.62	303839	– – P39ART
1,000/1,100 <sup>2, 5</sup>		2.97	1.62	8.88	0.62	1.84	303840	– – P44ART

<sup>1</sup> These dimensions may vary slightly among the various suppliers.

<sup>2</sup> These connectors shall be designed to fit side by side on a standard NEMA spade terminal (see Figure 24 on Page 29).

<sup>3</sup> To order 4-hole terminals larger than 1,000 kcmil, select the Burndy or Homac terminal for the proper cable size and substitute 4 for 2 in the catalog number. Example: YA45A-4NTN or Homac AL-750-4NTN. See Figure 17 on Page 22.

<sup>4</sup> If it is necessary to stack copper conductors, use aluminum stacking connectors.

<sup>5</sup> These connectors shall be capable of being stacked on any straight terminal of equal or larger size (up to and including 1,000 kcmil).

<sup>6</sup> These Die require a 60-ton press tool.

<sup>7</sup> Within this column, the first entry corresponds to a 6-ton press tool, the second entry corresponds to a 12-ton press tool, and the third entry corresponds to a 15-ton press tool.

<sup>8</sup> A U-die adapter must be used when utilizing U-dies in a 15-Ton press.



## Connectors for Insulated Cables Underground Distribution Systems

### Terminal Connectors Compression-Type (aluminum cable-to-flat bar for transformer spade terminals)(continued)

Table 27 Terminal Connectors (aluminum cable-to-flat bar)(continued)

Cable Size AWG or kcmil	Approved for Purchase		
	Manufacturer and Catalog Number		Connector Code
	Homac	Burndy	
4	SA4NTN	YAR4U2NTN	303829
2	SA2NTN	YAR2U2NTN	303761
1/0	AL1/0-NTN	YAK25A-2GA	303760
2/0	SA2/0-NTN	YAR2/0U2NTN	303830
4/0	AL4/0-NTN	YA4/0A2NTN	303759
250	SAB4/0-NTN	YA250A2NTN	303831
350	AL350-NTN	YA350A2NTN	303758
500	SAL500-NTN	YA500A2NTN	303832
700/750 <sup>1</sup>	AL750-NTN	YA750A2NTN	303833
1,000 <sup>1</sup>	AL1000-NMS	YA1000A2NTN	303834
1,250 <sup>2</sup>	AL1250-NTN	YA1250A2NTN	303835
1,500 <sup>2</sup>	AL1500-NTN	YA1500A2NTN	303836
1,750 <sup>2</sup>	AL1750-NTN	YA1750A2NTN	303837
2,000 <sup>2</sup>	AL2000-NTN	YA2000A2NTN	303838
Stacking Terminal			
6 <sup>3,4</sup>	ASL 6-NTN	YARSO6U2NTN	303732
2 <sup>3,4</sup>	ASL 386-N	YARSO2U2NTN	303731
1/0 <sup>3,4</sup>	ASL1/0-NTN	YARSO1/0U2NTN	303730
4/0 <sup>3,4</sup>	ASL4/0-NTN	YASO4/0A2NTN	303729
250	ASL250-NTN	YASO250A2NTN	301283
350 <sup>3,4</sup>	ASL350-NTN	YASO350A2NTN	303728
700/750 <sup>1,3,4</sup>	ASL750-NTN	YASO750A2NTN	303839
1,000 <sup>1,3,4</sup>	ASL1000-SSNTN	YASO1000A2NTN	303840

<sup>1</sup> These connectors shall be designed to fit side by side on a standard NEMA spade terminal (see Page 27).

<sup>2</sup> To order 4-hole terminals larger than 1,000 kcmil, select the Burndy or Homac terminal for the proper cable size and substitute 4 for 2 in the catalog number. Example: YA45A-4NTN or Homac AL-750-4NTN.

<sup>3</sup> If it is necessary to stack copper conductors, use aluminum stacking connectors.

<sup>4</sup> These connectors shall be capable of being stacked on any straight terminal of equal or larger size (up to and including 1,000 kcmil).

#### Notes

- The material for these connectors, is tinned aluminum alloy, tubular.
- Attach terminal connectors using Everdur bolts and washers shown on page 28. For ordering Everdur Bolts refer to Table 29 on Page 28.
- Partially filled with oxide inhibitor and sealed. For ordering Everdur bolts refer to Table 30 On Page 28.
- Connections of copper-to-copper, tinned aluminum-to-copper, and tinned aluminum-to-tinned aluminum require no special precautions other than a clean surface. Any combination involving an untinned aluminum surface requires the application of oxide inhibitor to the surface. Wire brush the surface through the compound thoroughly. Brushing through this inhibitor prevents the oxide from reforming. If in doubt as to the materials or tinning, applying inhibitor will do no harm

## Connectors for Insulated Cables Underground Distribution Systems

### Terminal Connectors Compression-Type (copper cable-to-flat bar for transformer spade terminals)

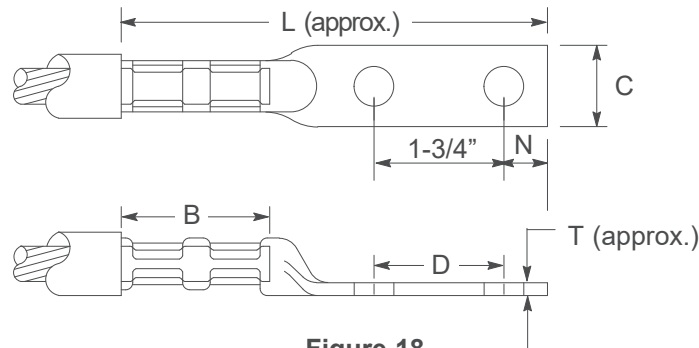


Figure 18

Table 28 Specifications for Terminal Connectors – Copper Cable-to-Flat Bar (Figure 18)

Cable Size AWG or kcmil	Manufacture and Catalog Number		Approved for Purchase							Bolt Size	Connector Code	6-Ton Tool Dies # 1 12-Ton Tool Dies # 15-Ton Tool Dies #
			Dimensions (inches)									
	Homac	Burndy	B	C	D	L	N	T				
4 <sup>5</sup>	L4N	YA4C-2N	1-1/8	13/16	3	4-1/2	5/8	1/8	1/2	303916	W4CRT <sup>2</sup> U4CRT <sup>2</sup> U4CRT <sup>2,6</sup>	
2 <sup>2,5</sup>	L2N	YA2C-2N	1-1/4	13/16	3	4-23/32	5/8	1/8	1/2	303221	W2CRT U2CRT U2CRT <sup>6</sup>	
1 <sup>5</sup>	L1N	YA1C-2N	1-3/8	13/16	3	4-7/8	5/8	1/8	1/2	303804	W1CRT1 U1CRT1 U1CRT1 <sup>6</sup>	
1/0 <sup>5</sup>	L1/0N	YA25-2N	1-3/8	13/16	3	4-29/32	5/8	1/8	1/2	303209	W25RT U25RT U25RT <sup>6</sup>	
2/0 <sup>5</sup>	L2/0N	YA26-2N	1-1/2	13/16	3	4-29/32	5/8	1/8	1/2	303220	W26RT U26RT U26RT <sup>6</sup>	
3/0 <sup>5</sup>	L3/0N	YA27-2N	1-1/2	29/32	3	4-15/16	5/8	1/8	1/2	303219	W27RT U27RT U27RT <sup>6</sup>	
4/0 <sup>5</sup>	L4/0N	YA28-2N	1-5/8	1	3	5-1/16	5/8	9/64	1/2	303917	– U28RT U28RT <sup>6</sup>	
250 <sup>5</sup>	L250-N	YA29-2N	1-5/8	1-3/32	3	5-5/32	5/8	5/32	1/2	303092	– U29RT U29RT <sup>6</sup>	
300	L300-N	YA30-2N	2	1-11/16	3	5-3/4	5/8	5/32	1/2	303451	– U30RT U30RT <sup>6</sup>	
350 <sup>5</sup>	L350-N	YA31-2N	2	1-25/32	3	5-11/16	5/8	3/16	1/2	303452	– U31RT U31RT <sup>6</sup>	
500 <sup>5</sup>	L500-N	YA34-2N	2-1/4	1-17/32	3	5-15/16	5/8	15/64	1/2	303093	– U34RT U34RT <sup>6</sup>	

## Connectors for Insulated Cables Underground Distribution Systems

### **Terminal Connectors Compression-Type (copper cable-to-flat bar for transformer spade terminals)(preferred)**

**Table 28 Specifications for Terminal Connectors – Copper Cable-to-Flat Bar (Figure 18 on Page 25)  
(Continued)**

Cable Size AWG or kcmil	Manufacture and Catalog Number		Approved for Purchase								6-Ton Tool Dies # <sup>1</sup> 12-Ton Tool Dies # 15-Ton Tool Dies #
			Dimensions (inches)						Bolt Size	Connector Code	
			Homac	Burndy	B	C	D	L			
600 <sup>3,4</sup>	L600-N	YA36-2N	2-11/16	1-1/2	3	6-5/8	5/8	17/64	1/2	303454	– U36RT U36RT <sup>6</sup>
750 <sup>3,4,5</sup>	L750-N	YA39-2NN1	2-7/8	1-3/4	3	6-3/4	5/8	17/64	1/2	303296	– P39RT
1,000 <sup>3,5</sup>	L1000N	YA44-2NG10	3	1-3/4	3	6-15/16	5/8	21/64	1/2	303461	P44RT

<sup>1</sup> Within this column, the first entry corresponds to a 6-ton press tool, the second entry corresponds to a 12-ton press tool, and the third entry corresponds to a 15-ton press tool

<sup>2</sup> For #2 Solid, use Burndy 162 die index. For Die ordering information refer to Table 20 on Page 19

<sup>3</sup> Dimension C shall not exceed 1-3/4”.

<sup>4</sup> To order 4-hole terminals, select the Homac or Burndy terminal for the proper cable size and substitute 4 for 2 in the catalog number. For example: YA39-4NNT, for Burndy L750-4N for Homac.

<sup>5</sup> Conductor can be compressed or compact.

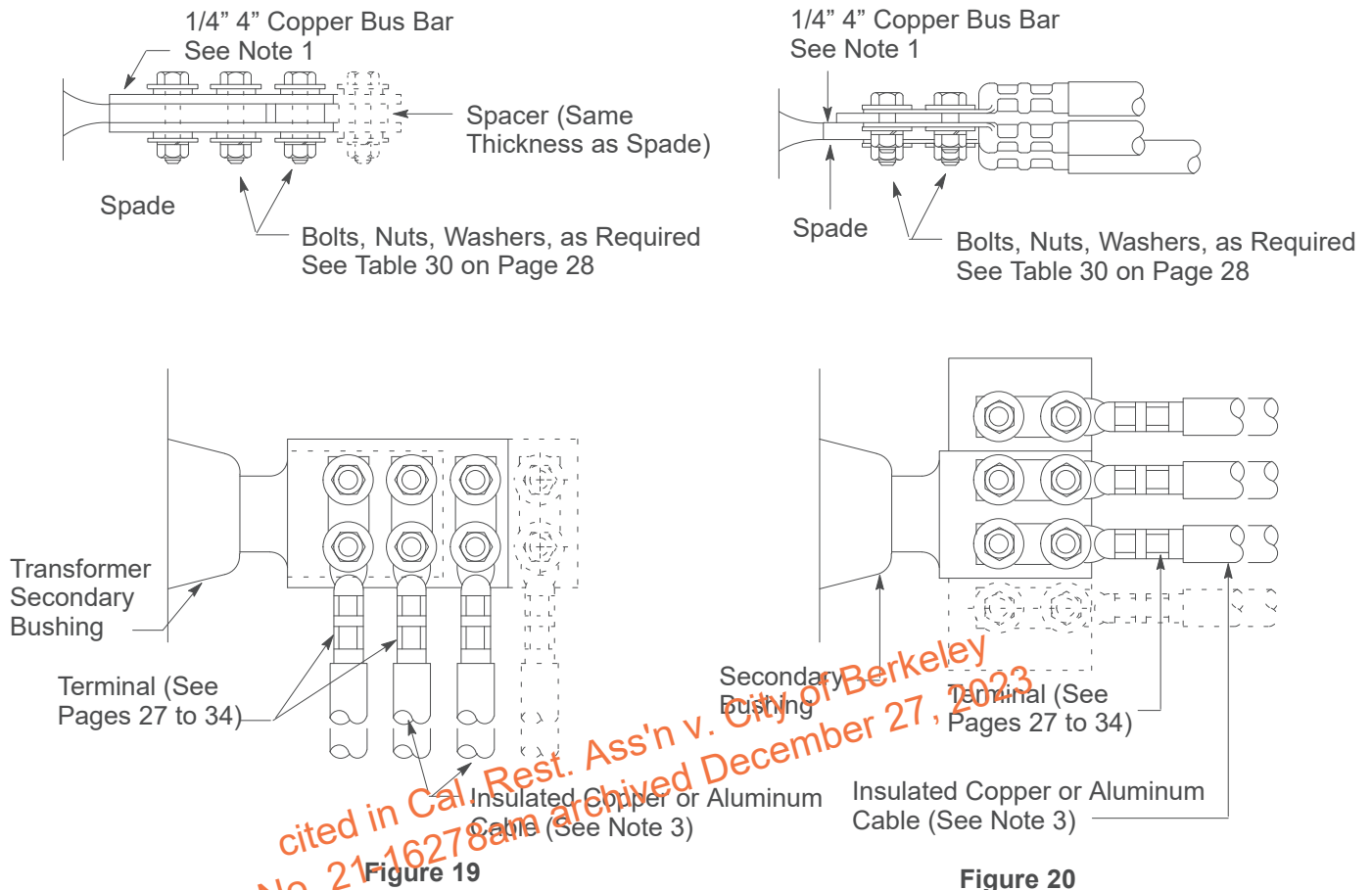
<sup>6</sup> A U-die adapter must be used when utilizing U-dies in a 15-Ton press.

#### Notes

1. Attach using Everdur bolts and washers as shown on Table 30 on Page 28.
2. Connections of copper-to-copper, tinned aluminum-to-copper, and tinned aluminum-to-tinned aluminum pads require no special precautions other than a clean surface. Any combination involving an untinned aluminum surface requires the application of oxide inhibitor to the surface. Wire brush the surface through the compound thoroughly. Brushing through this inhibitor prevents the oxide from reforming. If in doubt as to the materials or tinning, application of the inhibitor will do no harm.

## Connectors for Insulated Cables Underground Distribution Systems

### Applications of Compression-Type Terminal Connectors (preferred)



#### Notes

- Where the transformer spade does not provide sufficient space for cables to be connected, it may be extended with a short length of 1/4" x 4" copper bus bar, 3.86 pounds per foot, **Code M156024**. The current carrying capacity of the bus bar, when insulated with tape is as follows:
  - 1,200 amps for one 1/4" x 4" bus bar.
  - 2,200 amps for two 1/4" x 4" bus bars (one on each side of the spade).
 The spade itself has capacity sufficient for the rating of the transformer.
- Where large size or a large number of cables are attached to secondary spade, they should be supported to prevent excessive strain on the secondary bushings.
- Installations shown in this document **cannot** be used for aluminum cables 1,250 kcmil and larger, or copper cables 750 kcmil and larger, as the flat portion of the connector is wider than the hole spacing provided on the transformer spade.

## Connectors for Insulated Cables Underground Distribution Systems

### Terminal Connectors Bolted-Type (copper cable-to-flat bar for transformer spade terminals)(non-preferred)

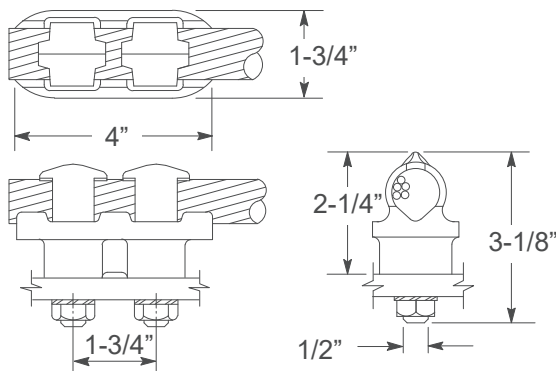


Figure 21

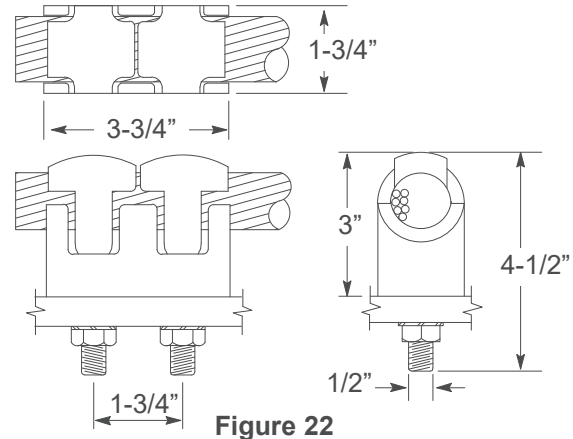


Figure 22

**Table 29 Connectors (copper cable eye bolt-to-flat bar type) <sup>1</sup>**

Use for Cable Range (AWG-kcmil)	Manufacturer and Catalog Number						Code
	Refer to	A.E. Corp. <sup>2</sup>	Bumdy	So. States	Royal	Dossert	
2/0-500	Figure 21	TLD-62	QQGF34-G6	UNNS-4656T	12222	T2L-50E	303169
600-1,000	Figure 22	TLDN-86	QQGFL44-G4	UNNS-5666T	19500	T2L-50E	303286

<sup>1</sup> Connectors shown in Figure 21 and Figure 22 have two cable clamping elements and require a minimum of space and taping. The recommended tightening force for the 1/2" eye bolt on these connectors is 25-40 foot-pounds.

<sup>2</sup> Formerly Anderson Brass Works.

#### Note

1. See Pages 24 to 29 for preferred compression connectors for this application.

**Table 30 Bolts, Nuts, and Washers (Figure 21 above, Figure 26 on Page 30, Figure 36 on Page 37) <sup>1, 2, 3</sup>**

Item	Description	Code
1	Screw, Cap (bolt) Everdur, Hex. Head 1/2" x 1-1/2" <sup>1, 2</sup>	193023
2	Screw, Cap (bolt) Everdur, Hex. Head 1/2" x 2" <sup>1, 2</sup>	193025
3	Screw, Cap (bolt) Everdur, Hex. Head 1/2" x 2-1/2" <sup>1, 2</sup>	193177
4	Nut, Bolt, Everdur, Hex. 1/2" <sup>1</sup>	195013
5	Washer, Round, Everdur, 1/2"	195252
6	Washer, Lock, Everdur, 1/2"	195193
7	Screw, Cap (bolt), Steel, CDPL, Hex. HD 1/2" x 1-1/2"	193271
8	Screw, Cap (bolt), Steel, CDPL, Hex. HD. 1/2" x 2"	193272
9	Screw, Cap (bolt), Steel, CDPL, Hex. HD. 1/2" x 2-1/2"	193273
10	Screw, Cap (bolt), Steel, CDPL, Hex. HD. 1/2" x 3"	193274
11	Nut, Bolt, Steel, CDPL, Hex. 1/2"	195449
12	Washer, Round, Steel, CDPL 1/2"	195450
13	Washer, Lock, Steel, CDPL 1/2"	195451

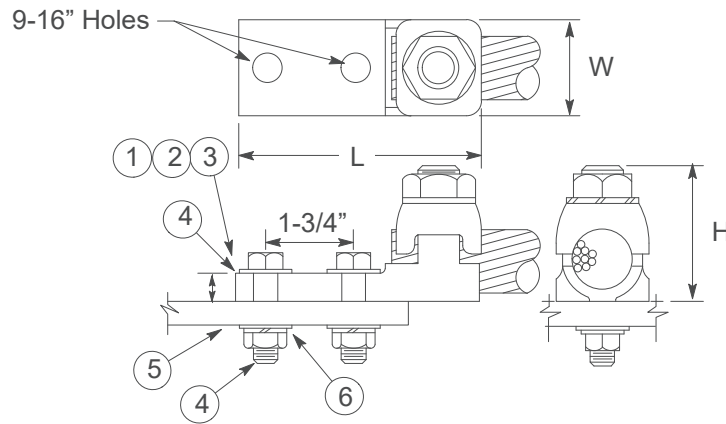
<sup>1</sup> The recommended tightening force for a 1/2" Everdur bolt is 40 foot-pounds. Normally, the use of an 8" wrench will give this range of torque.

<sup>2</sup> Everdur cap screws are low silicon bronze, Spec 651 per ASTM F468 with Class 2A threaded.

<sup>3</sup> Use Items 1 - 6 as shown in Figure 23 on Page 29 and Figure 36 on Page 37. Use Items 7 - 13 as shown in Figure 26 on Page 30.

**Connectors for Insulated Cables  
Underground Distribution Systems**

**Terminal Connectors Bolted-Type  
(copper cable-to-flat bar for transformer spade terminals)(non-preferred) (continued)**



**Figure 23**

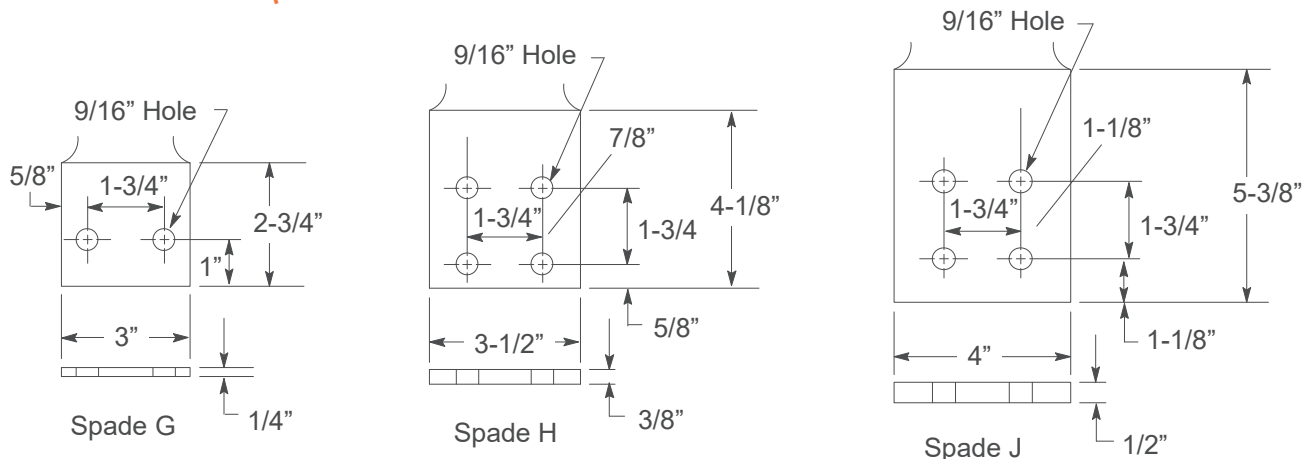
**Table 31 Connectors – Bolted Tongue-to-Copper Cable Type <sup>1</sup> (Figure 23)**

Use for Cable Range (kcmil)	Manufacturer and Catalog Number			Dimensions (inches) <sup>2</sup>				Connector Code
	Burdny	Royal	Dossert	L	W	H	T	
400-500	QA34-2N	18726	HL 50-2N	4-11/16	1-3/8	1-15/16	5/16	303188
600-800	QA40-2N	18727	HL 80-2N	4-13/16	1-5/8	2-5/16	3/8	303298
850-1,000	QA44-2N	18728	HL 100-2N	4-15/16	1-7/8	2-1/2	1/2	303189

<sup>1</sup> Bolt on these connectors is 40 foot-pounds of applied torque.  
<sup>2</sup> Dimensions shown are for Burdny connectors; others may vary slightly.

**Notes**

- Figure 24 Below shows standard transformer spade terminals per Electronic Edison Institute (EEI) Specification.



**Figure 24  
Standard Transformer Spade Terminals (EEI-NEMA)**

## Connectors for Insulated Cables Underground Distribution Systems

### Terminal Connectors Bolted-Type (copper cable-to-flat bar for transformer spade terminals)(non-preferred)(continued)

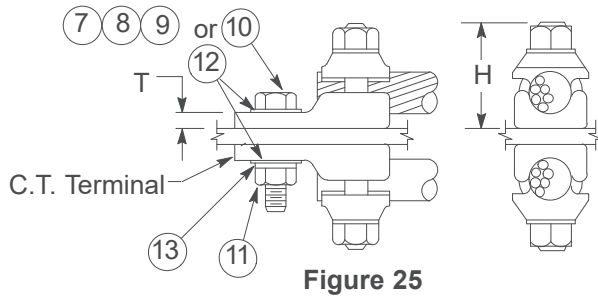
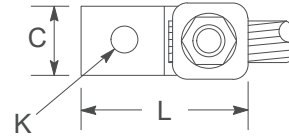
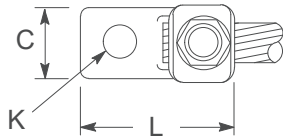


Figure 25

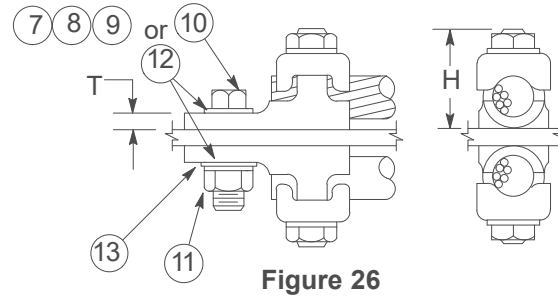


Figure 26

**Table 32 Connectors – Copper Cable Eyebolt-to-Flat Bar Type (Figure 25 and Figure 26)**

Cable Range (AWG or kcmil) Min – Max	Manufacturer and Catalog Number			Approximate Dimensions (inches) <sup>1</sup>				Code
	Figure 26	Figure 26	Figure 25	H	L	W	K	
	Burndy	Royal	Dossert					
2 – 350	QGFL-31B1	12208	QL35	2-3/4	1/2	2-3/4	1-7/16	303165
1/0 – 500	QGFL-34B1	12209	QL50	3-3/16	1/2	2-1/4	1-13/16	303233
750 – 1,000	QGFL-44B1	12212	QL100	5-1/2	1/2	2-1/4	2-3/16	303179

<sup>1</sup> The recommended tightening force for the 1/2" eye bolt on these connectors is 40 foot-pounds of applied torque.

<sup>2</sup> Dimensions shown are for Burndy connectors; others may vary slightly.

### Terminal Connectors Bolted-Type (copper cable-to-flat bar for current transformer terminals only)

**Table 33 Connectors – Cable-to-Flat Bar-to-Copper Cable Type (Figure 25 and Figure 26)**

Cable Range (AWG or kcmil) Min – Max	Manufacturer and Catalog Number				Approximate Dimensions (inches) <sup>1</sup>					Code
	Figure 25	Figure 26	Figure 25	Figure 26	C	H	K (min.)	L	W	
	A.E. Corp.	Burndy	Royal	Dossert						
3/0 – 4/0	ITE024-A	QA28-B3	18723	HL 21-1-50	1	1-7/16	9/16	2-1/4	1/4	303297
250 – 350	ITE035-A	QA31-B	18724	HL 35-1	1-3/16	1-11/16	17/32	2-11/16	5/16	303182
400 – 500	ITE050-A	QA34-B	18725	HL 50-1	1-3/8	2	17/32	3-3/16	5/16	303112
600 – 800	ITE080-A	QA40-B	19600	HL 75-1	1-5/8	2-3/8	11/16	3-11/16	3/8	303122
850 – 1,000	ITE100-A	QA44-B	19601	HL 100-1	1-7/8	2-1/2	11/16	3-15/16	1/2	303121

<sup>1</sup> Dimensions shown are for Burndy connectors; others may vary slightly.

#### Notes

- Connectors shown in Table 32 on Page 30 are less costly than those shown in Table 33 and should be used when connecting one cable to bar-type primary terminal.
- Use connectors shown in Table 32 on Page 30 to connect two cables to bar-type primary terminal by placing them back-to-back as shown in Figure 25 and Figure 26.

Where severe corrosive conditions exist, use Everdur cap screws, nuts, and washers shown in Table 30 on Page 28.

## Connectors for Insulated Cables Underground Distribution Systems

### Tap Connectors for Cable Termination (copper or aluminum cable) Pad-Mounted Transformers

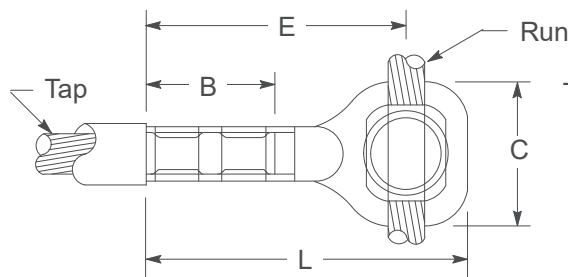


Figure 27

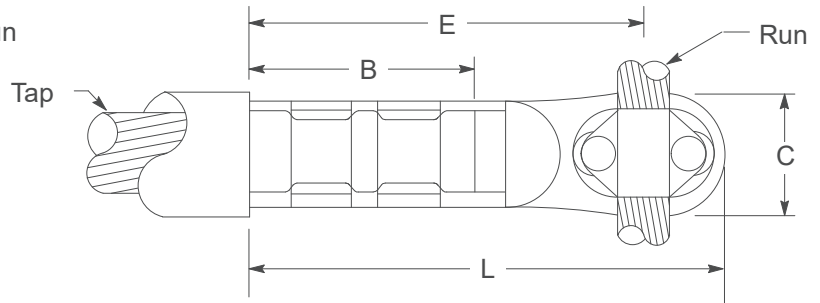
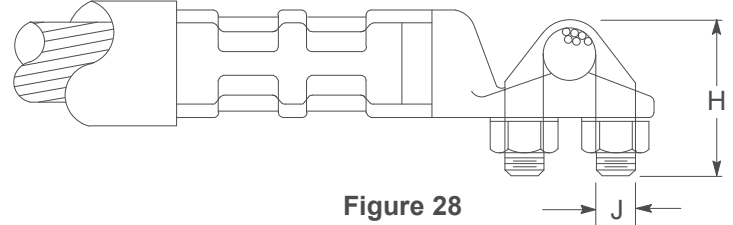
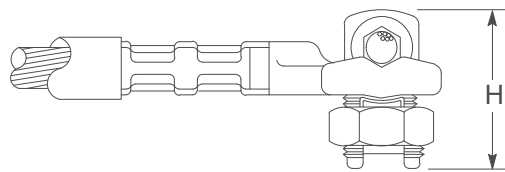


Figure 28



**Table 34 Tap Connectors – Tee-Type (copper-to-copper, for circuits 5,000 V or lower)**

Cable Size AWG or kcmil		Approved for Purchase							6-Ton Tool Dies # <sup>1</sup> 12-Ton Tool Dies # 15-Ton Tool Dies #			
Run	Tap	Refer to	Dimensions (inches)					Bundy Catalog Number	Dossier Catalog Number	Code		
			B	C	E	H	L					
6 to 2/0	2	Figure 27	1-11/32	1-5/8	2-17/32	1-13/16	-	3-7/32	VYT262CG 1	UTDK 13-6	305638	W2CRT U2CRT U2CRT <sup>2</sup>
6 to 2/0	2/0		1-17/32	1-5/8	2-23/32	1-13/16	-	3-13/32	VYT2626G 1	UTDK 13-13	305639	W26RT U26RT U26RT <sup>2</sup>
1/0 to 300	2	Figure 28	1-11/32	1-3/8	2-3/4	1-27/32	7/16	3-23/32	VYT302C	UTSK 30-6	305640	W2CRT U2CRT U2CRT <sup>2</sup>
1/0 to 300	2/0		1-17/32	1-3/8	3-1/16	1-27/32	7/16	4	VYT3026	UTSK 30-13	305641	W26RT U26RT U26RT <sup>2</sup>
1/0 to 300	250		1-21/32	1-3/8	3-1/4	1-27/32	7/16	4-7/32	VYT3029	UTSK 30-25	305642	- U29RT U29RT <sup>2</sup>
1/0 to 300	500		2-9/32	1-3/8	3-1/16	1-27/32	7/16	5	VYT3034	UTSK 30-50	305643	- U34RT U34RT <sup>2</sup>

<sup>1</sup> Within this column, the first entry corresponds to a 6-ton press tool, the second entry corresponds to a 12-ton press tool, and the third entry corresponds to a 15-ton press tool.

<sup>2</sup> A U-die adapter must be used when utilizing U-dies in a 15-Ton press.

#### Notes

- If Tee Connectors, shown in Figure 27 and Figure 28 are to be attached to an aluminum overhead conductor run, use a short length of bare copper conductor between the connector and the aluminum conductor, and attach it with a fired wedge per [Document 066194](#).
- If the desired connector size is not shown, special sizes may be acquired by ordering a connector similar to the connector shown.



Connectors for Insulated Cables  
Underground Distribution Systems

Tap Connectors for Cable Termination (copper or aluminum cable) Pad-Mounted Transformers (continued)

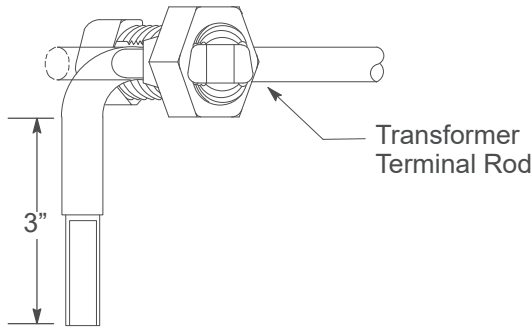


Figure 29

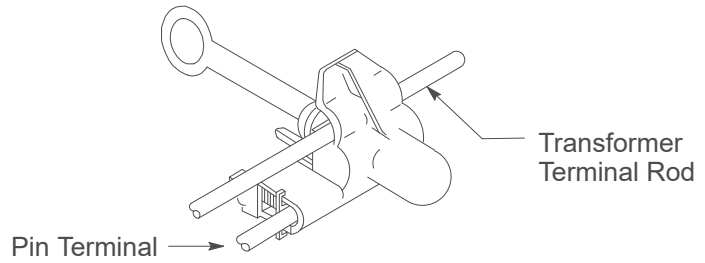


Figure 30  
Blackburn Catalog Number PGH3, Code 305997

Application: Tap clamp for live-front loop-style, 3-phase pad-mounted transformer. [Document 045291](#) and [Document 057521](#) conductor range #2 AWG to 2/0.

Application

See "Low Profile" Single-Phase 6.9 and 12 kV pad-mounted transformer, [Document 042762](#) and [Document 042765](#).

Table 35 Tap Connectors for Cable Termination in "Low-Profile" Pad-Mounted Transformers (Figure 29)

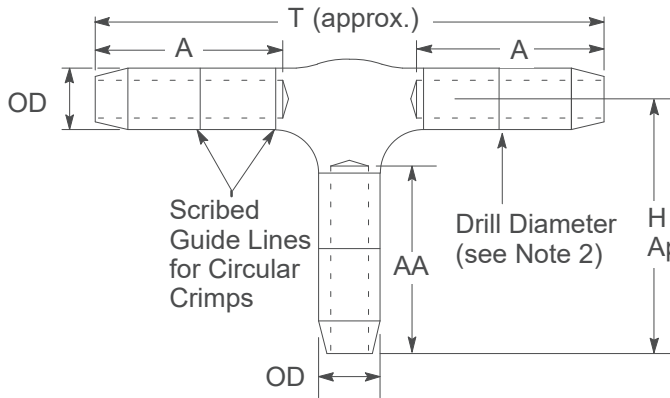
Connector Size AWG or kcmil	Manufacturer and Catalog Number		6-Ton Tool Dies # <sup>1</sup> 12-Ton Tool Dies # 15-Ton Tool Dies #	Connector Code
	Kortick	PMT		
4 Cu		PMT-201	W4CRT UCRT UCRT <sup>2</sup>	305057
2 Cu		PMT-201	W2CRT U2CRT U2CRT <sup>2</sup>	305058
2 Al		PMTA-201	W2CART U2CART U2CART <sup>2</sup>	305153
1/0 Al		PMTA-1001	- U25ART U25ART <sup>2</sup>	305264

<sup>1</sup> Within this column, the first entry corresponds to a 6-ton press tool, the second entry corresponds to a 12-ton press tool, and the third entry corresponds to a 15-ton press tool.

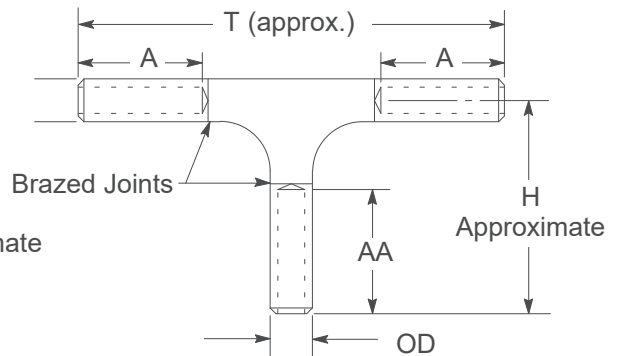
<sup>2</sup> A U-die adapter must be used when utilizing u-dies in a 15-ton press.

**Connectors for Insulated Cables  
Underground Distribution Systems**

**Primary T-Connectors, Compression-Type, 5 kV or Above  
Aluminum-to-Aluminum, Copper-to-Aluminum, or Copper-to-Copper**



**Figure 31**



**Figure 32**

**Table 36 Primary T-Connectors, Compression-Type - Aluminum-to-Aluminum or Copper-to-Aluminum (refer to Figure 31)**

Conductor Size AWG or kcmil		Approved for Purchase					6-Ton Tool Die # 12-Ton Tool Die # 15-Ton Tool Die #
		Dimension (inches)		Manufacturer and Catalog Number		Conductor Code	
Run	Tap	A		Burndy	DeSmet		See Table 38 on Page 35
2	2	1-21/32	1-7/8	YST2CU2CUT	CVT6-6-S-AA	305266	
4	2	1-21/32	1-7/8	YST4CU2CUT	CVT4-6-S-AA	305268	
1/0	1/0	1-3/4	1-7/8	YST25U25UT	CVT10-10-S-AA	305270	
1/0	2	1-3/4	1-7/8	YST25U2CUT	CVT10-6-S-AA	305271	
#2-4/0	#2-4/0	3-3/32	-	YST28TG1	CVT6-6-S-AA	305380	
4/0-250	#2-250	3-5/8	-	YST29TG1	CVT21-6-S-AA	305384	
350-500	#2-500	4-9/32	-	YST34TG1	CVT35-6-S-AA	305386	
700-1,000 <sup>1</sup>	#2-700 <sup>1</sup>	4-25/32	-	YST39TG1	CVT70-6-S-AA	305398	

<sup>1</sup> Maximum conductor size for aluminum only. Maximum copper size is 750 kcmil for run and 500 kcmil for tap.

## Connectors for Insulated Cables Underground Distribution Systems

### **Primary T-Connectors, Compression-Type, 5kV and Above Aluminum-to-Aluminum, Copper-to-Aluminum, or Copper-to-Copper (continued)**

**Table 37 Primary T-Connectors, Compression-Type - Copper-to-Copper (refer to Table 32 on Page 30)**

Conductor Size AWG or kcmil		Dimensions (inches)						Manufacturer and Catalog Number			Connector code	6-Ton Tool Die # 12-Ton Tool Die # 15-Ton Tool Die #
		A	AA	H	T	OD		Burdby	Homac	Dossert		
Run	Tap					Run	Tap					
2	2	1.23	1.23	2.16	4.31	0.42	0.42	YSTP2C2CT	2T2	CVT6-6	305808	W2CRT U2CRT U2CRT <sup>2</sup>
2	4	1.23	1.09	2.04	4.31	0.42	0.34	YSTP2C4CT	2T4	CVT6-4	305809	
4	4	1.09	1.09	1.84	3.88	0.34	0.34	YSTP4C4CT	4T4	CVT4-4	305810	

<sup>1</sup> Within this column, the first entry corresponds to a 6-ton press tool, the second entry corresponds to a 12-ton press tool, and the third entry corresponds to a 15-ton press tool.

<sup>2</sup> A U-die adapter must be used when utilizing u-dies in a 15-ton press.

#### Notes

1. The material of these connectors is aluminum or copper with a tinplated finish.
2. Barrels are factory drilled to accommodate the minimum conductor OD.
3. Connectors shall be filled with oxide inhibitor and sealed

#### Application

Tap splices for above 5,000 V, see [Document 041583](#) and [Document 043901](#)

cited in Cal. Rest. Ass'n v. City of Berkeley  
No. 21-16278am archived December 27, 2023

**Connectors for Insulated Cables  
Underground Distribution Systems**

**Primary T-Connectors, Compression-Type,  
Aluminum-to-Aluminum, Copper-to-Aluminum or Copper-to-Copper (continued)**

Table 38 Tooling from Table 36 on Page 33

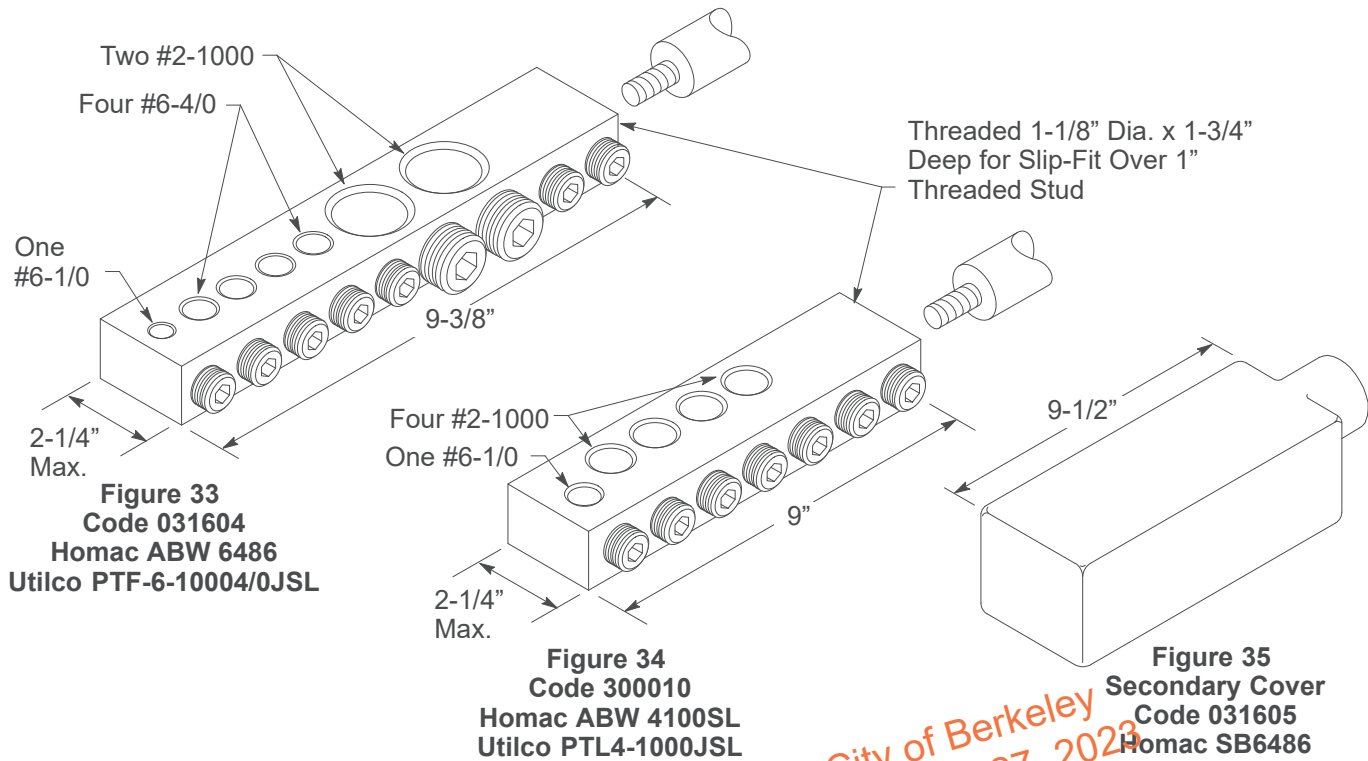
Connector Code	6-Ton Tool Dies # <sup>1</sup> 12-Ton Tool Dies # 15-Ton Tool Dies #	
	Run	Tap
305266	- U25ART U25ART	- U25ART U25ART <sup>2</sup>
305268	W2CART U2CART U2CART	
305270	W27ART U27ART U27ART	W27ART U27ART U27ART <sup>2</sup>
305271		- U25ART U25ART <sup>2</sup>
305380	- U31ART U31ART	- U31ART U31ART <sup>2</sup>
305384	- U39RT P39ART	- U39ART U39ART <sup>2</sup>
305386	U39ART P39ART	
305398	- - P44ART	- U39ART P39ART

<sup>1</sup> Within this column, the first entry corresponds to a 6-ton press tool, the second entry corresponds to a 12-ton press tool, and the third entry corresponds to a 15-ton press tool.

<sup>2</sup> A U-die adapter must be used when utilizing u-dies in a 15-ton press.

### Connectors for Insulated Cables Underground Distribution Systems

#### Slip-Fit Connector Installation, Aluminum or Copper Cable



#### Scope

This page shows slip-fit connectors for single-phase, dead-front transformer, low voltage, secondary installations (see [Document 064308](#)).

#### Notes

1. All set screws to be 5/16" Allen head drive.
2. The bar is rated in excess of 1,600 amps, which exceeds the maximum allowable transformer load.
3. Connectors may be used for aluminum or copper conductors.
4. Never combine conductors in one port.
5. Connector is designed to slip onto the stud even though the terminal is threaded.
6. Secondary cover, see Figure 35, is a tool to be used when required to insulate the energized secondary slip-fit connectors.

#### Instructions

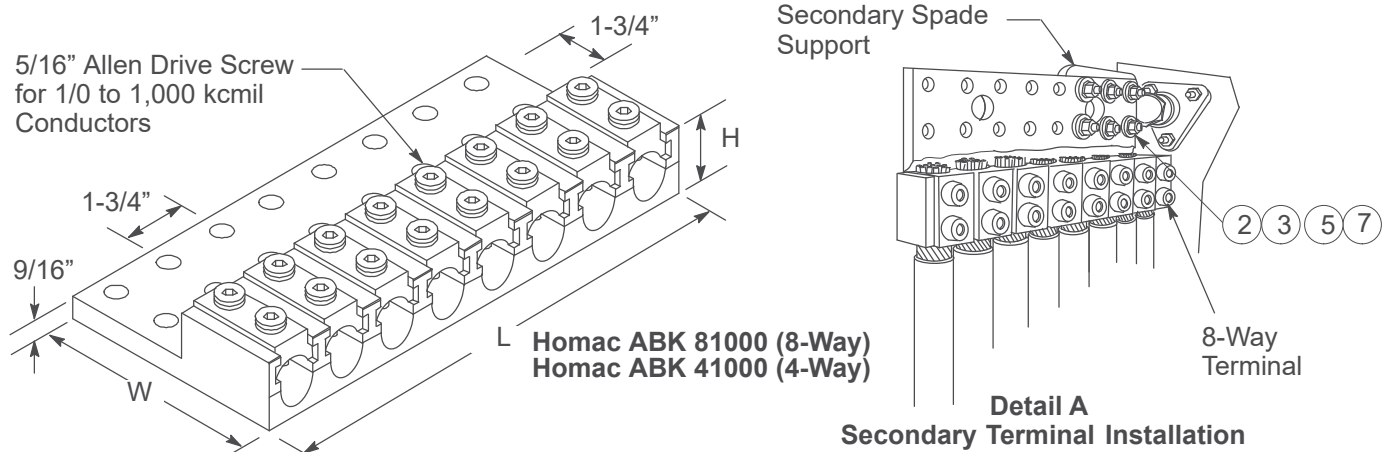
1. Remove any jam nuts from transformer studs.
2. Slide the connector onto the transformer stud, position the connector to allow a straight, smooth cable entry, mesh the threads together, and tighten the setscrews to lock the connector in place.
3. To prepare the cable, remove the insulation, wire brush the conductor, and apply inhibitor.
4. Insert the conductor in the port and tighten the setscrew.
5. After completing work on the secondary connectors, make sure all connections are tightened as indicated in Table 39.

**Table 39 Conductor/Torque**

Conductor	Torque (ft/lbs)
#6 – 350 and Transformer Stud	25
500 – 1,000	40

## Connectors for Insulated Cables Underground Distribution Systems

### Multiple Transformer Terminal Aluminum or Copper Cable



**Figure 36**  
8-Way Terminal Illustrated (1,000 kcmil)

**Table 40 EZ Keeper Lay-In Terminals for Copper or Aluminum Conductors (600 V or lower)**  
(refer to Figure 36)

Conductor Range	Ampacity (minimum)	Number of Conductors	Dimensions – Approximate (inches)			Mounting Hole Diameter	Code
			L	W	H		
1/0 – 1,000	3100	4	7.0	6.25	1-7/8	9/16"	301281
	5100	8	13.75	6.25			301282

#### Scope

These connectors are for use in connecting service cables from 1/0 to 1,000 kcmil to the spade of three-phase, pad-mounted transformers ([Document 043817](#) and [Document 045291](#)). Cable-to-flat bars are replaced in this design by set screws and a removable lay-in connection. If needed to terminate a #2 neutral onto one of these bars, it is necessary to splice a piece of 1/0 tail for insertion into the lay-in port.

#### Notes

1. Connectors may be used for copper or aluminum conductors.
2. Never put more than one cable in a port.
3. Install the lower ( $X_0$  and  $X_2$ ) connectors first, then the higher ( $X_1$  and  $X_3$ ). Use as many bolts as there are holes in the spade.
4. If transformer spades are not supported, install a secondary cable support kit (see [Document 045291](#)).
5. To prepare the cable, remove the insulation, wire brush the conductor, and apply inhibitor.
6. Make sure all set screws are tightened as indicated in Table 39 on Page 36. (Torque them to the specified value, wait 5 minutes, and make the final torque).
7. See Table 30 on Page 28 for bolts, nuts, and washers.

## Connectors for Insulated Cables Underground Distribution Systems

### Pin Terminals

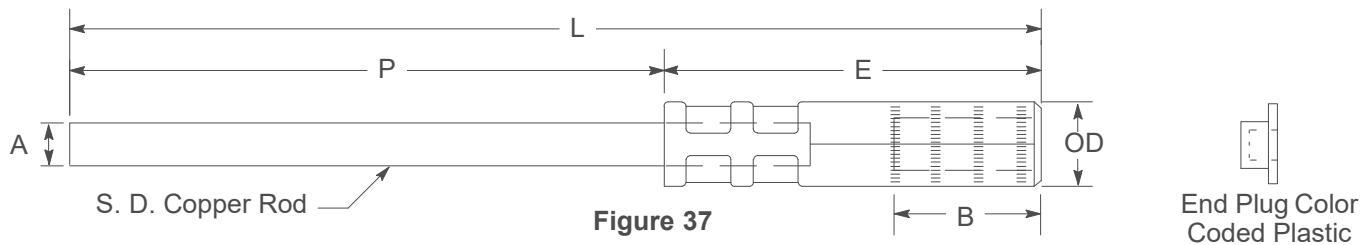


Figure 37

Table 41 Specifications for Aluminum Pin Terminal <sup>1</sup>

Copper/ Al. Cable Size	Copper Stud Equivalent	Approved for Purchase									6-Ton Tool Die # <sup>1</sup> 12-Ton Tool Die # 15-Ton Tool Die #
		Manufacturer and Catalog Number		Dimension (inches)						Code	
		Homac	Brundy	A	B	OD	E Approx.	L Approx.	P		
6	8	SAPT-6-26	YE6R-40	0.250	1.75	0.65	3.25	9.25	6.00	303843	W-BG U-BG U-BG <sup>2</sup>
2	4	SAPT-2-26	TE2R-40	0.250	1.75	0.65	3.25	9.25	6.00	303844	
1/0	2	SAPT-1/0-26	YE25R-60	0.250	1.75	0.65	3.25	9.25	6.00	303845	
4/0	2/0	SAPT-4/0-206	YE28R-60	0.375	1.54	0.91	3.50	10.9	6.00	303846	W249 U249 U249 <sup>2</sup>
350	4/0	PTB-350-6	YE31AG3	0.460	2.25	1.12	4.70	10.7	6.00	303554	- U31ART U31ART <sup>2</sup>
500/600	500	PTM-500-346	YE34AP-GE	0.750	2.56	1.57	6.30	12.3	6.00	300013	- U34ART <sup>3</sup> U34ART <sup>2,3</sup>
700	500	PTL-750	YE39AGB	0.750	2.56	1.60	6.30	12.3	6.00	303555	- - P39ART
1,000	700	PTF-1000-346	YE44AG7	0.750	2.56	1.60	6.30	12.3	6.00	033757	- - P44ART

<sup>1</sup> Within this column, the first entry corresponds to a 6-ton press tool, the second entry corresponds to a 12-ton press tool, and the third entry corresponds to a 15-ton press tool.

<sup>2</sup> A U-die adapter must be used when utilizing U-dies in 15-ton press tool.

<sup>3</sup> Homac equivalent of this die is 106A.

### Notes

- The material for the pin terminals is on Table 41. Copper Rod-Soft Drawn, Tinned, Aluminum Connector EC Grade, Untinned
- Connector is supplied pre-filled with inhibitor and sealed.
- Connector is supplied pre-filled with inhibitor and sealed.
- Pin terminals connected to copper secondary conductors use a copper connector. Pin terminals connected to aluminum secondary conductors use a fired wedge or h-tap.

### Application

- To make straight connections of insulated aluminum secondary neutral to bare copper neutral, see Note 10 Page 7.
- To connect aluminum primary stress cone termination to terminal tap connector or cutout.
- To make watertight termination for secondary risers.

## Connectors for Insulated Cables Underground Distribution Systems

### Pin Terminals (continued)

**Table 42 Color Coding**

Color Coding Requirements for Plastic End Plugs in Pin Terminals	
Conductor Size	Plug Color
#6	Blue
#2	Red
1/0	Yellow
4/0	Pink
350	Brown
700	Purple

**Table 43 Specifications and Ordering Information for Copper Pin Terminal**

Cu Cable Size	Cu Stud Size	Manufacturer and Catalog Number			Dimensions (inches)						6-Ton Tool Die # <sup>1</sup> 12-Ton Tool Die # 15-Ton Tool Die #	Code
		Dossert	Mac Prod Co.	Brundy	A	B	OD	E	L	P		
2	2	SDP 6-PG	CAS2-2	YE2CLH128	0.25	1.25	0.415	2.25	9.00	6.00	W2CRT U2CRT U2CRT <sup>2</sup>	303847

<sup>1</sup> Within this column, the first entry corresponds to a 6-ton press tool, the second entry corresponds to a 15-ton press tool.

<sup>2</sup> A U-die must be used when utilizing u-dies 15-ton press tool.

#### Notes

- The material for the pin terminals on Table 43 is copper rod, soft drawn, tinned.
- Rod may be bent for installation convenience. It is recommended that bending take place 1/2" beyond the copper sleeve.

#### Application

- To make straight connections of insulated aluminum secondary neutral to bare copper neutral, see Note 10 Page 7.
- To connect bare copper secondary neutral to aluminum bar connector using Thermofit boot, see [Document 036640](#).
- To make watertight termination for secondary risers.

#### Revision Notes

Revision 07 has the following changes:

- Updated manufacturers information in Table 14 on Page 14.
- Revised left image of Figure 9 on Page 14.
- Corrected typo on Material code on Table 22 on Page 20.
- Revised Die number for several Aluminum connectors in Table 26 starting on Page 22.
- Revised Die number for several Copper connectors in Table 28 starting on Page 25.



cited in Cal. Rest. Ass'n v. City of Berkeley  
No. 21-16278am archived December 27, 2023



**REQUIREMENTS FOR CUSTOMER-OWNED POLES**

**025055**

**Asset Type:** Electric Distribution      **Function:** Construction  
**Issued by:** Daniel Jantz (DWJ7) *D. Jantz*      **Date:** 3/25/2022

**Rev. #20:** This document replaces PG&E Document 025055, Rev. #19. For a description of the changes, see Page 17.

**This document is also included in the following manuals:**

- [Electric and Gas Service Requirements Manual](#) (Greenbook)
- [Electric Meter Work Practices](#)

**Purpose and Scope**

Equipment installed on service poles as shown in this document will also meet the requirements of the California Building Standards Code - Electrical Regulations. These requirements have been established by the state of California in the interest of safety to the public and to workers and are applicable to all customer-owned service poles. PG&E cannot establish service to poles that do not meet these minimum requirements. The maintenance of customer-owned service poles in conformity with these requirements is the sole responsibility of the customer.

Local ordinances may include wiring requirements in addition to those shown in this document. Consult local inspection authorities for these requirements and for city or county permits and inspections that may be required before service can be connected.

**References**

	Location	Document
<a href="#">Methods of Attaching Services to Customers Premises</a>	OH: Services	<a href="#">025202</a>
<a href="#">Dead-End and Angle Attachments for Aluminum Conductors - Distribution Lines</a>	OH: Conductors	<a href="#">028851</a>
<a href="#">Connectors for Aluminum Conductors on Distribution Lines</a>	OH: Conductors	<a href="#">028852</a>
<a href="#">Temporary Underground Electric Service Single-Phase, 120/240 Volt 200 Amps Maximum</a>	UG-1: Services/Greenbook	<a href="#">036670</a>
<a href="#">Conductors for Overhead Lines</a>	OH: Conductors	<a href="#">059626</a>
<a href="#">Overhead and Underground Panel Board Construction</a>	OH Services/UG-1 Services/Greenbook	<a href="#">065374</a>
<a href="#">Utility Standard TD-2325S, "Wood Pole Inspection, Testing, and Maintenance"</a>	TIL	<a href="#">TD-2325S</a>

*Waterbury v. City of Berkeley, 2023 Cal. App. 1 (2023) cited in Cal. Rest. Ass'n v. City of Berkeley, No. 21-16278am archived December 27, 2023*

**Temporary Service Pole Installation**

1. The use of temporary service poles must be restricted to installations of a temporary nature, such as building construction, temporary sales locations, etc., where the period of service is estimated to be 1 year or less.
2. Temporary service poles must be furnished and installed by the customer and may be wooden or metallic. The minimum length must be 20 feet (set 4 feet in the ground). A longer pole may be necessary to provide the required clearance from the ground (see Note 9 on Page 4) or to supply the customer's overhead line (see Figure 3 on Page 8).
3. A temporary, wood service pole may be rectangular or circular in cross section and must be solid (not laminated). Rectangular poles must have a minimum cross section of 6" x 6" nominal; circular poles must meet the requirements for permanent service poles specified in Note 7 on Page 2 except that the minimum length may be 20 feet providing the required clearances are maintained.
4. The butt of the temporary, wood service pole must at least be painted with creosote or other approved preservative. However, it is recommended that these poles be full-length treated with a suitable preservative in order to obtain the maximum useful life of the pole and to provide increased safety to workers and to the

## Requirements for Customer-Owned Poles

public. The permanent service pole specified in Note 6 below is approved for temporary installations. It will usually be the more economical pole for repeated use.

5. A metal pole may be used for temporary service provided its strength is at least equivalent to the wood service poles specified in Note 3 on Page 1 and provided its base or foundation is designed to provide at least an equivalent resistance to overturning when set at the same depth. The use of 4-inch extra-strong steel pipe (Schedule 80), set in concrete to obtain equivalent bearing surface, or the use of a 5-inch standard steel pipe (Schedule 40), set directly in the ground, will meet these requirements.

**Permanent Pole Installation**

6. A permanent wood or metal service pole must be used when it is estimated that the installation will remain for a period longer than 1 year. Permanent wood service poles, as specified in Note 7, must be furnished and installed by the customer. PG&E will, however, furnish and install the pole (wood or metal) exclusive of wiring and service entrance equipment, at the customer's expense, if the customer is unable to have the pole installed by a private contractor.
7. Customer Owned Wood Poles:
  - A. Customer-owned, permanent wood poles must meet all pertinent requirements of ANSI O5.1.2008, "Wood Poles – Specifications and Dimensions," and American Wood Protection Association Standards T1-10 and U1-10, as modified or described in [Engineering Material Specification 57, "Preservative Treated Wood Poles and Stubs for Overhead Lines."](#)
  - B. Approved pole suppliers and treatments are shown in Table 1 and Table 2 of this document.
  - C. For poles that will have a final height greater than 20 feet above ground level, the Federal Aviation Administration (FAA) may require the applicant to file a notice a minimum of 45 days prior to the installation of the pole. The FAA may issue a determination of hazard to air navigation and recommend actions to mitigate or eliminate that hazard. Please contact your PG&E project coordinator for additional information.
  - D. When planning to install a new customer owned service pole prior to inspection by PG&E personnel see the section, Verifying Depth of Customer Owned Poles, on Page 6 and Figure 12 "Pole Depth Verification", on page 17.

After setting the pole(s), the customer contractor must notify the local PG&E inspector who will look at the pole(s) to verify that they meet the requirements stated within this note (Note 7).

- E. Customer-owned, permanent wood poles must be of circular cross section, minimum Class 6, with a minimum length of 25 feet (See Setting Depths in Table 3 on Page 3). A longer pole may be necessary to obtain the required clearance from the ground. Consult PG&E before ordering. Exception: minimum length may be 20 feet providing the required clearances are maintained.
- F. The pole brand must remain visible at all times. The customer-owner shall not install the main service switch meter socket box, or conduit runs over the brand.
- G. Used poles may be installed provided they are inspected and accepted by PG&E **before** installation.
- H. Applicants must obtain a certificate of treatment or a letter from a supplier indicating that the pole was treated in accordance with the American Wood Protection Association (AWPA) and ANSI requirements. PG&E should receive a copy of this certificate before accepting the pole.
  - I. **Do not** notch, cut, chip, or damage the pole in any way. As this affects the integrity of the pole.
8. A metal pole may be used for permanent service provided its size and strength are at least equivalent to the wood pole described in Note 7, and provided its base or foundation is designed to provide at least equivalent resistance to overturning when set at the same depth. The following are some poles that will meet these requirements:
  - A. An 11-gauge steel pole with 8-1/2-inch minimum diameter at ground line, set directly in the ground.
  - B. A 7-gauge steel pole with 7-inch minimum diameter at ground line, set directly in the ground.
  - C. A 5-inch extra-strong steel pipe (Schedule 80) set in concrete to obtain equivalent bearing surface.
  - D. A 6-inch standard steel pipe (Schedule 40) set in concrete to obtain equivalent bearing surface.

All steel permanent metal poles must be galvanized.

## Requirements for Customer-Owned Poles

**Table 1 Approved Suppliers for Permanent Wood Poles (Table 5, Item 2 on Page 7) <sup>1</sup>**

Service Poles 35 Feet and Shorter	Distribution Poles Taller than 35 Feet
Koppers	Stella Jones – SJC / McFarland Cascade – MCF (Tacoma, WA. or Eugene, OR. Yards only)
Silver Springs, NV. Stella Jones – SJC / McFarland Cascade – MCF	
Thunderbolt Wood Treating	

<sup>1</sup> Service poles are sold to lumberyard/hardware companies.

**Table 2 Approved Service Pole Treatments <sup>1</sup>**

Species	Treatment			
	Penta-A Pressure (Oil-Penta) (PA)	Ammoniacal Copper Zinc Arsenate (ACZA or SZ)	Creosote (C)	Chromated Copper Arsenate (CCA or SK)
Western Red Cedar	X	X	X	X
Douglas-Fir	X	X	X	–
Northern Red Pine (NP) <sup>2</sup>	X	–	–	–

<sup>1</sup> All poles must be full-length treated, except Western Red Cedar may be butt treated with oil pentachlorophenol.

<sup>2</sup> The Northern Red Pine poles are only allowed as customer owned service poles 35 feet and shorter.

**Table 3 Pole Setting Depths**

Pole Length (feet)	Setting Depth (feet)	
	Firm Soil	Rock
25 <sup>1</sup>	5-1/2	3
30	6	3
35	6-1/2	3-1/2
40	7	3-1/2
45	7-1/2	4

<sup>1</sup> Do not use a 25 foot pole when the service crosses a street, road, or traveled dirt thoroughfare in agricultural areas. Use a taller pole that allows the minimum clearances to be met.

**Table 4 Customer's Service Attachment Location <sup>1, 2</sup>**

Panel Rating (amps)	Weatherhead Distance From Top of Pole (inches)		PG&E Service Attachment (type)
	Minimum	Maximum	
< = 225	18	20	Service Knob
226-400 (1-Phase) <sup>3</sup>	34	36	3 Spool & Clevis <sup>4, 5, 6</sup>
226-400 (3-Phase) <sup>3</sup>	42	44	4 Spool & Clevis <sup>4, 5, 6</sup>

<sup>1</sup> All open wire services require vertical construction. See Figure 7 on Page 11 and Figure 4 on Page 9.

<sup>2</sup> A longer pole may be necessary to obtain the required service clearances from the ground. See note 9D on Page 4.

<sup>3</sup> See Note 26 on Page 6.

<sup>4</sup> See Figure 7 on Page 11. PG&E service must be insulated wire.

<sup>5</sup> The installation of extended rack brackets is not allowed. Use Vertical construction.

<sup>6</sup> A properly installed and PG&E approved crossarm may be allowed instead of spool and clevis attachments.

### Requirements for Customer-Owned Poles

#### Vertical Clearance for Service Poles

9. Conductors to service poles must have a minimum ground clearance as follows:

- A. Over the center portion of the street, 18' 0" minimum. For conductor height over trolleys, railroad tracks, telephone lines, etc., consult PG&E.
- B. At the curb or outer limits of possible vehicular traffic, 16' 0" minimum.
- C. Over private driveways, lanes, or other areas accessible to vehicles used for industrial, commercial, or agricultural purposes, 16' 0" minimum.
- D. **If required clearances cannot be obtained with a minimum-length service pole and the constructions illustrated on Pages 7 through 9, the required clearances should be obtained by using a longer (taller) pole.** The setting depth for a 25-foot and longer pole must be followed as specified in Table 3 on Page 3.

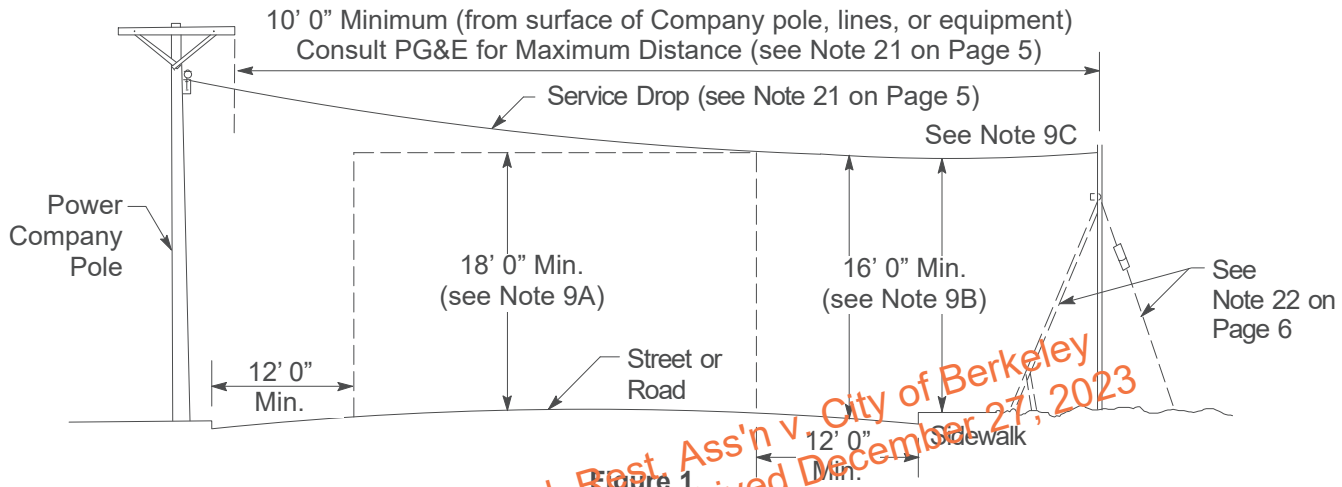


Figure 1  
Clearances for Service Poles

#### Service Entrance Conductors

- 10. The customer must furnish, install, and maintain the service entrance wiring and service equipment beyond the point of attachment to PG&E's service wires. The service entrance wires must be continuous and must be of a size and type that will provide not less than the minimum standard of safety as specified in local city and county ordinances or, where there is no local ordinance, as specified in the current issue of the National Electrical Code (NEC).
- 11. The neutral conductor of 2-wire, 120 V and 3-wire, 120/240 V (or 120/208 V) services must be securely connected to the neutral terminal of the meter socket and extended through to the neutral terminal of the service entrance switch. It must be continuous (without splice) from the service head to the service entrance switch.
- 12. At least 18 inches of service entrance conductors must be provided outside the service head.
- 13. Weatherproof wire is not permitted in conduit.

## Requirements for Customer-Owned Poles

### Service Entrance and Load Side Conduit and Conduit Covering

14. Service entrance and load side conduit and conduit covering requirements must comply with applicable codes and local requirements. [G.O. 95](#) requires that any conduit installed **below** the 8-foot level on the pole must be treated as a riser; in which case, the conduit must be either rigid galvanized steel or 2-inch minimum diameter Schedule 40 PVC.

**Exception:** Conduit that enters the top of an enclosure is considered to be “protected” by the enclosure and need not be treated as a riser unless installed below the 6-foot level. Conduit installed above the 6-foot or 8-foot level (whichever height applies) must be either: (1) galvanized rigid steel conduit, (2) rigid aluminum conduit, (3) electrical metallic tubing, (4) IMC, or (5) PVC plastic conduit having a minimum wall thickness of 0.15 inches (Schedule 40 for 2-inch PVC conduit or larger, Schedule 80 for 1-1/2-inch or smaller). All fittings must be rain-tight. If PVC plastic conduit is used, it need not be covered. If rigid steel or other approved metallic conduit is used, it must be enclosed with PVC “U” shaped molding for a minimum distance of 8 feet below the lowest open service entrance conductor. The covering must be fastened to the pole at intervals not greater than 3 feet (see Page 11).

15. Wood Block:

A. A wood block must be attached directly over the service head in the following situations:

- (1) On a service pole where electrical metallic tubing, rigid steel, or IMC is used.
- (2) On a wood pole with plastic conduit installation when the service head is metallic and the neutral service entrance conductor is not insulated.

B. A wood block over the service head is not required in the following instances:

- (1) On a service pole with plastic conduit installation except as noted in Note 15, A. above.
- (2) On a metallic pole, provided the pole is effectively grounded and provided all metallic conduits are adequately bonded to the metal pole with approved clamps or connectors.

C. Attach wood blocks as shown on Pages 8 through 10.

16. All conduit and fittings must be rain-tight.

17. Water pipe and fittings are not permitted for use as electrical conduit.

### Service Entrance Switch

18. Main switch, receptacles, and other equipment on the load side of the meter must be of weatherproof design or protected by weatherproof enclosures. Such equipment must comply with local ordinances and must also comply with the California Building Standards Code - Electrical Regulations.

19. The switch cover must be locked if the enclosure contains exposed live parts.

### Grounding

20. The customer must be responsible for bonding and grounding all exposed, non-current-carrying metal parts. Grounding and bonding must be in accordance with NEC and local ordinances. PG&E prefers, but does not require, the grounding electrode conductor wire to be protected against physical damage by rigid steel conduit or armored cladding (see Pages 8 and 10 for additional details).

### Pole Location

21. Poles must be located so that the vertical clearances specified in Note 9 and Figure 1 on Page 4 can be obtained. A service pole must not be located less than 10 feet from the surface of the PG&E pole, or pole-mounted equipment, or within 10 feet of the vertical plane of a PG&E line.

PG&E must be consulted for maximum span lengths, as they can vary depending on wire type and size, loading area, clearances, and suitable guying. The maximum span length of PG&E's service drop to a temporary pole must not exceed 100 feet, and if 4/0 conductor is necessary, not more than 80 feet. The maximum span length for a permanent type installation may vary from 80 feet to 150 feet upward depending on the variables mentioned.

The pole must also be positioned so that the pole brand will not be hidden by the main service switch, meter socket box, or conduit runs.

**Requirements for Customer-Owned Poles****Guying or Bracing**

22. Where conductors cross, a public or private paved street or road, a traveled dirt thoroughfare in agricultural areas, or poles set in areas with soft soil, as determined by PG&E, the customer's pole must be guyed or braced against the pull of conductors as follows:
- Temporary Poles: Anchor guy as shown in Figure 13 on Page 12, or with wood braces not smaller than 2" x 4" timber and securely bolted to the pole as per Figure 14 on Page 12. See Figure 2 on Page 8 for the correct placement of guy or brace.
  - Permanent Service Poles: Anchor guy only as shown in Figure 13 on Page 12. See Figure 5 on Page 10 for the correct placement of guy.
  - The guy strain insulator is to be located in a zone: 8 feet or more above the ground; and 8 feet or more below the level of the lowest supply conductor, or 6 feet or more from the surface of the pole and 1 foot or more below the level of the lowest supply conductor.

**Metering Requirements**

23. Meters must be furnished by PG&E. See Greenbook sections 5, 6, and 7 for meter panel and additional metering requirements.
24. For residential installations, meter sockets without test bypass facilities must be furnished, installed, and wired by the customer as shown on Page 12.
25. For commercial and industrial applications, meter sockets with PG&E-approved test bypass facilities must be furnished, installed, and wired by the customer.
26. Customer-owned poles for residential use are limited to only one meter panel rated at 225 amps (continuous) or less. Poles for non-residential applications are limited to only one meter panel rated at 200 amps or less. Residential and Non-residential installations with more than one meter, or a meter panel with a greater ampacity must be installed on panelboard construction as shown in Document 025874. Electric meter panels with a circuit breaker section attached to the right or left side of the meter section, may be required, as determined by PG&E, to provide additional support for the panel on the pole.

**Verifying Depth of Customer Owned Poles**

Applicants who plan to install a new customer-owned service pole prior to inspection by PG&E personnel can use following method for PG&E inspectors to verify the setting depth of newly installed poles that have already been set in the ground. See notes below and Figure 18, "Pole Depth Verification", on page 17. These installations will be approved at the discretion of the PG&E Electrical inspector.

- Install 3/4-inch diameter PVC Schedule 40 conduit from the bottom of the pole to 12 inches above grade level.
- Place a removable cap on the top of the conduit and a permanent cap on the bottom of the conduit.
- Attach the conduit to the pole using three heavy duty pipe straps and 10D galvanized nails. Place one pipe strap towards the top of the conduit below the removable cap. Place the second strap in the middle of the conduit and the third strap at the bottom of the conduit just above the permanent cap.
- Install a PG&E approved pole to, at least, the minimum required setting depth. Refer to Table 3 Pole Setting Depths on page 3.
- Ensure the PVC conduit is not broken and remains free of soil, equipment, or other obstacles, throughout the conduit. The conduit will be used to verify the pole setting depth.
- Backfill and compact the soil around the pole to 90% of maximum density. Determine the maximum density and the in-place density by the California Test Method No. 216-6, Parts I and II respectively, or by ASTM D-1556 and D-1557 respectively. A copy of the test results may be required by PG&E.
- Call for inspection after the installation of the customer owned pole is complete.

## Requirements for Customer-Owned Poles

**Table 5 Materials to Be Furnished and Installed by the Customer**

Item	Description
1	Pole, 6" x 6" Timber, Class 6 Round, or Equivalent Metal (length as required, see Note 2 on Page 1)
2	Pole, Wood, or Equivalent Metal (see Note 6, Note 7, and Note 8 on Page 2). (See Table 1 on Page 3 for approved list of wood pole suppliers.)
3	Meter Socket, Main Service Switch
4	Conduit, Service (see Note 14 on Page 5)
5	Conduit, Load Side (see Note 14 on Page 5)
6	Conduit Fitting, Threaded, With Cover and Gasket
7 <sup>1</sup>	Covering, PVC Conduit, or PVC Moulding (see Page 9)
8 <sup>1</sup>	Wood Block (4" x 4" x 6" or two 2" x 4" x 6" nailed together)
9	Service Head
10	Service Knob
11	Wire, Insulated (size as required) (18" minimum extension from service head)
12	Bolt, Machine, 5/8 or 3/4, (as required), Galvanized
13	Washer, Curved, 3" x 3" (for 5/8" Bolt) or 4" x 4" (for 3/4" Bolt), Galvanized
14	Guy Hook or Guy Pole Plate and Thimble Assembly
15	Guy Strand Cable, 7/32" or 1/4" Minimum Galvanized Steel or Equivalent
16	Insulator, Guy Strain (10,000 lbs. minimum)
17	Guy Grip, Preform, (as required)
18	Anchor Rod, 5/8" x 6' 0" Minimum, and Fittings (as required)
19	Anchor, 16" Cross Plate, or 8" Expanding
20	Guy Marker
21	Push Brace, 2" x 4" Minimum Timber, securely bolted to pole). See Figure 14 on Page 12.
22	Grounding by Customer (see Pages 8 and 16)

<sup>1</sup> Omit conduit covering, Item 7, and wood block, Item 8, on a metal pole or on a wood pole with plastic conduit (see Note 15 on Page 5). **Exception:** The wood block is required for a wood pole with plastic conduit when the service head is metallic and the neutral service entrance conductor is uninsulated (see Note 15 on Page 5).

**Table 6 Materials to Be Furnished and Installed by PG&E**

Items	Description	Document
23	Vertical Construction	-
24	Spool and Clevis	<a href="#">022439</a>
25	Meter, Watthour (as required)	-
26	Service Wire (as required)	<a href="#">059626</a>
27	Insulator, for Service Wire (as required)	<a href="#">025202</a>
28	Connectors, Service Sleeve (as required)	<a href="#">028852</a>
29	Preformed Grip, Dead-End (as required)	<a href="#">028851</a>



### Requirements for Customer-Owned Poles

### Temporary Installations

#### Notes

1. Locate the guy in line with the service drop. The guy must be maintained taut.
2. Grounding and bonding, by the customer, must be in accordance with NEC and local ordinances, (see Note 20 on Page 5). The ground rod must be located no less than 12 inches from the pole surface.
3. Customer's equipment must not be installed in the climbing space or over the pole brand. See Note 20 on Page 5 for grounding requirements.
4. For customer-owned poles, span lengths are limited to 100 feet. The vertical separation between conductors in vertical construction is 8 inches minimum.
5. If the poles are to be set in **firm** soil, use the setting depths from the "Firm Soil" column of Table 3 on Page 3. If the poles are to be set in **rock**, use the setting depths from "Rock" column of Table 3 on Page 3. If the poles are to be set in **soft** soil, the poles must be set deeper than the depths shown in Table 3. Consult the PG&E project coordinator for the other approved methods for **soft** soil.

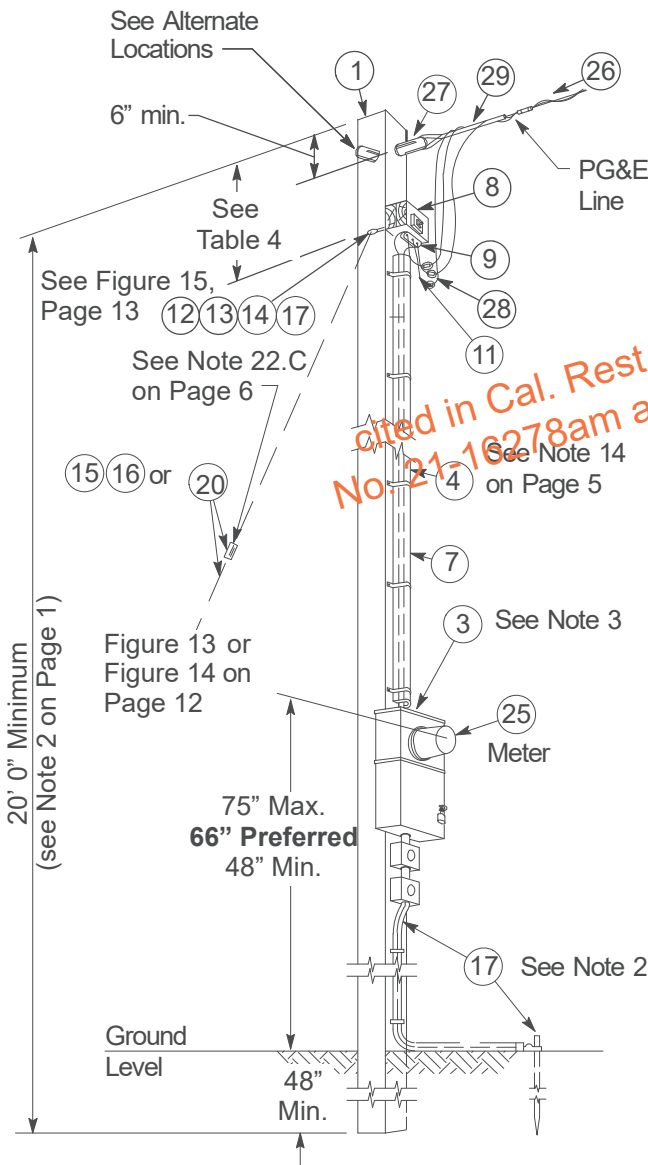


Figure 2  
Service Drop Cable to Receptacles

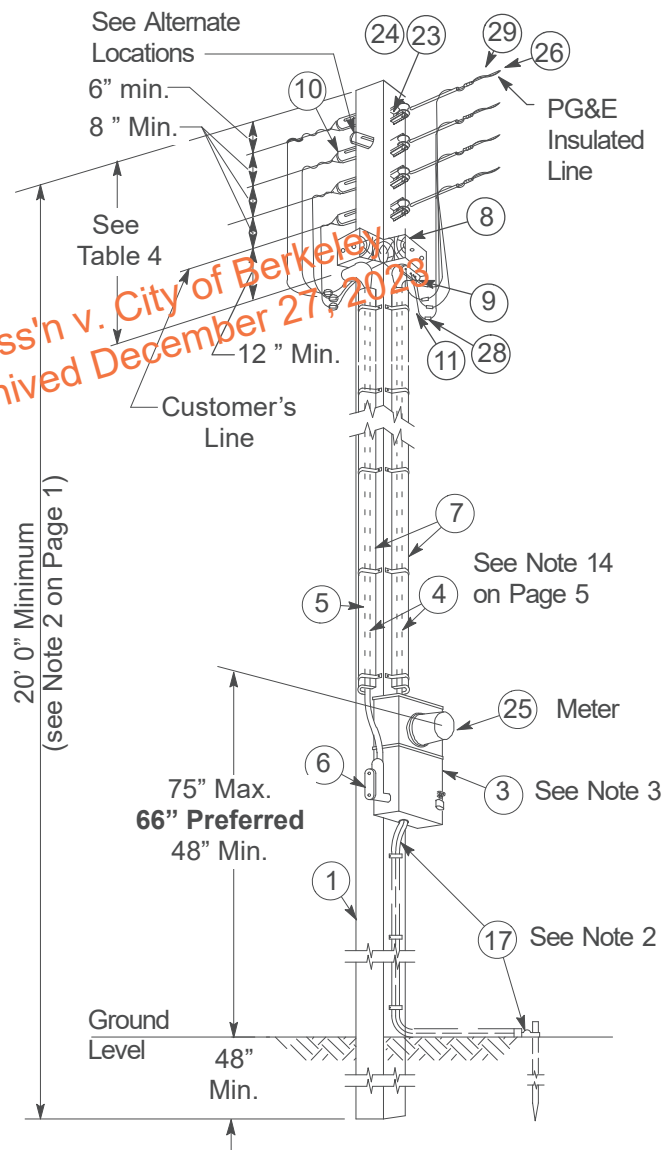
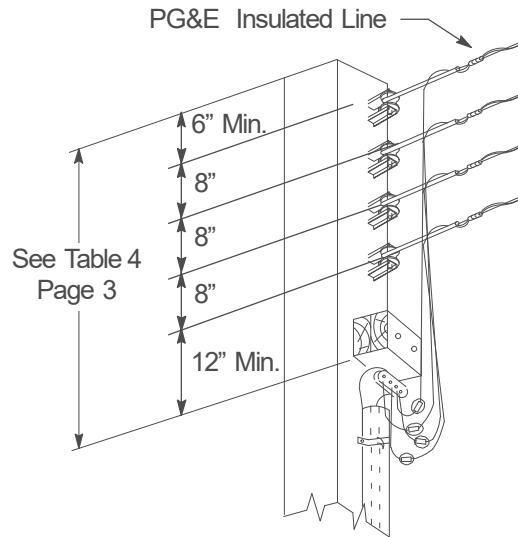


Figure 3  
Service Drop Cable to Overhead Line

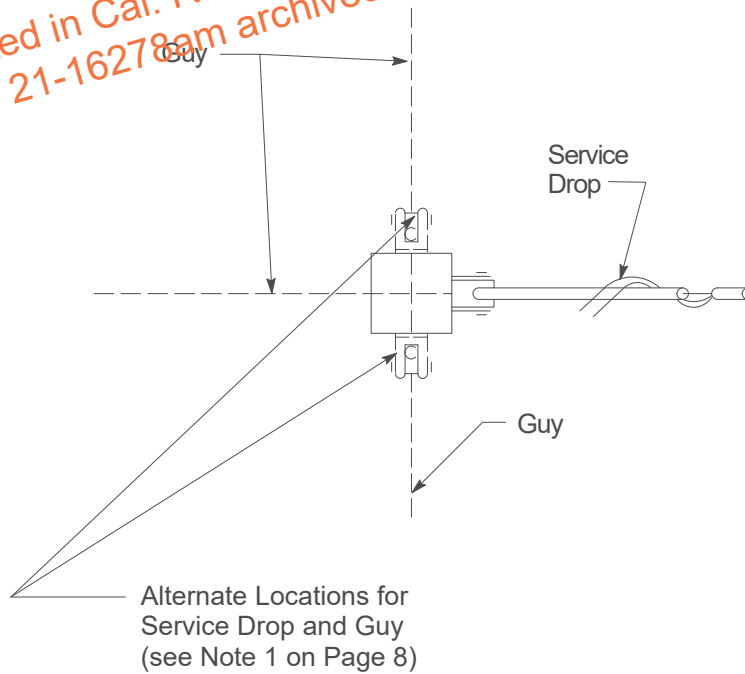
### Requirements for Customer-Owned Poles

#### Temporary Installations (continued)



**Figure 4**  
**Open Insulated Wire Construction**  
 (For use when the load requires a larger service drop conductor)

*cited in Cal. Rest. Ass'n v. City of Berkeley  
 No. 21-16278am archived December 27, 2023*



**Detail A**  
 See Figure 16 on Page 14

### Requirements for Customer-Owned Poles

#### Permanent Installations

##### Notes

1. Locate the guy in line with the service drop. The guy must be maintained taut.
2. Grounding and bonding, by the customer, must be in accordance with NEC and local ordinances (see Note 20 on Page 5), The ground rod must be located no less than 12 inches from the pole surface.
3. Customer's equipment must not be installed in the climbing space or over the pole brand. See Note 20 on Page 5 for grounding requirements.
4. For customer-owned poles, span lengths are limited to 150 feet. The vertical separation between conductors in vertical construction is 8 inches minimum.
5. If the poles are to be set in **firm** soil, use the setting depths from the "Firm Soil" column of Table 3 on Page 3. If the poles are to be set in **rock**, use the setting depths from "Rock" column of Table 3 on Page 3. If the poles are to be set in **soft** soil, the poles must be set deeper than the depths shown in Table 3 on Page 3. Consult the PG&E project coordinator for the other approved methods for **soft** soil.

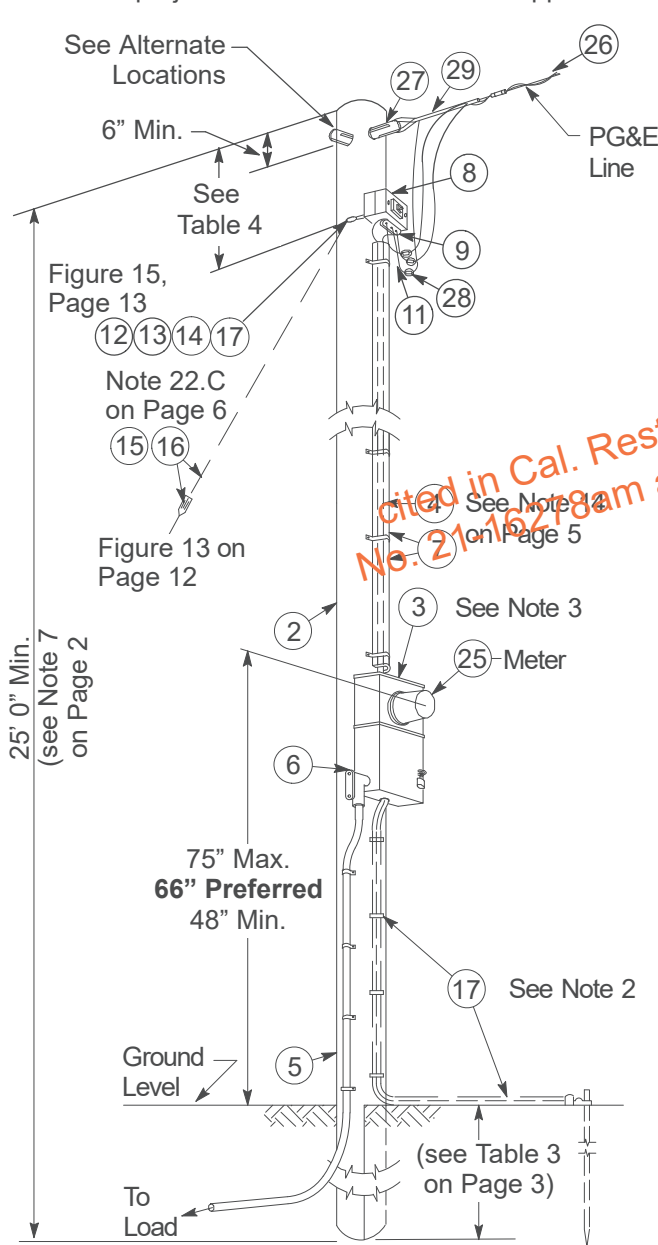


Figure 5  
Service Drop Cable to Underground Line

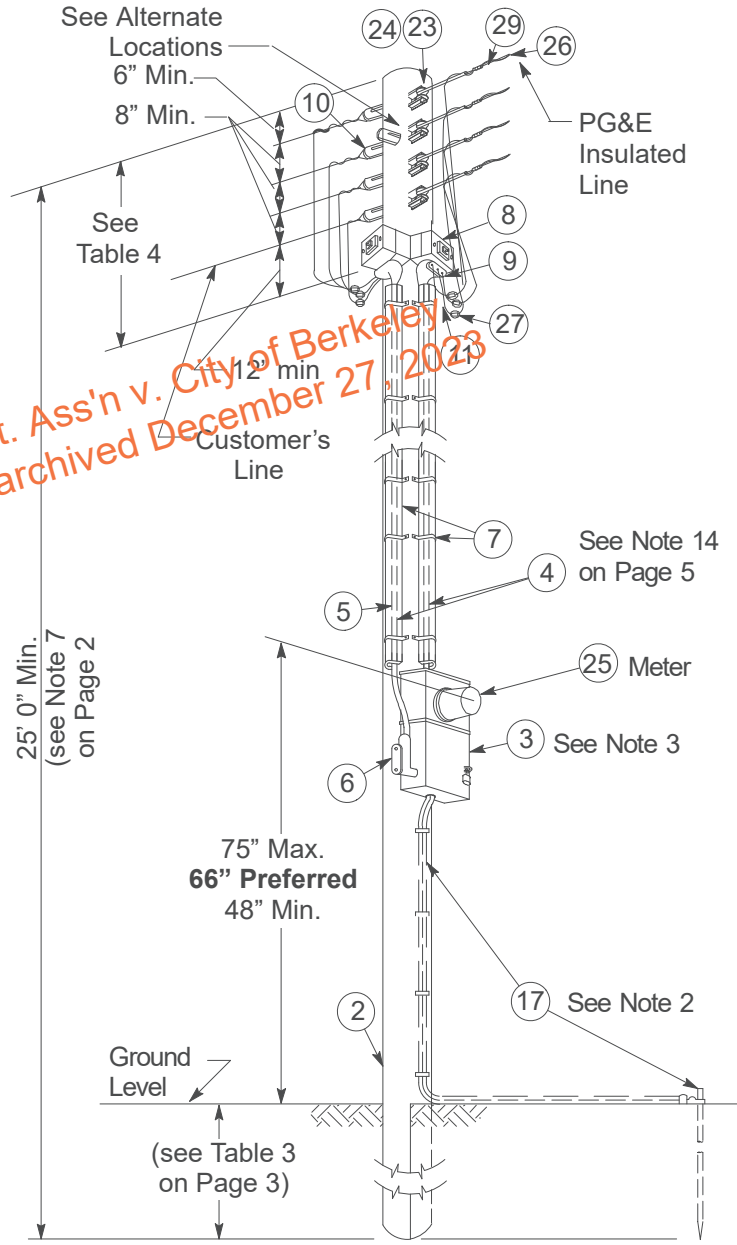
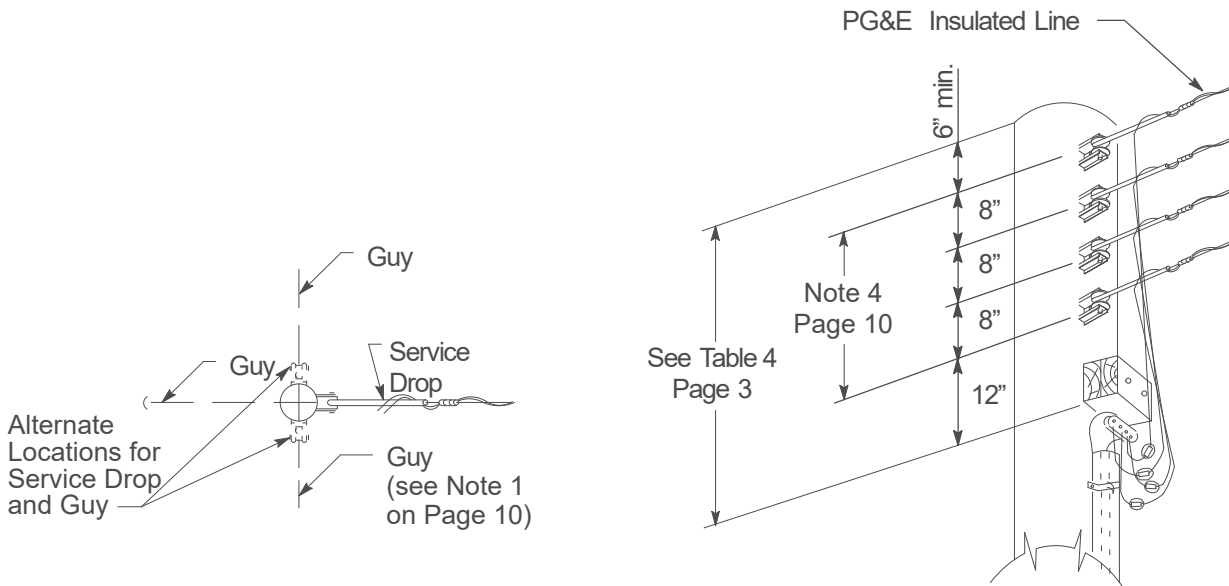


Figure 6  
Service Drop Cable to Overhead Line

*cited in Cal. Rest. Ass'n v. City of Berkeley  
No. 21-16278am archived December 27, 2023*

**Requirements for Customer-Owned Poles**

**Permanent Installations (continued)**



**Detail B**  
 See Figure 5 and Figure 6 on Page 10

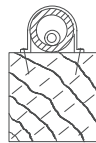
**Figure 7**  
**Open Insulated Wire Construction**  
 (for use when the load requires a larger service drop conductor)

*cited in Cal. Rest. Ass'n v. City of Berkeley  
 No. 21-16278am archived December 27, 2023*

**Method of Covering Metal Conduits and Attaching Coverings on Wood Poles**

**Notes**

1. Strap PVC conduit to the pole with 2-hole heavy duty pipe straps or galvanized perforated plumber's tape spaced not more than 3 feet apart (see Figure 8).
2. Attach PVC molding to the poles with 1/4" x 2-1/2" galvanized washer-head lag screws.



**Figure 8**  
**PVC Conduit**  
 (see Note 1)

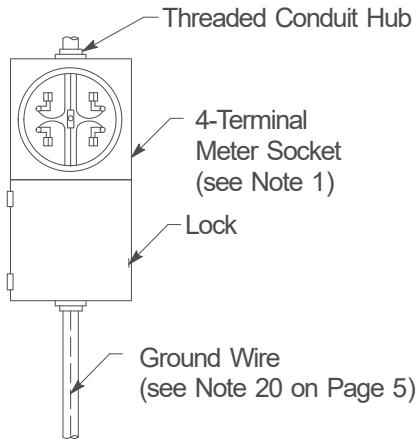


**Figure 9**  
**PVC Molding**  
 (see Note 2)

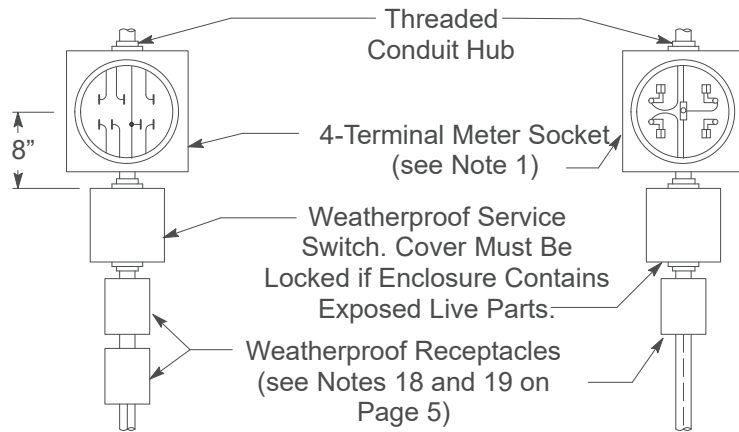
### Requirements for Customer-Owned Poles

#### Meter Connections

1. For test bypass facilities, see Note 25 on Page 6.
2. All wiring material on the load side of the meter socket must be in accordance with applicable electrical codes, city and county ordinances, and must comply with the California Building Standards Code – Electrical Regulations. Unless threaded connections are used, adequate bonding of all sections of the service equipment must be provided.



**Figure 10**  
120/240 V, 3-Wire  
With WHM, Service  
Switch, and Receptacle in  
Weatherproof Cabinet  
(see Note 2)

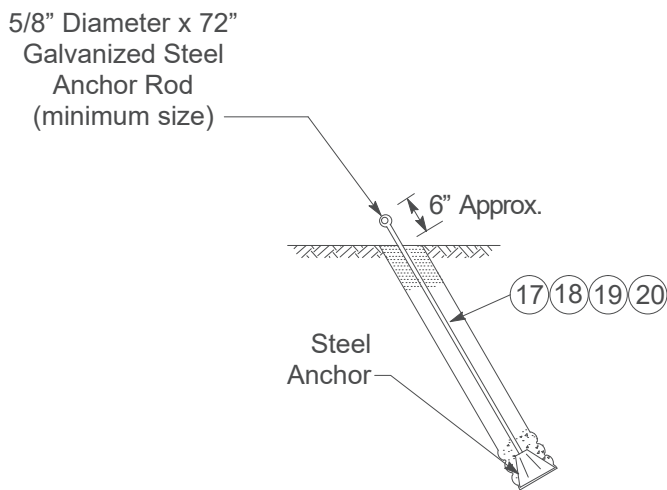


**Figure 11**  
120/240 V, 4-Wire Delta  
With Weatherproof Service  
Switch and Receptacles  
(see Note 2)

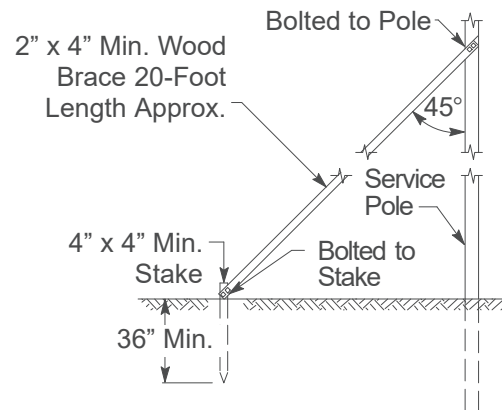
**Figure 12**  
120/240 V, 3-Wire  
With Weatherproof Service  
Switch and Receptacles  
(see Note 2)

*cited in Cal. Res. Ass'n v. City of Berkeley  
No. 21-16278am archived December 27, 2023*

#### Details of Anchors, Guying Materials, and Brace



**Figure 13**  
Steel Anchor



**Figure 14**  
Wood Brace  
(for use with temporary pole only)

**Note:** Use 1/2 Galvanized Machine Bolts, and 1" x 1" Diameter Curved Washers to attach wood brace to stake and pole.

## Requirements for Customer-Owned Poles

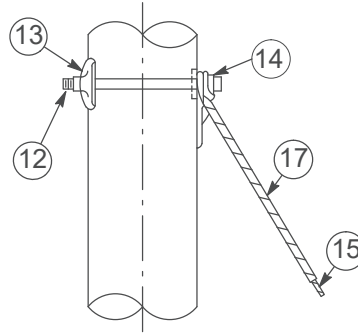


Figure 15  
Guying Materials

### Temporary Commercial Service to Non-Substantial Portable Structure

#### Notes

##### 1. Temporary Service Attachment

Temporary services will not be directly attached to any structure considered by PG&E to be of inadequate strength. The structure must, in all cases, be **substantial** (see Note 2) and capable of supporting the service span, as well as the force of the ladder and worker against the service mast.

##### 2. Portable Buildings (Figure 16 on Page 14 and Figure 17 on Page 16)

Portable buildings, such as small sheds, combined office/toilet structures, etc., are not considered to be **substantial** structures unless they are staked in place in the manner shown in Figure 17 on Page 16. Furthermore, periscopes must be installed and adequately braced in accordance with Figure 17 on Page 16 and the "Electric Service: Overhead" Section of the [Electric and Gas Service Requirements Manual](#) (Greenbook).

##### 3. Temporary Poles (Figure 16 on Page 14)

Customer-owned temporary poles are required for support of PG&E's overhead service wires if the temporary building to be served is considered by PG&E as **not substantial**.

##### 4. Method of Serving

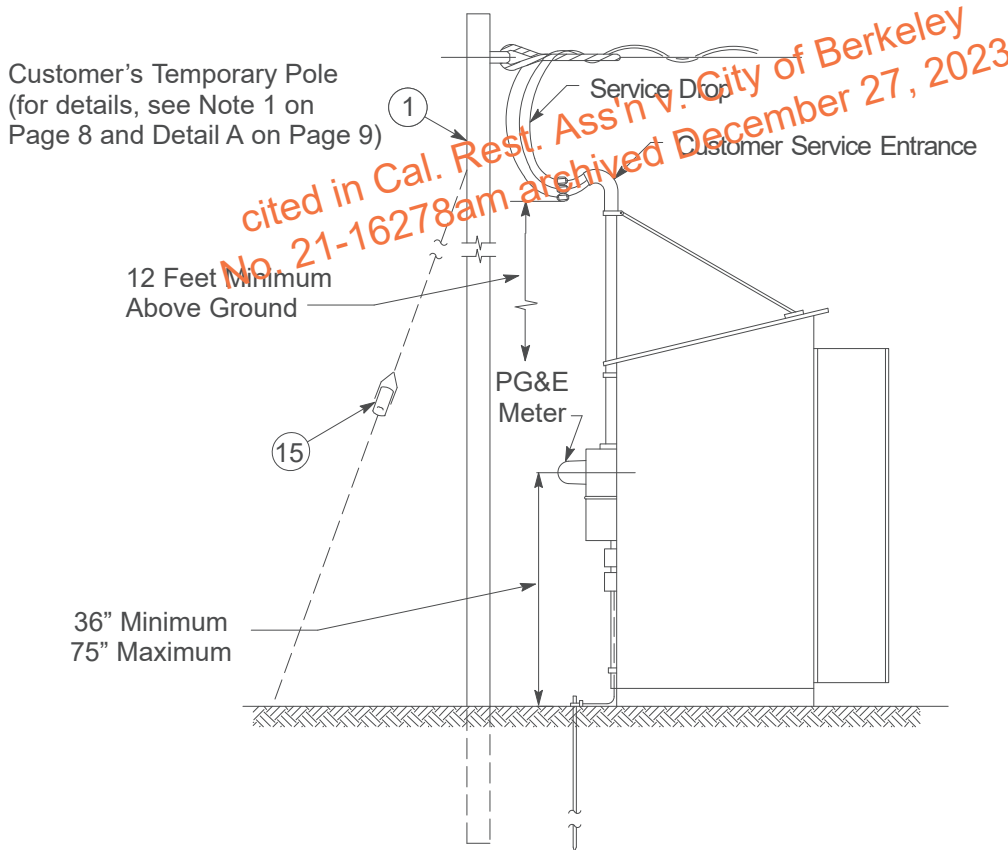
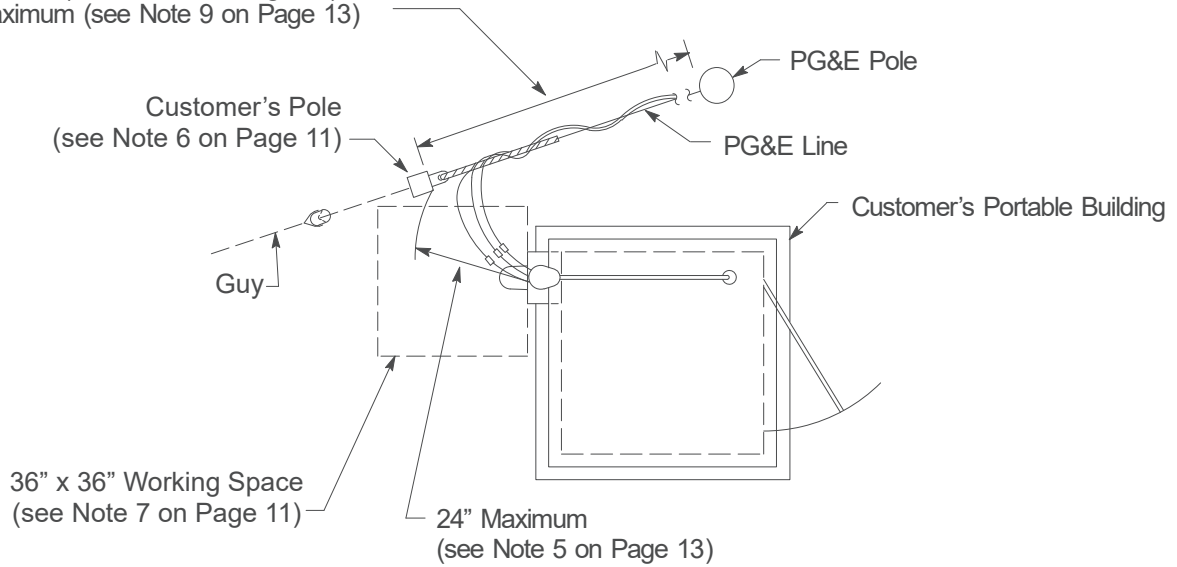
Non-substantial structures that have been approved for the attachment of metering equipment and service periscopes may be served in the manner shown on Page 14. However, if desired, the metering equipment may be removed from the structure and placed on the temporary pole as shown in Figure 2 on Page 8.

5. The distance from the centerline of the periscope service mast to the pole face must not exceed 24 inches.
6. A portable structure must not obstruct the climbing space of a temporary pole.
7. The working space in front of the meter must not be obstructed.
8. The minimum distance from the surface of a PG&E pole to a customer's pole is 10 feet.
9. The maximum permitted span to a PG&E pole is 100 feet and may be only 80 feet in some cases (see Note 21 on Page 5).

### Requirements for Customer-Owned Poles

#### Temporary Commercial Service to Non-Substantial Portable Structure (continued)

10 Feet Minimum (see Note 8 on Page 13)  
100 Feet Maximum (see Note 9 on Page 13)



**Figure 16**  
**Portable Structure (non-substantial)**  
(see Note 2 on Page 11)

## Requirements for Customer-Owned Poles

### Temporary Commercial Service to Substantial Portable Structure

#### Notes

1. Substantial Building

See Note 2 on Page 13 for an explanation of a “substantial” portable building.

2. Structure Anchoring

To prevent overturning, the structure is required to be securely anchored in place using one of the following methods:

- A. Four 2” x 4” minimum wood stakes driven a minimum of 24 inches into the ground and attached to the framework of the structure using 1/4-inch minimum bolts or lag screws.
- B. Four steel stakes having strength equivalent to 3/4-inch rigid steel pipe driven a minimum of 24 inches into the ground and attached to the framework of the structure using 1/4-inch minimum bolts or lag screws.
- C. Four steel stakes having strength equivalent to a 3/4-inch rigid steel pipe driven a minimum of 24 inches into the ground with a cross member of each stake firmly contacting the upper surface of the timber used as a base or skid for the structure.

**Note:** Methods 2A and 2B above describe the **preferred** methods of attaching the stakes to the structure framework. However, four 16d (8-gauge, 3-1/2-inch) common nails per stake may be used in lieu of the bolts or lag screws, providing the wood is in good enough condition to permit a secure attachment.

3. Periscope Mast Bracing

Two galvanized steel braces, securely bolted or lagged to the structure’s framework with approximately a 90° spread, must be installed. Use 3/4-inch galvanized rigid steel pipe or 1-1/4” x 1-1/4” x 1/8” galvanized steel angle (minimum size).

4. Service Disconnection

When initial service is disconnected, sufficient service drop cable should be left connected to the service entrance cable to permit the future splicing of service cable from the ground level. This practice will limit the need for placement of ladders against the periscope mast when the structure is moved to a new location.

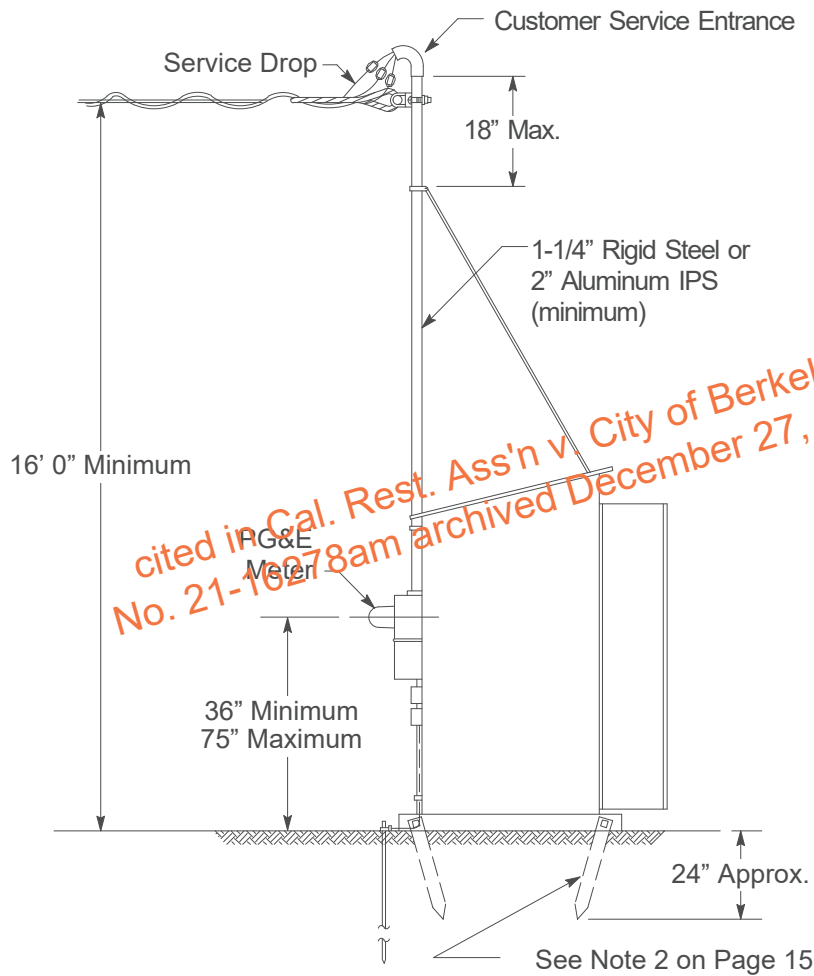
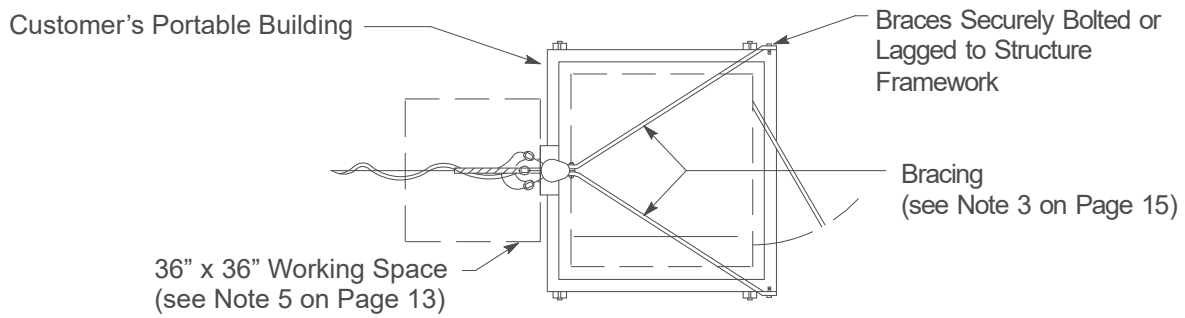
5. The working space in front of the meter must not be obstructed.

6. For temporary underground commercial service to substantial portable structures, see [Document 036670](#).



### Requirements for Customer-Owned Poles

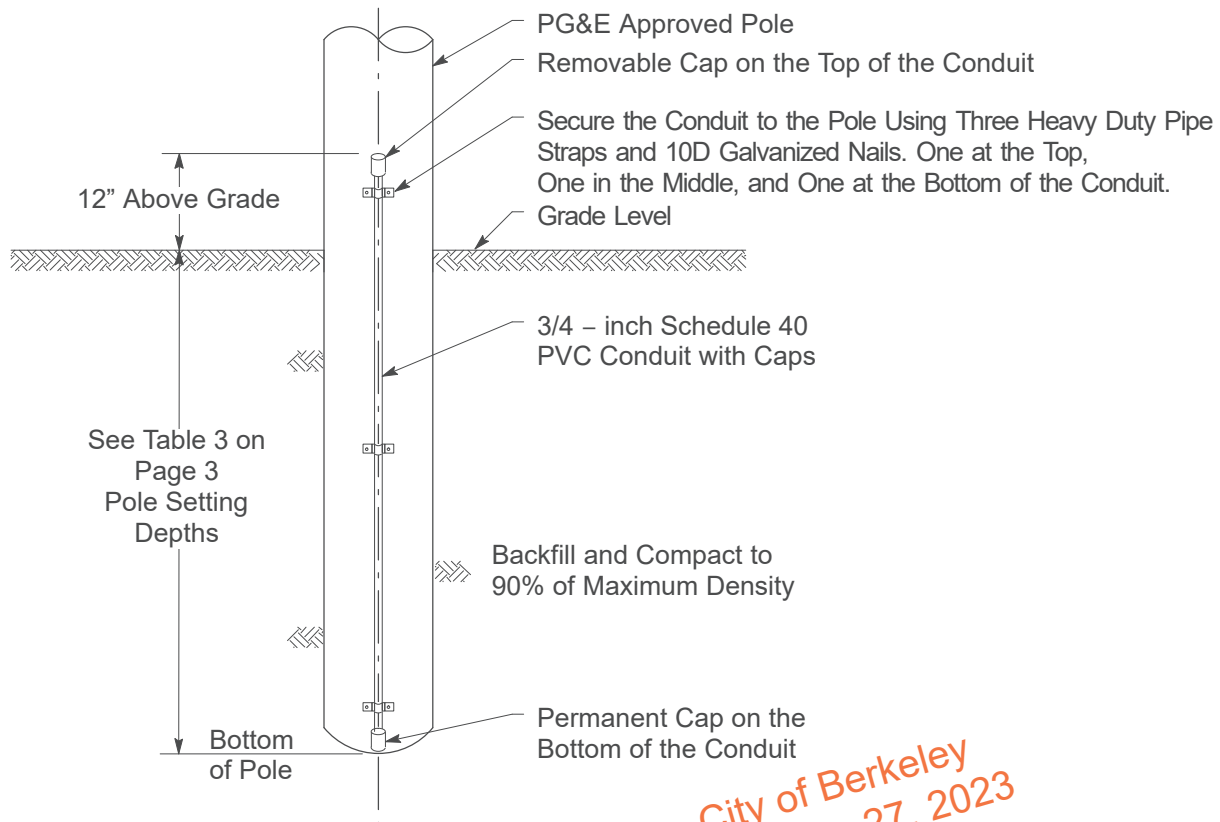
#### Temporary Commercial Service to Substantial Portable Structure (continued)



*cited in Cal. Rest. Ass'n v. City of Berkeley  
No. 21-16278am archived December 27, 2023*

**Figure 17**  
**Portable Structure - Substantial**  
(see Note 2 on Page 13)

## Requirements for Customer-Owned Poles



**Figure 18**  
**Pole Depth Verification**

*cited in Cal. Rest. Ass'n v. City of Berkeley  
No. 21-16278am archived December 27, 2023*

**Revision Notes**

Revision 20 has the following changes:

1. Updated note 7.E. on Page 2 regarding setting depths.
2. Updated Table 2 on Page 3.
3. Updated Footnote 1 in Table 3 on Page 3 to include, traveled dirt thoroughfare in agricultural areas.
4. Added Footnote 6 in Table 4 on Page 3 to allow properly installed and PG&E approved crossarms instead of spool and clevis attachments.
5. Updated Note 22 on Page 6 requiring an anchor and guying for where conductors cross a traveled dirt thoroughfare in agricultural areas, or poles set in areas with soft soil.
6. Updated Note 22 on Page 6 stating that single metered panels with a circuit breaker section may be required to provide additional support for the panel on the pole.
7. Removed the old minimum pole setting depth shown in Figure 5 and Figure 6 on Page 10.

cited in Cal. Rest. Ass'n v. City of Berkeley  
No. 21-16278am archived December 27, 2023

Prepared by: SXZO

	<b>INSTALLATION DETAILS FOR SERVICE TO POLE-MOUNTED COMMUNICATION EQUIPMENT</b>		<b>027911</b>
	<b>Asset Type:</b> Electric Distribution	<b>Function:</b> Construction	
<b>Issued by:</b> Daniel Jantz (DWJ7)		<b>Date:</b> 3/25/2022	
<b>Rev. #14:</b> This document replaces PG&E Document 027911, Rev. #13. For a description of the changes, see Page 15.			

**Purpose and Scope**

This document illustrates the minimum design and construction requirements for providing service, supplied from overhead facilities, to non-PG&E owned antenna and communication equipment installed above or below supply lines (primary, secondary or service) on PG&E or joint distribution wood poles and wood streetlight poles.

**General Information**

1. **The preferred location for antennas to be installed is in the communication zone on the pole and not the top of the pole. Only service connections and arrangements described and shown in this document are approved design installations. Alternate connections, arrangements, or designs will not be allowed.**
2. For the design and construction requirements for antenna and communication equipment installed on PG&E or Municipal owned steel streetlight poles, or 3rd party owned wood poles, served from an underground or overhead service, refer to 094677, 094678 and 094679 listed in the reference documents on Page 3.
3. **It is the responsibility of the constructor to ensure the antenna installation meets the requirements of PG&E and CPUC General Order 95.**
4. Before installation, the location of the equipment and the vertical run are to be mutually agreed upon between representatives of the communication company and PG&E.
5. **3rd party (non-PG&E) owned antennas and communication equipment are not allowed to be installed on poles that have PG&E distribution equipment installed and connected to the primary voltage lines. This includes the top of the pole and the communication zone. This will reduce interference on poles and allow for quicker and safer access during emergency work for the operation and replacement of equipment.**

Distribution equipment includes primary risers, cutouts, fuses, switches, transformers, capacitors, regulators, as well as any other type of equipment not listed here that is connected to the overhead primary lines.

6. Primary voltage lines with triangular construction provide a safer work environment, more reliable system, and reduces the threats of fire ignition, by increasing the separation of the wires and installing them at different levels. For these reasons, **of the design and installation of antennas on existing pole tops where the primary voltage lines are built with triangular construction are not allowed.** A pole nearby that has all wires on a crossarm (flat construction) or a streetlight pole may be selected.
7. Stand mounted antennas or antennas embedded in or attached to communication cables and messengers must have a minimum radial clearance of 6 feet from the edge of the pole. If the Minimum Approach Distance (MAD) for the antenna is greater than 3 feet than the radial clearance must be increased.
8. SmartPole Metering is required for service. Refer to 094675 listed in the reference documents on Page 3 for the SmartPole metering options and requirements. For loads that exceed 100 amps contact the local service planning office for alternate metering requirements.
9. The metering provision contained herein is an exception to the Greenbook requirement and is designed primarily for CATV power supplies and other telecom equipment requiring metering.
10. The metering equipment must be mounted on the same pole as the PG&E service, antenna, and communication equipment. **Remote metering is not allowed.**
11. When pole metering is unacceptable because it does not meet the PG&E criteria and requirements, the alternative method is to install approved pad-mounted pedestal metering served from a PG&E underground service. Some examples of unacceptable situations include locations:
  - Where access to the meter is impaired.

## Installation Details for Service to Pole-Mounted Communication Equipment

- Where meters may be subject to obvious traffic hazards or unsafe working conditions.
  - Where hillside pole locations render metering unsafe.
  - Where there are only PG&E underground facilities and no overhead primary and secondary distribution facilities.
12. The potential exists for governmental entities to inquire as to metering for traffic or surveillance cameras, or possibly lighting load if mounted on PG&E or joint poles. In all cases, field representatives shall request the telecommunication company to provide documentation that authorizes them to occupy the space on the pole (e.g., contract permit issued by PG&E or joint owner for tenants).
  13. The pole-mounted antenna and communication equipment loads will only be served at single-phase, 2-wire, 120 V or a single-phase, 3-wire, 120/240 V service.
  14. The requirements in this Engineering Document are typically updated annually. The requirements become effective on the date of the publication. New changes may affect the customer's preliminary designs and selected pole location as submitted on their application. This includes application submittals that are up to, or more than, 12 months old. As described in Greenbook section [1.4., Changes in Requirements](#), PG&E may revise its design and construction documents up to the date the applicant's service design is approved and signed-off by PG&E. Applicants that have not been provided a PG&E approved design, or if the approved design is older than 12 months, are subject to newly published requirements.
  15. If changes are made to an existing antenna installation that requires the pole to be replaced for any of the following reasons, then all requirements in this document must be met. Including Note 5 where the antenna would be required to be removed from a pole with distribution equipment connected to the primary lines.
    - A. Pole loading is exceeded.
    - B. Minimum clearances will not be met.
    - C. The PG&E service and SmartPole meter are upgraded to handle a larger capacity due to increased loading.
    - D. The PG&E meter is remote at another location and not attached on the same pole or in a pad-mounted pedestal. Remote meters are not allowed and must be brought to current standards.
  16. Pole steps shall be placed so that runs or risers do not interfere with their free use. Attention is directed to the following requirements of [General Order \(G.O.\) 95](#).
    - A. The position of the climbing space shall not be shifted more than 90° around the pole within a vertical distance of less than 8 feet. Refer to [Rule 93](#) of [G.O. 95](#).
    - B. Vertical runs are not permitted in climbing spaces through conductors in rack construction.
    - C. Vertical runs of supply lines shall have a clearance of not less than 1-1/2 inches from vertical runs of communication lines.
    - D. The coaxial cable leads to and from amplifier units shall not be carried under the same protective covering with the 120/240 V supply conductors. The leads should be carried outside the molding in cable rings. The leads are not required to be covered unless they are within a vertical distance of 3 feet above or 6 feet below unprotected supply conductors.
    - E. The ground wire is required to be covered.
  17. Units shall be fused or otherwise protected against short-circuit currents. A fused switch or circuit breaker, approved for service entrances, is required. Communication type fuses and fuse holders are not satisfactory means of disconnecting the power source.
  18. Power Supply Units: Power supplies, or any amplifier which has or is connected to a backup power supply, must have a disconnecting device to separate it from PG&E's system. Power units are to have the communication company's name and emergency phone number on them.
  19. Antennas: Antennas installed on distribution poles must have an ownership label with a contact number, site identification information, and a disconnect switch which will shut off RF transmission. The disconnect switch is to be used in an emergency when the normal practice of arranged power-down cannot be accomplished. Locate the ownership label above the SmartPole Meter and not greater than 15 feet above grade. See the requirements in item 18.C. Signage, on Page 5.
  20. To ensure proper climbing and working space around poles is maintained a minimum clearance of 4 feet from PG&E poles and metering equipment is required for non-PG&E street signs on posts or poles.

**Installation Details for Service to Pole-Mounted Communication Equipment**

21. Antennas and communication equipment will not be allowed on poles that have permanent non-PG&E street signs attached if the signs restrict the pole climbing space and the working space around metering equipment.
22. Antennas and communication equipment will not be allowed on PG&E poles that are less than 10 feet away from a non-PG&E pole. This includes streetlight and non-streetlight poles.
23. Antennas and communication equipment on a streetlight pole must not block or impede the illumination projecting (throw) from the streetlight fixture (luminaire). For specific requirements see document [TD-092817-B002 Streetlighting Design Restrictions: Mounting Apparatus below Streetlights](#).
24. PG&E meters must not be installed on poles that are in traffic medians or traffic islands where vehicle thoroughfares are on more than one side of the pole. Refer to document [094675](#).

References	Location	Document
<a href="#">"Procedures for Working Around Antennas SmartPole Meter for Service to Pole-Mounted Communication Equipment on PG&amp;E Owned Steel Streetlight Poles with Antenna Provisions PG&amp;E Metering and Service Connections For Non-PG&amp;E Owned Steel Streetlight Poles With Antenna and Communication Equipment PG&amp;E Electric Service and Metering For Communication Company Equipment and Antennas on Non-PG&amp;E Telecommunication Owned Poles Notification of Abnormal Conditions Caused by Third-Party Utility Moldings, Conduits, and Attachments for Use on Wood Poles and Crossarms Requirements for Customer-Owned Poles Compression-Type Connectors for Overhead Distribution and Transmission Fired Wedge Connectors for Primary and Secondary Distribution Lines</a>	<a href="#">TIL</a>	<a href="#">TD-2001P-01</a>
<a href="#">Communication Equipment on PG&amp;E Owned Steel Streetlight Poles with Antenna Provisions</a>	<a href="#">TIL</a>	<a href="#">094675</a>
<a href="#">PG&amp;E Metering and Service Connections For Non-PG&amp;E Owned Steel Streetlight Poles With Antenna and Communication Equipment</a>	<a href="#">TIL</a>	<a href="#">094677</a>
<a href="#">PG&amp;E Electric Service and Metering For Communication Company Equipment and Antennas on Non-PG&amp;E Telecommunication Owned Poles</a>	<a href="#">TIL</a>	<a href="#">094678</a>
<a href="#">Notification of Abnormal Conditions Caused by Third-Party Utility</a>	<a href="#">TIL</a>	<a href="#">094679</a>
<a href="#">Moldings, Conduits, and Attachments for Use on Wood Poles and Crossarms</a>	<a href="#">OH: Risers/ UG-1: Terminations</a>	<a href="#">021924</a>
<a href="#">Requirements for Customer-Owned Poles</a>	<a href="#">OH: Services/Greenbook/EMWP</a>	<a href="#">025055</a>
<a href="#">Compression-Type Connectors for Overhead Distribution and Transmission</a>	<a href="#">OH: Conductors</a>	<a href="#">041010</a>
<a href="#">Fired Wedge Connectors for Primary and Secondary Distribution Lines</a>	<a href="#">OH: Conductors</a>	<a href="#">066194</a>

Filed in Cal. Rest. Ass'n v. City of Berkeley  
No. 21-16278 am archived December 27, 2023

**Design and Construction:**

25. The following requirements apply to antennas installed on solely owned, jointly owned, wood distribution poles.
  - A. Antennas above supply lines: Third party antennas are only allowed above supply lines or at pole top (above supply facilities) under a license agreement and in accordance with the design and construction requirements outlined herein.
  - B. Antennas below supply and/or communication lines: Third party antennas are allowed in or below the communication space on joint use poles in accordance with the design and construction requirements outlined herein. When the requesting party is a member of the NCJPA and requests attachment to a PG&E solely-owned distribution wood pole, that party is required to submit a joint pole preliminary Form 2 intent. When the requesting party is not a member of the NCJPA, they must obtain a license agreement for pole attachments. Refer requests from non-members to PG&E's New Revenue Development Department (NRD).
  - C. PG&E owned antennas: Antennas associated with PG&E's SCADA system or the SmartMeter™ project shall be installed in accordance with the applicable engineering documents; [054422](#) PG&E Overhead SCADA and PDAC Installation, [068190](#) Antenna and DCU Installation Details for SmartMeter™ Network, [072145](#). SmartMeter™ Electric SSN Network Nodes on Distribution Infrastructure.
  - D. Third party antennas are not allowed on streamline poles. PG&E owned antennas are allowed on streamline poles on an exception basis when no other options are available.
  - E. Any antenna communication equipment or combination of equipment that exceeds 18" in height must be stood off a minimum of 4" from the surface of the pole to facilitate climbing.

## Installation Details for Service to Pole-Mounted Communication Equipment

### 26. Design and Construction Requirements for 3<sup>rd</sup> Party Antennas on Distribution Poles; Above or Below Supply Lines.

The following requirements apply to antennas installed on joint use poles supporting circuits up to 50 KV and are in accordance with G.O. 95 Rule 94. Antennas and their related crossarms, brackets, hardware, risers, control boxes, etc. shall meet the requirements detailed below.

#### A. Clearances (Also see illustrations in Figure 6 through Figure 10)

- (1) Antennas and supporting elements (e.g. crossarms, brackets) shall maintain a vertical clearance of 6 feet below Supply Conductors operating at 0 – 50kV.
- (2) Antennas and their support elements (e.g. crossarms, brackets) shall maintain a 2 ft. vertical separation from communication conductors and equipment. Antennas may be installed above or below communication conductors as long as the installation complies with the clearance requirements outlined in items (1) and (3) of this section.
- (3) Antennas, associated equipment (e.g. terminations, enclosures) and their support elements installed above supply lines and/or communication lines of different ownership shall maintain vertical clearances as specified in Rule 38 Table 2, Case 21 Columns A–H. These requirements are summarized below.

##### (a) Minimum vertical clearance of antennas and associated support elements from:

- (i) Span wires, guys and messengers – 2 feet
- (ii) Communication conductors – 2 feet
- (iii) 0–750 volt conductors including service drops – 4 feet
- (iv) 750–35,000 volt conductors – 6 feet

##### (b) Notes:

- (i) Vertical runs or risers associated with the antenna(s) may terminate 1 foot below the antenna or support element for conditions (a) (i) or (a) (iii) above.
- (ii) Service drops, that serve only the antenna, may terminate 10 inches below the antenna and its support elements.
- (4) Antennas, associated equipment and support elements, installed above supply or communication lines, shall maintain radial clearances from unattached supply and communication lines as specified in Rule 38, Table 2 Case 3. These requirements are summarized below.

##### (a) Minimum radial clearance of antennas, equipment and associated support elements from:

- (i) Span wires, guys, messengers and communication conductors – 2 feet
- (ii) 0–750 volt conductors including service drops – 4 feet
- (iii) 750–7,500 volt conductors – 4 feet
- (iv) 7,500–20,000 volt conductors – 6 feet
- (v) 20,000 – 150,000 volt conductors – 8 feet
- (vi) Above 150KV see G.O. 95.

- (5) Antennas shall maintain a 2 foot horizontal clearance from centerline of pole when installed between supply and communication lines or below communication lines.
- (6) There is no horizontal clearance from centerline of pole for antennas installed between supply lines or at the top of the pole, but the antenna and support elements must be arranged so that the pole can be safely climbed.
- (7) Antennas shall have a vertical clearance above ground as specified in Table 1, Column B Cases 1 to 6a of G.O. 95. This requires antennas that overhang buildings, walkable surfaces, roadways etc. meet the same vertical clearance requirements as communication conductors.

#### B. Climbing Space must be maintained except for the allowable climbing space obstructions. Reference G.O. 95 Rule 54.7 A (3). Antennas, associated equipment and support elements are not allowed in the climbing space. When antennas are installed above supply lines at the top of the pole, climbing space must be maintained to:

- (1) The bottom of the antenna (including associated support elements) if affixed less than 8 inches from the surface of the pole.

## Installation Details for Service to Pole-Mounted Communication Equipment

- (2) The top of the pole or pole top extension if the antennas are affixed more than 8 inches from the surface of the pole or pole top extension.

Note: Climbing space can be difficult to maintain with antenna installations due to antenna size, number, configuration, and orientation on the pole. In addition, most installations have multiple risers and vertical runs, grounds, equipment and metering enclosures. As always, good communication, up front, is essential to ensure adequate space is available to accommodate the antenna and all the associated equipment.

- (3) Pole Steps: Stepping must be in accordance with Rule 91.3. No pole steps are to be installed in the supply space or above supply lines except for any necessary steps associated with a pole top extension bracket.
  - (4) Risers, grounds and vertical conductor runs on non-metallic structures:
    - (a) Risers, grounds and vertical runs passing supply lines and/or communication lines and/or their associated equipment shall be suitably covered throughout their length, shall be installed outside the climbing space and shall be constructed and maintained in accordance with Rule 54.6-D 1, 2, 3, and 5 (requirements for vertical runs for supply lines).
    - (b) The suitable protective covering (see Rule 22.8) for risers, grounds and vertical runs passing supply lines and/or equipment shall extend no less than:
      - (i) 3 feet above lines energized from 0 – 750 volts
      - (ii) 6 feet above lines energized from 750 – 35,000 volts
      - (iii) 9 feet above lines energized from 35,000 – 50,000 volts
  - (5) Risers, grounds and vertical conductor runs on metallic structures that pass supply lines and/or communication lines and/or equipment shall occur on a single structure and shall be installed outside the climbing space in accordance with Rule 54.6-D4.
- C. Signage: Poles shall be marked with a sign or signs for each antenna installation. The sign shall contain the following information and placement.
- (1) Name / identification of the antenna operator
  - (2) A 24-hour contact number of antenna operator for emergency notification or other information
  - (3) Unique identifier of the antenna installation
  - (4) Indication that the antennas RF output is in compliance with the FCC General Population (G.P.) uncontrolled exposure limits or, if the antenna exceeds those limits indication of the minimum approach distance. See Utility Procedure [TD-2001P-01](#) Procedures for Working Around Antennas for examples of typical RF signage.
  - (5) Located above the SmartPole Meter and not greater than 15 feet above grade.

### D. Disconnect switch

- (1) Antennas that exceed the FCC's General Population (G.P.) Uncontrolled Limits
  - (a) Require the antenna owner to provide a disconnect switch that is readily accessible to PG&E. This switch must de-energize all sources of power to the antenna, both AC and any battery backup.
  - (b) Require the antenna owner to establish a protocol, agreed to by PG&E, for powering down the antenna site.
  - (c) Will be operated by mutual agreement except during emergencies.

Note: Minimum Approach Distances (MADs) must be indicated on the antenna signage.

- (2) Antennas that meet the FCC's General Population (G.P.) Uncontrolled Limits
  - (a) Do not require a disconnect switch for these low power antennas.
  - (b) Require the wireless company to submit documentation indicating the maximum RF output of the antenna meets the FCC requirements for General Population/Uncontrolled RF exposure.

27. Notification of Conditions to Third Party Utility: If an existing antenna installation is found that does not meet the design and construction requirements detailed in 1 thru 7 above, a 3rd party notification (Form -3447) should be created. Typical problems involve antennas, risers or other equipment installed in the climbing space, inadequate clearances or signage, and antennas installed in the Safety Clearance Zone on joint poles. These conditions



### Installation Details for Service to Pole-Mounted Communication Equipment

present a hazard for workers and must be corrected within the timelines described in Utility Standard [TD-2014S](#) Notification of Conditions to Third-Party Utility.  
Also see the, Design and Construction Checklist for Third Party Antennas, for requirements and typical deficiencies.

#### 28. Design and Construction Requirements for Antennas and Other Equipment on Streetlight Poles

##### A. Antennas and other equipment on PG&E-owned streetlight poles

- (1) PG&E will not sell ownership interest in a streetlight-only pole. Third party attachments, antennas or other equipment (see note below) may be permitted under a license agreement. Requests from a NCJPA Member to become a joint pole owner (for streetlight only poles), via Form 2, should be rejected. Refer all requests to PG&E's NRD Department.
- (2) Licensing for third party antennas, gunshot detectors, government owned cameras, and other equipment will be managed by PG&E's NRD Department. Consult with NRD and Electric Distribution Standards for the applicable design, construction and other requirements.
- (3) Where applicable, unmetered attachments to streetlights must also meet the requirements outlined in Form 79-1078 – Agreement for unmetered electric service to devices connected to Pacific Gas and Electric Company's streetlight facilities.
- (4) Antennas are not allowed on poles with decorative, semi-decorative, or "Special facility" streetlights that the customer has chosen from our appliance product mix or outside of the normal product mix. Exceptions may be allowed when the streetlight customer of record states, in writing, that they have no objection to the installation. Refer any requests to PG&E's New Revenue Development (NRD) Department.

#### 29. Antennas on customer owned streetlight poles.

A. Antenna projects involving customer owned streetlight poles will be managed by PG&E's. Streetlight Program Manager. Streetlight poles installed under the following rate schedules are not owned by PG&E therefore any requests for attachment should be directed to the pole owner.

- (1) LS-1C, Customer owns pole and foundation
- (2) LS-2A, B, and C
- (3) OL-1

B. Where the requesting party wants to attach to a PG&E owned streetlight mast arm on a customer owned pole, a letter of approval must be acquired by the requesting party from the PG&E customer receiving lighting service.

C. A separate energy connection for the antenna must be made under the governing tariff in absence of any special CPUC approved agreement. The 79-1048 agreement (and Rate Schedule LS-2) allows antennas on city owned streetlight poles to utilize the streetlight photo control receptacle as the energy source where the installation meets the loading limitation and all other requirements of the agreement.

**Table 1 Bill of Material to Be Furnished by the Communication Company**

Item	Description
1	Conduit, Rigid, PVC, Schedule 80 <sup>1</sup> (size as required)
2	Pipe Straps, Galvanized
3	Conduit Fittings (as required)
4	Wire, 600 V, Size as Required
5	Service Weather Head, PVC
6	SmartPole Meter Enclosure <a href="#">094675</a> , as required
7	Steps, Pole (if pole is unstepped)

<sup>1</sup> Use Schedule 80 for 1-1/2" or smaller, or Schedule 40 for 2".

**Installation Details for Service to Pole-Mounted Communication Equipment****Table 2 Bill of Material to Be Furnished and Installed by PG&E**

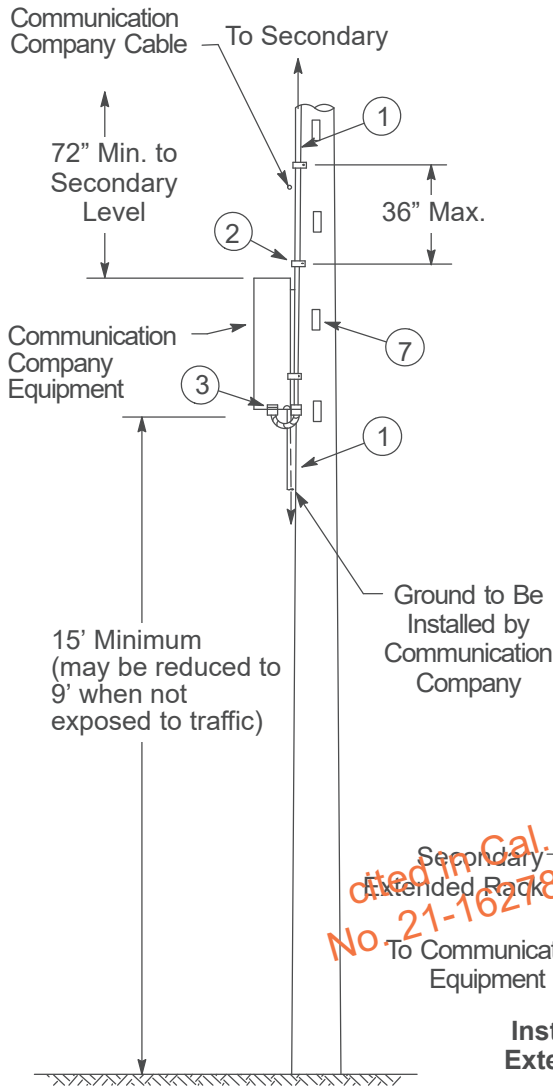
Item	Description	Code	Document
8	Connector, Compression or Wedge (as required)	-	<a href="#">041010</a>
9	Conduit, Rigid, PVC, 2"	360234	<a href="#">021924</a>
10	SmartPole Meter, Watthour (as required)	-	-

**Note**

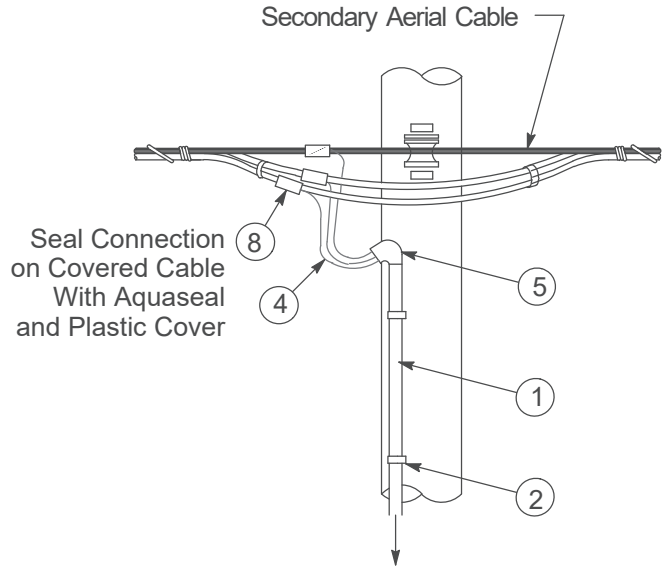
1. Unmetered load may be 2-wire, 120 V or 3-wire, 120/240 V.
2. When a SmartPole Meter is required refer to TD-027911B-002 SmartPole Meter for Service to Pole-Mounted Communication Equipment.

*cited in Cal. Rest. Ass'n v. City of Berkeley  
No. 21-16278am archived December 27, 2023*

### Installation Details for Service to Pole-Mounted Communication Equipment

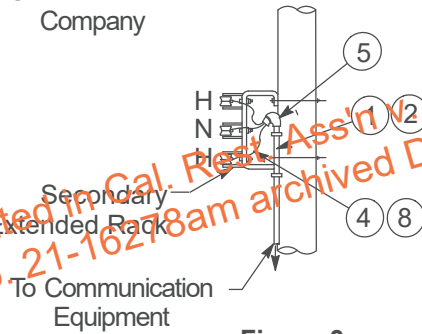


**Figure 1**  
Unmetered Service Connection  
to Communication Equipment



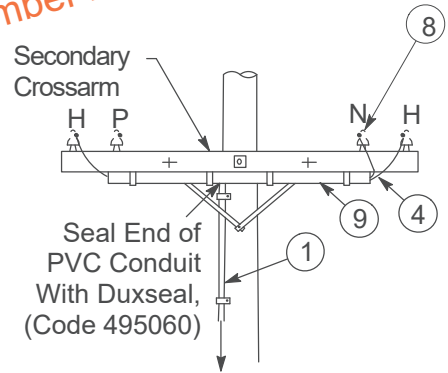
**Figure 2**  
Installation With Aerial  
Cable Secondary

*Noted in Cal. Reg. Ass'n v. City of Berkeley  
No. 21-16278am archived December 27, 2023*



**Figure 3**  
Installation With Existing  
Extended Rack Secondary

**Note: New Extended Rack  
Construction is not allowed**

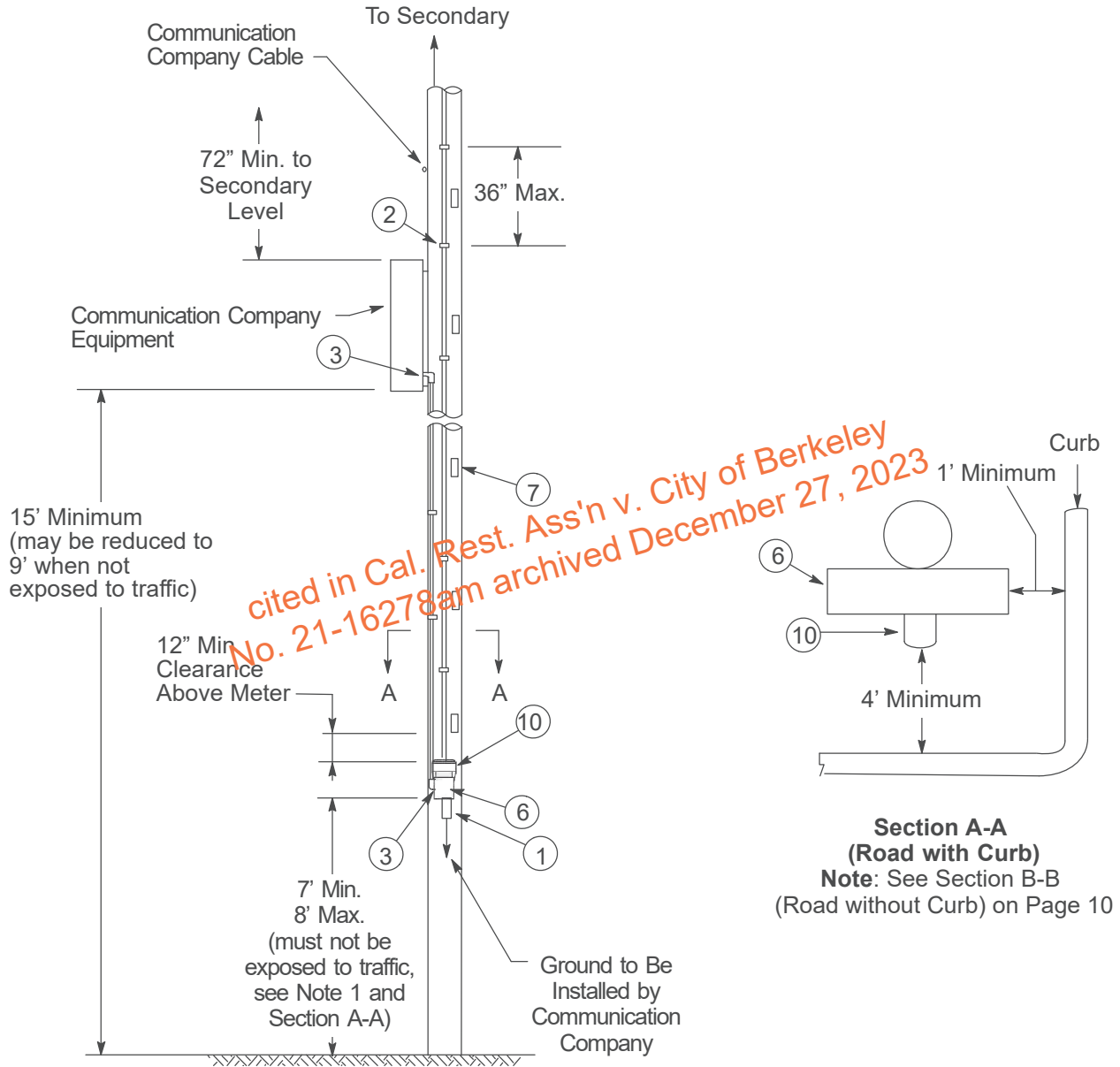


**Figure 4**  
Installation With Crossarm  
Secondary

## Installation Details for Service to Pole-Mounted Communication Equipment

### Notes

1. For poles close to curbs avoid exposure to equipment and personnel. It is best to place the meter on a side of the pole away from traffic. If this cannot be done, the following conditions must be met:
  - A. The meter must be no closer than 4 feet to a curb to provide safe access and reading.
  - B. If the meter panel extends to the side past the pole, it cannot be closer than 1 foot to a curb.
  - C. For meters on poles next to driveways or roads without curbs see Section B-B (Driveway or Road without Curb) and associated notes on Page 9 .



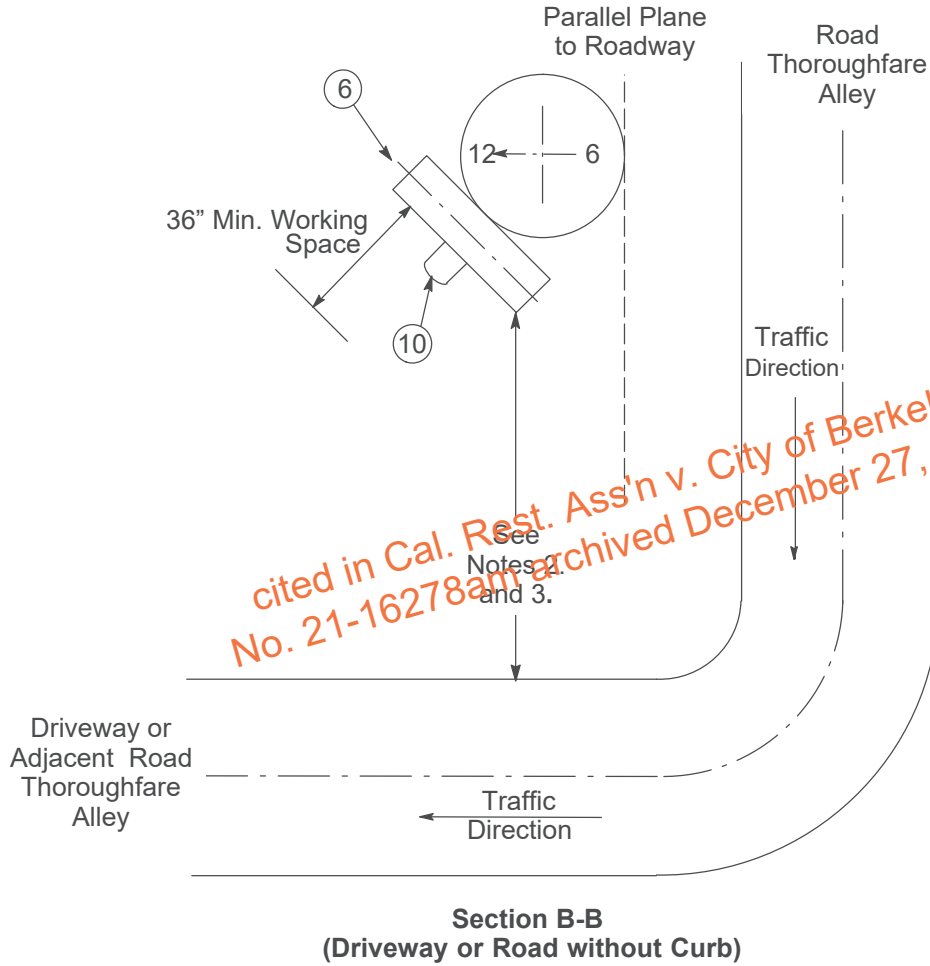
**Figure 5**  
**Pole-Metered Service Connection to**  
**Communication Equipment**

### Installation Details for Service to Pole-Mounted Communication Equipment

#### Notes

For poles next to roads that have no curb, rolled curbs, sidewalk or curb ramps, driveways, including the driveway apron (approach), or other type of non-curbed vehicle entrance, avoid exposure to equipment and personnel by placing the meter panel on the back side of the pole away from the road or vehicle entrances. The meter panel can only be placed in the 12 O'clock position, between the 9 to 12 O'clock position, or between the 12 to 2 O'clock positions. The meter panel must not,

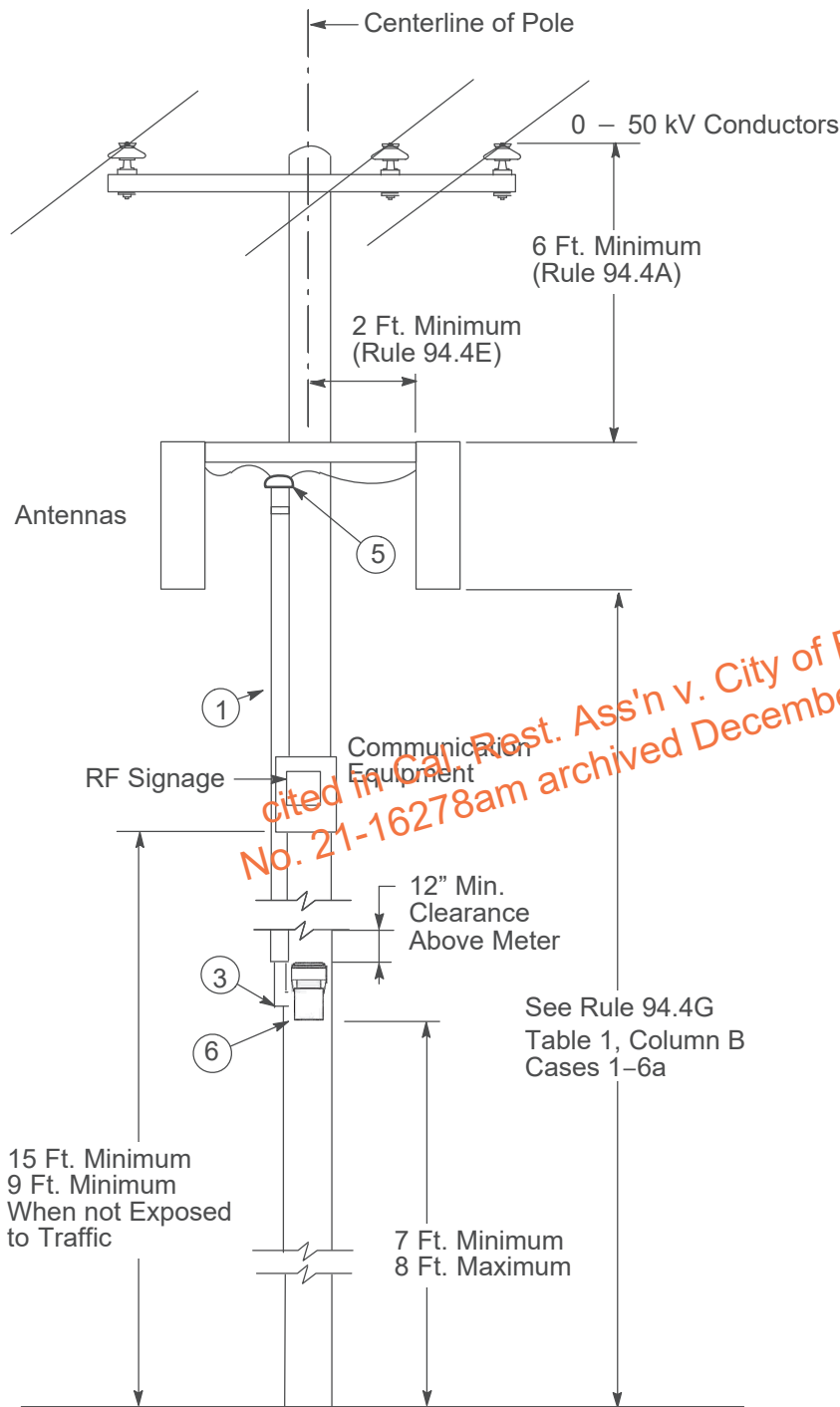
1. Extend out past the parallel plane of the pole to the roadway.
2. Be closer than 8 feet (96 inches) from adjacent roads or non-residential driveways.
3. Be closer than 4 feet (48 inches) from residential driveways or sidewalk ramps.



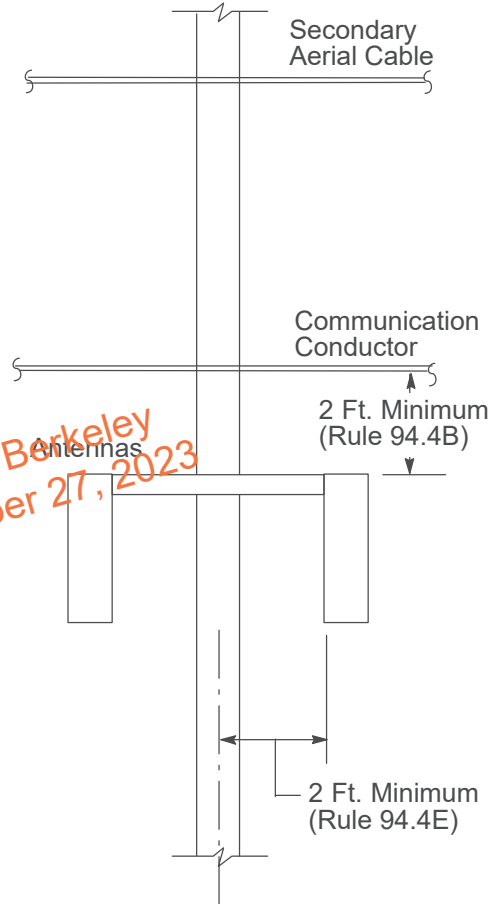
### Installation Details for Service to Pole-Mounted Communication Equipment

**Notes**

1. Consideration should be given on reserving additional space (> 6 Ft.) for proposed or future installation of PG&E wires and equipment.



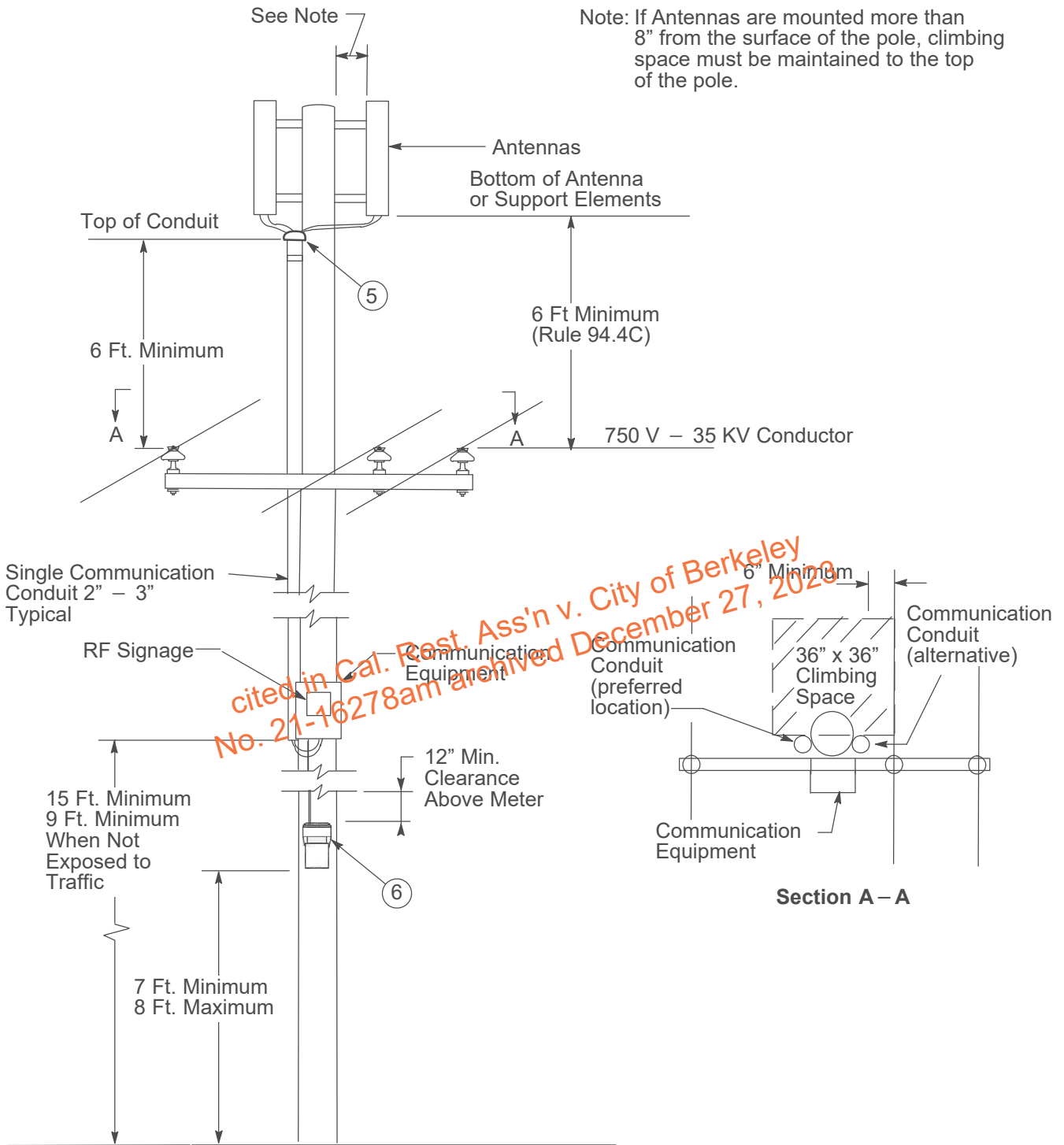
**Figure 6**  
**Antenna - Below Supply Lines**



**Figure 7**  
**Antenna - Below**  
**Communication Lines**

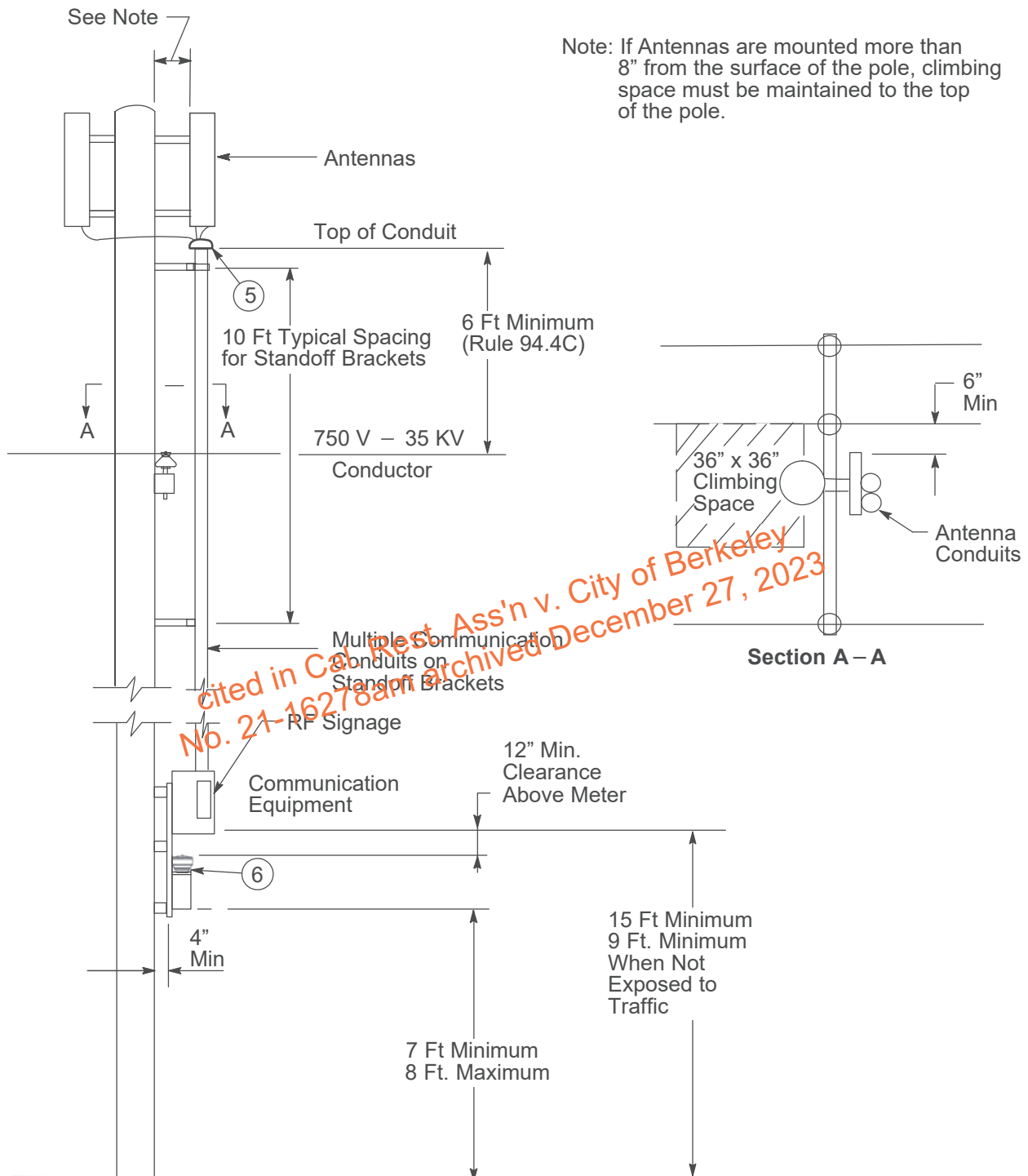
*cited in Cal. Post. Ass'n v. City of Berkeley  
No. 21-16278am archived December 27, 2023*

### Installation Details for Service to Pole-Mounted Communication Equipment



**Figure 8**  
**Pole Top Antenna - Single**  
**Communication Conduit Run**

**Installation Details for Service to Pole-Mounted Communication Equipment**

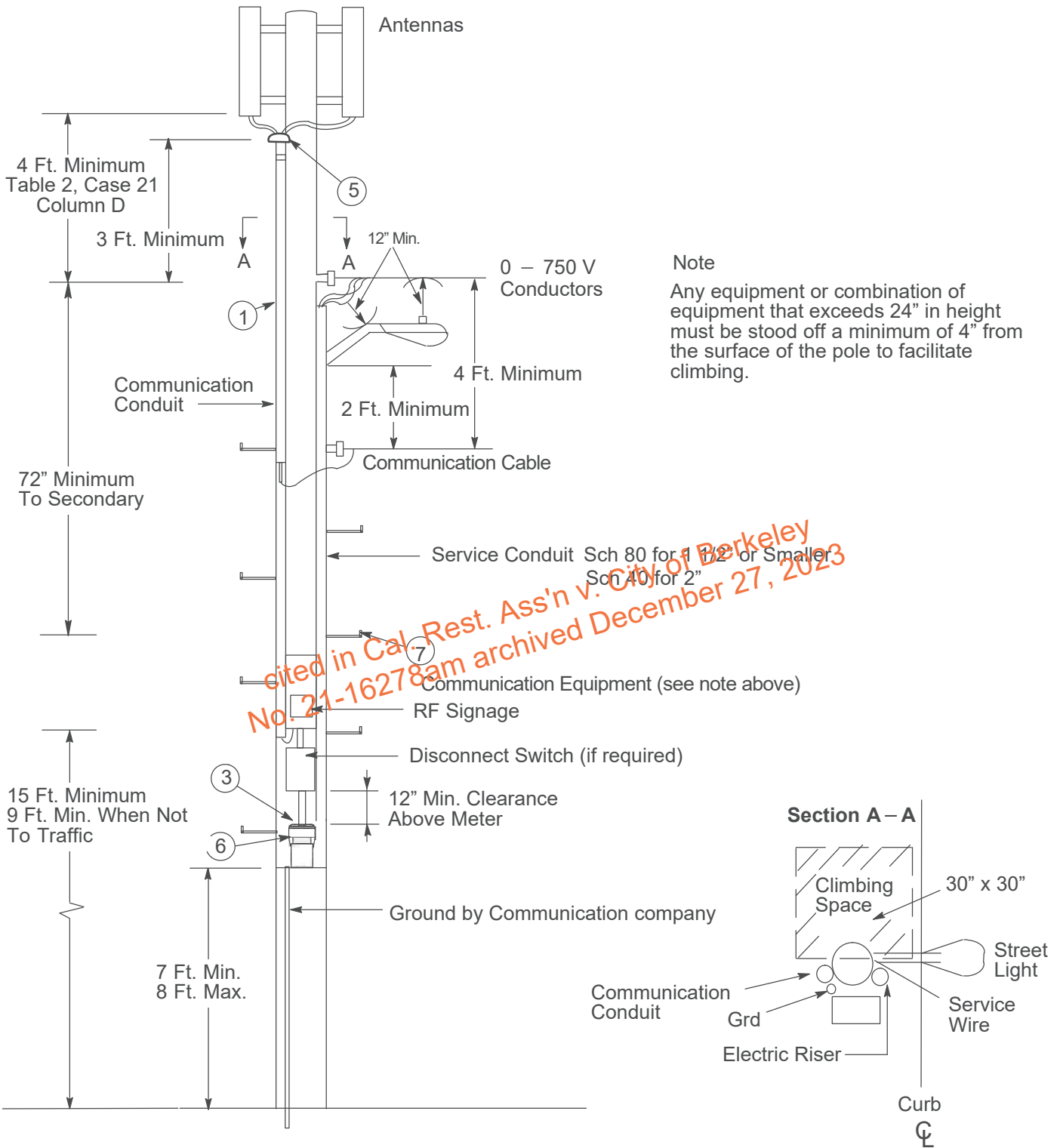


*cited in Cal. Rest. Ass'n v. City of Berkeley  
No. 21-16278 am. Archived December 27, 2023*

**Figure 9  
Pole Top Antenna - Multiple Communication  
Conduits on Standoff Brackets**



### Installation Details for Service to Pole-Mounted Communication Equipment



*cited in Cal. Rest. Ass'n v. City of Berkeley  
No. 21-16278am archived December 27, 2023*

**Figure 10**  
**Pole Top Antenna - Streetlight Only Poles**

## Installation Details for Service to Pole-Mounted Communication Equipment

---


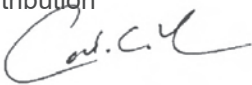
### Revision Notes

Revision 14 has the following changes:

1. Updated the Purpose and Scope on Page 1.
2. Edited Note 2 on Page 1.
3. Edited Note 6 on Page 1.
4. Separated Note 8 into four. Notes 8 through 12.
5. Added new new Notes 15.C. and 15.D.
6. Created new Notes 20, 21, 22, 23 and 24 on Page 3.
7. Updated Reference Section on Page 3.
8. Updated references in Table 1 on Page 6.

*cited in Cal. Rest. Ass'n v. City of Berkeley  
No. 21-16278am archived December 27, 2023*

cited in Cal. Rest. Ass'n v. City of Berkeley  
No. 21-16278am archived December 27, 2023

	<b>SECONDARY ELECTRIC UNDERGROUND ENCLOSURES</b>	<b>028028</b>
<b>Asset Type:</b> Gas and Electric Distribution		<b>Function:</b> Design and Construction
<b>Issued by:</b> Calvin Yu (CCY6) 		<b>Date:</b> 03-25-22
<b>Rev. #22:</b> This document replaces PG&E Document 028028, Rev. #21. For a description of the changes, see Page 14.		

**This document is also included in the following manual:**

- [Electric and Gas Service Requirements Manual](#) (Greenbook)

**Purpose and Scope**

This document provides specifications, ordering information, illustrations, and application instructions for the various sizes of non-concrete and precast concrete enclosures used in PG&E electric underground secondary distribution.

**General Information**

- The words boxes/enclosures have the same meaning and are used interchangeably.
- The design loads for these subsurface enclosures are specified in [Engineering Material Specification No. 51, "Non-Concrete Enclosures"](#), and in [Engineering Material Specification No. 53, "Electric Underground Concrete Enclosures"](#)
- Requirements for non-concrete, non-deliberate vehicular traffic enclosures and covers:
  - Non-concrete enclosures for incidental loading must meet the requirements of [Engineering Material Specification No. 51, "Non-Concrete Enclosures"](#).
  - The cover and exposed portions of a enclosure shall be of a concrete color. Enclosures may not be painted other colors.
  - Enclosures shall comply with this document concerning marking, security devices, and dimensions.
  - Enclosure covers must have PG&E identification. The enclosure body and cover must be labeled with the manufacturer's name, enclosure weight, and have the PG&E code number on inside surfaces.
  - The cover shall be made of polymer concrete and shall have a PG&E-approved high coefficient of friction (0.65 or better), slip-resistant surface.
  - Non-concrete parts shall be interchangeable.
- Requirements for concrete enclosures, required when installing a secondary enclosure in an area subject to vehicular traffic.
  - Concrete enclosures for full-traffic must meet the requirements of the latest [ASTM C-857](#).
  - Enclosures shall also comply with this document's requirements, such as marking, security devices, and dimensions.
  - Concrete parts shall be interchangeable. Concrete joints shall be interchangeable with those shown in Figure 7 on Page 9, Figure 9 on Page 11, and Figure 11 on Page 13.
  - Covers shall have a PG&E-approved high coefficient of friction (0.65 or better), slip-resistant surface.
  - Enclosure covers must have PG&E identification. The enclosure body, cover, and extension must be labeled with the manufacturer's name, enclosure weight, and have the PG&E code number on inside surfaces.
- Pedestals are no longer allowed for new construction. Replacement pedestal codes can be found in Table 19 of [Document 066205](#).

## Secondary Electric Underground Enclosures

### Application

6. Consider the following when selecting enclosure sizes:
  - A. Secondary non-concrete enclosures are the preferred method of terminating 600 V conductors in residential, small commercial applications and in areas where heavy, non-deliberate vehicular traffic is expected. Concrete secondary enclosures should be installed in areas where full-vehicular traffic is expected.
  - B. Ultimate required conductor size and number to serve the maximum service panel.
  - C. Location of duct entrances, cable layout, and minimum bending radius of cables.
7. The 26" deep enclosures are required for installations of conductors larger than 4/0.
8. When installing any secondary enclosure smaller than 36" x 60", adjust the enclosure to the anticipated natural grade. Install enclosures as level as practical. Do not exceed 2" per foot in any direction. If the maximum grade of 2" per foot cannot be met, the enclosure must be installed level and a retaining wall installed. Use grout or foam placed from the outside to seal around any side entering conduits if side entering conduits are required. Do not pave over the enclosure cover.
9. When installing a 36" x 60" secondary enclosure, install the enclosure as level as practical, but do not exceed 1/8" per foot in any direction. Use adjustment bolts in cover to adjust cover to meet needed final grade. Do not pave over enclosure.
10. Secondary enclosures shall not be used for primary cable.
11. Swedge reducers are necessary with conduit smaller than the terminators supplied (see [Document 062288](#)).
12. All conduits are to be stubbed 1-1/2" min. – 2-1/2" max. from ground level inside the subsurface enclosure. See Figure 5 on Page 7. End bells are required.
13. For new construction, conduit entry shall be as shown in Figure 5 and Figure 6 on Page 7 for splice boxes. Group conduits at one end of the box to achieve maximum cable length to avoid exceeding minimum cable bending radius.
14. For new construction, conduit entry into the #2 and #3 concrete enclosures shall also be as shown in Figure 5 and Figure 6 on Page 7.
15. When replacing an existing box or installing new conduits into an existing box, the conduits may only enter the knockouts or duct terminators when having 18" – 24" of cover at the entrance of the box. A minimum of 18" of conduit entering the side wall must be straight with no bends.
16. Conduits that do not terminate in a duct terminator must be fitted with an end bell.
17. Enclosures shall be set on a 6-inch thick layer of 1" drain rock, mechanically compacted, or alternatively secondary enclosures other than #5 secondary concrete enclosure may be set on a 6-inch thick layer of 3/4" Class 2 Aggregate Base (AB).
18. See [Document 066205](#) for replacement parts for older style installations.

### References

References	Location	Document
<a href="#">Connectors for Insulated Cables Underground</a>		
<a href="#">Distribution Systems</a> .....	<a href="#">UG-1: Connectors/Greenbook</a> .....	<a href="#">015251</a>
<a href="#">Multi-Tap Splice for 600-Volt Insulated Cables</a> .....	<a href="#">UG-1: Splices</a> .....	<a href="#">036640</a>
<a href="#">Straight and Tap Splice for 600 Volt Insulated Cable</a> ..	<a href="#">UG-1: Splices</a> .....	<a href="#">051034</a>
<a href="#">Identification Plates for Subsurface Enclosures</a> .....	<a href="#">UG-1: Marking</a> .....	<a href="#">051768</a>
<a href="#">Primary Electric Underground Equipment Enclosures</a> ..	<a href="#">UG-1: Enclosures/Greenbook</a> .....	<a href="#">062000</a>
<a href="#">Underground Conduits</a> .....	<a href="#">UG-1: Conduits/Greenbook</a> .....	<a href="#">062288</a>
<a href="#">Enclosure Repair/Replacement Criteria and</a>		
<a href="#">Replacement Materials</a> .....	<a href="#">UG-1: Enclosures</a> .....	<a href="#">066205</a>
<a href="#">PG&amp;E Approved Manufacturers</a> .....	<a href="#">Greenbook</a> .....	<a href="#">066211</a>
<a href="#">Engineering Material Specification No. 51.</a>		
<a href="#">"Non-Concrete Enclosures"</a> .....	<a href="#">TIL</a> .....	<a href="#">EMS51</a>
<a href="#">Engineering Material Specification No. 53.</a>		
<a href="#">"Electric Underground Concrete Enclosures"</a> .....	<a href="#">TIL</a> .....	<a href="#">EMS53</a>

## Secondary Electric Underground Enclosures

**Table 1 Guide for Application of Splice Boxes in New Construction for Underground Secondary Using Multi-Tap Splices (see [Document 036640](#))<sup>1</sup>**

Description	-	Enclosure Size				
		11-1/2"	13" x 24"	17" x 30"	24" x 36"	36"x60" <sup>2</sup>
4 Terminal	#6 Str. - 350kcmil	For Streetlight Applications Only (see Note 2 on Page 5)	For Service Runs and Non-Bus Bar Splices (4/0 max)	x <sup>3</sup>	-	-
6 Terminal	#6 Str. - 350 kcmil			x <sup>3</sup>	-	-
8 Terminal	#6 Str. - 350 kcmil			-	x <sup>3</sup>	-
4 Terminal	4/0 - 1,000 kcmil			-	x <sup>3,4</sup>	x
6 Terminal	4/0 - 1,000 kcmil			-	x <sup>3,4</sup>	x
6 Terminal	(4) #6 - 350, (2) 4/0 - 1,000 kcmil			-	x <sup>3,4</sup>	x
8 Terminal	(4) #6 - 350, (4) 4/0 - 1,000 kcmil			-	x <sup>3,4</sup>	x
8 Terminal (one-way configuration)	4/0 - 1,000 kcmil			-	-	x
8 Terminal (two-way configuration)				-	-	x
16 Terminal (two-way configuration)				-	-	x

<sup>1</sup> For approved suppliers, see [Document 066211](#).

<sup>2</sup> If using splices, 36" x 60" enclosure can accommodate up to 14 runs (7 in and 7 out or combination) of 1,000 kcmil or smaller wires.

<sup>3</sup> 350 kcmil and larger conductor installations require a 26-inch deep non-concrete enclosure or a 12-inch extension with a concrete enclosure.

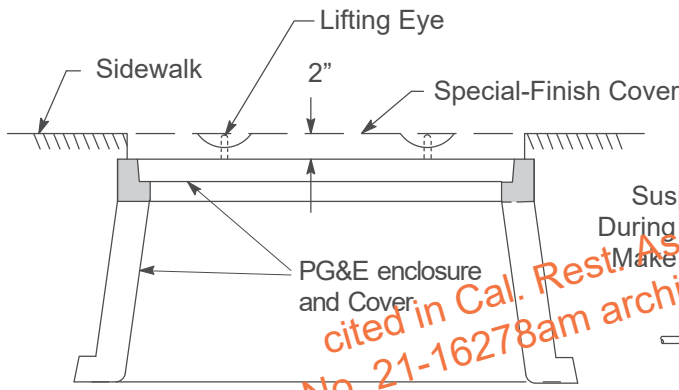
<sup>4</sup> The maximum number of runs of 750 kcmil and 1,000 kcmil conductors will be limited to a total of 2 runs (1 in and 1 out) not including or limiting other smaller conductors in the enclosure; otherwise a 36" x 60" enclosure is needed.

### Secondary Electric Underground Enclosures

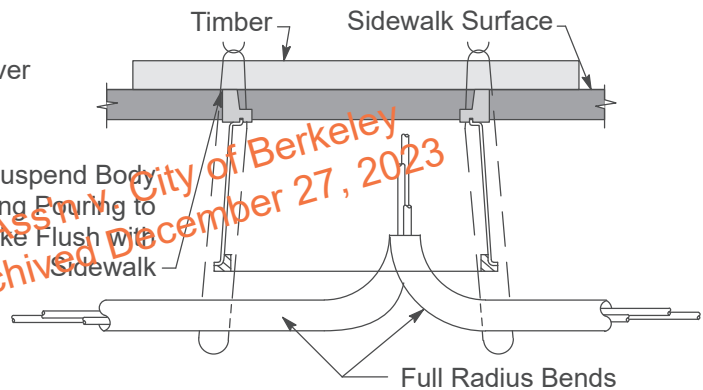
#### Installation of Enclosures in Special-Finish Sidewalks

##### Notes

1. Frequently the customer or city (or other public entity) installs special-finish sidewalks (brick, tile, terrazzo, etc.). When required with enclosures through 3' x 5', the enclosure and standard cover shall be installed 2-inch below the final grade, and the customer or city shall furnish and install the special-finish cover as illustrated in Figure 1 on Page 4
2. The requirements for this cover shall be as follows:
  - A. No single section of cover shall exceed 125 pounds.
  - B. Provisions for removal shall be provided.
  - C. The special-finish cover shall be identified by the letter "E" to indicate the location of the PG&E splice enclosure.
  - D. This type of enclosure shall not be installed in locations where vehicular traffic is expected.
  - E. **Caution:** PG&E cover design allows for a maximum of 1/2-inch deflection under an 8,000-pound or 12,000-pound design load, depending on the specified cover.



**Figure 1**  
Installation of Enclosures in  
Special-Finish Sidewalks



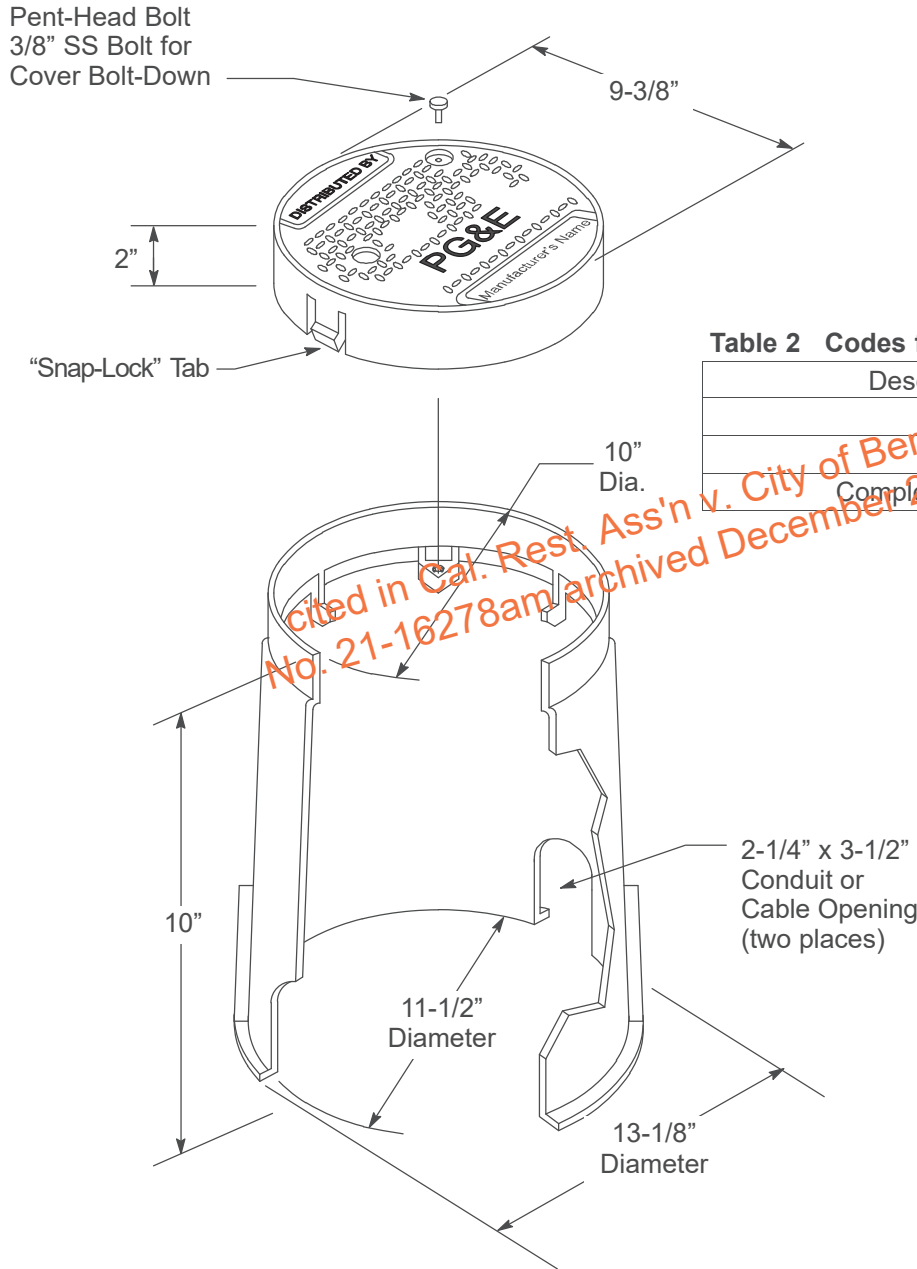
**Figure 2**  
Installation of Non-Concrete Enclosures  
in Sidewalks

**Secondary Electric Underground Enclosures**

**Streetlight Enclosure Assembly**

**Notes**

1. In conduit systems, enter the bottom of the box with 90° sweeps.
2. Do not connect more than two streetlights per enclosure.
3. Three is the maximum number of conduits allowed.
4. For streetlight applications only (see Table 1 on Page 3).



**Table 2 Codes for Streetlight Box Components**

Description	Code
Cover	032509
Body	032510
Complete Assembly	032511

**Figure 3  
Streetlight  
Enclosure**



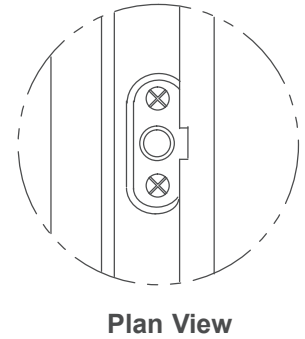
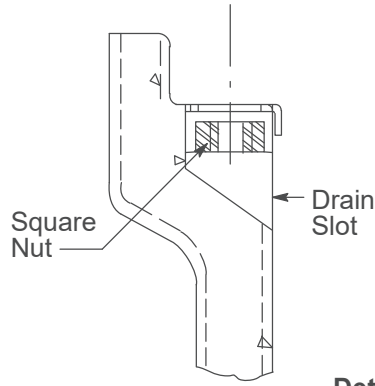
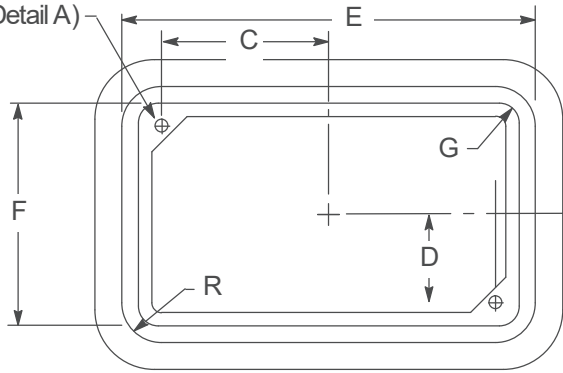
### Secondary Electric Underground Enclosures

#### Non-Concrete Enclosure for Incidental Traffic

##### Note

1. See Table 3 on Page 7 and Table 4 on Page 8 for box dimensions.

Bolt-Down Feature, Pent-Head, Coil Thread,  
1/2" x Length as Required, 1/2" Nut, Two Locations  
(see Detail A)

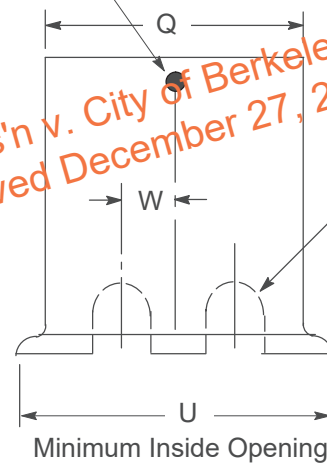
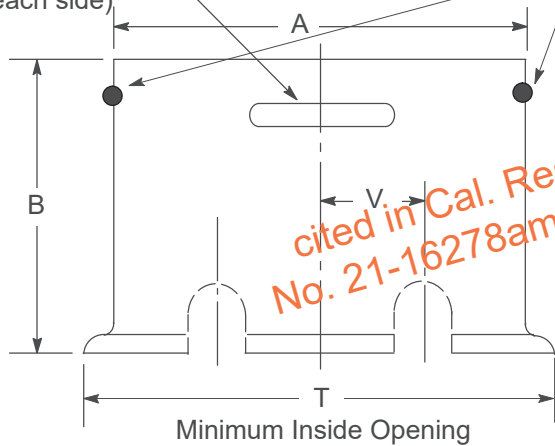


Detail A

Concrete Key (1-1/2" x 15")  
(one each side)

Thru Holes for Lifting Eye Bolts

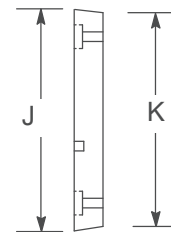
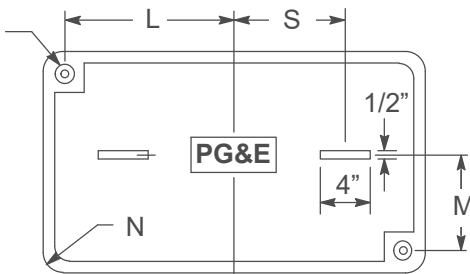
(two lifting eye bolts on the  
13" x 24" box,  
17" x 30" box and four  
on the 24" x 36" box)



*cited in Cal. Rest. Ass'n v. City of Berkeley  
No. 21-16278am archived December 27, 2023*

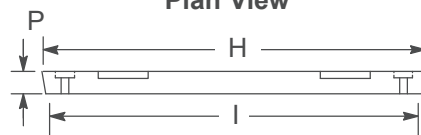
Single Knockout on  
13" x 24" x 26" Box  
4-3/4" x 4-3/4"

Hole for 1/2" Bolt With  
Recess for Head  
(see Detail A)



Plan View

End View



Side View

Figure 4  
Cover

Secondary Electric Underground Enclosures

Non-Concrete Enclosures for Incidental Traffic (continued)

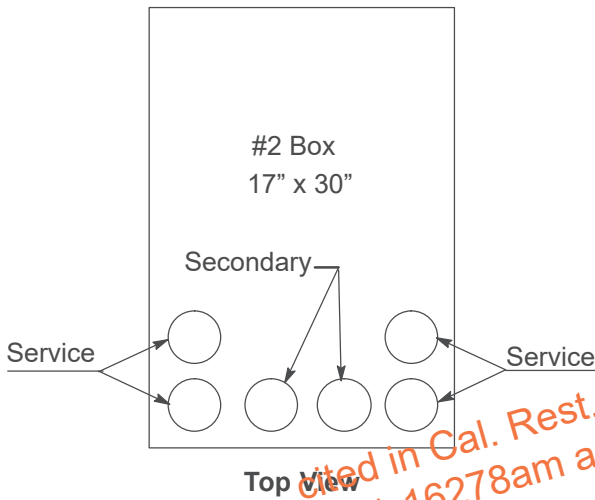
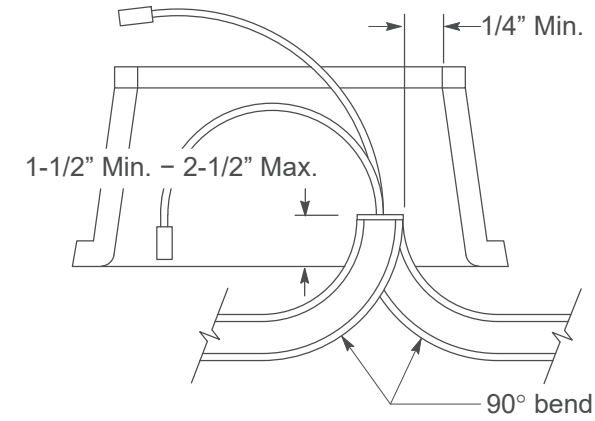


Figure 5  
Location of Conduits Entering 17" x 30" Splice Box

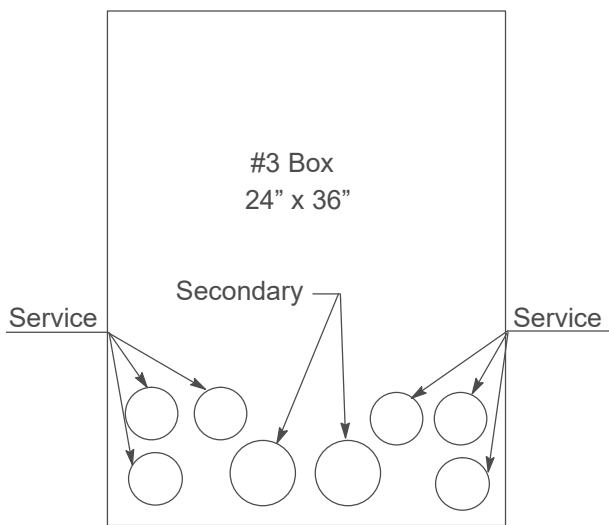


Figure 6  
Location of Conduits Entering 24" x 36" Splice Box

Table 3 Codes for Enclosure Components and Assemblies

Enclosure		Description	Code	
Size (inches)	Depth (inches)			
13 x 24	18	Body	040931	
	18	Assembly <sup>1</sup>	040933	
	26	Body	040920	
	26	Assembly <sup>1</sup>	040935	
	8,000 lb Cover			043716
	-			-
17 x 30 <sup>2</sup>	18	Body	040928	
	18	Assembly <sup>1</sup>	040936	
	26	Body	040929	
	26	Assembly <sup>1</sup>	040937	
	8,000 lb Cover			043720
	-			-
24 x 36	18	Body	040930	
	18	Assembly <sup>1</sup>	040940	
	26	Body	040919	
	26	Assembly <sup>1</sup>	040942	
	8,000 lb Cover			043724
	-			-
All	Pent-Head Bolt Coil Thread 1/2" x	2-1/2"	192853	
		3-1/2"	017488	
		4-1/2"	017489	

<sup>1</sup> Includes cover and body.  
<sup>2</sup> Only six conduits allowed in 17" x 30" boxes.

## Secondary Electric Underground Enclosures

**Non-Concrete Enclosures for Incidental Traffic (continued)****Table 4 Dimensions of Non-Concrete Enclosures**

Enclosure Size (inches)	Dimensions (inches)									
	A	B	C	D	E	F	G	H	I	J
13 x 24 x 18	25-1/4	18	9-7/8	5-1/8	23-1/2	14	1-1/2	-	-	-
-	-	-	-	-	-	-	-	-	-	-
13 x 24 x 26	25-1/4	26	-	-	29-1/4	19-3/4	-	-	-	-
13 x 24 Cover	-	-	-	-	-	-	-	23-1/4	23	13-3/4
17 x 30 x 18	32-1/2	18	13-1/4	6-3/4	30-3/4	17-3/4	1-1/2	-	-	-
-	-	-	-	-	-	-	-	-	-	-
17 x 30 x 26	32-1/2	26	-	-	30-3/4	17-3/4	-	-	-	-
17 x 30 Cover	-	-	-	-	-	-	-	30-1/2	30-1/4	17-1/2
24 x 36 x 18	37-7/8	18	15-9/16	9-3/4	35-7/8	24-1/4	5-1/8	-	-	-
-	-	-	-	-	-	-	-	-	-	-
24 x 36 x 26	37-7/8	26	15-9/16	9-3/4	35-7/8	24-1/4	5-1/8	-	-	-
24 x 36 Cover	-	-	-	-	-	-	-	35-5/8	35-1/8	24
Enclosure Size (inches)	Dimensions (inches)									
	K	L	M	N	P	Q	R	S	T	U
13 x 24 x 18	-	-	-	-	-	15-3/4	4-5/8	-	24-7/8	15-3/8
-	-	-	-	-	-	-	-	-	-	-
13 x 24 x 26	-	-	-	-	-	15-3/4	4-1/2	-	25-3/16	15-5/8
13 x 24 Cover	13-1/2	9-7/8	5-1/8	1-3/8	2	-	-	8	-	-
17 x 30 x 18	-	-	-	-	-	19-1/2	4-5/8	-	32-1/8	19-1/8
-	-	-	-	-	-	-	-	-	-	-
17 x 30 x 26	-	-	-	-	-	19-1/2	4-1/2	-	32-3/8	19-3/8
17 x 30 Cover	17-1/4	13-1/4	6-3/4	1-3/8	2	-	-	9	-	-
24 x 36 x 18	-	-	-	-	-	26	6	-	37-1/4	25-5/8
-	-	-	-	-	-	-	-	-	-	-
24 x 36 x 26	-	-	-	-	-	26	6	-	37-9/16	25-15/16
24 x 36 Cover	23-1/2	15-9/16	9-3/4	5	3	-	-	11	-	-

**Table 5 Knockout Dimensions from Center of Wall of Non-Concrete Enclosures**

Enclosure Size <sup>1</sup>	Dimensions (inches)		Number of Knockouts
	V	W	
13" x 24" x 26"	7-1/2	0	6
17" x 30" x 26"	10-1/2	5	8
24" x 36" x 26"	11	5-1/2	8

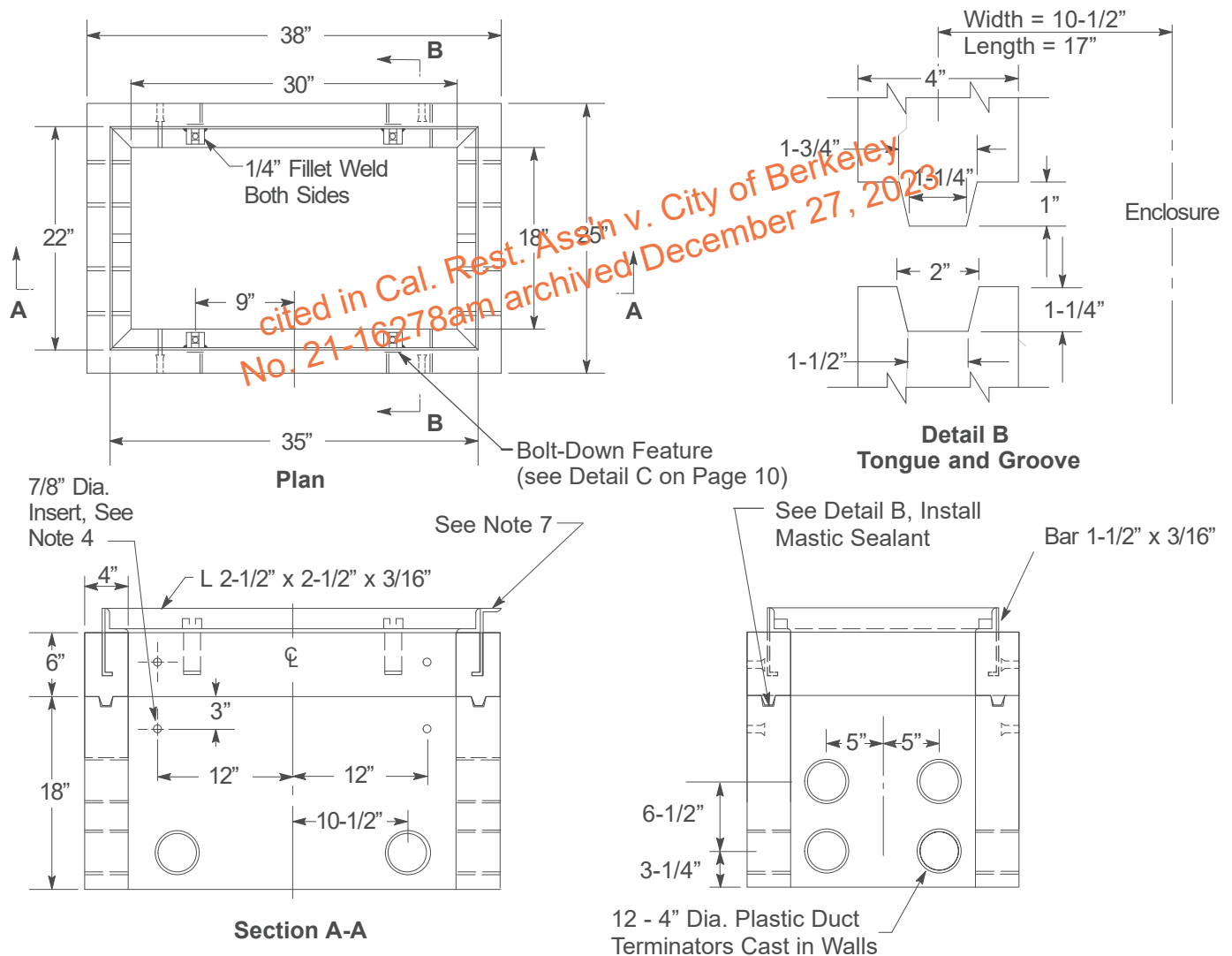
<sup>1</sup> Knockouts in 26" deep enclosures only.

### Secondary Electric Underground Enclosures

#### 17" x 30" (#2) Concrete Enclosures for Full-Vehicular Traffic

**Notes**

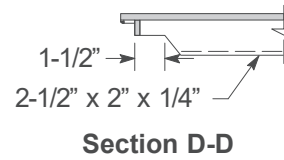
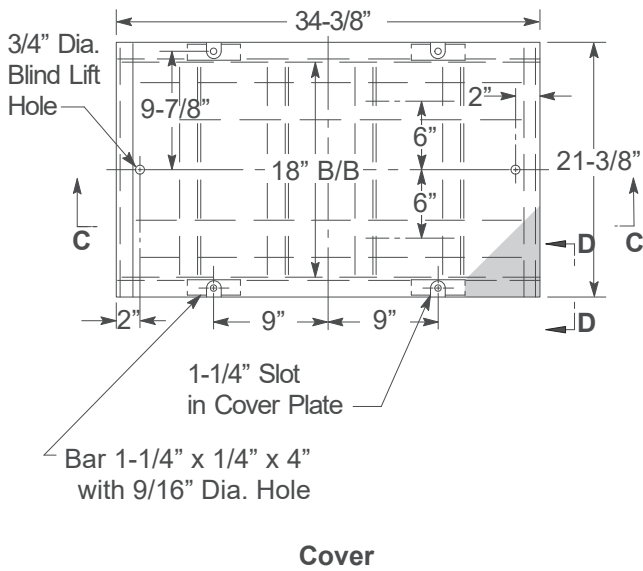
1. Grade adjustment, when required, shall be made between the box and the extension or top section.
2. A base is not required.
3. All concrete parts shall be permanently identified as to the manufacturer on the inside surface. The weight shall be stenciled on the outside of all concrete parts.
4. All concrete parts shall be provided with four 7/8-inch diameter, 1-3/4-inch minimum deep inserts with UNC Class 2A threads.
5. Joints must be interchangeable with those shown in Detail B.
6. Install mastic sealant provided with enclosure assembly for all concrete-to-concrete joints below surface level.
7. The identification plate is an integral part of the cover and should be included by the manufacturer.
8. For new construction conduits shall enter the enclosure using 90 degree elbows rising into the enclosure. Refer to Figure 5 and Figure 6 on Page 7.



**Figure 7**  
Concrete Enclosure

### Secondary Electric Underground Enclosures

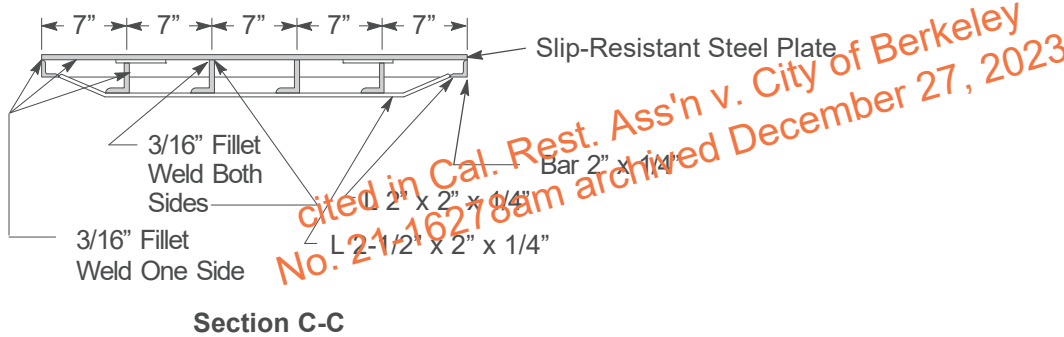
#### 17" x 30" (#2) Concrete Boxes for Full-Vehicular Traffic (continued)



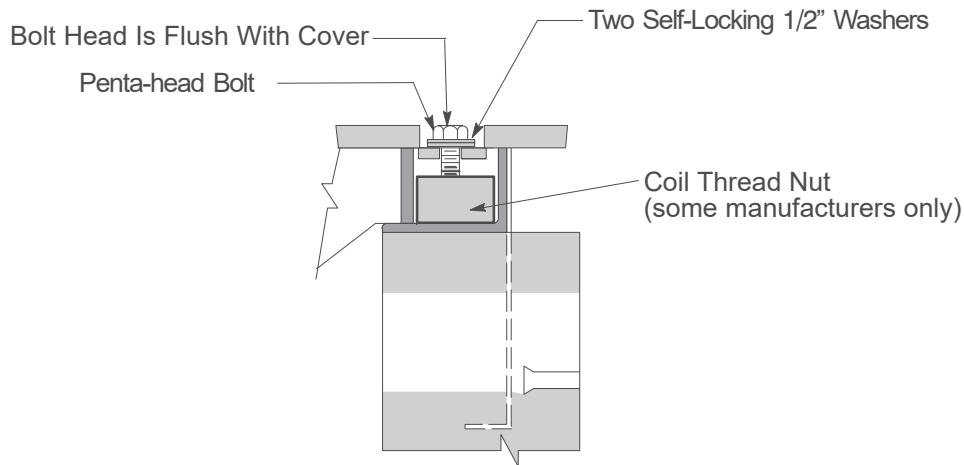
**Table 6 Codes for Complete 17" x 30" Concrete Box Assemblies**

Box		Code <sup>1</sup>
Type	Depth	
Full-Vehicular-Traffic With Slip-Resistant Cover	24"	019588
	30"	019597
Extension	6"	043517

<sup>1</sup> PG&E assembly code includes body with a 6" or 12" top section with cast-in frame and a cover. If more depth is required, order the 6" extension.



**Section C-C**



**Detail C Bolt-Down Feature**

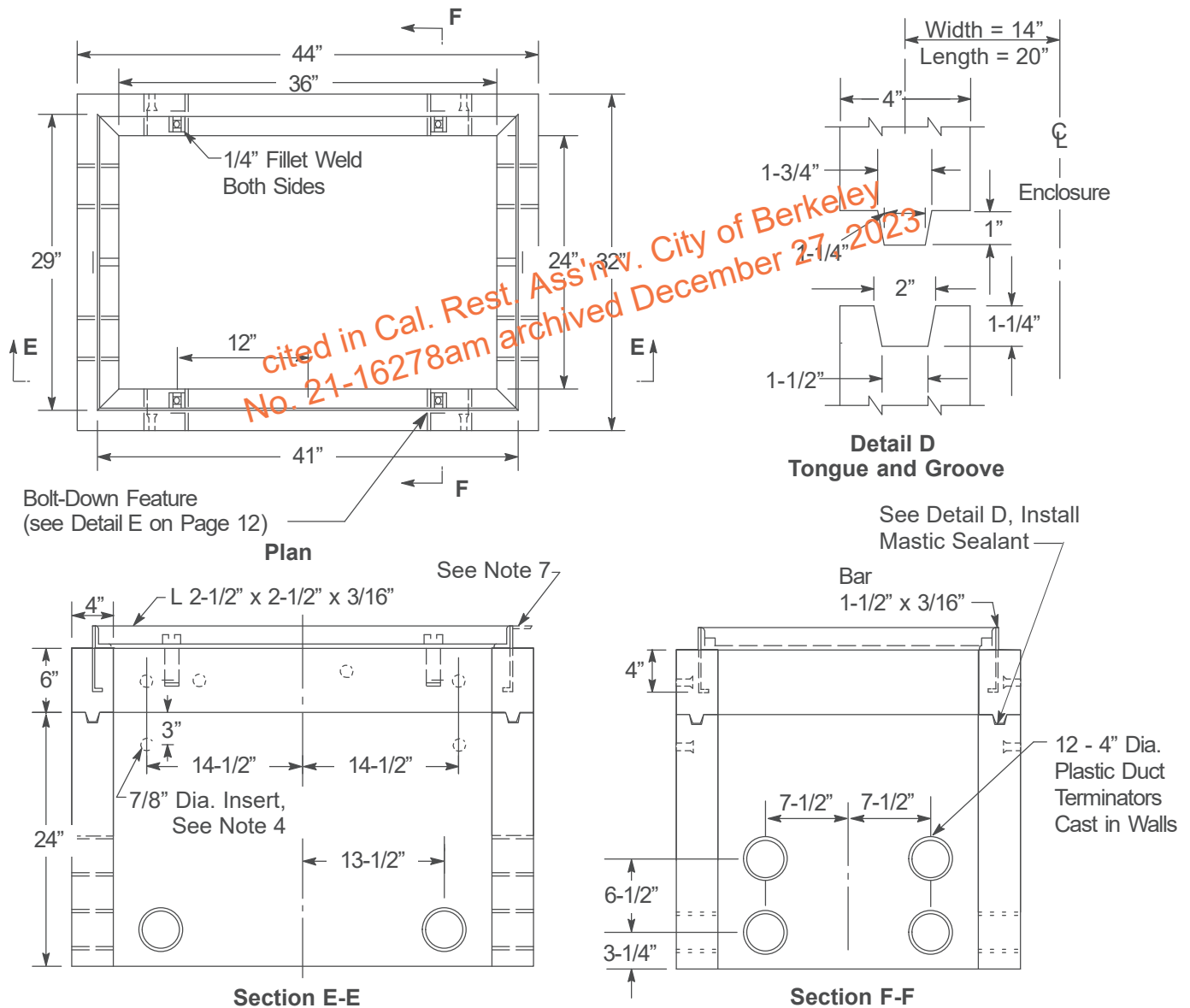
**Figure 8 17" x 30" Cover**

### Secondary Electric Underground Enclosures

#### 24" x 36" (#3) Concrete Boxes for Full-Vehicular Traffic

**Notes**

1. Grade adjustment, when required, shall be made between the box and the extension or top section.
2. A base is not required.
3. All concrete parts shall be permanently identified as to the manufacturer on the inside surface. The weight shall be stenciled on the outside of all concrete parts.
4. All concrete parts shall be provided with four 7/8-inch diameter, 1-3/4-inch minimum deep inserts with UNC Class 2A threads.
5. Joint must be interchangeable with those shown in Detail D.
6. Install mastic sealant provided with enclosure assembly for all concrete-to-concrete joints below surface level.
7. The identification plate is an integral part of the cover and should be included by the manufacturer.
8. For new construction conduits shall enter the enclosure using 90 degree elbows rising into the enclosure. Refer to Figure 5 and Figure 6 on Page 7.

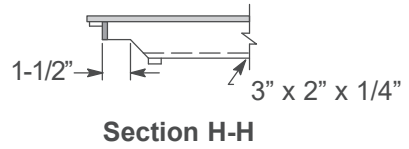
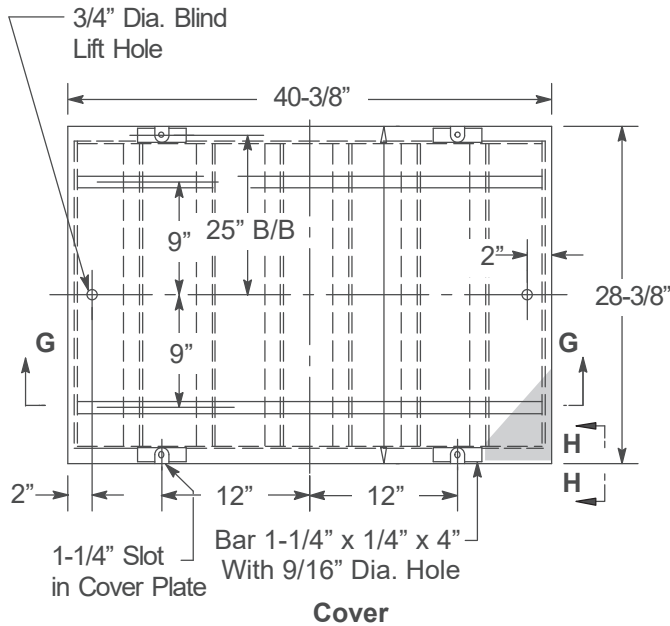


cited in Cal. Rest. Ass'n v. City of Berkeley  
 No. 21-16278am archived December 27, 2023

**Figure 9**  
**24" x 36" Concrete Box**

### Secondary Electric Underground Enclosures

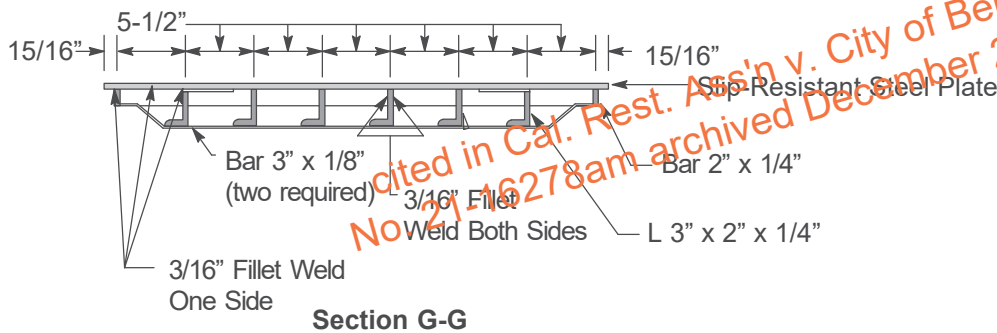
### 24" x 36" (#3) Concrete Boxes for Full-Vehicular Traffic (continued)



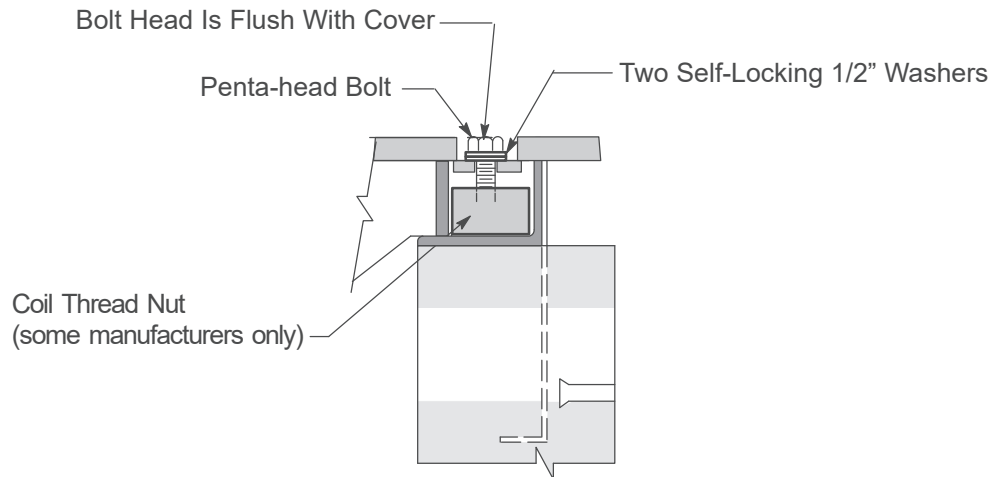
**Table 7 Codes for Complete 24" x 36" Concrete Box Assemblies**

Box		Code <sup>1</sup>
Type	Depth	
Full-Vehicular-Traffic With Slip-Resistant Cover	30"	019598
	36"	019599
Extension	6"	043521

<sup>1</sup> PG&E assembly code includes body, 6" or 12" top section with cast-in frame and cover. If more depth is required, order a 6" extension.



**Section G-G**



**Detail E Bolt-Down Feature**

**Figure 10 24" x 36" Steel Cover**

### Secondary Electric Underground Enclosures

### 36" x 60" (#5) Incidental, Full-Vehicular Traffic and Heavy Full-Vehicular Traffic Concrete Boxes

**Notes**

1. Joints must be interchangeable with those shown in Detail F.
2. Install mastic sealant included with the enclosure assembly for all concrete-to-concrete joints below surface level.
3. Pulling irons shall be designed for 20,000 pounds ultimate, with a safety factor of 2 (40,000 pounds).
4. Boxes shall be lifted using pulling irons in the floor.
5. For new construction, a 12" extension is required.
6. Install Full-Vehicular Traffic (FVT) enclosure assembly with quick-release covers in locations not subject to high-density traffic with speeds exceeding 25 mph. Typical allowable locations are alley, residential driveways and parking strips.

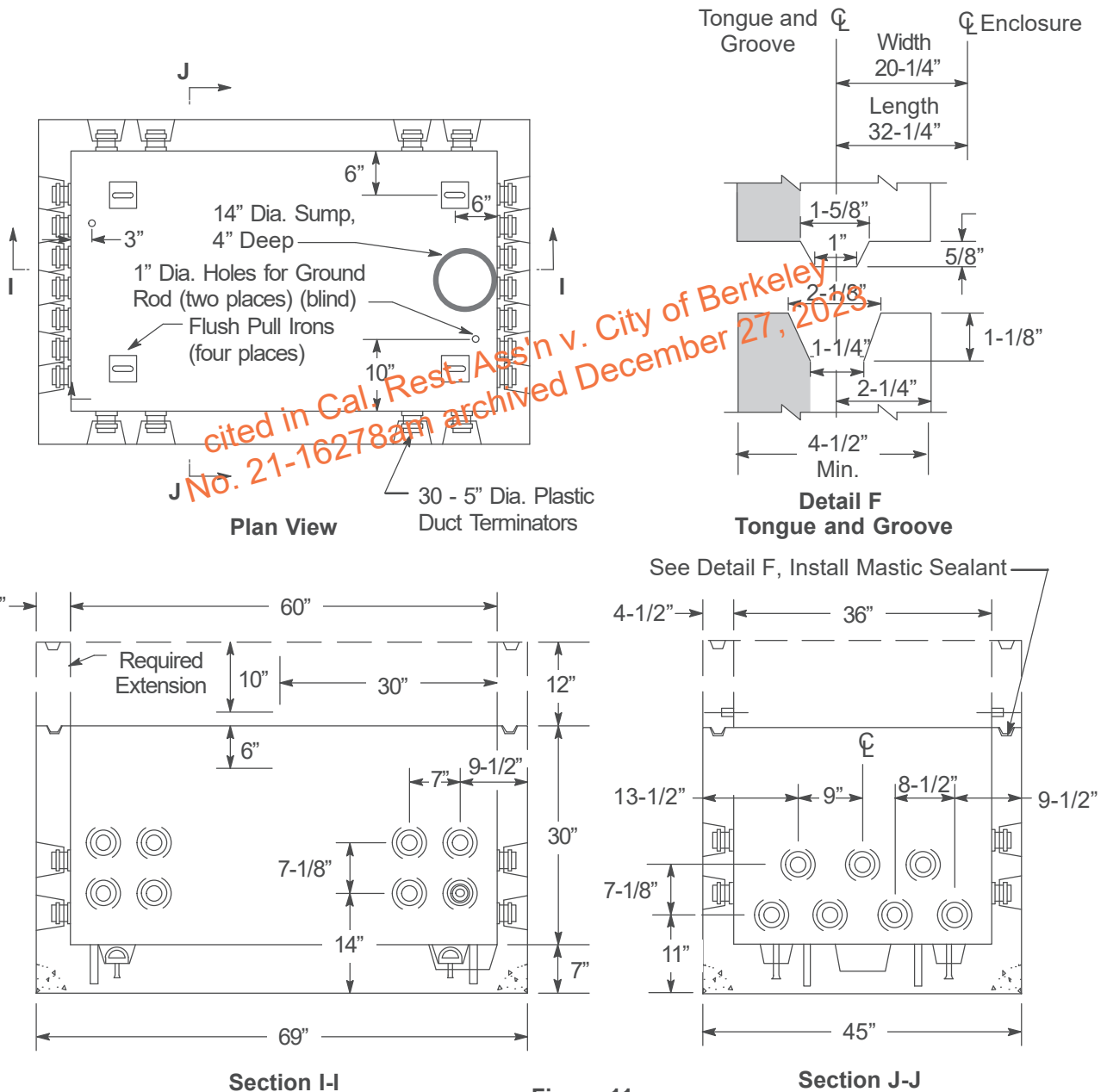


Figure 11  
36" x 60" Concrete Box



### Secondary Electric Underground Enclosures

## 36" x 60" (#5) Incidental, Full-Vehicular Traffic and Heavy Full-Vehicular Traffic Concrete Boxes (continued)

**Table 8 Codes for 36" x 60" Concrete Box**

Box		Code
Type	Depth	
Incidental-Traffic Assembly	30"	032506
Full-Traffic Assembly		042019
Heavy Full-Traffic Assembly		032507 <sup>1</sup>
Body	12"	032508
Extension		043362



<sup>1</sup> This code includes a 12" extension to accommodate the heavy full-traffic cover.

### Revision Notes

Revision 22 has the following changes:

1. Update Asset Type, Function, and document owner's name on Page 1.
2. Clarify Note 5 on Page 2 with reference to Table 19 of Document 066205.
3. Clarify Note 17 on Page 2 to allow 1" drain rock base for all enclosures with 3/4" Class 2 Aggregate Base as an acceptable alternative.
4. Remove Footnote 2 of Table 1 on Page 3.
5. Clarify Figure 5 section with 90-deg bend at conduit entry.
6. Fix Figure 7 Section B-B dimension callout.

*cited in Cal. Rest. Ass'n v. City of Berkeley  
No. 21-16278am archived December 27, 2023*

	<b>TEMPORARY UNDERGROUND ELECTRIC</b>		<b>036670</b>
	<b>SERVICE SINGLE-PHASE, 120/240 VOLT, 200 AMPS MAXIMUM</b>		
<b>Asset Type:</b>	Electric Metering	<b>Function:</b>	Design and Construction
<b>Issued by:</b>	Quoc Hoang (QxH1) 	<b>Date:</b>	07-31-15
<b>Rev. #04:</b> This document replaces PG&E Document 036670, Rev. #03. For a description of the changes, see Page 4.			

**This document is also included in the following manuals:**

- [Gas and Electric Service Requirements \(Greenbook\)](#)
- [Electric Meter Work Practices](#)

**Purpose and Scope**

This document shows minimum requirements for a customer-installed wood post or portable structure for temporary installation of a single-phase 120/240 V 200-amp maximum underground electric service. PG&E cannot establish service to posts which do not meet these minimum requirements. The maintenance of customer-owned service posts in conformity with these requirements is the sole responsibility of the customer.

**General Information**

1. Local ordinances may include requirements in addition to those shown in this document. Consult local inspection authorities for these requirements. In areas where local ordinances require permits and inspection, these must be obtained before PG&E can establish service. Meters will be installed and energized by PG&E after the customer's metering equipment has been properly installed and after an inspection clearance has been given to PG&E by the appropriate electrical inspection authority.
2. Definition of a "temporary service." Service for enterprises or activities which are limited to one year or less in duration.
3. If temporary overhead wires are to be extended from poles, the poles shall conform to requirements of [G.O. 95](#), as shown in [Document 025055](#).
4. Customer shall install conduit and cable as required by local codes.
5. The customer must contact the Underground Service Alert (USA) or PG&E to locate and mark underground facilities in the work area. Failure to do so can result in injury to personnel and/or costly damage to utility facilities.
6. When single-phase service larger than 200-amps or three-phase service is desired, consult PG&E.
7. Service Post Installation (see Page 3)
  - A The use of temporary service posts shall be restricted to installation of a temporary nature, such as building construction, temporary sales locations, etc. Temporary service posts shall be furnished and installed by the customer. If the temporary service is to be established at the permanent meter location, consult PG&E.
  - B Minimum dimensions of posts shall be 4" x 6" x 7' 0" long and depth of setting shall be 24 inches minimum.
  - C Post installations shall be in protected locations, out of the way of vehicular traffic or other hazardous conditions.
8. Service to Substantial Portable Structure (see Page 4)
  - A Portable buildings, such as small sheds, combined office/toilet structures, etc., are not considered to be substantial structures unless staked in place in the manner shown in Figure 3 on Page 4.
  - B Temporary underground service to a portable building will only be connected to a substantial portable structure. For definition of substantial portable structure and method of installation, see Figure 3 on Page 4, Note 8A on Page 1, and Note 1 on Page 4.

**Temporary Underground Electric Service Single-Phase, 120/240 Volt, 200 Amps Maximum**

9. Grounding

The customer shall be responsible for bonding and grounding all exposed non-current-carrying metal parts. Grounding shall be in accordance with the National Electrical Code and local ordinances except that the grounding wire shall be protected against mechanical damage by rigid steel conduit or armored copper ground wire may be used (minimum #8 AWG copper). For installation, see Figure 1 on Page 3.

10. Service Trench

The minimum conduit depth shown in Figure 1 on Page 3 and Figure 3 on Page 4, may be reduced from 24 inches to 18 inches for the length of the customer's service trench. However, in the vicinity of PG&E's splice box, the conduit depth must be 24 inches to assure proper entry into boxes' conduit knockout. Splice boxes without extensions do not require a 24-inch trench depth at the box location. Contact PG&E to determine if the splice box has an extension.

<b>References</b>	<b>Location</b>	<b>Document</b>
<a href="#">Requirements for Customer-Owned Poles</a> .....	<a href="#">OH: Services</a> .....	<a href="#">025055</a>
<a href="#">Rules for Overhead Electric Line Construction</a> .....	<a href="#">Technical Information Library</a> .....	<a href="#">G.O. 95</a>

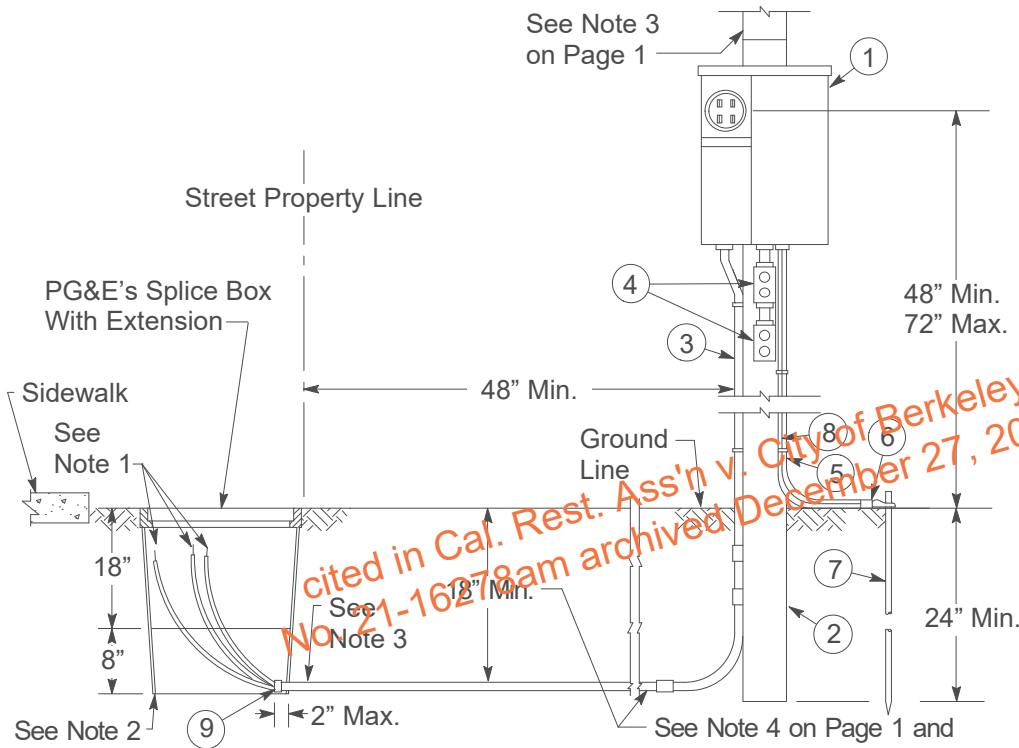
*cited in Cal. Rest. Ass'n v. City of Berkeley  
No. 21-16278am archived December 27, 2023*

**Temporary Underground Electric  
 Service Single-Phase, 120/240 Volt, 200 Amps Maximum**

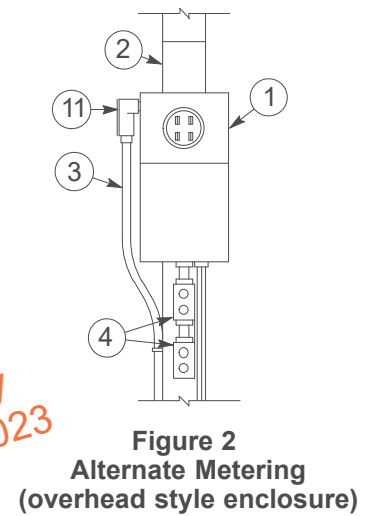
**Service Post Installation**

**Notes**

1. The customer's cables will be connected by PG&E. The customer is to contact PG&E when they are ready to extend the conduit and cable into the splice box. Customer runs adequately insulated unstripped cable into the splice box. Customer's cables are to extend a minimum of 24 inches into the splice box.
2. PG&E secondary splice box is normally located adjacent to the sidewalk. Consult PG&E for exact location. If a splice box is not present, PG&E will install an appropriate splice box at the customer's expense.
3. Conduit is to enter the splice box through knockout positions only.
4. Meter height can be reduced to a minimum of 36" if the meter is enclosed or guarded by a hinged protective hood.



*cited in Cal. Rest. Ass'n v. City of Berkeley  
 No. 21-16278am archived December 27, 2023*



**Figure 1  
 Service Post Metering  
 Preferred Installation**

**Figure 2  
 Alternate Metering  
 (overhead style enclosure)**

**Table 1 Materials to be Furnished and Installed by the Customer**

Item	Description
1	Service Termination Enclosure, Combination Meter Socket Panel
2	Post, Minimum Dimension 4" x 6" x 7' 0" Long (see Note 7B on Page 1)
3	Conduit, Rigid Steel, Galvanized, or Schedule 80 Pvc 1-1/2" Minimum I.D. for #2 or 1/0 Aluminum Service Cable
4	Weatherproof Outlets
5	Conduit, Rigid Steel, Galvanized, With Pipe Strap (for bare ground wire, omit if armor clad wire used)
6	Hub and Clamp, Grounding, to Suit Item 5
7	Ground Rod (see Note 9 on Page 2)
8	Ground Wire, Copper, Bare or Armor Clad (size in accordance with applicable electrical codes and local requirements)
9	Conduit Bushing or Bell End (as required)
10	Service Termination Enclosure, 8" x 12" x 4", Rain-Tight, Circle AW No. R-9007A or Equivalent (see Note 2 on Page 4)
11	Conduit Fitting, Threaded With Cover and Gasket (size to suit Item 3)

### Temporary Underground Electric Service Single-Phase, 120/240 Volt, 200 Amps Maximum

#### Commercial Service to Substantial Portable Structure

##### Notes

1. Structure Anchoring: To prevent overturning, the structure is required to be securely anchored in place using one of the following methods:
  - A. Four 2" x 4" minimum wood stakes driven a minimum of 24 inches into the ground and attached to the framework of the structure using 1/4-inch minimum bolts or lag screws.
  - B. Four steel stakes having strength equivalent to 3/4-inch rigid steel pipe driven a minimum of 24 inches into the ground and attached to the framework of the structure using 1/4-inch minimum bolts or lag screws.
  - C. Four steel stakes having strength equivalent to 3/4-inch rigid steel pipe driven a minimum of 24 inches into the ground with a cross member of each stake firmly contacting the upper surface of the timber used as a base or skid for the structure.
  - D. Methods A and B described the *preferred* methods of attaching the stakes to the structure framework. However, four 16d (8 gauge 3-1/2") common nails per stake may be used in lieu of the bolts or lag screws, providing the wood is in good enough condition to permit a secure attachment.
2. Item 10 may only be used if the service conductor is 1/0 AWG or smaller.

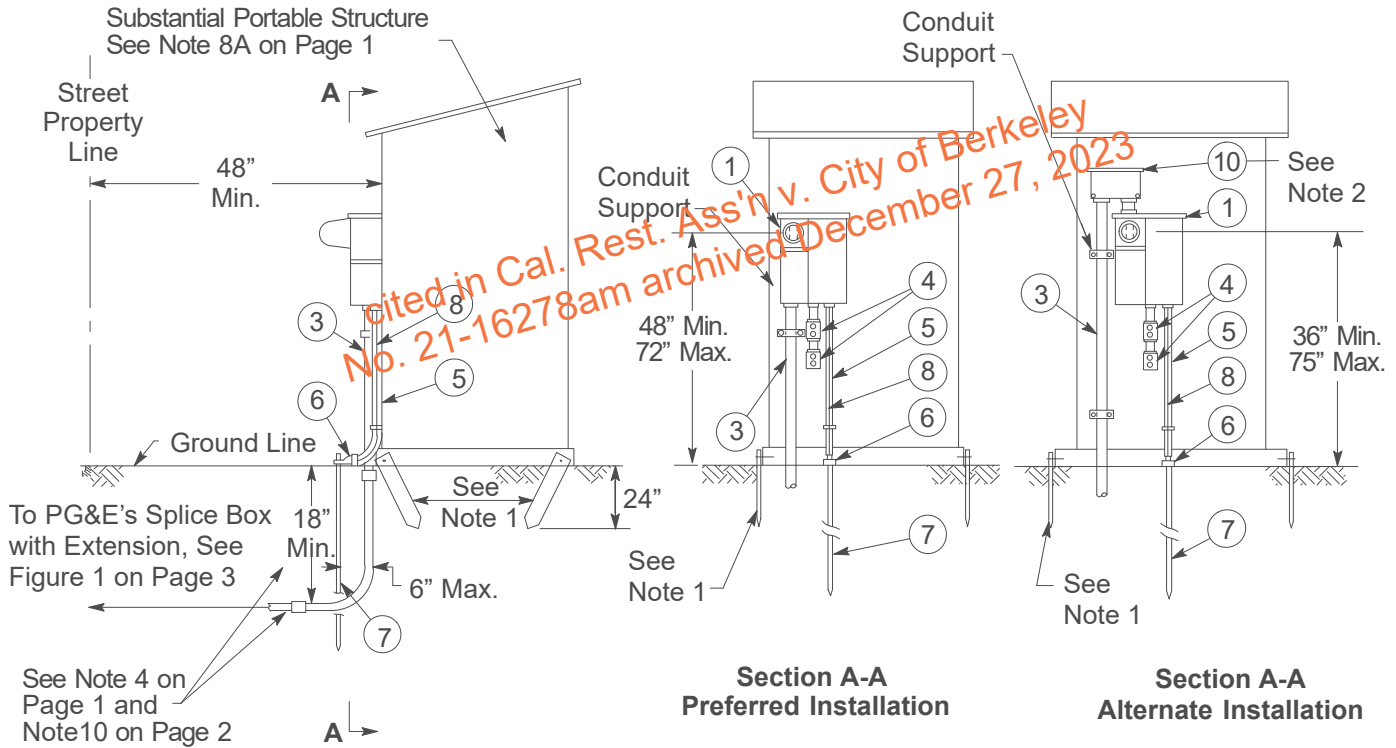




Figure 3  
Portable Structure Metering

##### Revision Notes

Revision 04 has the following changes:

1. Revised 100 Amp to 200 Amp maximum.
2. Revised Note 1 on Page 3 :customer is to contact PG&E when they are ready to extend the conduit and cable into the splice box.

Prepared by: MZGD

	<b>MINIMUM REQUIREMENTS FOR THE DESIGN AND INSTALLATION OF ELECTRIC CONDUIT, INSULATED CABLE, AND FACILITIES</b>		<b>038193</b>
	<b>Asset Type:</b> Electric Distribution	<b>Function:</b> Design and Construction	
<b>Issued by:</b> Lisseth Villareal (LDV2) 	<b>Date:</b> 03-25-22		
<b>Rev. #15:</b> This document replaces PG&E Document 038193, Rev. #14 For a description of the changes, see Page 27.			

**Purpose and Scope**

This document describes the minimum requirements for the design and installation of electric conduits and pulling insulated cables. This document also provides requirements of what facilities are allowed within the same enclosure.

**General Information**

1. A minimum of 24 inches of cover for secondary (0 – 750 V) electric service, or 36 inches minimum cover for primary (over 750 V) is required for electric trench only. Cover is the distance from the outer surface of an underground facility to the top of the final grade. The actual trench depth will be greater (approximately 30 inches or 42 inches minimum respectively) to accommodate the underground facility, bedding, enclosures, riser sweeps, and joint trench installations with other utilities.
2. For detail information for joint trench requirements see [S5453, Exhibit B](#).
3. There is no cut-off date of when a cable needs to be installed after it has been manufactured if the cable meets the following parameters
  - A. Cable is manufactured by a currently approved supplier and meets PG&E approved standard design cable requirements.
  - B. Cable was properly stored at PG&E applicant or contractor facility, i.e. properly sealed with end caps at both ends so no water/debris could have entered the cable at any time.
  - C. The cable is in good condition, i.e. no damage on the jacket, or any other layers.
  - D. Print line is fully legible.
4. For riser to riser primary conduit runs, a PG&E approved primary enclosure is required to be installed near the base of one of the riser poles to facilitate cable installation and removal.
5. Refer to the utility procedure [TD-2002P-01](#) "Installing underground Cable in Conduits" for a description on the methods for pulling underground cables into and out of conduits. This utility procedure also includes the types of equipment needed for the pulling operation. Situations, methods, and equipment may vary based on the material and jobsite.
6. Electric conduits installed using horizontal directional drilling (HDD), can be installed without any separation between the conduits when installed in the same bore. However the current carrying capacity (ampacity) of the cables can be reduced when multiple load carrying cables are installed in close proximity. Refer to [Document 050166](#) or [Document 050167](#) or consult with the responsible planning engineer.
7. Design requirements for less frequently encountered field conditions such as bio swells, railroad, bridge and septic tank/leach field, are listed on Page 9 through Page 13.
8. Percent fill table for rigid PVC DB 120 conduit has moved to end of this document and it is shown for reference only. Percent fill table for currently approved rigid PVC schedule 40 conduit is shown on Table 9 on Page 19.

### Minimum Requirements for the Design and Installation of Electric Conduit, Insulated Cable, and Facilities

#### General Information (continued)

- 9. There are many variables involved in designing underground electric conduit systems and installing cables that are peculiar to each installation and cannot be covered in this document. Some of these variables are listed below:
  - A. Physical requirements of the installation.
  - B. Limitations of available cable-pulling and reel-handling equipment.
    - (1) 1,000 pounds maximum for a single grip, 2,000 pounds maximum for two or more grips.
    - (2) 10,000 pounds maximum for reusable mechanical pulling eyes.
  - C. Number and radius of sweeps.
    - (1) Sidewall bearing pressure (1,000 pounds x radius).
  - D. Deflections, changes in direction, and obstructions encountered during conduit installation.
  - E. Coefficient of friction (COF) between cable and conduit surfaces.
  - F. Maximum allowable pulling tension for the cable size under consideration.
  - G. Conduit, cable, and facilities installation must comply with the job design and construction documents. When deviation from the original design is required due to field conditions, the originating engineering department must be notified and will determine if the deviation will require additional Substructures. Follow the variance request procedure. See [Document TD-2951P-01](#).

References	Location	Document
<a href="#">Cables for Underground Distribution</a>	<a href="#">UG-1: Cable</a>	<a href="#">039955</a>
<a href="#">600-Amp Separable Insulated Connectors</a>	<a href="#">UG-1: Terminations</a>	<a href="#">051071</a>
<a href="#">Ampacity of Underground Distribution Insulated Aluminum Cables</a>	<a href="#">UG-1: Cable/EPM</a>	<a href="#">050166</a>
<a href="#">Ampacity of Underground Distribution Insulated Copper Cables</a>	<a href="#">UG-1: Cable/EPM</a>	<a href="#">050167</a>
<a href="#">Underground Conduits</a>	<a href="#">UG-1: Conduits/Greenbook</a>	<a href="#">062288</a>
<a href="#">Methods and Requirements for Installing Residential Underground Electric Services 0 – 600 V to Customer-Owned Facilities</a>	<a href="#">UG-1: Services/Greenbook/EDM</a>	<a href="#">063927</a>
<a href="#">Methods and Requirements for Installing Non-Residential Underground Electric Services 0 – 600 Volts to Customer-Owned Facilities</a>	<a href="#">UG-1: Services/Greenbook/EDM</a>	<a href="#">063928</a>
<a href="#">Request for Variance Distribution Standards</a>	<a href="#">TIL</a>	<a href="#">TD-2951P-01</a>
<a href="#">Installing Underground Cable in Conduit</a>	<a href="#">TIL</a>	<a href="#">TD-2002P-01</a>
<a href="#">Electric Distribution Conduits Installed on Bridges</a>	<a href="#">TIL</a>	<a href="#">TD-2310P-10</a>
<a href="#">Horizontal Directional Drilling Manual</a>	<a href="#">TIL</a>	<a href="#">TD-4135M</a>
<a href="#">Electric Design Manual</a>	<a href="#">TIL</a>	<a href="#">TD-9001M</a>
<a href="#">Casings for Highway and Railroad Crossings</a>	<a href="#">TIL</a>	<a href="#">A-70</a>
<a href="#">Casing Insulator and End Seals Selection Chart</a>	<a href="#">TIL</a>	<a href="#">A-73</a>
<a href="#">Modular Wall and Casing Seal</a>	<a href="#">TIL</a>	<a href="#">A-74</a>
<a href="#">Joint Trench Configurations &amp; Occupancy Guide Exhibit B</a>	<a href="#">TIL</a>	<a href="#">S5453, Exhibit B</a>
<a href="#">Electric Design Manual Chapter 2</a>	<a href="#">TIL</a>	<a href="#">TD-9001M</a>
<a href="#">Electric Design Manual Chapter 3</a>	<a href="#">TIL</a>	<a href="#">TD-9001M</a>
<a href="#">Electric Design Manual Chapter 5</a>	<a href="#">TIL</a>	<a href="#">TD-9001M</a>

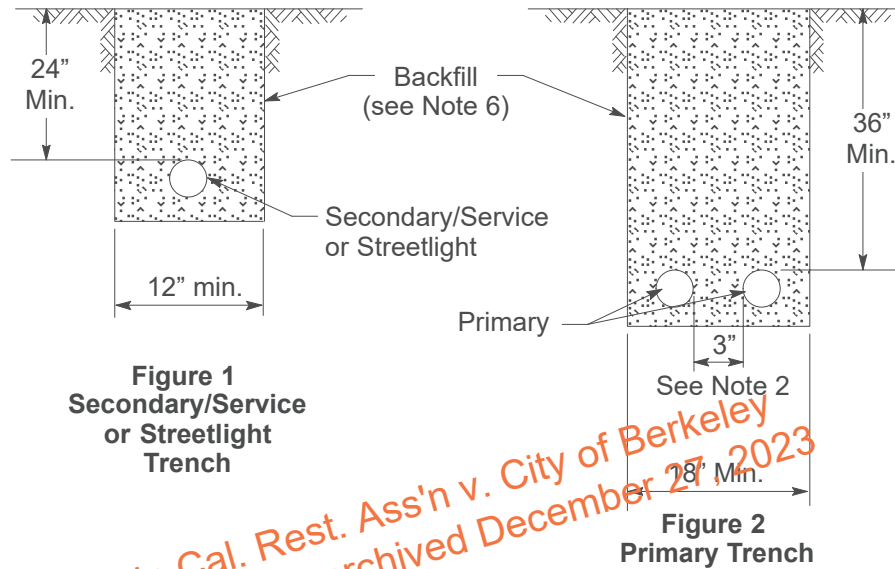
cited in Cal. Rest. Ass'n v. City of Berkeley  
 No. 21-16278am archived December 27, 2023

## Minimum Requirements for the Design and Installation of Electric Conduit, Insulated Cable, and Facilities

### Trench Requirements

#### Notes

- Field conditions may require a minimum depth greater than shown in Figure 1 and Figure 2 below.
  - Preferred maximum depth from final grade to the bottom of the trench is 60 inches.
  - When needed to avoid obstacles, maximum depth from final grade to the bottom of the trench is 120 inches.
  - Trenches deeper than 120 inches require a variance. Follow the instructions found in [Utility Procedure TD-2951P-01](#) to submit a variance request.



- Joint trench requirements are specified in the [Utility Standard S5453](#). The table showing the minimum separation and clearance requirements for joint trench is listed in "[Joint Trench](#)," [Exhibit B](#). However, this table was last updated July 31, 2015 via a bulletin. The updated table is shown in Section 3.3.8 of Greenbook and for convenience it is also shown below:

**Table 1 Joint Trench Requirements \*\*\***

		MINIMUM SEPERATION AND CLEARANCE REQUIREMENTS (Inches)						
		G	DUCT T	BD T	C	S	P	SL
G	(Gas)	-	12	12	12	6	12	6
T	(TELEPHONE) DUCT	12	-	1	1	12	12	12
T	(TELEPHONE) DIRECT BURY	12	1	-	1	12	12	12
C	(CATV)	12	1	1	-	12	12	12
S	(ELECTRIC SECONDARY)	6	12	12	12	1.5	3	1.5
P	(ELECTRIC PRIMARY)	12	12	12	12	3	3	3
SL	(STREETLIGHT) SEE NOTE 5 ****	6	12	12	12	1.5	3	1.5
FE*	(FOREIGN ELECTRIC SOURCES. NON-PG&E) SEE NOTE 5 ****	12	12**	12**	12**	12	12	12

1 \* Must be considered a "Utility" as defined in [Utility Standard S5453](#), "[Joint Trench](#)".  
 2 \*\* For exceptions, refer to G.O. 128 rule, section B. Items (1) and (2).  
 3 \*\*\* These clearances/separations supersede old clearances/separation shown in [S5453 Exhibit B](#).  
 4 \*\*\*\* It is preferred to have non-PG&E owned streetlights at a level other than the gas or electric level. Non-PG&E owned streetlights may be at the electric level of the trench as long as minimum clearances are provided and comply with all special notes for a joint trench with a second electric utility.



## Minimum Requirements for the Design and Installation of Electric Conduit, Insulated Cable, and Facilities

### Trench Requirements (Continued)

#### Notes

3. For independently installed electric trenches, most of the requirements are the same as for joint trenches. However, Table 2 below shows and clarify requirements when installing electric trench only.

**Table 2 Minimum Separation and Clearance for Electrical Conduit by Facility Type<sup>5</sup>**

Facility	Minimum Parallel Separation	Minimum Crossing Separation
Between multiple electric primary conduits	3 inches	6 inches
Between electric primary and secondary, service and streetlight conduits	3 Inches	6 inches
Between electric secondary, service and streetlight conduits	1.5 inches	6 inches
Between electric primary and gas distribution main and service conduits	12 inches	12 inches
Between electric secondary, service, streetlight and gas main and gas service conduits	12inches	6 inches
Leach field and electric primary, secondary, service and streetlight conduits	10 feet <sup>1</sup>	Not Allowed <sup>2</sup>
Steam lines from PG&E electric conduits	10 feet <sup>3</sup>	18 inches <sup>3</sup>
Tree trunk from PG&E electric primary, secondary, service, and streetlight conduits	5 feet <sup>4</sup>	5 feet <sup>4</sup>
Diesel or other volatile liquids; propane or other volatile, heavier-than-air gases and any type of electrical conduit	20 feet	20 feet
Edge of Underground gas tank and any type of electric conduits	10 feet	10 feet
Hydrogen cooling block, dispenser or storage and any type of electric conduit	5 feet	5 feet
Hydrogen compressor and any type of electric conduit	15 feet	15 feet
Any other pipe systems or other foreign substructures excluding wet facilities not listed above	12 inches	6 inches

<sup>1</sup> If this separation cannot be achieved, refer to the [Septic Tank/Leach Field/Leach](#) Line section starting on [Page 9](#).

<sup>2</sup> Mobile home park is the only exception, refer to the [Septic Tank/Leach Field/Leach](#) section starting on [Page 9](#).

<sup>3</sup> If this separation cannot be achieved, refer to the [Steam Line](#) section starting on [Page 12](#).

<sup>4</sup> Radial distance from the closest edge of the trunk to the edge of electric conduit.

<sup>5</sup> Wet facility requirements are the same as listed in [S5453](#).

4. Separations in Table 1 and Table 2 may be reduced when conduits are entering enclosures, panels, pads, vaults, or structures. Allowance must be made for the installation of the conduit end bell fittings.
5. Sharp turns, bends, or other irregularities in the conduit must be avoided.
6. If the bottom of a trench which will contain plastic conduit is rocky, use backfill material conforming to the requirements of [Engineering Material Specification 4123](#). Before tamping in the area of plastic conduit, apply at least 6 inches of backfill over the top of the conduit to avoid breakage. Final backfill may then be placed in the trench and tamping employed to finish grade. The soil originally removed from the trench should be used as backfill wherever possible.
7. Do not use salt-water sand backfill with steel conduit.
8. Other utility practices may require a greater minimum conduit separation.
9. Refer to state of California, Department of Industrial Relations; Trench Construction Safety Orders for trench construction requirements. These orders are issued by the Department of Occupational Safety and Health.

## Minimum Requirements for the Design and Installation of Electric Conduit, Insulated Cable, and Facilities

### Conduit System Design and Installation

To minimize the possibility of cable damage during installation, the following conduit design parameters must be followed:

1. The total number of factory bends installed in conduit run for primary cable must not exceed 300 degrees, including the bend at the feed-in location. Only factory bends are allowed.
2. The total number of factory bends installed in conduit runs for secondary cable and services having a maximum length of 200 feet must not exceed 315 degrees, including the bend at the feed-in location. If the total length of conduit run exceeds 200 feet, then the total number of factory bends for secondary and service cable must not exceed 300 degrees.
3. The maximum length of any straight conduit run (no factory bends) must not exceed 1,200 feet.
4. The calculated pulling tension for the non-preferred (highest) direction must be used as the limiting pulling tension.
5. When the conduit run includes bends (300 degrees or less), the maximum length of the run must be limited to 800 feet.
6. For secondary, services, and 200-Amp primary applications, the conduit run must not exceed 600 feet if there is a vertical 90 degree bend at both ends of the conduit run.
7. The first 18 inches of conduits entering or leaving any primary or secondary underground 3' x 5' or larger enclosure must be straight with no bends, couplings, or swedge reducers.
8. To avoid potential burn-through of sweeps, use polyester pulling tape (material code **M560154**) as the "P-Line" to initiate cable pulling. For further information refer to [Utility Procedure TD-2002P-01](#) "Installing Underground Cable in Conduit".

For each primary cable run, the construction drawing must contain:

- A. The calculated pulling tension.
  - B. A preferred direction of pulling.
  - C. The maximum allowable pulling tension.
  - D. A place to record the actual pulling tension and direction of pull.
9. The tension on the pulling line, as seen on the dynamometer, is dependent on the number of rollers and sheaves used to rig the pulling line and the angle between the line entering and leaving the device. Multiply the calculated pulling tension on the cable by 5% for each 90° bend of the rope.
  10. The pulling equipment specified for a job should be capable of twice the calculated pulling tension. This is recommended due to the following variables:
    - A. Back tension.
    - B. Condition of the conduit.
    - C. Temperature of the conduit, cable, and the ambient air temperature.
    - D. Increase in friction due to rigging.
    - E. Static (start/stop) friction.

Combinations of the above could increase the actual pulling tension to twice (or more) of the calculated tension. Attention should be paid to minimizing these factors.

### Minimum Requirements for the Design and Installation of Electric Conduit, Insulated Cable, and Facilities

#### Conduit System Design and Installation (continued)

#### Cable Pulling Requirements

To minimize issues during cable pulling, follow the steps below:

1. The use of approved pulling practices and equipment is required.
2. Before starting any cable installation or removal operation, all employees must be thoroughly familiar with the safe operation of the equipment and methods to be used.
3. Provide a reliable means of communications between feed-in and pull-out locations before and during the entire operation.
4. Provide an adequate number of employees to safely install or remove the cable.
5. The conduit must be cleared of dirt, rocks, or other debris before starting the cable installation.
6. The practice of attaching the pulling rope to a vehicle and then driving the vehicle to pull in or remove cable may damage the cable and is prohibited.
7. All cable must be lubricated (pre-lubed) before installing (see Table 6 on Page 7 and Table 7 on Page 8).
8. The use of a dynamometer or inline tensiometer to monitor the pulling tension during cable installation is **recommended** for cable pulls where the calculated pulling tension is less than 50% of the maximum allowable pulling tension for the cable being installed.
9. The use of a dynamometer or inline tensiometer to monitor the pulling tension during cable installation is **required** for cable pulls where the calculated pulling tension is equal to or greater than 50% of the maximum allowable pulling tension for the cable being pulled.
10. All locations where the actual pulling tensions exceed the calculated tensions by more than 25% must be reported to the originating engineering department and analyzed to determine the cause of the difference. The information will be used to improve the design parameters as well as E&E's cable-pulling practices.
11. The minimum radius bend that an insulated cable can be subjected to cannot exceed the results of the OD of the cable times the multiplier shown in Table 3.

**Table 3 Minimum Allowable Cable-Bending Radius Multiplier**

Type of Cable	Multiplier
P&L or PL&N	10
15 and 22 kV XLP-PVC	12
5-35 kV CONC-PVC, LLDPE Encap, or EPR-CONC-PE	8
600 V XLP and EPR&N	5 (500 kcmil and larger)
	4 (less than 500 kcmil)

12. The recommended amount of cable lubricant depends only on the size and length of the conduit system.

The appropriate quantity for use on any given pull can vary from this recommendation depending on the complexity of the pull. Consider the following factors:

- A. Cable weight and jacket hardness (increase quantity for stiff, heavy cable).
- B. Conduit type and condition (increase quantity for old, dirty, or rough conduits).
- C. Conduit fill (increase quantity for conduit fills of 50% or greater).
- D. Number of bends (increase quantity for pulls with several bends).
- E. Pulling environment (increase quantity for high temperatures).

13. Front-end packs are conduit-sized polyethylene bags of lubricant. The packs are attached to the winch line, ahead of the cable, and are manually opened as they enter the conduit, pre-lubing the conduit. Codes for front-end packs are in listed Table 4 on Page 7 .

## Minimum Requirements for the Design and Installation of Electric Conduit, Insulated Cable, and Facilities

### Conduit System Design and Installation (continued)

#### Cable Pulling Requirements (continued)

**Table 4 Pulling Lubricant**

Description	Code
Front-End Pack 2" and 3" Conduit	500118
Front-End Pack 4", 5", and 6" Conduit	500117
Pourable Lubricant, 2.5-Gallon Container	500031
Pourable Lubricant, 5-Gallon Container	500099

14. Cable lubricant LZ type must be used when 500 kcmil, 750 kcmil, and 1100 kcmil Cu 15kV EPR flat strap with low smoke zero halogen (LSZH) jacketed cable is pulled through conduits. For more information regarding LSZH cable refer to [Document 039955](#).  
 Note: The use of standard pulling lubricant will have a negative impact on the physical integrity of the cable's LSZH jacket.

**Table 5 Pulling Lubricant to be Used With LSZH Cable**

Description	Code <sup>6</sup>
Lubricant, Squeezable Quart	500060

<sup>6</sup> 12 quarts is the minimum order quality.

15. Table 6 Below and Table 7 on Page 8 indicate the approximate amount of pulling lubricant for various cable pulls. Same tables apply for the lubricant LZ type.

**Table 6 Pulling Lubricant Needed for 2", 3", and 4" Conduit**

Pull Length (feet)	2" Conduit			3" Conduit			4" Conduit		
	Gallons Needed	Number of Front-End Packs	Pourable (gallons)	Gallons Needed	Number of Front-End Packs	Pourable (gallons)	Gallons Needed	Number of Front-End Packs	Pourable (gallons)
100	0.25	1	0	0.50	2	0	0.50	1	0
200	0.50	2	0	1.00	2	0.50	1.00	2	0
300	1.00	2	0.50	1.25	2	0.75	2.00	2	1.00
400	1.25	2	0.75	1.75	2	1.25	2.50	2	1.50
500	1.50	2	1.00	2.25	3	1.50	3.00	2	2.00
600	1.75	3	1.00	2.75	3	2.00	3.50	3	2.00
700	2.00	4	1.00	3.25	4	2.25	4.00	4	2.00
800	2.50	4	1.50	3.50	4	2.50	5.00	4	3.00
900	2.75	4	1.75	4.00	4	3.00	5.50	4	3.50
1,000	3.00	4	2.00	4.50	4	3.50	6.00	4	4.00

**Minimum Requirements for the Design and Installation of Electric Conduit, Insulated Cable, and Facilities**

**Conduit System Design and Installation (continued)**

**Cable Pulling Requirements (continued)**

**Table 7 Pulling Lubricant Needed for 5” and 6” Conduit**

Pull Length (feet)	5” Conduit			6” Conduit		
	Gallons Needed	Number of Front-End Packs	Pourable (gallons)	Gallons Needed	Number of Front-End Packs	Pourable (gallons)
100	1.00	2	0	1.00	2	0
200	1.50	3	0	2.00	2	1.00
300	2.50	2	1.50	2.50	3	1.00
400	3.00	2	2.00	3.50	3	2.00
500	4.00	2	3.00	4.50	3	3.00
600	4.50	3	3.00	5.50	4	3.50
700	5.50	4	3.50	6.50	4	4.50
800	6.00	4	4.00	7.00	4	5.00
900	7.00	4	5.00	8.00	6	5.00
1,000	7.50	5	5.00	9.00	6	6.00

*cited in Cal. Rest. Ass'n v. City of Berkeley  
No. 21-16278am archived December 27, 2023*

## Minimum Requirements for the Design and Installation of Electric Conduit, Insulated Cable, and Facilities

### Design Requirements for Less Frequently Encountered Field Conditions

#### Conduit and Substructure Installation

Conduit and substructure installation must comply with the job design and construction documents. If field conditions require a deviation that is not within current standards, follow the variance request procedure. See [Document TD-2951P-01](#).

The requirements listed below are for the various field conditions where electric conduits are installed;

#### Bio Swale

It is preferred to install conduit around a bio swale. If it is not feasible to go around the bio swale, primary and/or secondary conduits under the bio swale must be installed following the requirements below:

1. Option #1
  - A. Install conduits with a minimum cover of 48" between the top of the conduit and the bottom of the bio swale.
  - B. Add 6" sand bed below conduit
  - C. Use PVC Schedule 40, and install a spare conduit
  - D. Install conduit 36" past bio swale on each side
  - E. Add 6" sand bed on top of conduit
  - F. Complete trench fill with native dirt
2. Option #2 (if option #1 is not feasible)
  - A. Install conduits with a minimum cover or 36" between the top of the conduit and the bottom of the bio swale.
  - B. Add 6" sand bed below conduit
  - C. Install PVC Schedule 40, and install spare conduit
  - D. Run conduit 36" past bio swale on each side
  - E. Add 6" sand bed on top of conduit
  - F. Add 3" Red Slurry Cap
  - G. Complete trench fill with native dirt
3. Option #3
  - A. Use horizontal directional drilling (HDD) to install conduits crossing under existing bio swales. For more information about HDD, Refer to [Utility Procedure TD-4135M](#).
  - B. The minimum depth burial for HDD is 48" from the bottom of existing bio swales.

#### Railroad

Railroad crossing may require electric conduits installation in a casing via HDD. For information about casing specifications, casing sealing, casing spacers refer to [A-70](#), "[Casings for Highway and Railroad Crossings](#)", [A-73](#), "[Casing Insulator and End Seals Selection Chart](#)", and [A-74](#), "[Modular Wall and Casing Seal](#)".

#### Bridge

For the design requirements of conduits installed on bridges see [Utility Procedure TD-2310P-10](#).

#### Septic Tank/Leach Field/Leach Line

Leach fields are used to dispose of sewage from septic-tank sanitary sewer systems. Typically, leach fields consist of a system of rock-filled trenches with drain line or perforated pipe and weir-type diversion boxes. They are grade-sensitive and create a wet environment.

Septic tanks and Leach fields are considered an unreasonable interference for UG distribution electric line easements. Substructure conduit connections are not designed to be used under pressure and are not air tight. As a result, sewage may enter the conduit and result in unsafe working conditions.

## Minimum Requirements for the Design and Installation of Electric Conduit, Insulated Cable, and Facilities

### Design Requirements for Less Frequently Encountered Field Conditions (continued)

#### Septic Tank/Leach Field/Leach Line (continued)

Ensure that the entire leach field is located outside the right of way or easement of PG&E electric facilities.

Septic tanks are installed underground. The potential of seepage or leaks from cracks is a concern. Therefore, septic tanks are unacceptable in any right of way or easement of PG&E electric facilities. Variance requests for this requirement will not be considered and they will be denied.

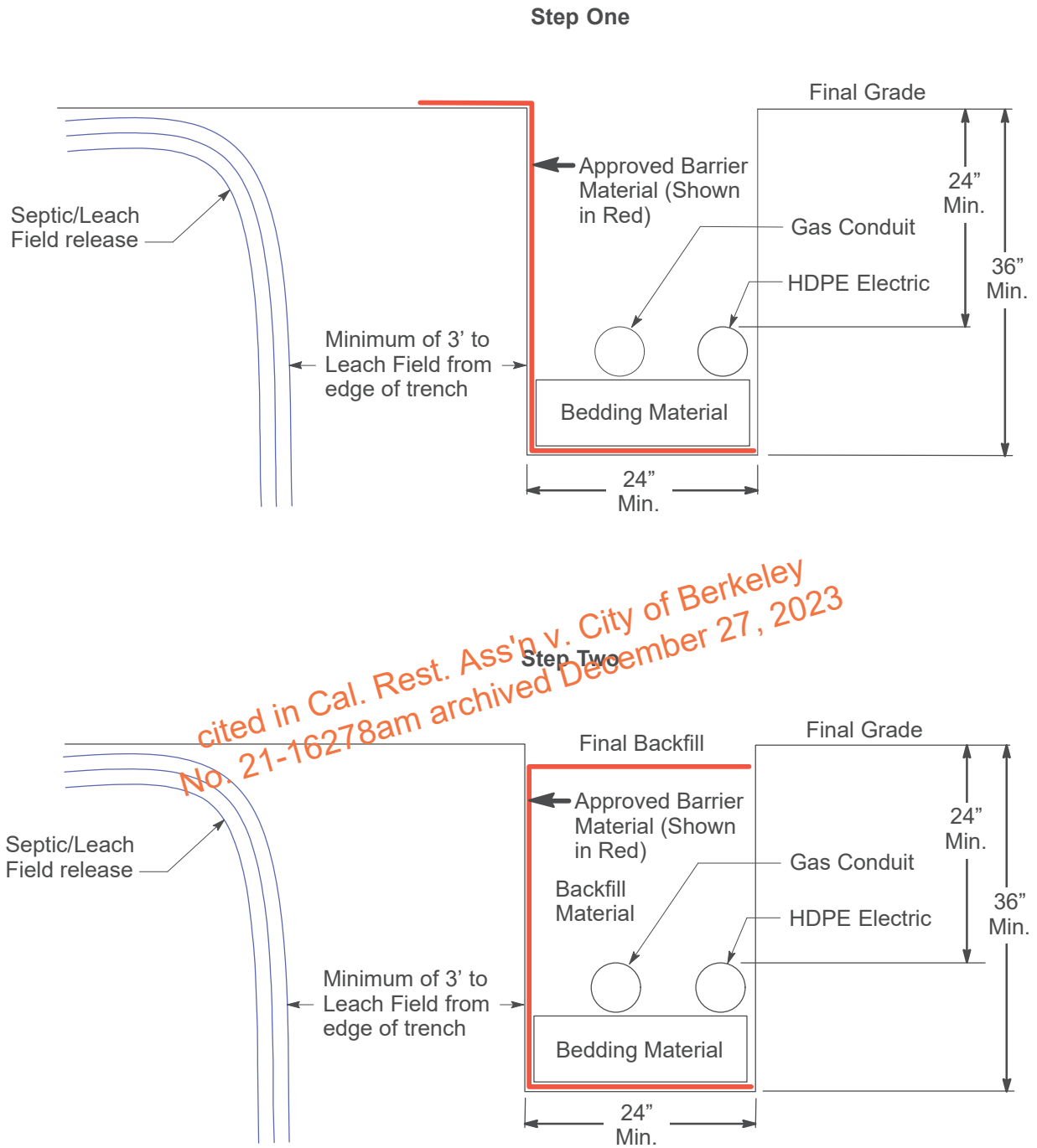
A horizontal distance of 10 feet away from the septic tanks and or leach systems must be maintained. Crossing over or underneath septic tank/leach lines is not allowed (see note 5e for the only exception). Installation of PG&E underground electric facilities across a new leach field is not allowed.

When all alternatives have been considered, and it is not feasible to achieve 10 feet of horizontal separation from the septic tank/leach lines, install PG&E underground facilities maintaining as much separation as possible. The minimum horizontal separation must not be less than 3 feet. Follow the steps listed in the notes below.

#### Notes:

1. Leach fields are regulated by Counties. Therefore, Counties may have different restrictions. The more stringent requirements must be followed. Without a written authorization from the Counties where the leach field is located, there will be no variances consideration for the installation of PG&E underground facilities within 10' from the septic tank/ leach system.
2. Provide valid evidence that it is not feasible to physically install PG&E electric underground facilities 10' away from septic tank and leach field. Cost alone is not a valid reason.
3. Provide detail information of the location of the septic tank and leach field indicating what part of the leach field is solid pipe and where does the perforated pipe start. Most of the release will likely happen soon after the transition from the solid to perforated pipe.
4. Provide the direction of the field grading in relation to the service trench.
5. Mitigate the hazards created by not installing underground facilities 10' away from the septic tank/leach field by meeting the following requirements:
  - A. Use a continuous run of HDPE conduit to avoid any effluent infiltration. Building a seal conduit system is the best way to mitigate migration of the contaminants.
  - B. Seal both ends of HDPE conduits entering and leaving the leach field.
  - C. Install electric enclosure 10' away from the septic or leach lines.
  - D. Install the approved laminated film (**M602637**) as the suitable barrier between the leach field and the service trench when the trench is outside of the leach field, but unable to meet the 10' separation requirement. Figure 3 on Page 11 illustrates the proper installation of the laminated film barrier material. The instructions listed below explain the steps illustrated in Figure 3.
    - (1) Step One: Install the laminated film barrier material (shown in red) into the empty trench so that it covers the trench floor; it will rise up the wall of the trench and be laid on the ground on the leach field side of the trench. Laying the barrier material over the top side of the trench will allow for the barrier material to be held in place while backfilling. The barrier material will later overlap the top of the trench as described on step two. Install the bedding material to pin barrier material down and install conduits as far from the septic tank/leach field/leach line as possible.
    - (2) Step Two: Begin backfilling and soil compaction to a level that allows for the barrier material to be laid over the backfill covering the top of the trench near final grade. Note that the barrier is placed before final grade is achieved. Finally, complete backfill and soil compaction to final grade.
  - E. Avoid crossing an existing leach field, mobile home park projects are the only exception to this rule. All other possible design alternatives must be considered before designing PG&E electric underground facilities across an existing leach field. The leach field is contaminated, therefore, no need to install a barrier as it will have no effect.

### Minimum Requirements for the Design and Installation of Electric Conduit, Insulated Cable, and Facilities



**Figure 3**  
Installation of Laminated Film Barrier (M602637) for Leach Field Application



## Minimum Requirements for the Design and Installation of Electric Conduit, Insulated Cable, and Facilities

### Design Requirements for Less Frequently Encountered Field Conditions (continued)

#### Steam Lines

Steam lines present the potential problem of leaking even when they are insulated. Steam leaks migrate through the ground and into electric substructures resulting in damage of our electric conduits and cables. To mitigate the high temperature effects of the steam, the installation of a thermal insulation is required when our electric facilities cannot meet the following requirements,

–PG&E electric facilities must maintain a distance of 10 feet away from the steam line when paralleling, and a distance of 3 feet away when crossing over or underneath steam lines.

–Steel conduits are not allowed to be used within a radius of 10 feet from steam lines.

When all alternatives have been considered, and it is not feasible to achieve the required separation between PG&E electric facilities from the steam lines, the installation of a thermal insulation barrier is required. Install PG&E underground facilities maintaining as much separation as possible. Even with the installation of the thermal insulation barrier, the minimum horizontal separation must not be less than 3 feet, and the minimum vertical separation must not be less than 12 inches.

PG&E approves two installation methods for achieving a thermal insulation barrier between PG&E electric facilities and steam lines.

Method 1: Use of Fluidized Thermal Backfill (FTB) or Thermal Select Backfill

After PG&E has inspected and approved the duct bank or underground structure, the trench must be backfilled with native backfill, FTB, or thermal select backfill. Permit agencies may require specific backfill materials for areas within their jurisdiction. Approval of the backfill material is required before its use in the trench. The proposed material must have a thermal resistivity of not more than 60 C-cm/watt at critical moisture content (8% for FTB) and 90 C-cm/watt at 0% moisture content.

FTB is an engineered material that has very low thermal resistivity. FTB is a low-cement concrete with a fluidizing agent to fill unwanted voids. Fluidizing fly ash must be used along with the standard concrete aggregates of pea gravel and sand. The low strength mix must have a maximum nominal compressive strength of 70 – 300 psi. Higher compressive strength is unacceptable because of the difficulty of trenching above the duct bank or conduit.

Thermal select backfill must be placed to enhance heat dissipation. This backfill consists of limestone screenings, cement and water, mixed into a slurry to facilitate placement. The contractor must provide the mix proportions for thermal select backfill to PG&E inspection for review, and must obtain approval for thermal resistivity of the backfill from Geotherm, Inc.

Milpitas Materials Company is a PG&E-approved supplier of select backfill. It is located in Milpitas, CA.

The following is a representative mix design:

Limestone screenings: 1 cubic yard (approximately 3,000 lbs.).

Cement: 3/4 sacks (approximately 70 lbs.) per cubic yard of limestone

Water: 55 –60 gallons (approximately 544 lbs.) per cubic yard of limestone (depending on the moisture content of the limestone)

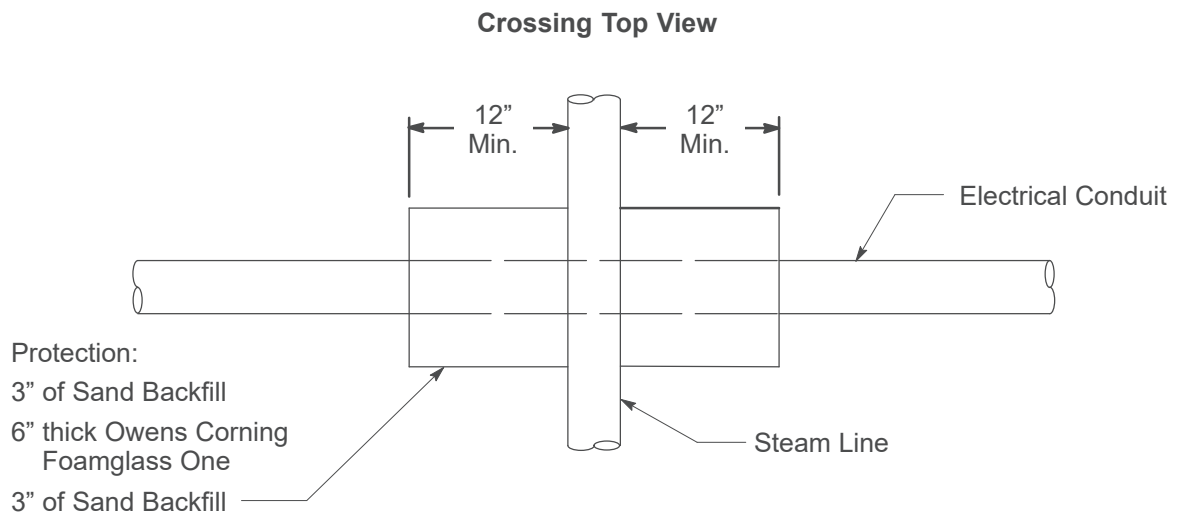
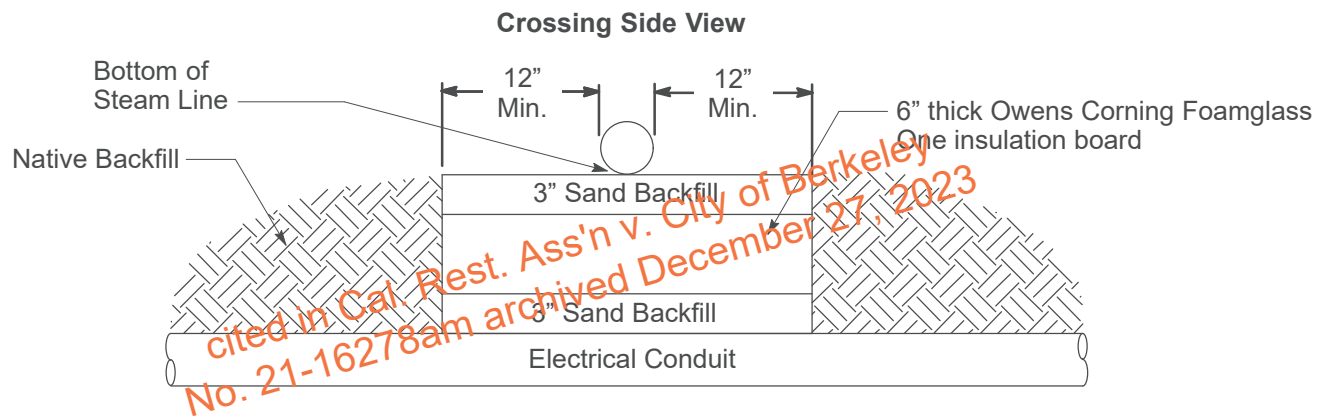
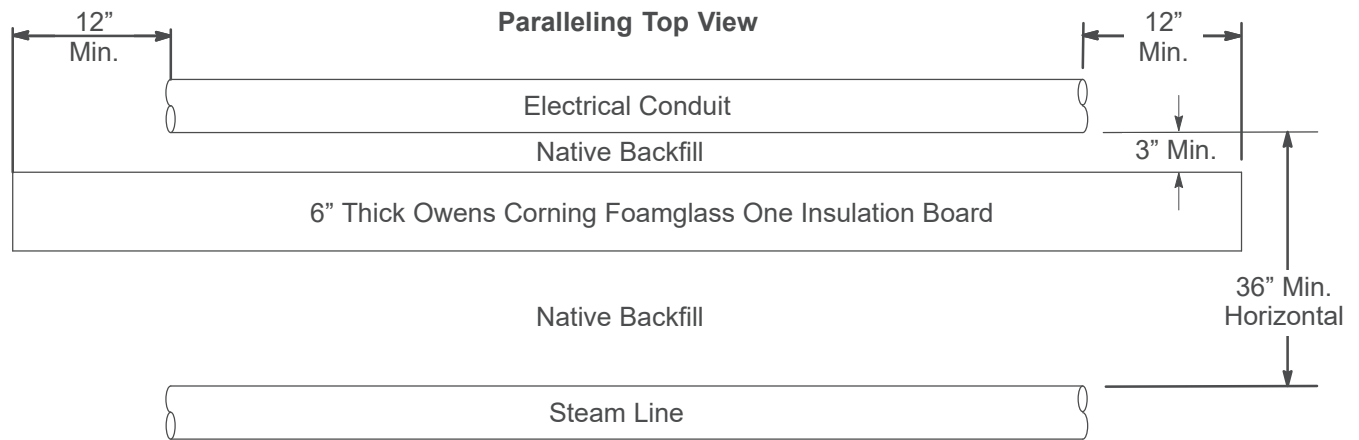
Method 2: Use of FOAMGLAS® ONE™ Insulation Barrier.

FOAMGLAS® ONE™ insulation is a lightweight, rigid material composed of millions of completely sealed glass cells. It is manufactured by Owens Corning in a block form and then fabricated into a wide range of shapes and sizes. This approved material is not coded. PG&E employees need to order this material as non-coded material using Ariba. The approved FOAMGLAS® ONE™ insulation may be of 3" minimum thickness of the FOAMGLAS® ONE™, but 6" is preferable.

Configure each of the FOAMGLAS® ONE™ in a running bond brick pattern, so there is no gap between each block for the entire length electric conduits are installed less than the required separation from the steam line.

Install the approved Owens Corning FOAMGLAS® ONE™ insulation material as shown in Figure 4 on Page 13.

### Minimum Requirements for the Design and Installation of Electric Conduit, Insulated Cable, and Facilities



**Figure 4  
 Steam Line**

## Minimum Requirements for the Design and Installation of Electric Conduit, Insulated Cable, and Facilities

### Material and Equipment Design Requirements and Restrictions

1. Two different 600-Amp or 200-Amp primary circuits of the same or different voltage are permitted in the same enclosure if each circuit is racked on opposite walls.
2. No more than one set of 600-Amp separable connectors is allowed in any one enclosure. One set means three 600-amp separable assembly. Figure 5 below shows one 600-Amp separable assembly.
3. No more than three 600-Amp elbows are allowed in any one 600-Amp separable assembly.
4. No more than one set of 200-Amp taps (piggy-backed) off of a set of 600-Amp separable assembly is allowed
  - A. A 200-Amp tap from a 600-Amp separable assembly must be made with a load-break reducing tap plug (RTP) and a 200-Amp load-break elbow receptacle, as shown in [Document 051071](#), "600-Amp Separable Insulated Connectors". See Figure 5.
  - B. Only one such connection is allowed between two 600-Amp main line switches.

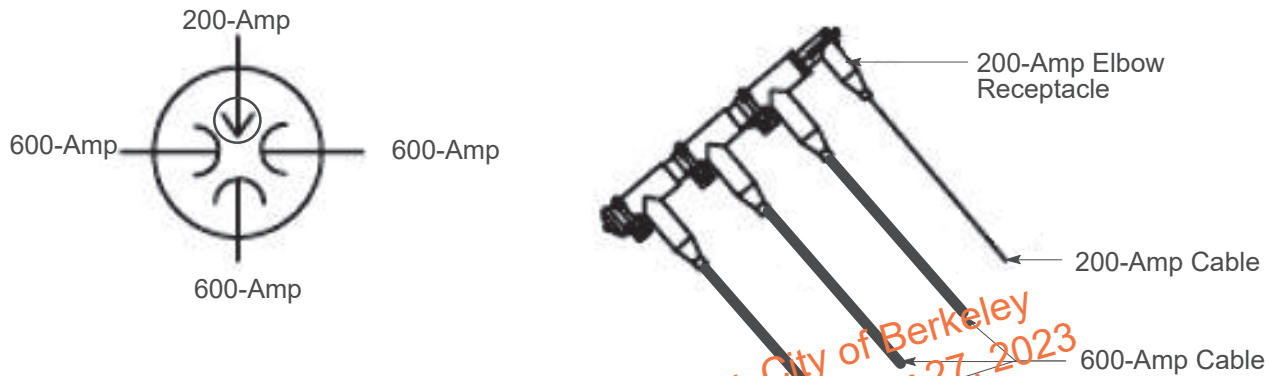
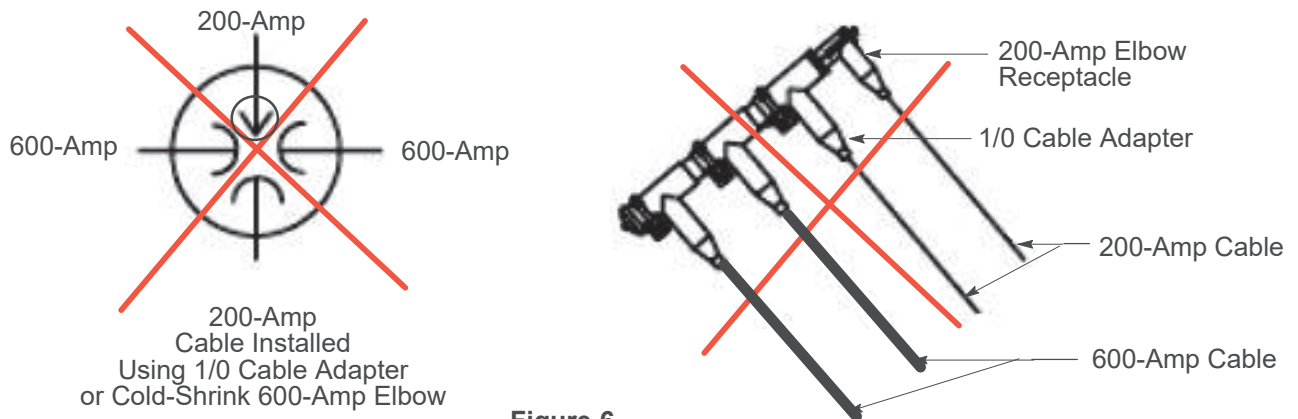


Figure 5  
Allowed 600-Amp Separable Splice Assembly

5. 600-Amp three-phase switching devices are required at all critical main-line intersections. Consult with the responsible electric distribution planning engineer for direction during the project's design phase.
6. Only one set of 600-Amp separable assembly is allowed between two 600-Amp main-line switches. However, for all main-line junctions, three phase switching devices are required.
7. No more than four-ways of cable on a 600-Amp subsurface switch is allowed.
  - A. A way is a conduit run from point A to point B. It can be one, two or up to three cables.
  - B. It is not allowed to tap off (piggy-back) 600-Amp elbows on top of each other 600-Amp elbows on the same switch bushing at any time. See Note 9 under Cable and Equipment in [Document 050859](#)
  - C. It is not allowed to tap off (piggy-back) 200-Amp taps off subsurface switches.
  - D. Subsurface switch bushings that are rated at 600-Amps may be converted to 200-Amps by using a bushing extension and a 600/200-Amp tap/plug.
  - E. 200-Amp taps that utilize 600-Amp bushing extensions are not considered piggy-back.
  - F. SCADA installation on 600-Amp subsurface switch is exempt from requirement 7. However, whenever possible install SCADA on 600-Amp subsurface switches with no 200-Amp tap (piggy-backed).
8. No more than four-ways of cable on a 200-Amp pad-mounted or subsurface junction is allowed.
9. It is not permissible to use 1/0 cable adapters with 600-Amp separable connectors to make a 200-Amp tap. See Figure 6 on Page 15. Material code for the 1/0 cable adapters is still active to be used for replacement of existing facilities only. See [Document 051071](#).
  - A. For SCADA jobs that require the installation of a 600-Amp switch on a 200-Amp application using 1/0 AI XLPE 15kV/22kV rated cable (previously installed standard cable) or currently approved 1/0 AI EPR 25kV rated cable; it is allowed to use cold-shrink 600-Amp elbow (**M301641**).

## Minimum Requirements for the Design and Installation of Electric Conduit, Insulated Cable, and Facilities

### Material and Equipment Design Requirements and Restrictions (continued)



**Figure 6**  
**Not Permissible 600-Amp Separable Splice Assembly**

10. When necessary, use one of the following three options to establish additional 200-Amp tap from existing mainline cables that already has 600-Amp separable assembly with one existing 200-Amp tap.

**Option 1.**

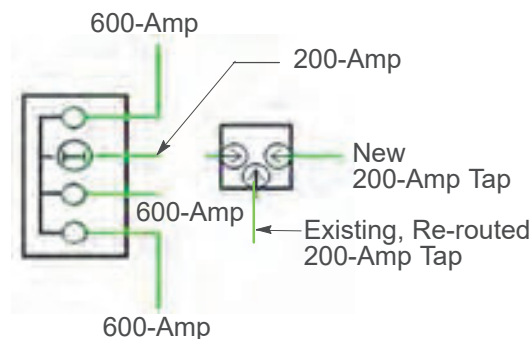
Leave existing 600-Amp separable assembly. Intercept and re-route existing 200-Amp tap to a new 200-Amp interrupter (install the 200-Amp interrupter as close as possible to the existing 600-Amp separable assembly). Extend the 200-Amp tap from the load side of 200-Amp interrupter and install a 200-Amp subsurface or pad-mounted junction. This installation is shown in Figure 7 below.



**Figure 7**  
**Upgrade Existing 200-Amp Tap**

**Option 2.**

Replace existing 600-Amp separable assembly with a pad-mounted switch, such as PMI-11, install a 200-Amp subsurface or pad-mounted junction with existing and new two 200-Amp taps. This installation is shown in Figure 8 below.



**Figure 8**  
**Replace Existing 600-Amp Separate Assembly with Pad-Mounted Interrupter**

## Minimum Requirements for the Design and Installation of Electric Conduit, Insulated Cable, and Facilities

### Material and Equipment Design Requirements and Restrictions (continued)

Option 3.

Install a Switch-Interrupter-Switch, 3-Way, 3-Way-Switched; extend the interrupter way and install a 200-Amp subsurface or pad-mounted junction with two 200-Amp taps. Re-route the existing 200-Amp piggy-backed of the existing 600-Amp separable assembly to one of the ways of the 200-Amp junction.

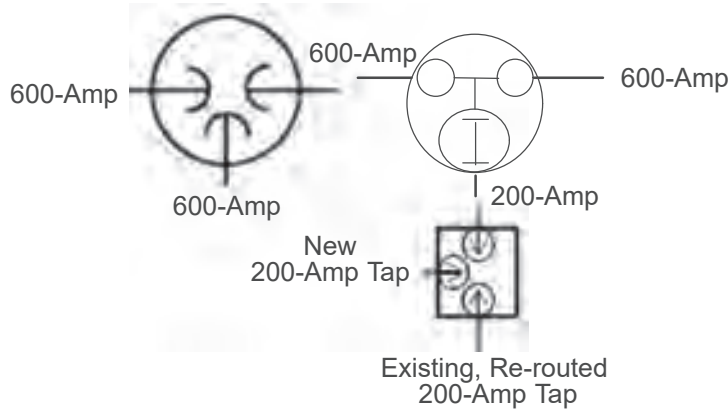


Figure 9

### Re-route Existing 200-Amp Tap to One of the Position of the 200-Amp Junction

11. Locate the protection devices as close as possible to the mainline tap when designing 200-Amp taps off the 600-Amp mainline. See examples in Figure 10 on Page 17.
12. **Do not install** the following facilities in the same enclosure (#5, #6 or #7 size).
  - A. 600-Amp separable assembly with or without 200-Amp piggy-backed tap and 200-Amp subsurface junction or any other operable equipment.
  - B. 600-Amp separable assembly with or without 200-Amp piggy-backed tap and 600-Amp straight splices.
  - C. 600-Amp separable assembly with or without 200-Amp piggy-backed tap and 200-Amp straight splices.
  - D. 600-Amp straight splices and 200-Amp straight splices installed on the same wall.
  - E. 600-Amp or 200-Amp operable equipment and 600-Amp or 200-Amp straight splices.
13. The requirements listed in Note 12 apply to new construction and reconstruction. However, if field conditions such as space constraints make it unfeasible to comply with these requirements, it is allowed for existing facilities to take exceptions to these requirements.

## Minimum Requirements for the Design and Installation of Electric Conduit, Insulated Cable, and Facilities

### Material and Equipment Design Requirements and Restrictions (continued)

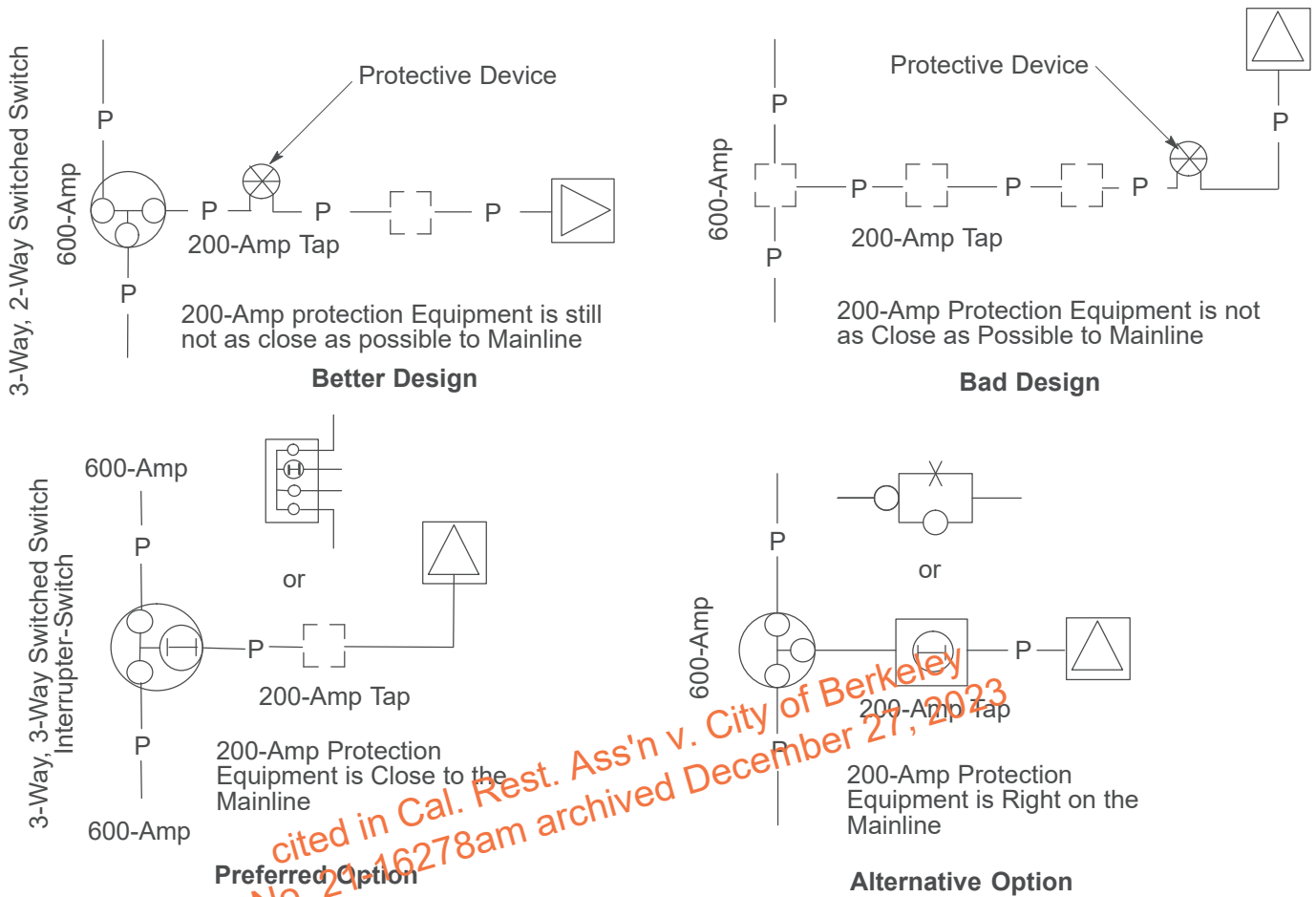


Figure 10  
 Protection Design Device Location

# Minimum Requirements for the Design and Installation of Electric Conduit, Insulated Cable, and Facilities

## Formulas and Parameters

### Notes

1. The formulas and parameters used in this document are widely used in the utility industry. The parameters that must be checked are: **Conduit Fill, Cable Configuration, Minimum Bending Radius, Cable Jamming Potential, Cable Clearance, Maximum Pulling Tension, and Sidewall Bearing Pressure Limits.**

2. Cable Jamming

Jamming is a condition that may occur if the sum of the cable diameters is about equal to the inside diameter of the conduit. It will typically occur at bends when one cable is forced between the other two cables and wedges them against the inner wall of the conduit. Jam ratios between 2.8 to 3.1 should be avoided to prevent the possibility of the cables jamming at a sweep. Use the formula given below to calculate jam ratio.

3. Jam Ratio Formula

$$J = D/d$$

Where:

J = Jam ratio

D = Conduit inside diameter (inches)

d = Cable nominal diameter (inches), one cable



Check the probability of jamming using the formula:  $J = 1.05 D/d$

### 1.05\*J = (p) probability of jamming

- If the value J is less than 2.5, jamming is unlikely to occur. Cables are in triangular configuration.
- If the value J is between 2.6 and 2.7, jamming is very possible. Cables are more likely in triangular configuration.
- If the value J is between 2.8 and 3.1, jamming is very possible. Cables can be either in triangular or cradled configuration. The risk is higher if the sidewall bearing pressure in a bend exceeds 1000 pounds/foot.
- If the value J is greater than 3.1, jamming is unlikely to occur. Cables are in triangular configuration.

Check the probability of jamming using the formula:  $P = 1.05 D/d$

$$\text{Probability of jamming (p)} = 1.05 * J$$

The 1.05 factor is to account for the oval shape of the bends in the section view.

4. Coefficient of Friction

A coefficient of friction value of 0.30 is recommended for lubricated PVC or PE conduits.

5. Minimum Bending Radius

The multipliers for determining the minimum cable bending radius for commonly used cables are listed in Table 3 on Page 6.

6. Percent Conduit Fill

Conduit fill is the percentage of area inside the conduit taken up by the cable(s).





- A. The recommended maximum percentage of conduit fill is shown in Table 8 on Page 14.
- B. The total combined percent conduit fill ratio of PG&E electric supply cable and fiber optic cable (FOC) must not exceed 75%.
- C. For new construction, the conduit is usually sized for the next-larger size of cable.

*Not cited in Cal. Rest. Ass'n v. City of Berkeley No. 21-16278am archived December 27, 2023*

## Minimum Requirements for the Design and Installation of Electric Conduit, Insulated Cable, and Facilities

### Formulas and Parameters (continue)

**Table 8 Recommended Maximum Conduit Fill**

Number of Cables	Example	Percent of Total Internal Area of Conduit to Be Filled by Cable
1		60
2		40
3		55
4		55

**Table 9 Percent Fill for Common Cable/Conduit (Rigid PVC Schedule 40) Combinations**

	Type of Cable	2"	3"	4"	5"	6"
600 V	1/0 Triplex	17%	8%	-	-	-
	4/0 Triplex	28%	13%	-	-	-
	350 kcmil Triplex	-	20%	12%	-	-
	750 kcmil Triplex	-	36% <sup>1</sup>	21%	14%	10%
	1,000 kcmil Triplex	-	-	28%	18%	-
	1/0 Quadruplex	24%	11%	-	-	-
	4/0 Quadruplex	-	18%	10%	-	-
	350 kcmil Quadruplex	-	28%	16%	11%	-
	750 kcmil Quadruplex	-	-	30%	19%	14%
1,000 kcmil Quadruplex	-	-	39%	25%	17%	
15 kV	3-#2 AWG, Cu-EPR	-	25%	14%	-	-
	3-350 kcmil, Cu-EPR	-	-	28%	18%	13%
	3-500 kcmil, Cu-EPR	-	-	34%	22%	15%
	3-750 kcmil, Cu-EPR	-	-	42%	29%	20%
	3-1,100 kcmil, Cu-EPR	-	-	-	37%	26%
	3-500 kcmil, Cu-EPR <sup>2</sup>	-	-	38%	24%	17%
	3-750 kcmil, Cu-EPR <sup>2</sup>	-	-	48%	31%	21%
	3-1,100 kcmil, Cu-EPR <sup>2</sup>	-	-	-	40%	28%
25 kV	1-1/0, Al-EPR	37%	17%	-	-	-
	3-1/0, Al-EPR	-	-	29%	-	-
	3,600 kcmil, Al-EPR	-	-	-	37%	26%
	3-1,100 kcmil, Al-EPR	-	-	-	47%	36%
	3-1,100 kcmil, Cu-EPR	-	-	-	48%	38%
34.5 kV	3-1/0, Al-EPR	-	-	14%	-	-
	3,600 kcmil, Al-EPR	-	-	-	36%	25%
	3-1,100 kcmil, Al-EPR	-	-	-	-	43%

<sup>1</sup> Although percent fill is less than 55%, it is difficult to pull 750 kcmil triplex in 3" conduit. It is acceptable to pull 750 kcmil triplex in existing 3" conduit. New construction should use 4" conduit.

<sup>2</sup> This cable has low smoke zero halogen (LSZH) jacket for indoors substations application only.



## Minimum Requirements for the Design and Installation of Electric Conduit, Insulated Cable, and Facilities

### Formulas and Parameters (continue)

#### 7. Sidewall Bearing Pressure (SBP)

Sidewall pressure is exerted on a cable as it is pulled around a bend. **The following limits are recommended:**

- A. SBP = 500 pounds/foot for one solid dielectric cable (XLPE or EPR insulation).
- B. SBP = 1,000 pounds/foot for two or more solid dielectric cables (XLPE or EPR insulation).
- C. SBP = 300 pounds/foot for PILC (lead) cables.

#### 8. Weight Correction Factor

This is an important factor to calculate because when you pull two or more cables in a conduit, the sum of the forces developed between the cables and the conduit is always greater than the sum of the individual cable weights. When you have three single cables of equal diameter and weight, you can expect a higher weight factor for the cradled position than the triangular position. Assume that the cables will sit in the cradled position (unless you are pulling triplexed cables from a single reel), because this will yield a higher and therefore more conservative pulling tension calculation.

For one or two cables

$$W_{\text{single}} = 1$$

For three cables in a cradled configuration

Where  $3 > J > 2.5$

$$W_{\text{cradled}} = 1 + (4/3) * (d/D - d)^2$$

For three cables in a triangular configuration

Where  $J < 2.5$

$$W_{\text{triangular}} = 1 \div \sqrt{1 - (d/D - d)^2}$$

For four cables (quadruplex) in a diamond configuration

Where  $J < 3.0$

$$W_{\text{diamond}} = 1 + 2 [d \div (D - d)^2]$$

#### 9. Maximum Allowable Pulling Tension

The maximum allowable pulling tension is the lesser of the allowable tension on the pulling device and the maximum pulling tension that can be applied to the conductors.

Definition of symbols:

- w = Weight Correction Factor
- f = Coefficient of Friction
- W = Cable Weight, pounds per foot
- L = Length of conduit run, in feet

#### 10. Equations to calculate pulling tension formulas

A. Tension, Horizontal Straight Section

$$T_{\text{out}} = wFL + T_{\text{in}}$$

B. Tension, Natural or Factory Bend Section (except for "D" below)

$$T_{\text{out}} = T_{\text{in}} \cosh(wf\theta) + \sinh(wf\theta) \times \sqrt{T_{\text{in}}^2 + (WR)^2}$$

Where:

$$\sinh(wf\theta) = (e^{wf\theta} - e^{-wf\theta}) / 2$$

$$\cosh(wf\theta) = (e^{wf\theta} + e^{-wf\theta}) / 2$$

And

$\theta$  = Angle of bend, in radians

R = Sweep radius

e = 2.718

## Minimum Requirements for the Design and Installation of Electric Conduit, Insulated Cable, and Facilities

### Formulas and Parameters (continue)

C. Tension, inclined and Vertical Straight Section

(1) Pulling up a Straight Section

$$T_{out} = WL (\sin (\theta) + wf \cos (\theta) ) + T_{in}$$

Where:  $\theta$  = Angle of incline

(2) Pulling down a Straight Section (utilize equation for horizontal straight section)

$$T_{out} = wfWL + T_{in}$$

D. Tension, Convex Bend at Top of Incline, Upward Pull

$$T_{out} = T_{in} e^{wf\theta} + (WR / (1 + (wf)^2)) [2wfe^{wf\theta} \sin \theta + (1 - w^2 f^2) (1 - e^{wf\theta} \cos \theta)]$$

Where:  $\theta$  = Angle of bend (same as angle of slope)

$R$  = Sweep radius

$e$  = 2.718

11. When cable is pulled through a conduit bend or around a sheave, sidewall bearing pressure (SBP) develops between the cable wall and the bend or sheave. This pressure has a dramatic effect on the sizing of the conduit system, because it relates directly to the radii of bends, pulling tension and cable's weight.

For single cable:

$$SBP = T \div R$$

For 3 cables in cradled configuration:

$$SBP = [(3w_{cradled} - 2) T] \div 3R$$

For 3 cables in triangular configuration:

$$SBP = (w_{triangular} T) \div 2R$$

For 4 cables in diamond configuration:

$$SBP = (w_{diamond} - 1) (T \div R)$$

12. It is necessary to have adequate clearance between the uppermost cable and the top of the conduit to ensure a safe and easy pull. For straight pulls, a clearance of 1/4" is safe. For pulls that include bends, a clearance of 1/2" to 1" is needed. Use the outside diameters of the circumscribing circle listed on [Document 039955](#) to determine cable clearances.

### Minimum Requirements for the Design and Installation of Electric Conduit, Insulated Cable, and Facilities

#### Determining Pulling Tension for Sections Containing Sweeps

##### Example

Given:

- Conduit layout as shown in Figure 11.
- Conduit size 6 inch, 6.11".
- Size of cables: three 1/C 1,100 kcmil Al. EPR-CONC-Encap PE, 25 kV.
- Weight of cable = 3 x 2.36 lbs. = 7.08 pounds/foot.
- Coefficient of Friction = 0.30

Find:

- If cable can be pulled without damage.
- Best direction of pull.
- What type of pulling attachment can be used.

1. The first step is to calculate conduit fill in percent:

$d = 2.05''$  from [Document 039955](#).

$D = 6.11''$  From Table 10-3 of the [Electric Design Manual](#).

$r = d/2 = 1.025''$

Cable Area =  $3\pi (d/2)^2$  or Cable Area =  $3\pi r^2$

Cable Area = 9.902 in<sup>2</sup>

Conduit Area =  $\pi (D/2)^2$

Conduit Area = 29.321 in<sup>2</sup>

Conduit Fill = (Cable Area/Conduit Area)\*100%

Conduit Fill = 33.771%

This is less than the 55% percent conduit fill allowed.

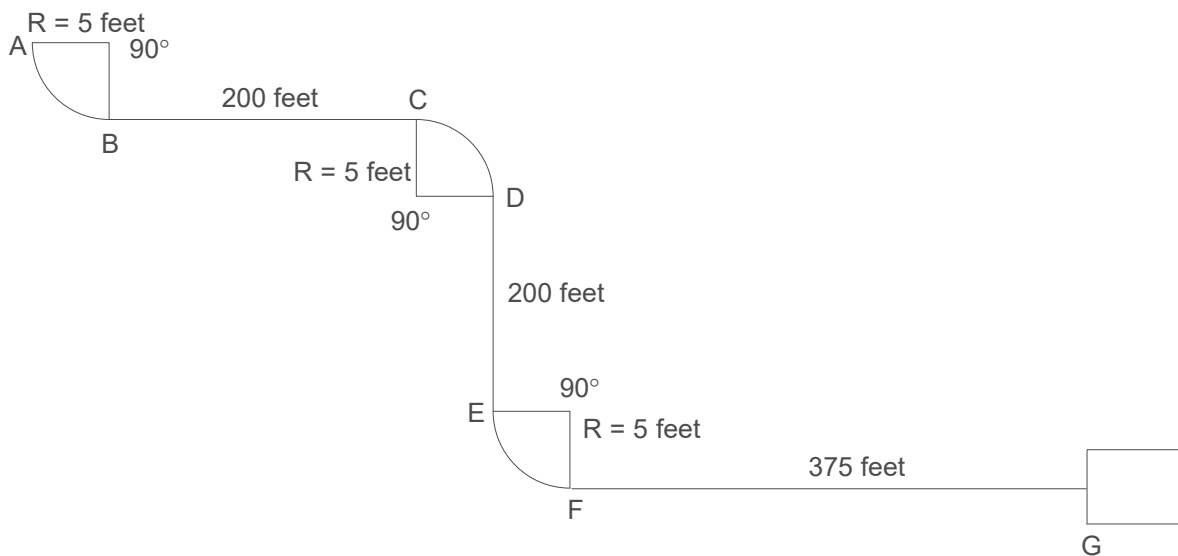


Figure 11  
Typical Duct Layout

**Minimum Requirements for the Design and Installation of Electric Conduit, Insulated Cable, and Facilities**

**Determining Pulling Tension for Sections Containing Sweeps (continued)**

2. The next step is to calculate the jam ratio to determine the cable configuration and the probabilities of cable jamming.

$$J = D/d = 2.98$$

Since this ratio is larger than 2.5 but less than 3, it is assumed that the cables are going to be in the cradled configuration. Cable clearance does not need to be checked.

Check the probability of jamming by using the following formula:

$$P = 1.05 D/d$$

$$P = 1.05 * 2.98 = 3.13$$

In this case the probability of jamming is greater than 3.1; therefore, jamming is not expected to happen.

3. The next step is to calculate the weight correction factor for this cable:

$$w_{\text{cradled}} = 1 + (4/3) * (d/D - d)^2 = 1.339$$

4. We can now proceed to calculate the pulling tensions:

$$T_{\text{in}} = 0 \quad \text{Tension at A!}$$

Tension at B is calculated using the formula for horizontal bend section:

$$W = 7.08 \text{ lbs/ft} \quad R_{\text{AB}} = 5 \text{ ft} \quad f = 0.3 \quad \theta = \pi/2$$

$$T_{\text{AB}} = T_{\text{in}} \cosh(w_{\text{cradled}} f \theta) + \sinh(w_{\text{cradled}} f \theta) \sqrt{T_{\text{in}}^2 + (WR_{\text{AB}})^2}$$

$$T_{\text{AB}} = 0 + (0.674) \sqrt{0 + (35.4)^2}$$

$$T_{\text{AB}} = 23.85 \text{ lbs}$$

Tension at C is calculated using the horizontal straight section formula:

$$L_{\text{AB}} = 200 \text{ ft} \quad T_{\text{BC}} = w_{\text{cradled}} f W L_{\text{AB}} + T_{\text{AB}} \quad T_{\text{BC}} = 568.81 + 23.85 = 593 \text{ lbs}$$

Tension at D is calculated using the formula for horizontal bend section:

$$R_{\text{CD}} = 5 \text{ ft}$$

$$T_{\text{CD}} = T_{\text{BC}} \cosh(w_{\text{cradled}} f \theta) + \sinh(w_{\text{cradled}} f \theta) \sqrt{T_{\text{BC}}^2 + (WR_{\text{CD}})^2}$$

$$T_{\text{CD}} = 715.02 + 400.22 = 1,115 \text{ lbs}$$

Tension at E is calculated using the pulling down straight section formula.

$$L_{\text{DE}} = 200 \text{ ft} \quad T_{\text{DE}} = w f W L_{\text{DE}} + T_{\text{CD}} \quad T_{\text{DE}} = 568.81 + 1,115 = 1,684 \text{ lbs.}$$

$$T_{\text{EF}} = 3,165 \text{ lbs}$$

$$T_{\text{FG}} = 4,232 \text{ lbs}$$

Since this tension exceeds the maximum allowable tension of 2,000 lbs. on pulling grips (see Table 10 on Page 25), pulling eyes are needed for this pull (10,000 lbs. limit). Also, the maximum tension on the conductor can be calculated as follows:

$$A_c = \text{Area in cmil} \quad \text{cmil} = \text{mil}^2 \quad N_c = \text{Number of Conductors}$$

$$S_c = 0.008 \text{ lbs/cmil Maximum Stress on Al or Cu conductors!}$$

$$\text{The area of 1,100 kcmil is: } A_c = 1,100,000 \text{ cmil and } N_c = 3$$

$$T_{\text{conductor}} = N_c S_c A_c = 26,400 \text{ lbs}$$

cited in Cal. Res. Ass'n v. City of Berkeley  
 No. 21-16278am archived December 27, 2023

## Minimum Requirements for the Design and Installation of Electric Conduit, Insulated Cable, and Facilities

### Determining Pulling Tension for Sections Containing Sweeps (continued)

The maximum allowable tension on these cables is the lesser value of the calculated tension on the conductor(s) and the maximum tension on the pulling device. In this case, the 10,000 lbs limit on the pulling eye is the maximum allowable tension. Refer to Table 10 on Page 25 through Table 12 on Page 26 for the maximum allowable tension on PG&E's cables.

Reverse Direction Calculations

Tension at F is calculated as follows:

$$L_{FG} = 375 \text{ ft. } T_{in} = 0$$

$$T_{GF} = w_{cradled} L_{FG} + 0 = 1,067 \text{ lbs}$$

$$T_{FE} = 2,006 \text{ lbs}$$

$$T_{ED} = 3,422 \text{ lbs}$$

$$T_{DC} = 6,432 \text{ lbs}$$

$$T_{CB} = 7,001 \text{ lbs}$$

$$T_{BA} = 13,158 \text{ lbs}$$

Since the pulling tension from G to A is greater (13,158 lbs.) than the pulling tension from A to G (4,232 lbs.), and pulling tension from G to A exceeds the 10,000 lbs maximum allowable tension on the pulling eye, cable must be pulled in the direction from A to G.

5. Finally, the sidewall bearing pressure limits need to be checked at the bends.

The pulling tensions at B and D are not very significant, but the tension at F may be a concern in terms of sidewall bearing pressure.

$$SBP = [(3w_{cradled} - 2)T_{EF}]/3R_{EF} = [(3*1.339 - 2)*3,165]/15$$

$$SBP = 426 \text{ lbs/ft}$$

As we can see, the limit of 1,000 lbs/ft for two or more solid dielectric cables is not exceeded at the bend between points E and F.

However, if any of the limits are exceeded, consider one or more of the following options:

- Increase bend radii.
- Decrease conduit fill.
- Reduce the number of bends.
- Try reverse pull.
- Pull in stages.
- Decrease length of pull.

cited in Cal. Rest. Ass'n v. City of Berkeley  
 No. 21-16278am archived December 27, 2023

**Minimum Requirements for the Design and Installation of Electric Conduit, Insulated Cable, and Facilities**

**Maximum Allowable Pulling Tensions for Various Cable Rating, Sizes, and Configurations**

**Table 10 Maximum Allowable Pulling Tensions for 1/C Aluminum or Copper XLP or EPR Insulated Cables**

Cable Rating	Cable Size AWG or kcmil	Maximum Allowable Pulling Tension (lbs.)					
		1/C per Duct		2/C per Duct		3/C per Duct	
		Grip	Pulling Eye	Grip	Pulling Eye	Grip	Pulling Eye
600 V Through 35 kV	#4	334	334	668	668	668	668
	#2	531	531	1,062	1,062	1,062	1,062
	1/0	844	844	1,688	1,688	1,688	1,688
	2/0	1,000	1,065	2,000	2,130	2,000	2,130
	4/0	1,000	1,693	2,000	3,386	2,000	3,386
	250	1,000	2,000	2,000	4,000	2,000	4,000
	350	1,000	2,800	2,000	5,600	2,000	5,600
	500/600	1,000	4,000	2,000	8,000	2,000	8,000
	700	1,000	5,600	2,000	10,000 <sup>3</sup>	2,000	10,000 <sup>3</sup>
	750	1,000	6,000	2,000	10,000 <sup>3</sup>	2,000	10,000 <sup>3</sup>
	1,000/1,100	1,000	8,000	2,000	10,000 <sup>3</sup>	2,000	10,000 <sup>3</sup>
1,500	1,000	10,000 <sup>3</sup>	-	-	-	-	

<sup>3</sup> Limited by cable pulling and reel handling equipment.

**Table 11 Maximum Allowable Pulling Tensions for 1/C Copper P&L and PL&N Cables**

Cable Rating	Cable Size AWG or kcmil	Maximum Allowable Pulling Tension (lbs.)					
		1/C per Duct		2/C per Duct		3/C per Duct	
		Grip	Pulling Eye	Grip	Pulling Eye	Grip	Pulling Eye
1 kV	1/0	-	-	-	-	475	1,265
	250	-	-	-	-	677	3,000
	500	458	3,000	-	-	916	6,000
	750	571	4,500	-	-	1,141	9,000
	1,000	674	6,000	-	-	1,349	12,000
	1,500	897	9,000	-	-	-	-
5 kV	#4	-	-	415	501	415	501
	#2	-	-	460	796	460	796
	2/0	-	-	597	1,600	597	1,600
	250	-	-	725	3,000	725	3,000
	500	512	3,000	-	-	1,025	6,000
	750	631	4,500	-	-	1,262	9,000
15 kV	#4	-	-	653	653	653	653
	#2	-	-	693	796	693	796
	2/0	-	-	733	1,600	733	1,600
	250	-	-	916	3,000	916	3,000
	500	622	3,000	-	-	1,244	6,000
	750	750	4,500	-	-	1,498	9,000
	1,000	700	6,000	-	-	1,400	10,000 <sup>1</sup>
	1,500	857	9,000	-	-	-	-
25 kV	#2	-	-	-	-	800	1,060
	250	-	-	-	-	928	3,000
	500	-	-	-	-	1,181	10,000 <sup>1</sup>

<sup>1</sup> Limited by cable pulling and reel handling equipment.

Minimum Requirements for the Design and Installation of Electric Conduit, Insulated Cable, and Facilities

Maximum Allowable Pulling Tensions for Various Cable Rating, Sizes, and Configurations (continued)

Table 12 Maximum Allowable Pulling Tensions for 3/C Copper PL&N Cables, 1/C per Duct Revised

Cable Rating	Cable Size AWG or kcmil	Maximum Allowable Pulling Tension (lbs.)	
		Grip	Pulling Eye
5 kV	#2	464	1,194
	2/0	510	2,400
	250	657	4,500
	500	875	9,000
15 kV	#2	708	1,195
	2/0	840	2,400
	250	866	4,500
	500	1,150	9,000
	750	1,434	10,000 <sup>1</sup>

<sup>1</sup> Limited by cable-pulling and reel-handling equipment.

cited in Cal. Rest. Ass'n v. City of Berkeley  
No. 21-16278am archived December 27, 2023

**Minimum Requirements for the Design and Installation of Electric Conduit, Insulated Cable, and Facilities**

*The Information on This Page is “For Reference Only”*

**Table 13 Percent Fill for Common Cable/Conduit (DB 120) Combinations**

	Type of Cable	2"	3"	4"	5"	6"
600 V	1/0 Triplex	15%	7%	-	-	-
	4/0 Triplex	24%	11%	-	-	-
	350 kcmil Triplex	-	18%	11%	-	-
	750 kcmil Triplex	-	32% <sup>1</sup>	19%	13%	9%
	1,000 kcmil Triplex	-	-	25%	17%	-
	1/0 Quadruplex	20%	9%	-	-	-
	4/0 Quadruplex	-	15%	9%	-	-
	350 kcmil Quadruplex	-	24%	15%	10%	-
	750 kcmil Quadruplex	-	-	27%	18%	13%
	1,000 kcmil Quadruplex	-	-	35%	24%	16%
15 kV	3-#2 AWG, Cu-EPR	-	21%	13%	-	-
	3-350 kcmil, Cu-EPR	-	-	26%	17%	12%
	3-500 kcmil, Cu-EPR	-	-	31%	20%	14%
	3-750 kcmil, Cu-EPR	-	-	42%	28%	19%
	3-1,100 kcmil, Cu-EPR	-	-	-	38%	26%
25 kV	1-1/0, AI-EPR	32%	-	-	-	-
	3-1/0, AI-EPR	-	-	27%	-	-
	3-600 kcmil, AI-EPR	-	-	-	38%	26%
	3-1,100 kcmil, AI-EPR	-	-	-	47%	34%
	3-1,100 kcmil, Cu-EPR	-	-	-	48%	34%

<sup>1</sup> Although percent fill is less than 75%, it is difficult to pull 750 kcmil triplex in existing 3" conduit. It is acceptable to pull 750 kcmil triplex in existing 3" conduit. New construction should use 4" conduit.

*cited in Cal. Rest. Ass'n v. City of Berkeley  
No. 21-16278-AM archived December 27, 2023*

**Revision Notes**

Revision 15 has the following changes:

1. Modify Note 1 and Note 4 on Page 1.
2. Added new Note 6 on Page 1.
3. Added Trench requirements to this document on Page 3 and Page 4. Some of these trench requirements were previously listed in document 062288.
4. Added size 1100 cable to Note 14 on Page 7.
5. Re-arranged conduit and substructure installation section to top of Page 9.
6. Updated Note 5D under septic tank/leach field/leach line on Page 10.
7. Added new Figure 3 on Page 11.
8. Added requirements for steam lines on Page 12 and 13.
9. Modify Note 5 and added new Note 12 under material and equipment design and restriction on Page 14 and 16.
10. Revised Figure 10 on Page 17 to change 2W-2W switched switch with a 3W-3W switched switch.
11. Corrected weight cradled corrected factor formula on Page 20.



cited in Cal. Rest. Ass'n v. City of Berkeley  
No. 21-16278am archived December 27, 2023



**SERVICE ENTRANCE FROM UNDERGROUND VAULT USING BUS BARS**

**041352**

**Asset Type:** Electric Distribution      **Function:** Design and Construction  
**Issued by:** Mike Thibault (MLTC) *Mike Thibault*      **Date:** 11-01-18

**Rev. #02:** This document replaces Document 041352, Rev. #01. For a description of changes, see Page 2.

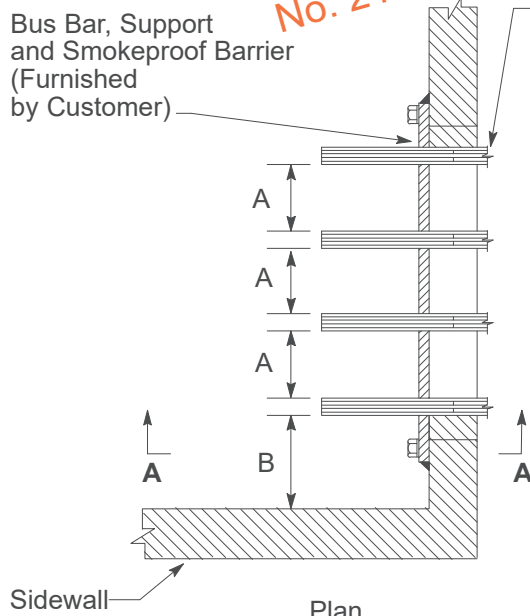
**Purpose and Scope:**

The purpose of this document is to illustrate the preferred method of installing a service entrance from an underground vault using bus bars.

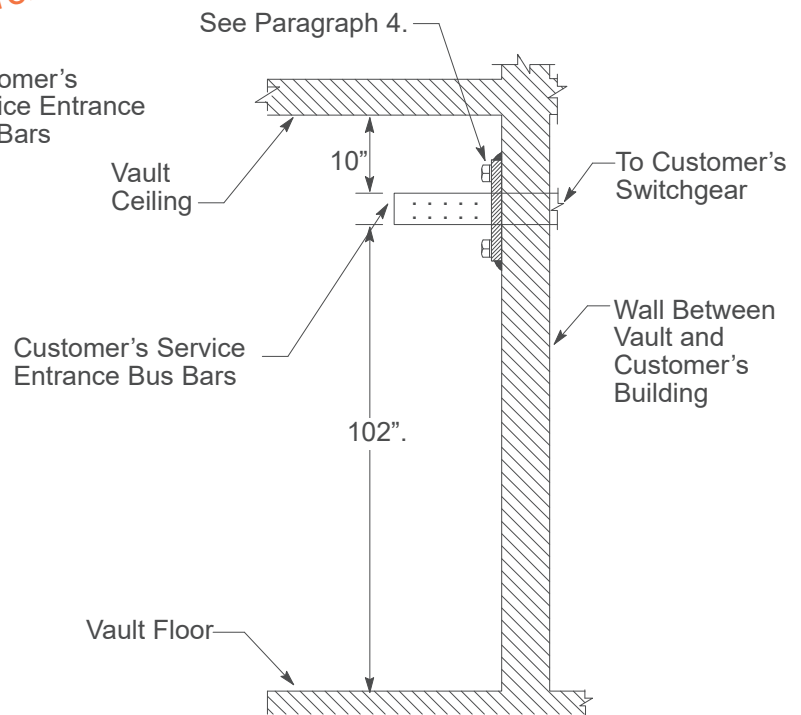
**General Information:**

1. Customer shall drill bus bars to fit connectors furnished by PG&E.
2. If the above configuration or dimensions illustrated in this document are impracticable because of physical or other limitations, consult PG&E.
3. For customer-owned underground vaults, consult PG&E.
4. All exposed grounded metal bolts within 10" of bus bars shall be suitably insulated.
5. For bus rated at less than 3,000 Amps, bus bars may extend less than 12" from bus support and smokeproof barrier. Consult PG&E.
6. Barrier not needed if firestop supports the bus and is smokeproof.

*cited in Cal. Rest. Ass'n v. City of Berkeley  
 No. 21-16278am archived December 27, 2023*

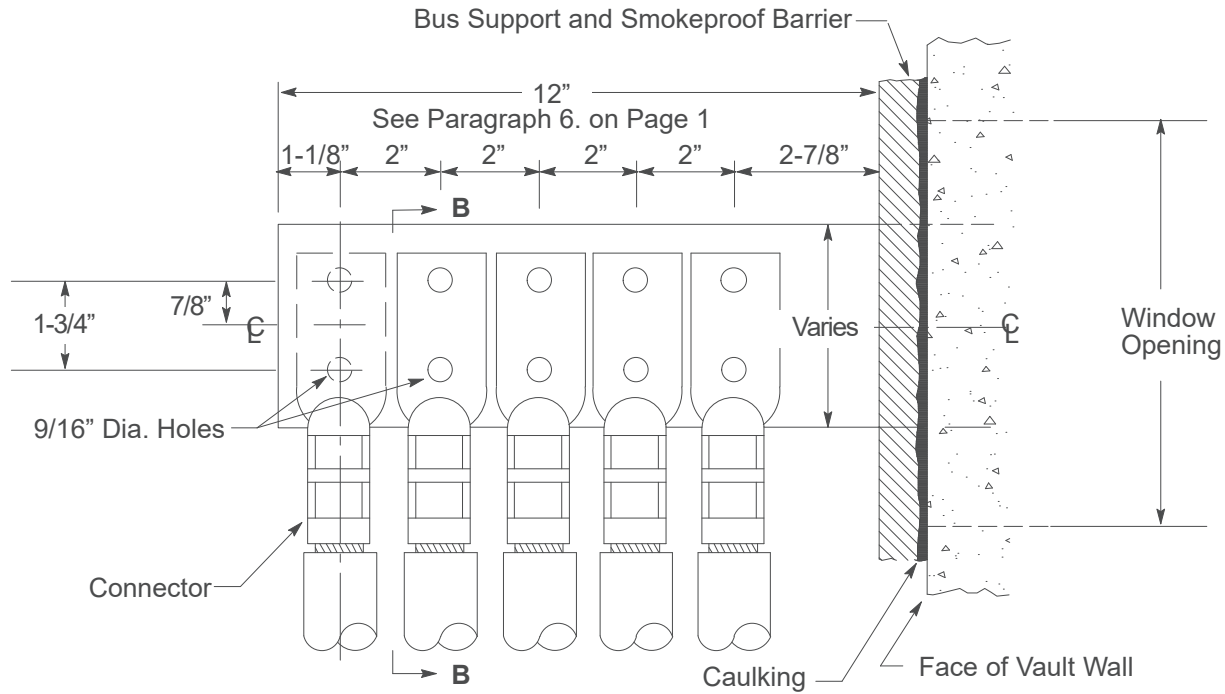


**Figure 1  
 Service Entrance**

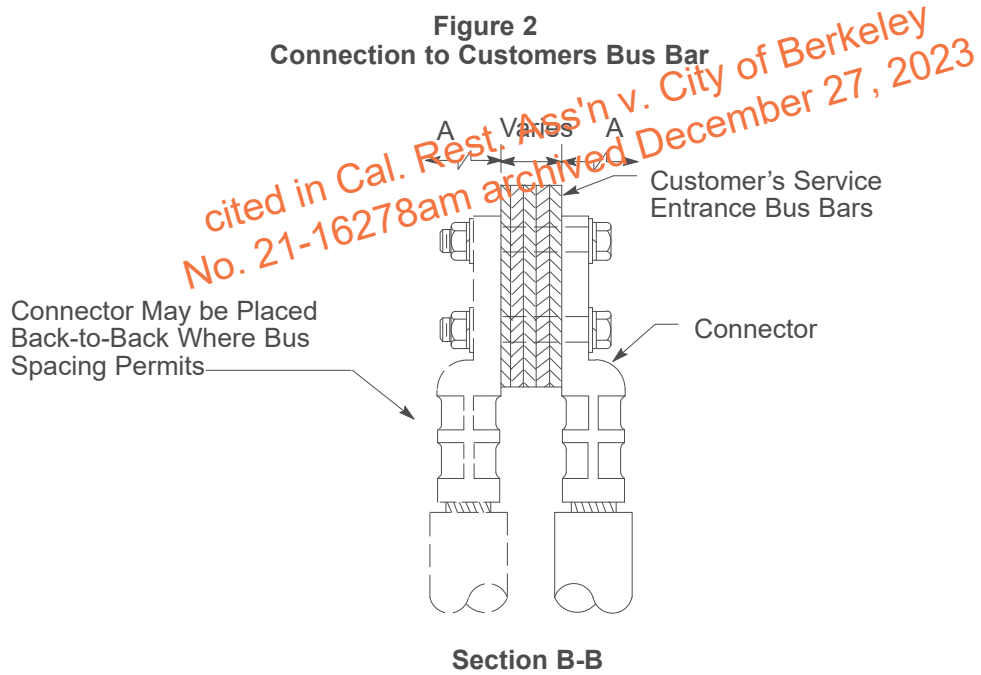


**Section A-A**

### Service Entrance From Underground Vault Using Bus Bars



**Figure 2**  
**Connection to Customers Bus Bar**



**Section B-B**



This document is also seen in Section 15 of the Electric and Gas Service Requirements ("Green Book") and in Section 13 of the Electric Meterman's Manual.

**Revision Notes:**

Revision 02 has the following changes:

1. Revised Section A-A on Page 1 to conform to Drawing 057521, Detail G.
2. Removed Table 1 on Page 2.

Prepared by: ABB1

	<b>CONCRETE PAD FOR THREE-PHASE, LOOP-STYLE, PAD-MOUNTED TRANSFORMERS</b>	<b>045292</b>
<b>Asset Type:</b> Electric Distribution		<b>Function:</b> Design
<b>Issued by:</b> Michael Thibault (MLTC)		<b>Date:</b> 12-01-19
<b>Rev. #13:</b> This document replaces PG&E Document 045292, Rev. #12. For a description of the changes, see Page 8.		

**This document is also included in the following manual:**

- [Electric and Gas Service Requirements Manual](#) (Greenbook)

**Purpose and Scope**

This document shows construction details for concrete pads for three-phase, loop-style, pad-mounted transformers. Refer to [Document 043817](#) for installation details of three-phase, radial-style, pad-mounted transformers. See [Document 045290](#) and [Document 045291](#) for fabrication and installation details of three-phase, loop-style, pad-mounted transformers.

**General Information**

1. When a pad is installed by the customer, that customer shall provide all materials. In areas of known unusually soft soil conditions, PG&E will require special treatment as specified in Notes 13, 14, and 15. Before pouring or setting the pad, the customer or contractor will request an inspection by PG&E to approve the installation. PG&E shall determine the acceptability of each pad installation.
2. The installation of the pad includes the two ground rods and the interconnecting ground wire.

**Application**

3. If a pad-mounted transformer cannot be located away from vehicular traffic, the customer shall provide suitable barriers for the protection of the transformer. PG&E shall determine the protection requirements according to [Document 051122](#).
4. If the customer is to use bus duct, the secondary opening is not needed. Grout in the window of precast pads.
5. The pad sizes are based on maximum dimensions, including cooling radiators, of the various manufacturers' transformers.
6. The Style IIE transformers will fit on Style IIB/IIC/IIF pads. The 75 kVA, Style IIE transformer will fit on the largest Style IIE pad. The 300 kVA, Style IIE transformer will fit on the small Style IIE pad. The 2,500 kVA, Style IIE transformer will sit on the old 80" x 106" pad, but the radiators will overhang the pad. (Note: Some 1989 and 1999 Style IIE transformers have radiators that will overhang the pad.)
7. The Style IIG will fit on the largest IIE pad.
8. The Style IIH will fit on the largest IIC/IIF pad.

**Construction Notes**

9. In general, all equipment pads should be installed as level as practical. Pads supporting oil-filled equipment must be leveled to within 1 inch in 8 feet in all directions.
10. An equipment pad SHALL NOT be placed on an elevated berm, mound or structure either earthen or otherwise when placed in a Flood Plain. If local knowledge of the area in which the equipment is to be placed identifies a high likelihood that uninsulated terminals of the equipment will come in contact with floodwater and the location cannot be moved to a location less likely to have flood levels come in contact with the exposed terminals, a Subsurface Fully Insulated Device should be installed in lieu of the pad mount design. In some cases such as transformers, because of capacity limits of subsurface material coded equipment it may not be possible to provide a transformer of sufficient capacity to serve loads in excess of the capabilities of a 1000 kVA UCD.
11. The transformer pad shall be placed on firm, compacted native material or on engineered fill which has been compacted at least to the requirements of Note 14.

**Concrete Pad for Three-Phase, Loop-Style,  
Pad-Mounted Transformers**

12. The area under the pad shall be excavated to the required grade, or to a depth necessary to reach firm, undisturbed material, whichever is deeper. The material can be considered firm if it cannot be penetrated by thumb except with moderate effort.
13. If firm material has not been reached within a depth of 3 feet, excavate 3 feet beyond the perimeter of the pad and backfill the entire excavated area to the required grade and to the requirements of Note 14.
14. In case it has been necessary to excavate deeper than the required grade to reach firm material, backfill to the required grade in one of the following ways:
  - A. Backfill with clean, non-expansive soil compacted to 90% of maximum density. Soil shall be placed in layers not more than 8 inches thick before compaction. Maximum density and in-place density is to be determined by [California Test Method No. 216-G, Part I and II](#) respectively, or by [ASTM D-1556](#) and [ASTM D-1557](#) respectively. A copy of the test results may be required by PG&E.
  - B. Backfill with soil-cement slurry consisting of one sack of Portland cement per cubic yard and clean native soil or sand. When slurry is used as a backfill material, the customer will not be required to use a poured-in-place pad.
15. In areas of known soft soil conditions, trenches within the pad excavation area for the installation of conduits shall be backfilled in one of the ways specified in Note 14 on Page 2.
16. In addition to the above, precast pads shall be placed on a 3-inch layer of slurry backfill or sand screeded level to provide uniform bearing.
17. Conduit windows shall be grouted with non-shrink grout (asphalt or blacktop is not approved for grouting).
18. Concrete shall be designed to attain a strength of 2,500 pounds per square inch (psi) at 28 days. Slump for concrete placement shall not exceed 3 inches. Reinforcing steel shall be per [ASTM A615](#), Grade 40 minimum.
19. A minimum distance of 6 feet shall be maintained between ground rods.
20. Wood-float or light broom finish the top of the slab. Finish all exposed edges with a finishing tool. Vertical edges shall have a 3/4-inch chamfer. Slope exposed horizontal surfaces slightly for drainage. Moist-cure concrete for at least 7 days after pouring. Do not install transformer until 14 days after pouring concrete. See Note 21 for exceptions to this requirement.
21. The transformer may be installed earlier than the 14 days specified above, provided the concrete has attained a compressive strength of at least 1,500 psi, obtained as follows (this procedure is permitted only for urgent cases where earlier pouring of pad is not practical):
  - A. For a six-sack mix using normal Portland cement, the transformer may be installed after 7 days; or for a six-sack mix using high early-strength cement, the transformer may be installed after 72 hours.
  - B. All concrete must be moist-cured to the minimum period specified above before installing the transformer.
  - C. Verify the required strength by either concrete cylinder test or Schmidt hammer test.
22. Belled ends of conduits should be placed approximately 1 inch above the concrete pad surface. If belled ends are removed, install end bell fittings. Temporarily plug or cap all conduits.
23. Only PG&E-approved utility electric-service-related equipment and structures may be installed in the area beneath the transformer pad. The area 6 feet deep and 12 inches horizontally around the pad shall be free of all foreign substructures.

**Construction Notes for Precast Pads**

24. Concrete shall be designed to attain a strength of 2,500 psi in 28 days.
25. Inserts and securing of inserts shall be of sufficient strength to lift the pad. A minimum of three inserts with 7/8-inch diameter, UNC thread and 2-1/4 inch inside depth, steel, galvanized with temporary plugs shall be provided.
26. Inserts shall be installed flush with the surface of the pad.
27. Reinforcing bars shall be as per [ASTM A615](#), Grade 40 minimum.
28. All exposed edges shall have a 3/4-inch chamfer or radius.
29. Surface shall have a light broom or wood-float finish.
30. The surface of the pad shall be level and flat.
31. Precast pads shall be permanently identified with manufacturer's name (for location see Figure 4 and Figure 5 on Pages 7 and 8) and have the weight stenciled on top of the pad.

**Concrete Pad for Three-Phase, Loop-Style,  
Pad-Mounted Transformers**

References	Location	Document
<u>Corrosion Resistant Ground Rods and Ground Rod Clamps</u> .....	<u>UG-1: Connectors/Greenbook</u> .....	<u>013109</u>
<u>Installation of Three-Phase, Radial-Style, Pad-Mounted Transformers</u> .....	<u>UG-1: Transformers</u> .....	<u>043817</u>
<u>Loop-Style, Three-Phase, Pad Mounted Transformers</u> .....	<u>UG-1: Transformers</u> .....	<u>045290</u>
<u>Installation of Loop-Style, Three-Phase, Pad-Mounted Transformers</u> .....	<u>UG-1:Transformers</u> .....	<u>045291</u>
<u>Location, Clearances, and Mechanical Protection Details for Pad-Mounted and Subsurface Equipment</u> .....	<u>UG-1: General</u> .....	<u>051122</u>
<u>Underground Conduits</u> .....	<u>UG-1: Conduits</u> .....	<u>062288</u>

*cited in Cal. Rest. Ass'n v. City of Berkeley  
No. 21-16278am archived December 27, 2023*

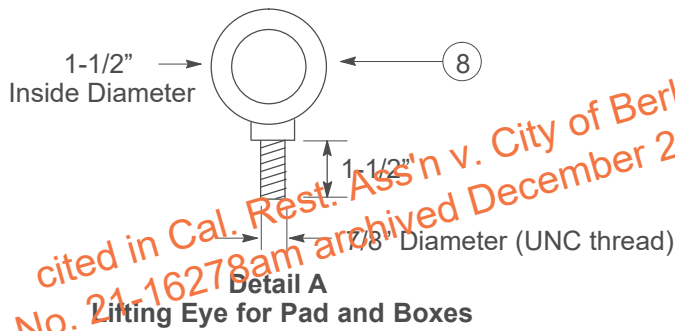
### Concrete Pad for Three-Phase, Loop-Style, Pad-Mounted Transformers

**Table 1 Bill of Materials for Concrete Transformer Pads**

Item	Quantity	Description	Code	Document
1	1	Pad, Concrete, Reinforced (see Page 5)	-	-
2	As Required	Wire, #2 AWG, Solid, Soft Drawn, Bare Copper <sup>1</sup>	290074	-
3	2	Ground Rod, 5/8" x 8', Copperclad	187013	<a href="#">013109</a>
4	2	Clamp, Ground Rod, for Item 3	187012	
5	As Required	Conduit, Type and Size (as required)	-	<a href="#">062288</a>
6	As Required	Reinforcing Steel, Number 4 <sup>2</sup>	-	-
7	As Required	Compacted Backfill	-	-
8	Tool	Bolt, Eye, 7/8" Diameter x 1-1/2" Long, 1-1/2" Inside Diameter, Shoulder-Type	190013	-

<sup>1</sup> When pad is installed for PG&E by others, the use of solid or stranded wire is acceptable.

<sup>2</sup> Number 3 rebar at 12-inch maximum separation with 4x4 6-6 wire mesh over the entire surface may be substituted for the use of Number 4 rebar.

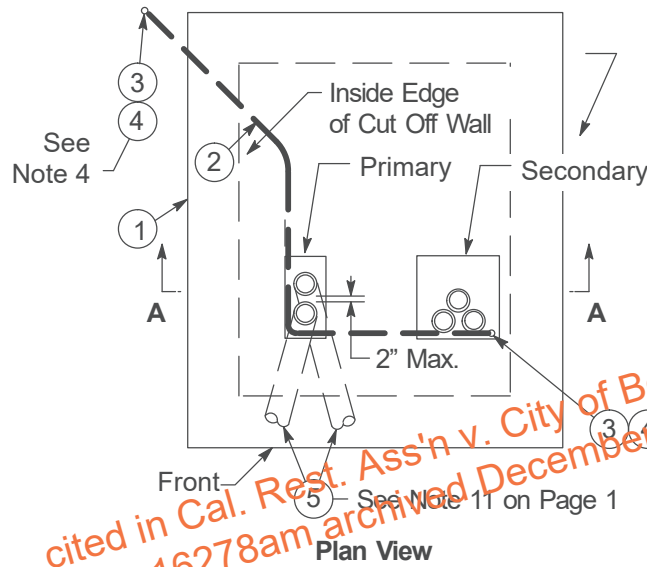


### Concrete Pad for Three-Phase, Loop-Style, Pad-Mounted Transformers

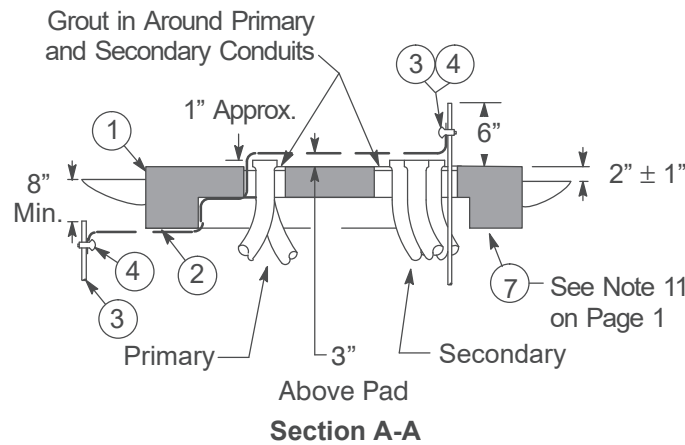
#### Pad Arrangements for Style IIA, IIB, IIC, IIF, and IIH Transformers

**Notes**

1. Primary conduits must be centered in the window.
2. Secondary conduits shall be grouped towards the front of the pad.
3. Precast pads do not have cut off walls.
4. A 6-foot minimum separation shall be maintained between ground rods.
5. The ground wire must be a continuous wire that runs from the outside ground rod, under the pad, to the primary window, then above the pad from the primary window, through the secondary window, to the secondary ground rod as shown below.



*cited in Cal. Rest. Ass'n v. City of Berkeley  
No. 21-16278am archived December 27, 2023*



**Figure 1**  
Style IIA, IIB, IIC, IIF, and IIH Pad Arrangement,  
Poured-in-Place Pad Shown

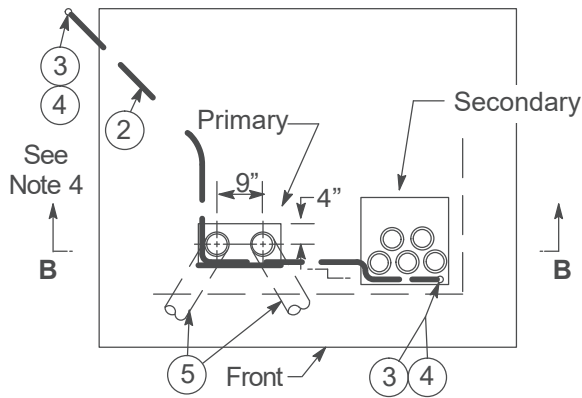


### Concrete Pad for Three-Phase, Loop-Style, Pad-Mounted Transformers

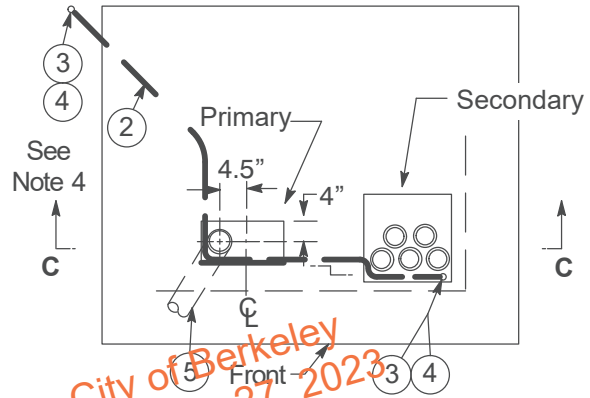
#### Pad Arrangements for Style IID, IIE, and IIG Transformers

##### Notes

1. Install primary conduits as shown. Keep single primary conduit installation to the left as indicated to reduce strain on elbow terminators.
2. Secondary conduits shall be grouped towards the front of the pad.
3. Precast pads do not have cut off walls.
4. A 6-foot minimum separation shall be maintained between ground rods.
5. The ground wire must be a continuous wire that runs from the outside ground rod, under the pad, to the primary window, then above the pad from the primary window, through the secondary window, to the secondary ground rod as shown below.

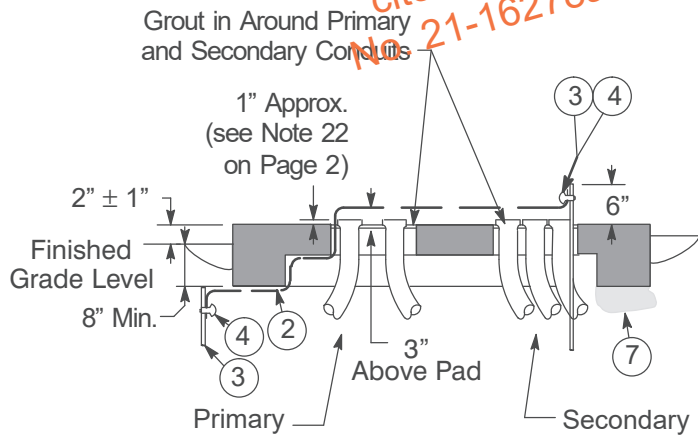


Plan View

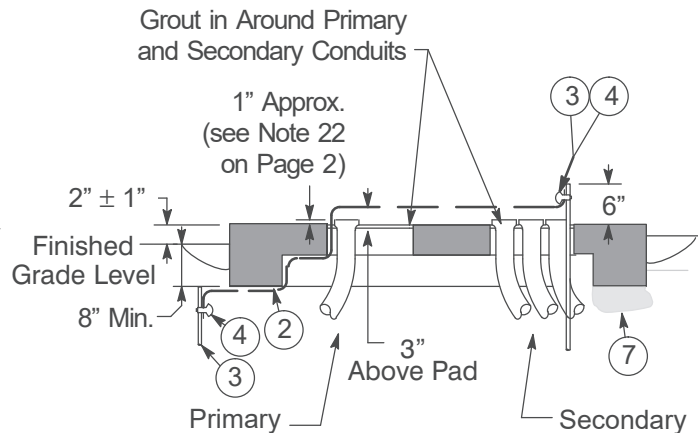


Plan View

*cited in Cal. Rest. Ass'n v. City of Berkeley  
No. 21-16278am archived December 27, 2023*



Section B-B



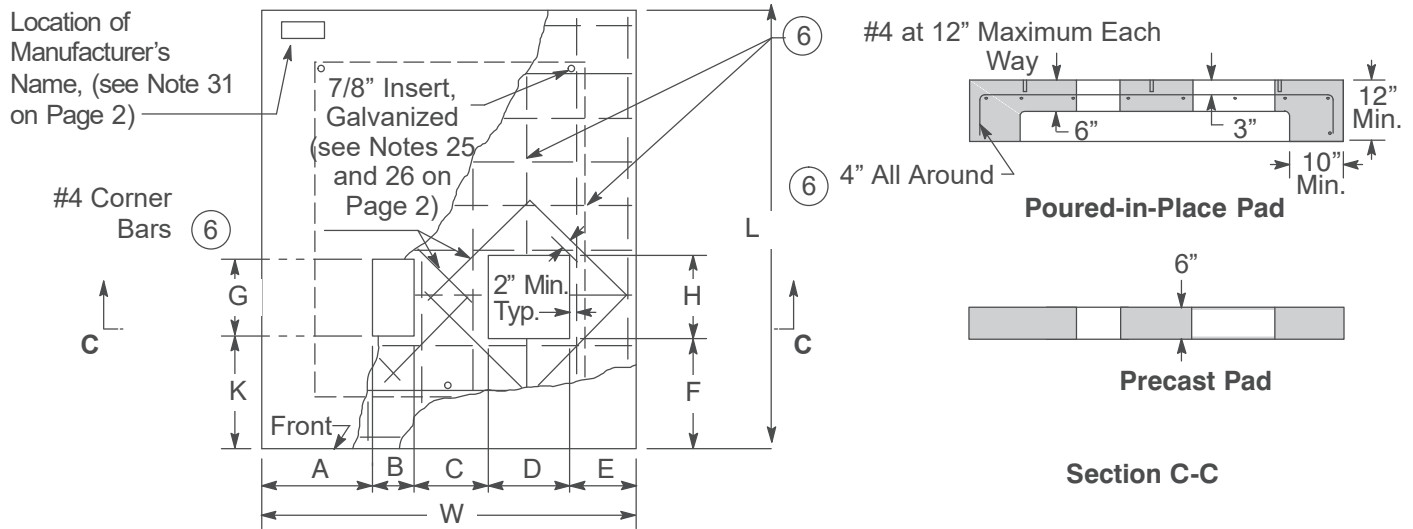
Section C-C

**Figure 2**  
Loop Installation of Style IID, IIE, and IIG Pad  
Arrangement, Poured-in-Place Pad Shown

**Figure 3**  
Radial Installation of Style IID, IIE, and IIG Pad  
Arrangement, Poured-in-Place Pad Shown

**Concrete Pad for Three-Phase, Loop-Style,  
Pad-Mounted Transformers**

**Concrete Pad Details for Style IIA, IIB, IIC, IIF, and IIH Transformers**



**Figure 4**  
**Construction Details of Style II A/B/C/F/H Pad**  
(see Figure 1 on Page 5 for pad arrangement)

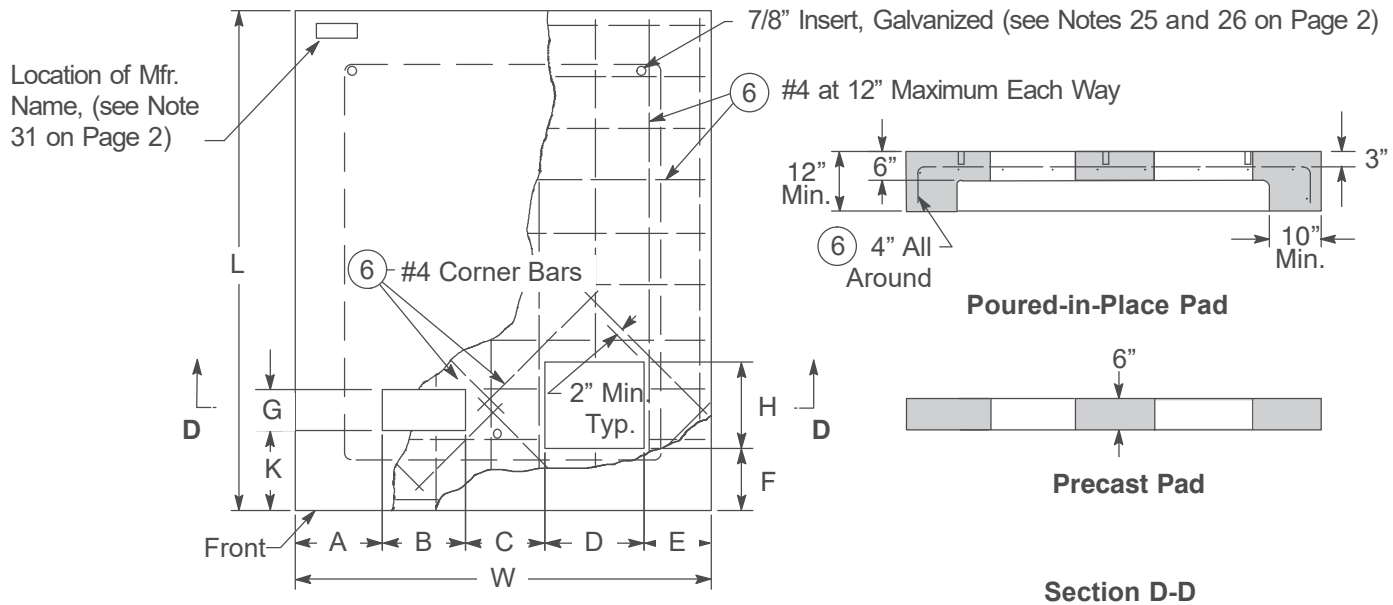
**Table 2 Dimensions and Codes for Style IIA, IIB, IIC, IIF, and IIH Transformer Pads<sup>1</sup>**

Transformer			Pad Dimensions (inches)											Code
Style	kVA Size	Approximate Maximum Weight (lbs)	A	B	C	D	E	F	G	H	K	L	W	
IIA	75	3,200	21	8	14	16	13	15	16	16	15	72	72	043436
	(112.5) <sup>2</sup>	3,200												
	150	3,500												
	(225) <sup>2</sup>	4,000												
IIB and IIF	300	4,500	23	8	19	17	13	15	16	19	15	78	80	043538
	(225) <sup>2</sup>	4,500												
	300	5,000												
	(500) <sup>2</sup>	6,000												
	750	9,000												
IIC and IIF	1,000	11,000	32	8	23	17	23	15	16	19	15	112	98	040243
	1,500	13,000												
IIC and IIF	(2,000) <sup>2</sup>	15,000	31	8	23	17	26	15	16	19	15	120	105	040245
	2,500	16,000												
IIH	2955/ 3325	22,000												

<sup>1</sup> See [Document 066211](#) for approved suppliers.  
<sup>2</sup> ( ) = Indicates a kVA size that is no longer purchased.

### Concrete Pad for Three-Phase, Loop-Style, Pad-Mounted Transformers

#### Concrete Pad Details for Style IID, IIE, and IIG Transformers



**Figure 5**  
Construction Details of Style IID, IIE, IIG Pad  
(see Figure 2 on Page 6 for pad arrangement)

**Table 3** Dimensions and Codes for Style IID, IIE, and IIG Transformer Pads<sup>1</sup>

Style	Transformer kVA Size	Approximate Maximum Weight (lbs)	Pad Dimensions (inches)										Code	
			A	B	C	D	E	F	G	H	K	L		W
IID and IIE	75	4,600	17	16	15	19	13	10	6	17	14	61	80	040291
	(112.5) <sup>2</sup>	4,800												
	150	5,000												
IIE	(225) <sup>2</sup>	5,500	22	16	15	20	17	20	6	19	25	106	90	040292
	300	5,800												
	(500) <sup>2</sup>	6,100												
	750	9,000												
IIE	1,000	11,000	22	16	15	20	17	20	6	19	25	106	90	040292
	1,500	13,000												
IIE	2,500	16,000	22	16	15	20	17	20	6	19	25	106	90	040292
IIG	2955/3325	22,000	22	16	15	20	17	20	6	19	25	106	90	040292

<sup>1</sup> See [Document 066211](#) for approved suppliers.



<sup>2</sup> ( ) = Indicates a kVA size that is no longer purchased.

#### Revision Notes

Revision 13 has the following changes:

1. Add Note 10 on Page 1.

Prepared by: MZGD

	<b>CLEARANCES AND LOCATION REQUIREMENTS FOR ENCLOSURES, PADS, AND UNDERGROUND EQUIPMENT</b>		<b>051122</b>
	<b>Asset Type:</b> Electric Distribution	<b>Function:</b> Design	
<b>Issued by:</b> M. L. Thibault (MLTC) 	<b>Date:</b> 03-25-22		
<b>Rev. #22:</b> This document replaces PG&E Document 051122, Rev. #21 For a description of the changes, see Page 28.			

This document is also included in the following manual:

- [Electric and Gas Service Requirements Manual](#) (Greenbook)

### Purpose and Scope

This document contains information relating to the placement of electric underground equipment and enclosures. This includes pad-mount, subsurface, and vault installations with or without equipment.

References	Location	Document
<a href="#">Marking, Numbering, and Identification of Line Structures</a> .....	OH: Marking .....	<a href="#">022168</a>
<a href="#">Concrete Pad for Three-Phase, Loop-Style, Pad-Mounted Transformers</a> .....	UG-1: Transformers/Greenbook .....	<a href="#">045292</a>
<a href="#">Pad-Mounted, Load-Break Switches and Fuses</a> .....	UG-1: Ditches .....	<a href="#">053318</a>
<a href="#">Pad-Mounted Transformers Installed Indoors</a> .....	UG-1: Transformers/Greenbook .....	<a href="#">057521</a>
<a href="#">Landscape Screen for Pad-Mounted Transformers</a> .....	UG-1: Transformers/Greenbook .....	<a href="#">063422</a>
<a href="#">Box-Pad for Pad-Mounted Transformers</a> .....	UG-1: Transformers/Greenbook .....	<a href="#">064309</a>
<a href="#">Pad-Mount Capacitor</a> .....	UG-1: General .....	<a href="#">066197</a>
<a href="#">PG&amp;E Approved Manufacturers</a> .....	Greenbook .....	<a href="#">066211</a>
<a href="#">Installation of Pad-Mounted, Load-Break Junction</a> .....	UG-1: Switches .....	<a href="#">066212</a>
<a href="#">General Order (G.O.) 128</a> .....	TIL .....	<a href="#">G.O. 128</a>

California Administrative Code:

[Title 8 – Industrial Relations, Chapter 4, Sub-Chapter 5, Electrical Safety Orders](#)

[Title 24 – State Building Standards, Part 3 – California Code of Regulations, California Electric Code](#)

## 1. Clearances

Clearances are divided into the following sections:

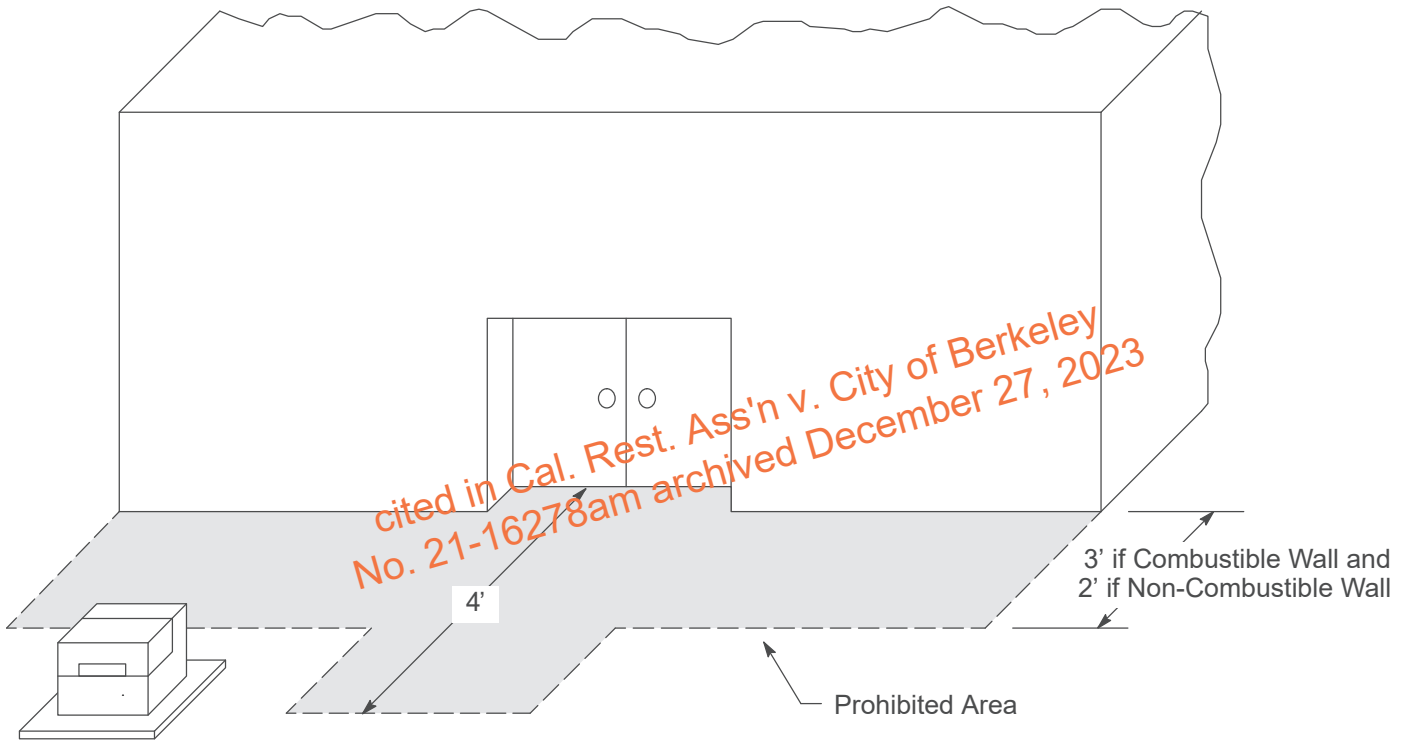
- Building clearances.
- Clearances to foreign substructure.
- Horizontal work space clearances.
- Hazardous locations.

Underground equipment, pads and enclosures shall be located so that they meet or exceed the required clearances in each of the clearances sections **and** in each of their subsections.

## Clearances and Location Requirements for Enclosures, Pads, and Underground Equipment

### 2. Building Clearances

- A. Clearances from building surfaces (see Figure 1): Oil filled pad-mount equipment shall have the following clearances (based on [G.O. 128. Rule 34.3 \[D\]](#)):
- a) 3-foot minimum from combustible building surfaces to the edge of the pad.
  - b) 2-foot minimum from non-combustible building surfaces to the edge of the pad. Non-combustible materials include brick, clay, concrete, steel, stone, and stucco.
- B. Doorway clearance (see Figure 1): Pad-mounted equipment shall not be placed where it impedes the flow of traffic through a doorway. In general, 4 feet of doorway clearance is sufficient (based on the [Uniform Building Code](#)).



**Figure 1**  
**Building and Doorway Clearances**  
(see Notes 2.A and 2.B)

## Clearances and Location Requirements for Enclosures, Pads, and Underground Equipment

### 2. Building Clearances (continued)

C. Vertical clearance from overhangs (see Figure 2): To provide space for hoisting equipment so that equipment can be replaced, the following vertical clearances from the top of the pad for pad-mounted equipment or top of the enclosure for subsurface equipment are required (based on [G.O. 128, Rules 17.3](#) and [34.2](#)).

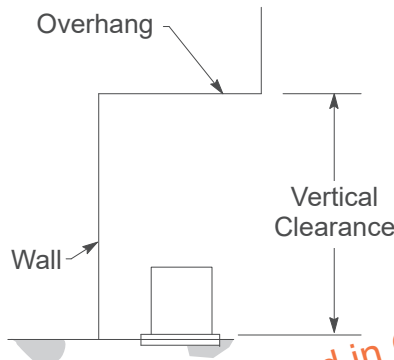
a) 20-foot minimum for:

- 1Ø pad-mount equipment.
- Subsurface equipment.
- Style MTP 3Ø transformer.

b) 30-foot minimum for:

- 3Ø pad-mount equipment except style MTP transformers.

c) When required for installations such as in dry vaults ([Document 057521](#)), the vertical clearance outside the doorway may be reduced to 10 feet from ground level. This reduced clearance will greatly expand the replacement time, since the equipment must be jacked and rolled out to a position where the clearance is adequate to hoist it.



**Figure 2**  
**Clearances for Pad-Mounted**  
**or Subsurface Equipment**  
**(see Note 2.C)**

*cited in Cal. Rest. Ass'n v. City of Berkeley  
No. 21-16278am archived December 27, 2023*

D. Railroad or streetcar track clearance: 6-foot minimum clearance is required from the rail to the nearest edge of any manhole, enclosure, or secondary box ([G.O. 128, Rule 31.5 \[D\]](#)).

### Clearances and Location Requirements for Enclosures, Pads, and Underground Equipment

#### 3. Clearances to Foreign Substructures

- A. Pad-Mounted Equipment:  
The area 1 foot around and 6 feet below the pad or pedestal shall be kept free of foreign substructures.
- B. Subsurface Equipment or Enclosures:  
The area 1 foot around and 6 feet below the enclosure shall be kept free of foreign substructures.

#### 4. Work Space Requirements

Maintain work space requirements as indicated on all new installations. Exercise judgement on existing installations where encroachment has occurred. For example, a fire hydrant located within the work space that does not adversely affect operations is not a concern. Clear and level work areas are required around underground equipment and enclosures to provide an adequate safe working space for operation or maintenance. Obstructions and elevation changes, other than a standard city/county street curb, are not allowed in the work space. (Based on [G.O. 128, Rule 17.3](#) and [34.2](#)).

- A. Primary enclosures (see Table 1 below and Figure 3 on Page 5): Sufficient clearance to remove covers, operate with hot sticks, replace equipment and cable, etc., is required. Field conditions and the specific equipment may allow some of the clearances to be reduced.

**Table 1 Primary Enclosure Clearances**

Primary Enclosures	Required Clearances
Round or Square 3' x 5' (interior dimensions)	3' From Outside Edges
4' x 6' 6" (interior dimensions)	3' From the Outside Edge of the Long Side / 4' From the Outside Edge of the Short Side
4' 6" x 8' 6" (interior dimensions)	3' From the Outside Edge of the Long Side / 5' From the Outside Edge of the Short Side
J-Box in 3' x 5'	3' on short sides, 2' on long side adjacent to the junction bars (the non-operable side), 5' on the long side opposite the junction bars (the operable side)
J-Box in 4' x 6' 6"	4' on short sides, 2' on long side adjacent to the junction bars (the non-operable side), 5' on the long side opposite the junction bars (the operable side)
J-Box in 4' 6" x 8' 6"	5' on short sides, 2' on long side adjacent to the junction bars (the non-operable side), 5' on the long side opposite the junction bars (the operable side)

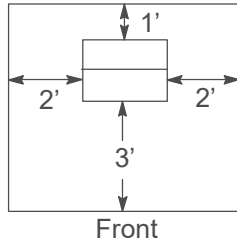
- B. Pad-Mounted Equipment (see Figure 4 and Figure 5 on Page 6).
  - a) 8'-foot minimum (measured from the edge of the pad) in front of all equipment doors to provide room to operate with hot sticks and to replace the equipment. Some equipment types have operable doors in both the front and the rear and both require 8 feet of operating room.
  - b) 5'-foot minimum on non-operable sides with control cabinet doors.
  - c) 3'-foot minimum from non-operable sides without control cabinet doors.  
Exceptions to the 3' minimum are:
    - (1) Landscaping obstructions (decorative walls, planters, rocks, etc.) that are up to about 1 foot wide and 2 feet tall may be placed next to the pad on non-operable sides (refer to [Document 063422](#)).
    - (2) One of the 3-foot dimensions may be reduced to 2 feet where Note 2.A.b on Page 2 applies, except for pad-mount switchgear.

### Clearances and Location Requirements for Enclosures, Pads, and Underground Equipment

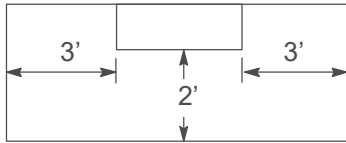
C. Secondary Enclosures – Minimum Work Space Required:

- a) Pedestal: 3 feet in front, 2 feet to the side, and 1 foot to the back.

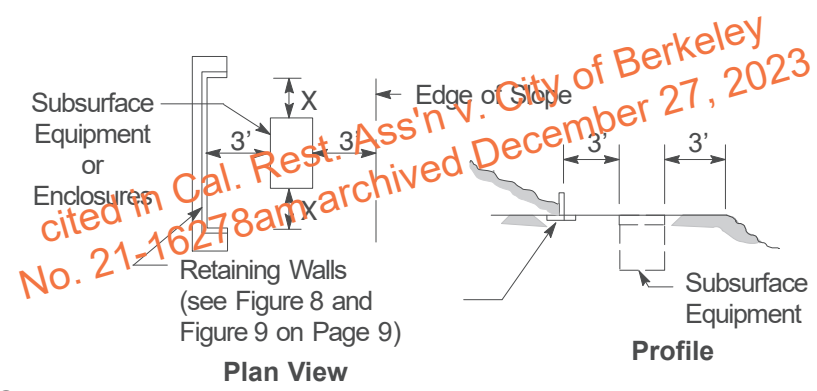
**4. Work Space Requirements (continued)**



- b) Secondary Splice Box – 24" x 36" or smaller: 3 feet on short sides, 2 feet on one long side.



- c) Secondary Splice Box – 3' x 5' or larger: Same as Table 2.



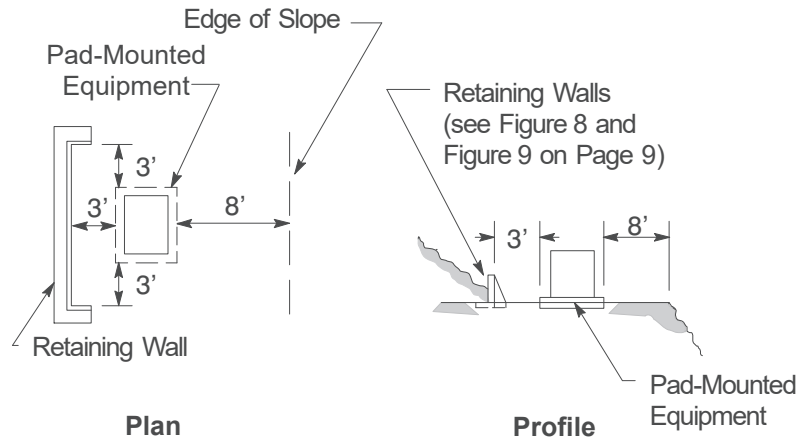
X = 3' for Round or Square  
 X = 3' for 3' x 5'  
 X = 5' for 4' 6" x 8' 6"

**Figure 3**  
**Example of Subsurface Equipment or Enclosures Installed on Sloped Terrain**  
 (see Note 4.A on Page 4)

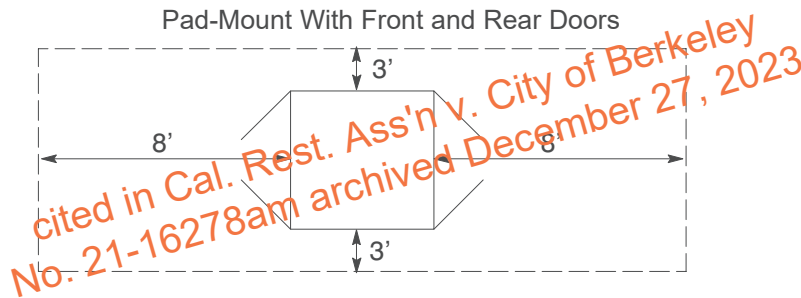


## Clearances and Location Requirements for Enclosures, Pads, and Underground Equipment

### 4. Work Space Requirements (continued)



**Figure 4**  
Example of Pad-Mounted Equipment (with front doors only) Installed on Sloped Terrain  
(see Note 4.B on Page 4)



**Figure 5**  
Work Space for Pad-Mounted Equipment  
(with front and rear doors including most switches and capacitors)  
(see Note 4.B on Page 4)

### 5. Hazardous Locations

Use the following guide when installing pad-mounted and subsurface equipment in areas where hazardous liquids and gases are dispensed or stored in sealed containers.

- A. Liquefied flammable gases: Do not install pad-mounted or subsurface equipment within 20 feet of a gas dispenser without conforming to the regulations concerning installation of electrical equipment in hazardous areas (refer to [Articles E500-1, E500-2, E500-3, E514-1, and E514-2 of Title 24, Part 3, State Building Standards](#)).  
Examples: Gas station fuel pump, convenience store propane pump.
- B. Any container which stores flammable liquid or gas: These containers will be considered equivalent to “combustible walls”. Therefore, the required clearances are the same as established in Note 2.A.a on Page 2 of this document. Examples: Emergency generator, propane tank at a house.

## Clearances and Location Requirements for Enclosures, Pads, and Underground Equipment

### 6. Spill Prevention Control and Countermeasure (SPCC) and Oil Containment

It is the customer's responsibility to comply with spill prevention and containment requirements for oil-filled electrical equipment in accordance with applicable laws, regulations, and ordinances. The [Spill Prevention Control and Countermeasure \(SPCC\)](#) regulations and the [Uniform Fire Code \(UFC\)](#) require the installation of containment structures to prevent spills and leaks of oil from reaching a waterway. SPCC requirements are found in the [Code of Federal Regulations, Title 40, Part 112](#) and apply to facilities having a total quantity of oil exceeding 1,320 gallons. The requirements of [UFC Articles 79](#) and [80](#) may also apply to containers and equipment holding more than 55 gallons of oil. These regulations include information on the type and size of the containment needed. Additional containment requirements may be mandated in local hazardous materials ordinances.

### 7. Future Construction

Consideration should be given not only to conditions existing at the time of installation but also to possible future structures and equipment that could interfere with required clearances or accessibility. On those installations where there is a high probability of a future obstruction, install a clearance requirement sign (Code 373998) on the equipment.

### 8. Noise Control

Transformer noise level increases with the kVA size. Avoid placing transformers alongside bedrooms and other places where noise may be objectionable.

### 9. Retaining Walls

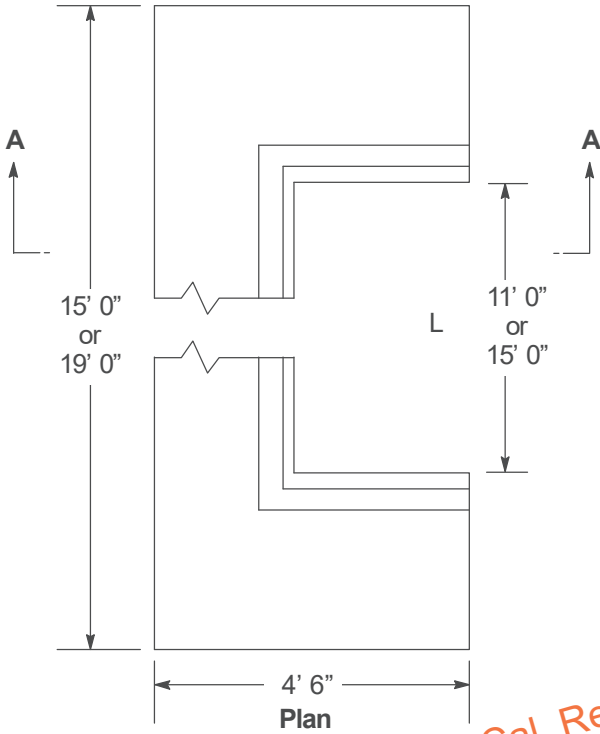
- A. Retaining walls are required when PG&E determines that it is necessary to protect equipment or enclosures against landslides, drainage wash, drifting sands, etc. The applicant is responsible for the installation and maintenance of the retaining walls and any associated safety rail. The retaining wall will be designed to provide a barrier of sufficient strength and suitable construction to provide adequate protection and working space around the enclosure or equipment. Typical examples of retaining wall placement are shown in Figure 3 and Figure 4 on Page 6 of this document.
- B. Pre-approved retaining wall designs and materials are shown on Pages 8 and 9 of this document.
- C. For retaining walls in excess of the dimensions shown on Page 8:
  - a) The wall will be constructed of precast concrete, concrete poured in place, or concrete block.
  - b) A safety rail of corrosion resistant material is required at the top of all retaining walls when wall height exceeds 4 feet (refer to [Utility Standard SAFE-1012S](#) for more information).
  - c) The applicant will provide PG&E with a set of design drawings and structural calculations certified by a licensed civil engineer.
- D. Treated redwood or pressure-treated Douglas fir posts (nominal 4" x 4" minimum) and planks (nominal 2 inches or thicker) may be used for short (1 foot or less) retaining walls. Posts should be 24 inches or less in length and extend at least 12 inches below ground and not more than 12 inches above ground (see Page 9).
- E. The working area within the retaining wall shall be level.
  - a) For pad-mounted equipment, it is to be slightly below the pad level (see the appropriate pad document for specific information).
  - b) For subsurface enclosures, it is to be level with the enclosure.
- F. The working area shall be kept weed free and covered with a locally acceptable decorative covering.

## Clearances and Location Requirements for Enclosures, Pads, and Underground Equipment

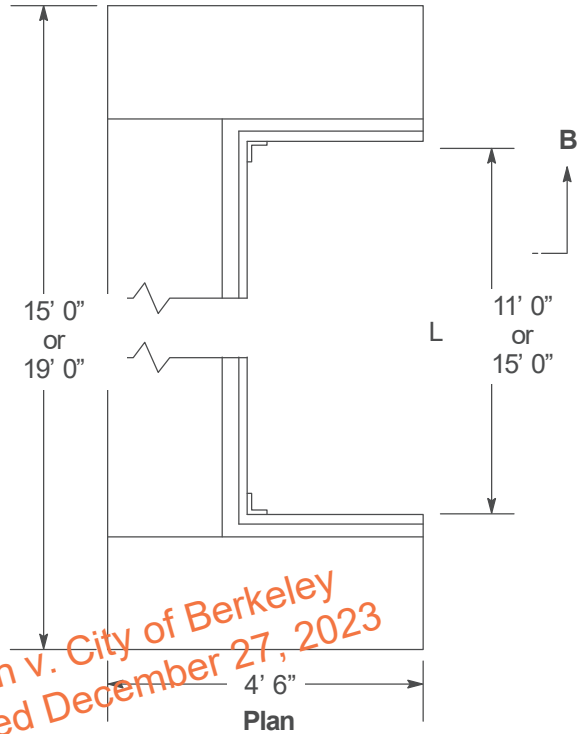
### 10. Precast Retaining Walls

**Note**

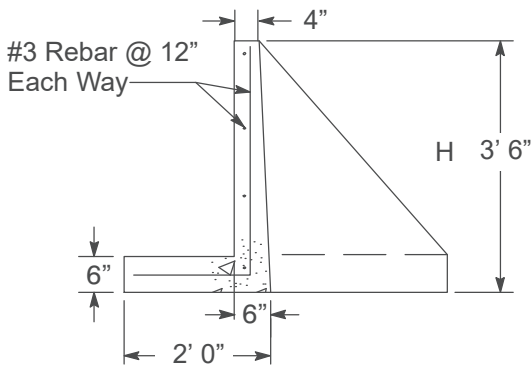
1. For drainage requirements, see Figure 9 on Page 9.



**Figure 6**  
Concrete Poured in Place or Concrete Block Retaining Wall

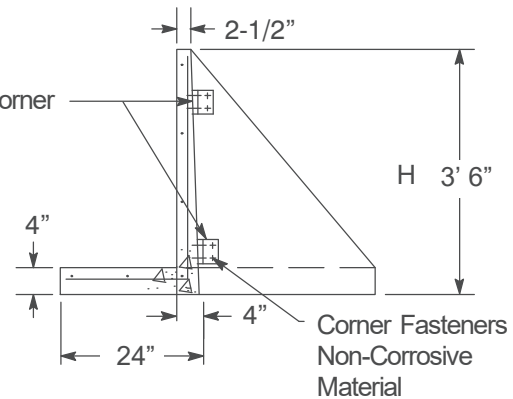


**Figure 7**  
Precast Concrete Retaining Wall  
(see Table 2 on Page 8)

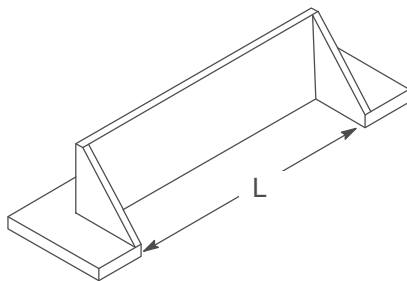


**Section A-A**

2 Angles  
3" x 3" x 1/2" x 4"  
Galvanized Each Corner



**Section B-B**



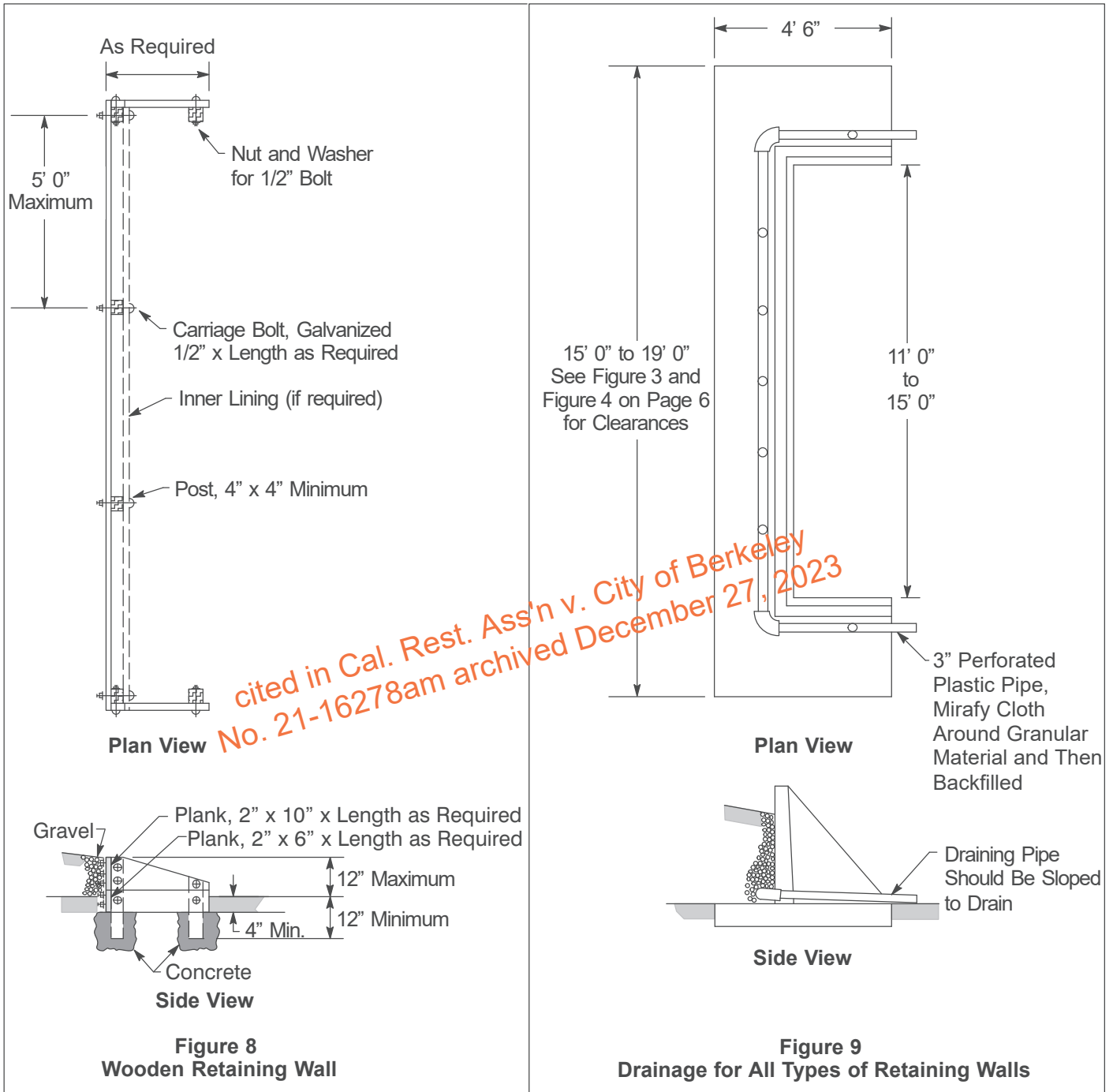
**Table 2 Codes for Precast Retaining Walls**

Dimension		Code <sup>1</sup>
L	H	
11' 0"	3' 6"	024881
15' 0"		024882

<sup>1</sup> See [Document 066211](#) for approved suppliers.

**Clearances and Location Requirements for Enclosures, Pads, and Underground Equipment**

**11. Wooden Retaining Walls and Drainage Details for All Retaining Walls**



## Clearances and Location Requirements for Enclosures, Pads, and Underground Equipment

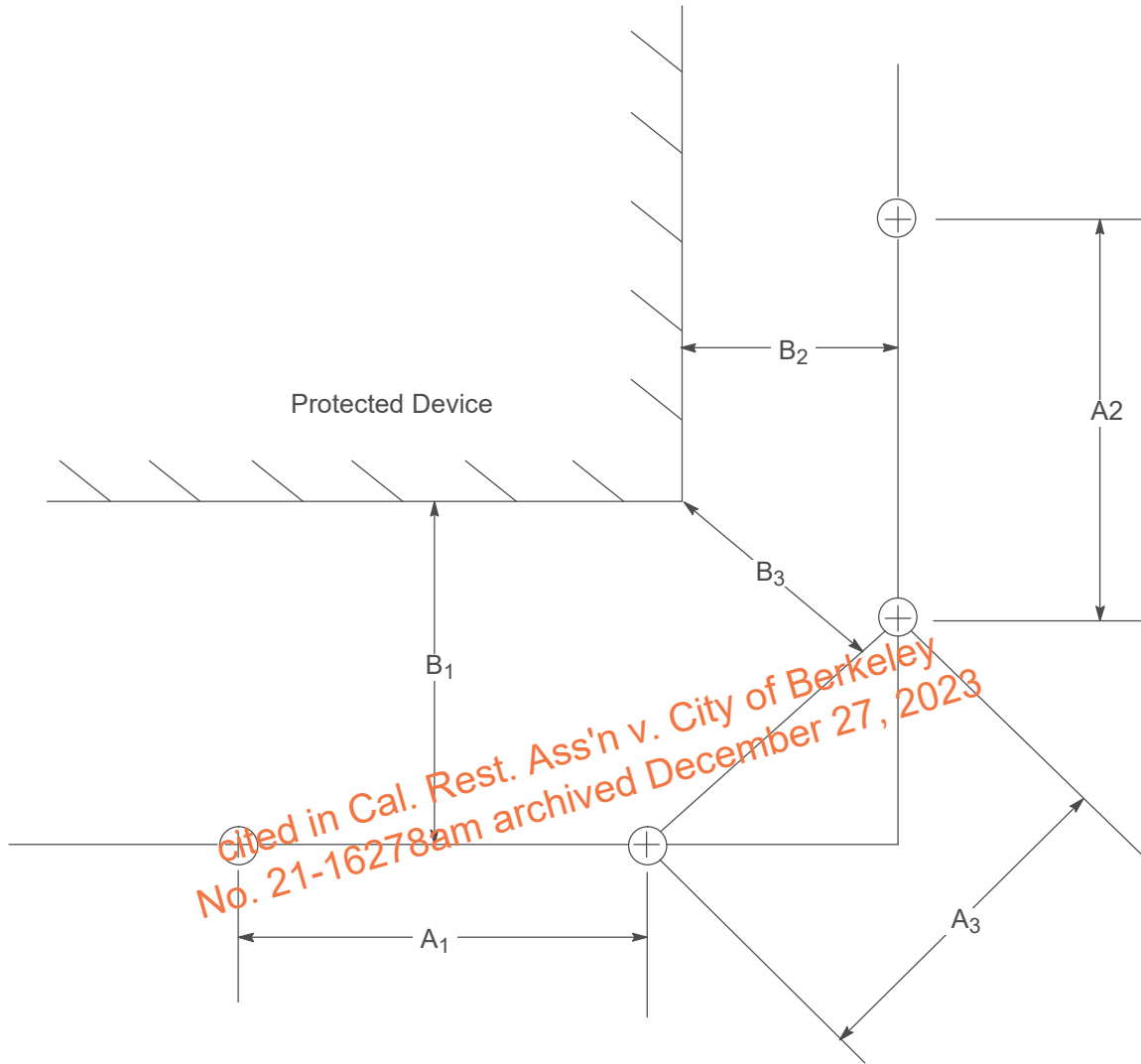
### 12. Barrier Posts

- A. Barrier Posts must be installed such that **ANY** equipment that contains control cabinets can be fully opened and the doors of the control cabinets locked in an open position. Reference Note 4.B.b for clarification. Examples of this requirement may be interrupters with SCADA cabinets installed. Reference [Document 076260](#) Multi-way Interrupter and Single-way Pad-Mount Interrupters in [Document 068188](#).
- B. Physical protection from vehicular traffic shall be provided in accordance with the level of vehicular exposure. Barrier posts, etc., are intended to provide reasonable warning from accidental vehicular contact, rather than to prevent all possible contact. When PG&E determines it necessary, the applicant will provide acceptable physical protection.
- C. In general, pad-mounted equipment having the following setbacks do not require the customer to provide any other physical protection.
- a) Single-family, duplex, and other low density residential areas: 3-foot minimum from the edge of the thoroughfare pavement due to low vehicular traffic (see [G.O. 128, Rule 23.6](#) for definition of thoroughfare).
  - b) Commercial, apartment, condominium, and other high density areas: 9 feet from the edge of the thoroughfare pavement due to high vehicular traffic and frequent truck-backing.
- The design of the particular layout may, of course, call for an increase or decrease in these dimensions. For example, a 3-foot setback is often adequate for parts of commercial parking lots where traffic flow is constrained and backing perpendicular to the curb is unlikely.
- D. The posts shown in this document are the standard means for providing such physical protection. Suitable alternatives to these protective posts may be proposed by the applicant for PG&E's approval.
- E. All barrier posts at the same installation site will be the same height.
- F. A building wall can be considered as physical protection provided it is located at a point where a post would be normally required.
- G. Maintain 36" minimum clearance between barrier posts and the edge of the pad in front of the equipment doors so that they do not interfere with opening the doors.
- H. Certain types of pad-mounted equipment have doors in both front and back and require 36" minimum clearance to the pad on both sides.
- I. Use removable posts when
- a) Posts are installed less than 8 feet in front of the equipment's doors, or
  - b) Where fixed posts would obstruct access for installation or replacement of equipment.
- J. Preferred barrier post arrangements for specific equipment are provided in Figure 11 on Page 12 to Figure 23 on Page 24. These may be modified as needed, to meet specific layouts, but must conform to the requirements in Figure 10 on Page 11.
- K. Barrier post details are shown in Figure 24 on Page 25 to Figure 30 on Page 27.

cited in Cal. Post Ass'n v. City of Berkeley  
No. 21-16278an archived December 27, 2023

**Clearances and Location Requirements for Enclosures, Pads, and Underground Equipment**

**12. Barrier Posts (continued)**



*Cited in Cal. Rest. Ass'n v. City of Berkeley  
 No. 21-16278am archived December 27, 2023*

A = Distance Between Posts in Inches  
 B = Shortest Distance Between the Protected Device and the Line Between Barrier Posts

**Figure 10  
 Generic Barrier Post Placement**

**Requirements**

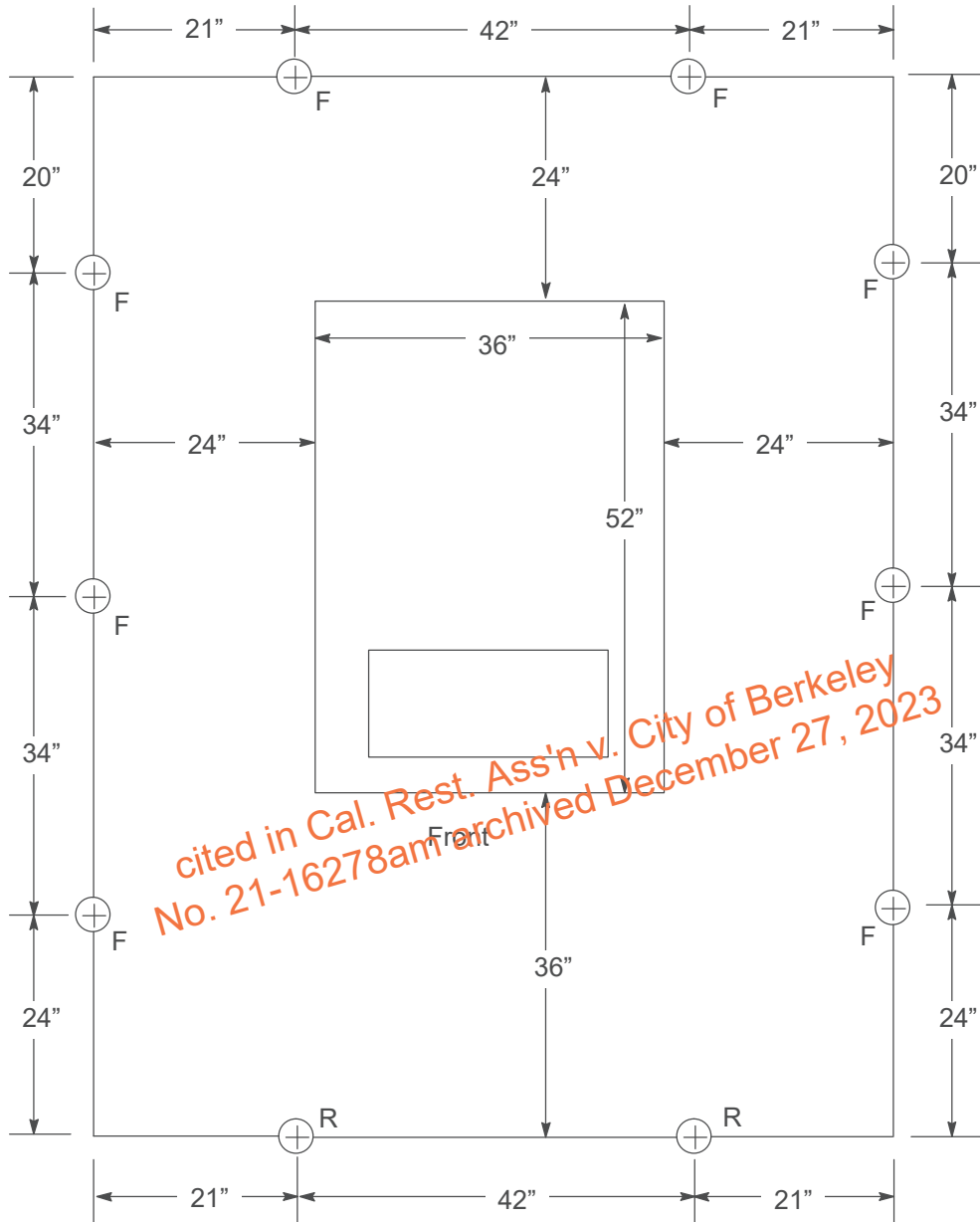
1. "A" must be less than or equal to 42 inches.
2. "B" must be greater than or equal to 12 inches on non-operable sides.
3. "B" must be greater than or equal to 36 inches on operable sides.
4.  $B_n$  must be greater than or equal to  $(A_n/2)+3$ .

**Table 3 Common A and B Pairs**

"A" (inches)	"B" (inches)
18	12
24	15
30	18
42	24
42	36

### Clearances and Location Requirements for Enclosures, Pads, and Underground Equipment

#### 13. Preferred Barrier Post Arrangement for Transformers



*cited in Cal. Rest. Ass'n v. City of Berkeley  
No. 21-16278am archived December 27, 2023*

**Figure 11**  
**Style DF-LB Box Pad**  
**36" x 52"**  
**(Document 064309)**

F = Fixed  
R = Removable

### Clearances and Location Requirements for Enclosures, Pads, and Underground Equipment

#### 13. Preferred Barrier Post Arrangement for Transformers (continued)

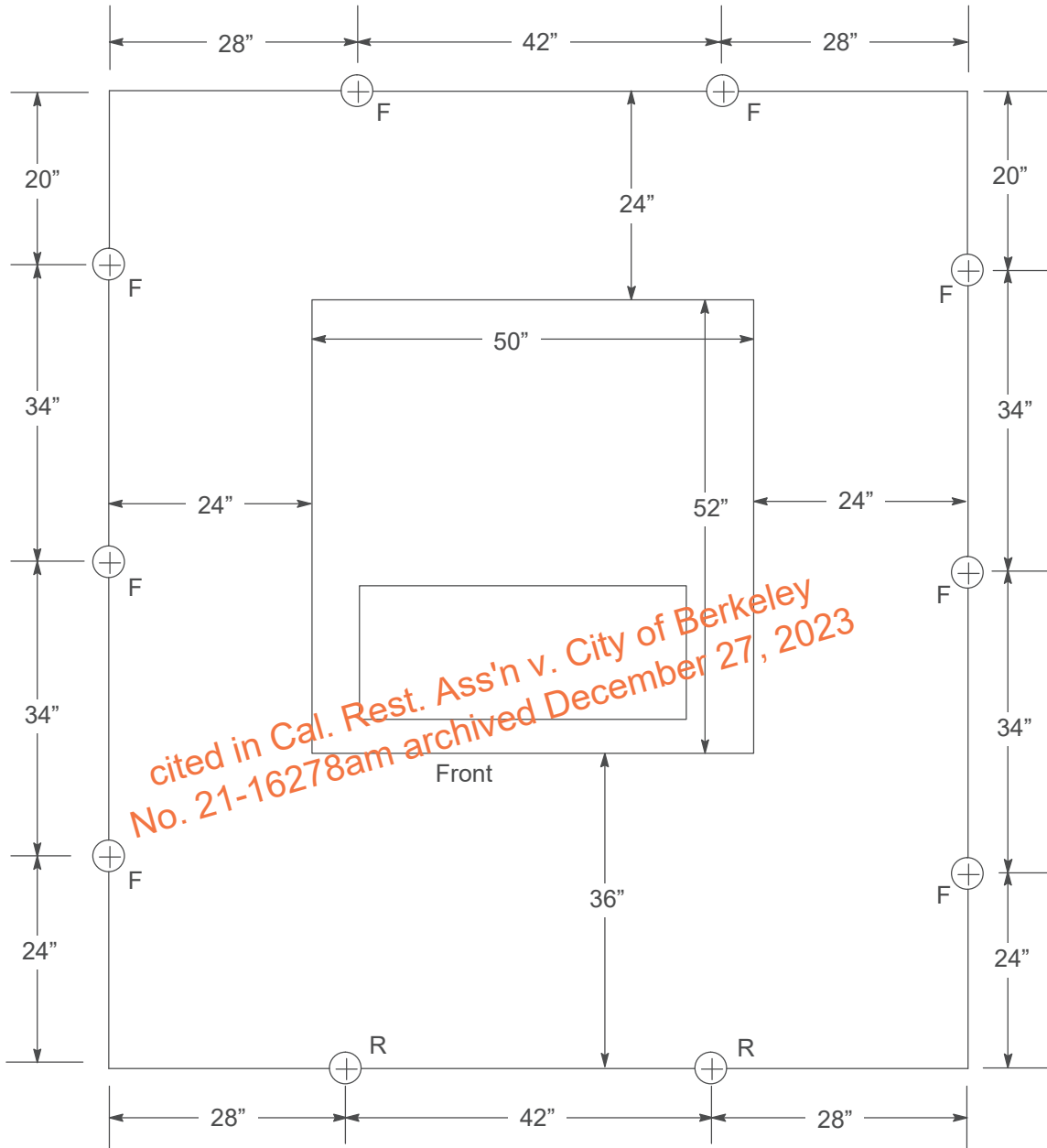


Figure 12  
Style DF-LB Box Pad  
50" x 52"  
(Document 064309)

F = Fixed  
R = Removable



### Clearances and Location Requirements for Enclosures, Pads, and Underground Equipment

#### 13. Preferred Barrier Post Arrangement for Transformers (continued)

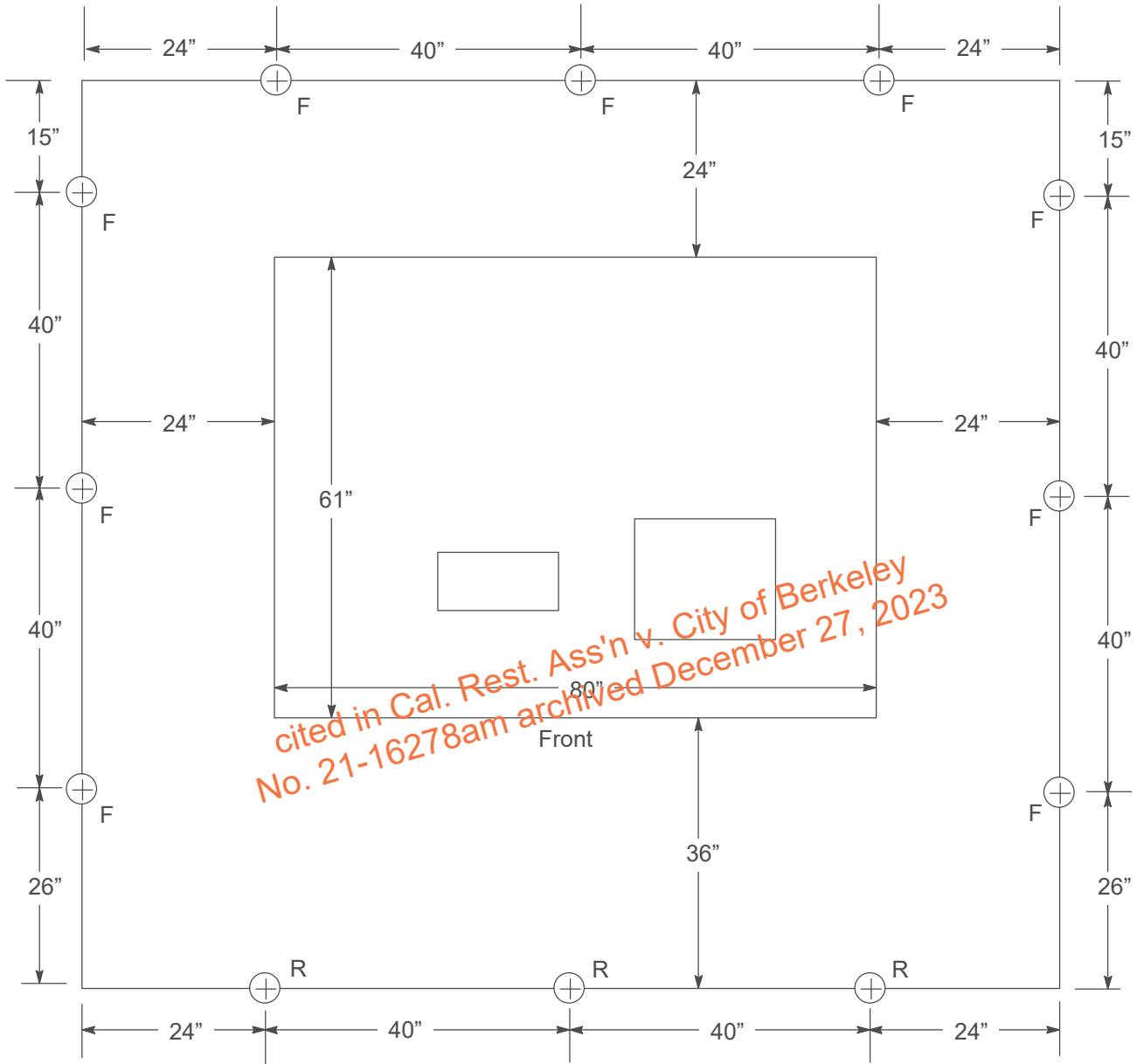
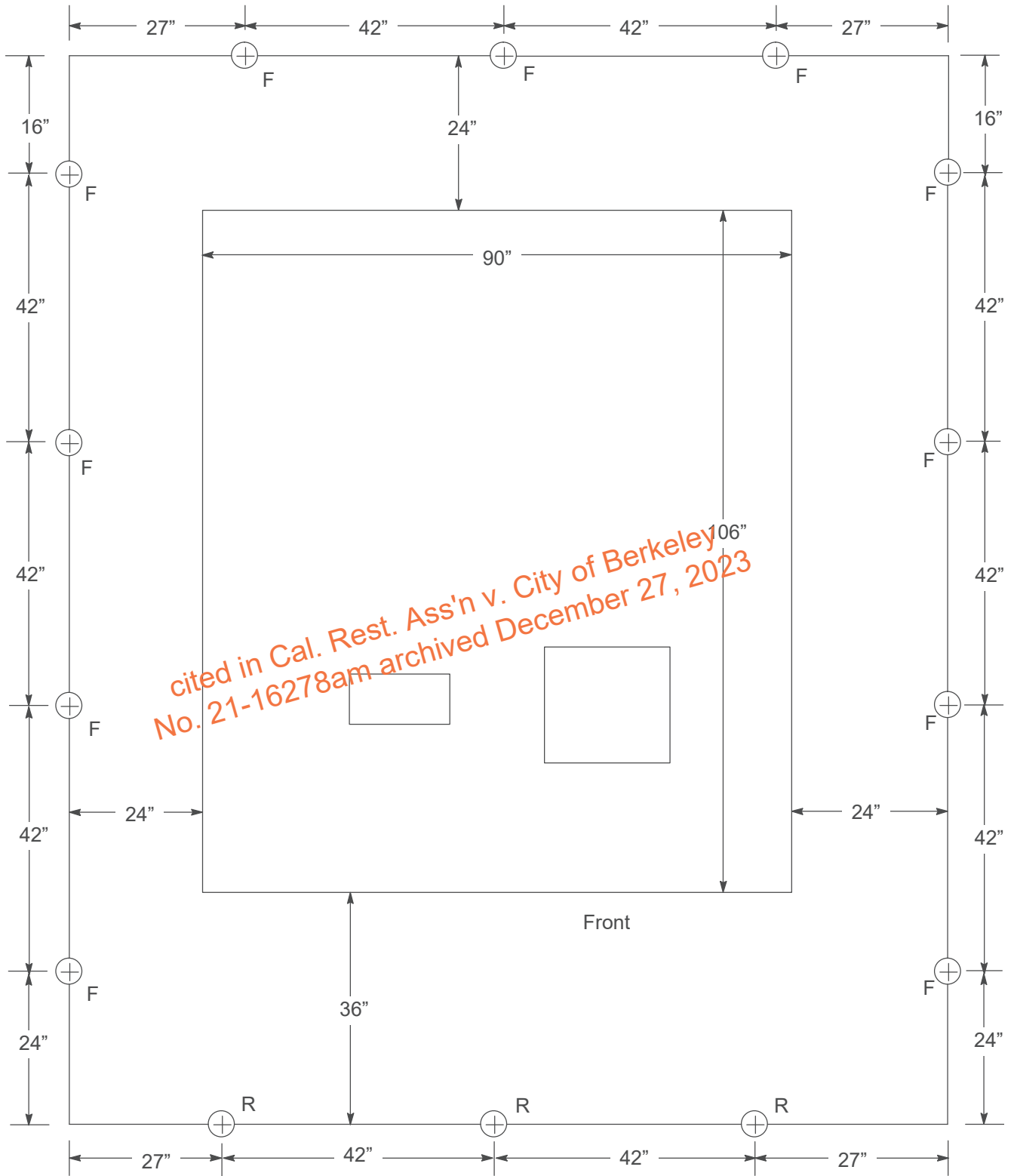


Figure 13  
Style IIE-LB Pad  
80" x 61"  
(Document 045292)

F = Fixed  
R = Removable

**Clearances and Location Requirements for Enclosures, Pads, and Underground Equipment**

**13. Preferred Barrier Post Arrangement for Transformers (continued)**

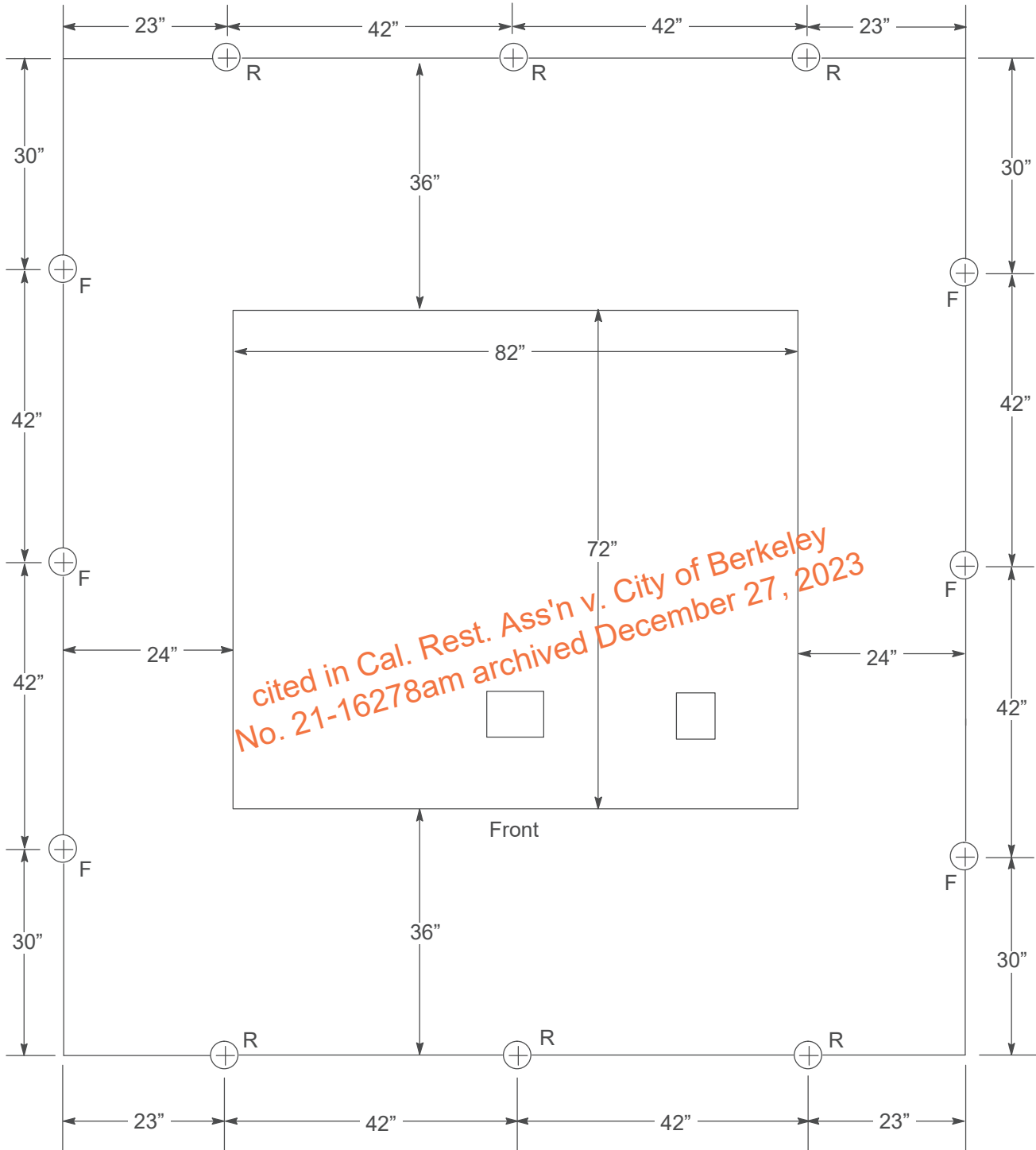


F = Fixed  
 R = Removable

**Figure 14**  
**Style IIE-LB Pad**  
**90" x 106"**  
**(Document 045292)**

### Clearances and Location Requirements for Enclosures, Pads, and Underground Equipment

#### 14. Barrier Posts for Capacitors



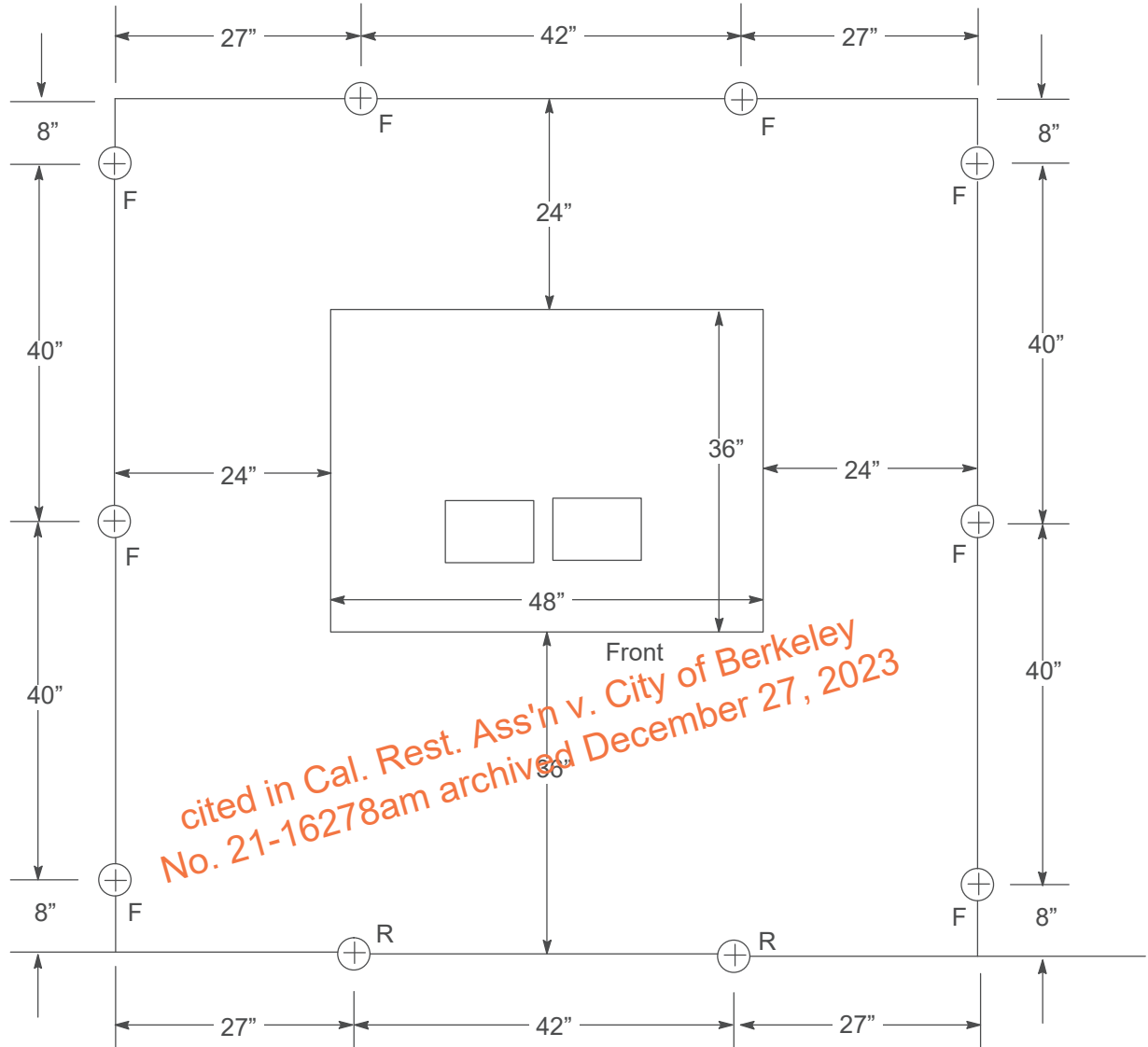
*cited in Cal. Rest. Ass'n v. City of Berkeley  
No. 21-16278am archived December 27, 2023*

**Figure 15**  
**Pad-Mount Capacitor**  
**82" x 72"**  
**(Document 066197)**

F = Fixed  
R = Removable

**Clearances and Location Requirements for Enclosures, Pads, and Underground Equipment**

**15. Barrier Posts for J-Boxes**

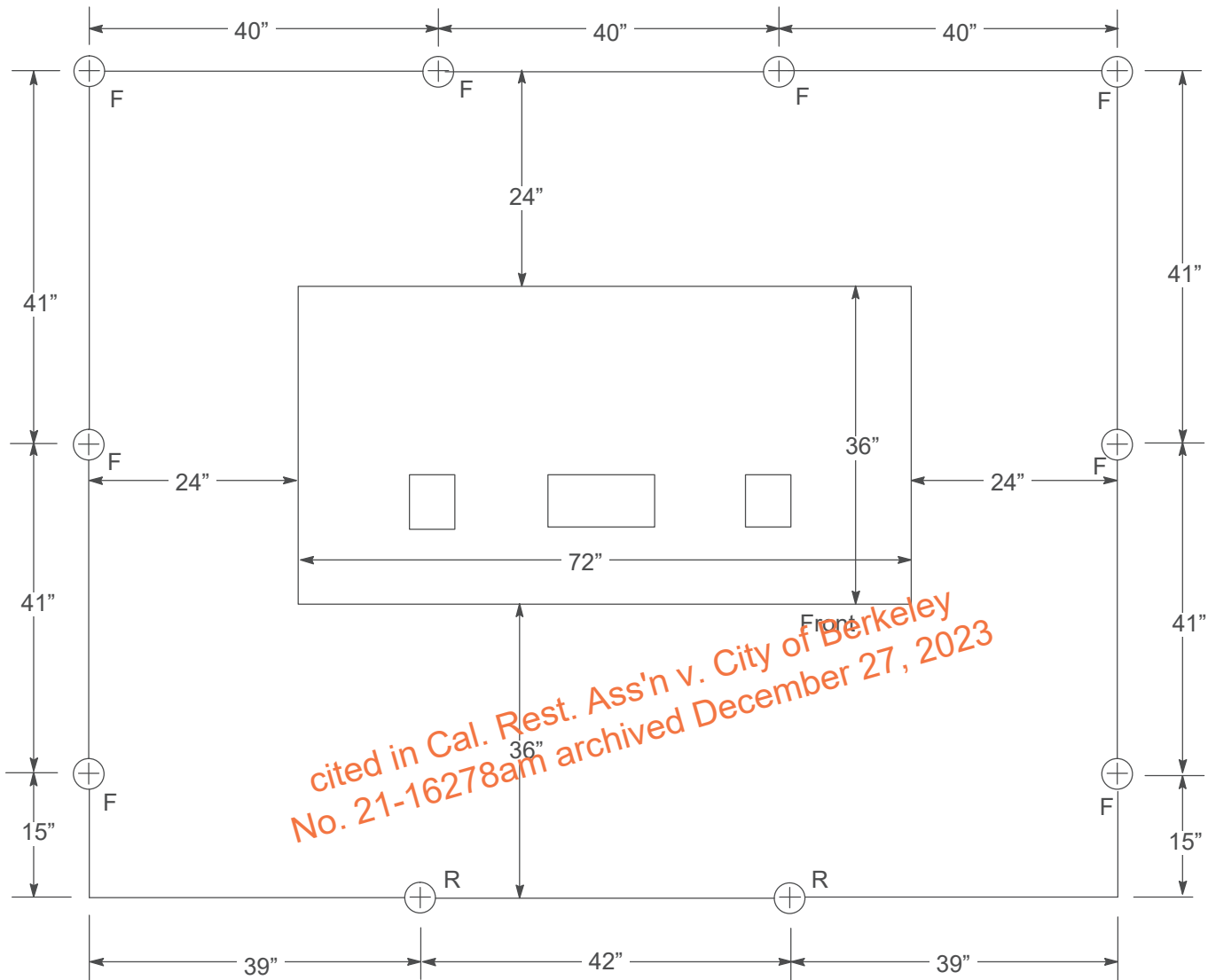


**Figure 16**  
**1-Wire, Pad-Mounted Junction**  
**48" x 36"**  
**(Document 066212)**

F = Fixed  
 R = Removable

### Clearances and Location Requirements for Enclosures, Pads, and Underground Equipment

#### 15. Barrier Posts for J-Boxes (continued)

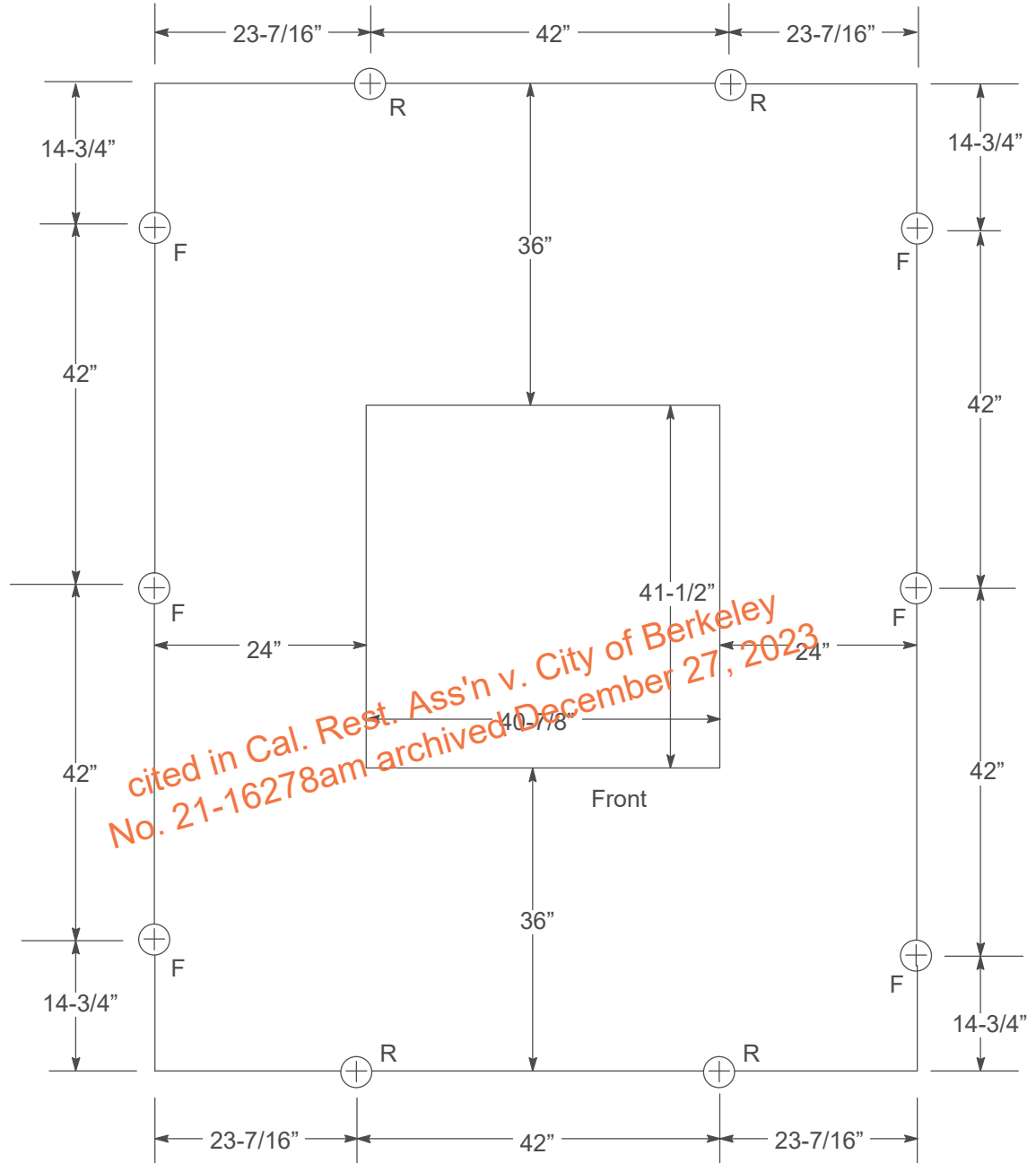


**Figure 17**  
**2- or 3-Wire Pad-Mounted Junction**  
**72" x 36"**  
**(Document 066212)**

F = Fixed  
R = Removable

**Clearances and Location Requirements for Enclosures, Pads, and Underground Equipment**

**16. Barrier Posts for PMH Switch**



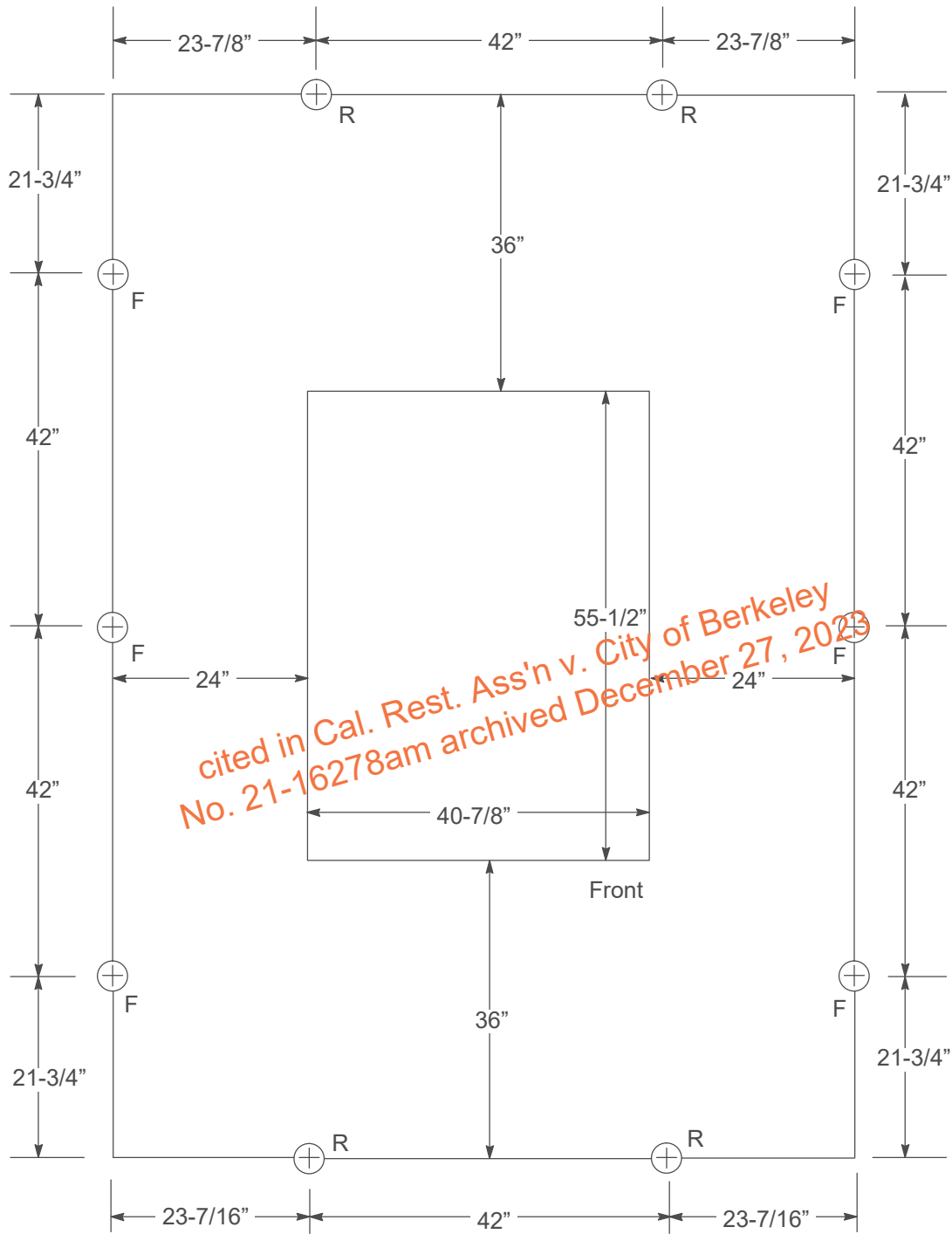
*cited in Cal. Rest. Ass'n v. City of Berkeley  
No. 21-16278am archived December 27, 2023*

**Figure 18**  
**PMH Switchgear**  
**40-7/8" x 41-1/2"**  
**(Document 053318)**

F = Fixed  
 R = Removable

### Clearances and Location Requirements for Enclosures, Pads, and Underground Equipment

#### 16. Barrier Posts for PMH Switch (continued)



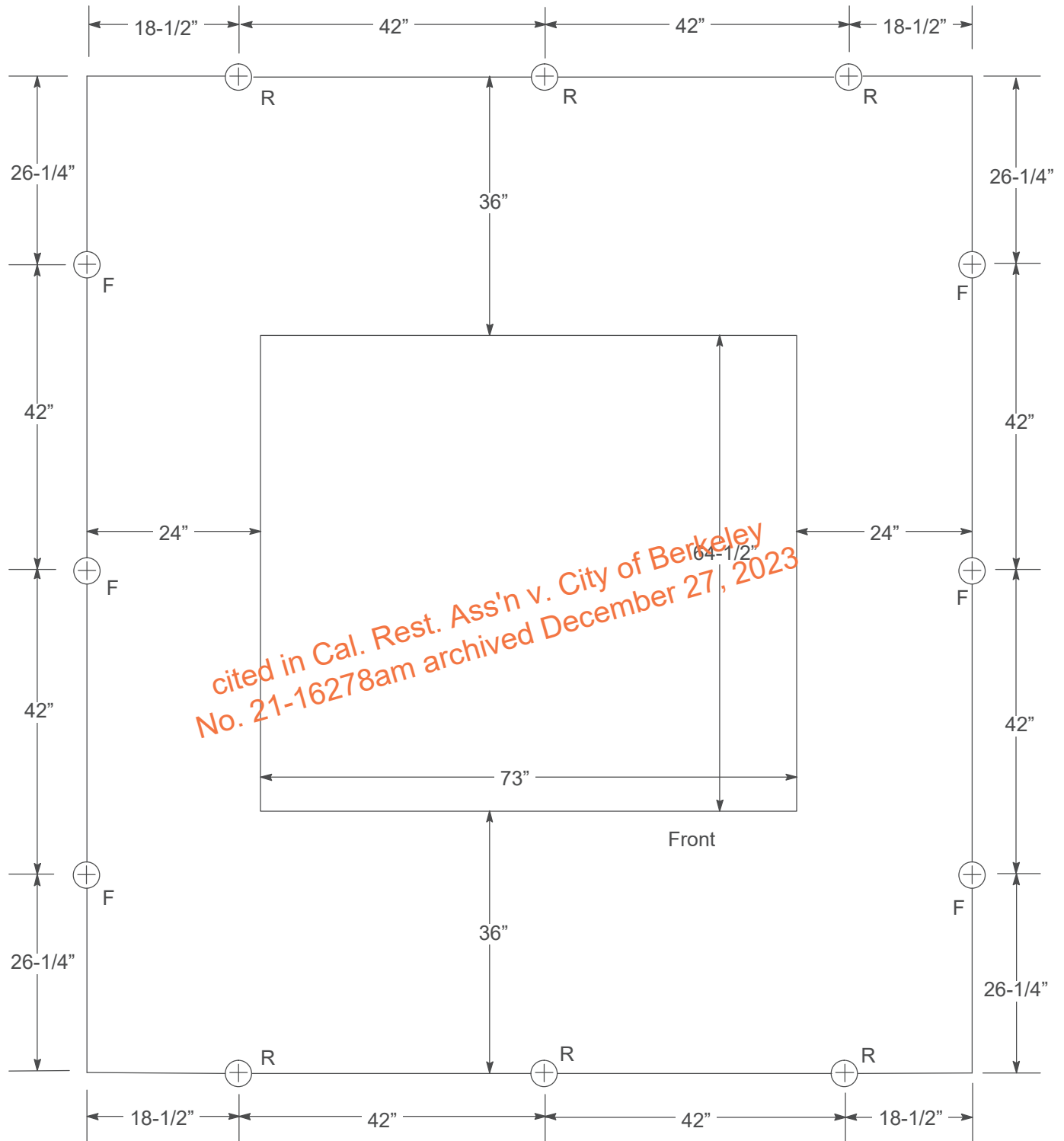
*cited in Cal. Rest. Ass'n v. City of Berkeley  
No. 21-16278am archived December 27, 2023*

**Figure 19**  
**PMH Switchgear**  
**40-7/8" x 55-1/2"**  
**(Document 053318)**

F = Fixed  
R = Removable

**Clearances and Location Requirements for Enclosures, Pads, and Underground Equipment**

**16. Barrier Posts for PMH Switch (continued)**



*cited in Cal. Rest. Ass'n v. City of Berkeley  
No. 21-16278am archived December 27, 2023*

**Figure 20**  
**PMH Switchgear Pad**  
**73" x 64-1/2"**  
**(Document 053318)**

F = Fixed  
R = Removable



### Clearances and Location Requirements for Enclosures, Pads, and Underground Equipment

#### 16. Barrier Posts for PMH Switch (continued)

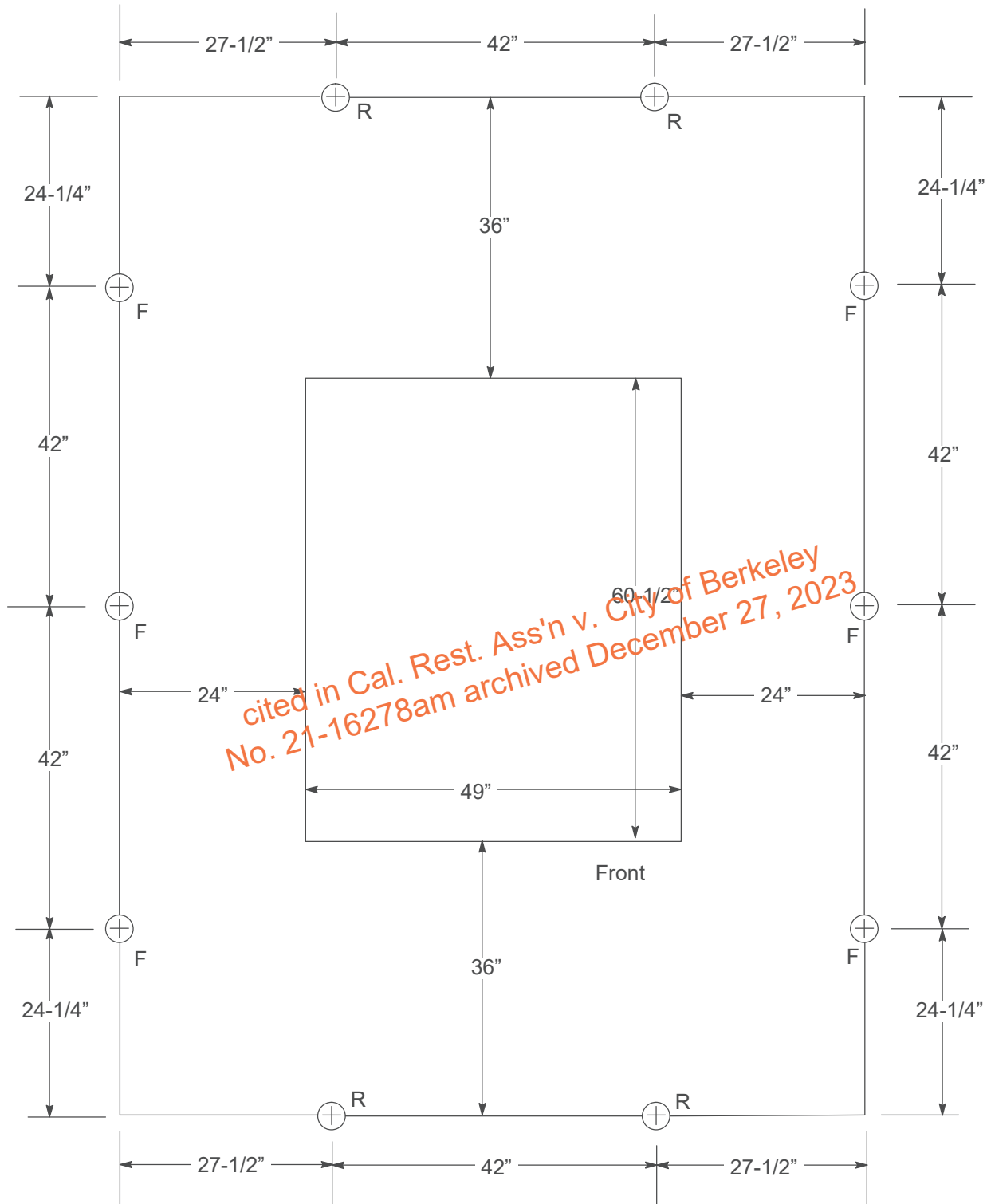
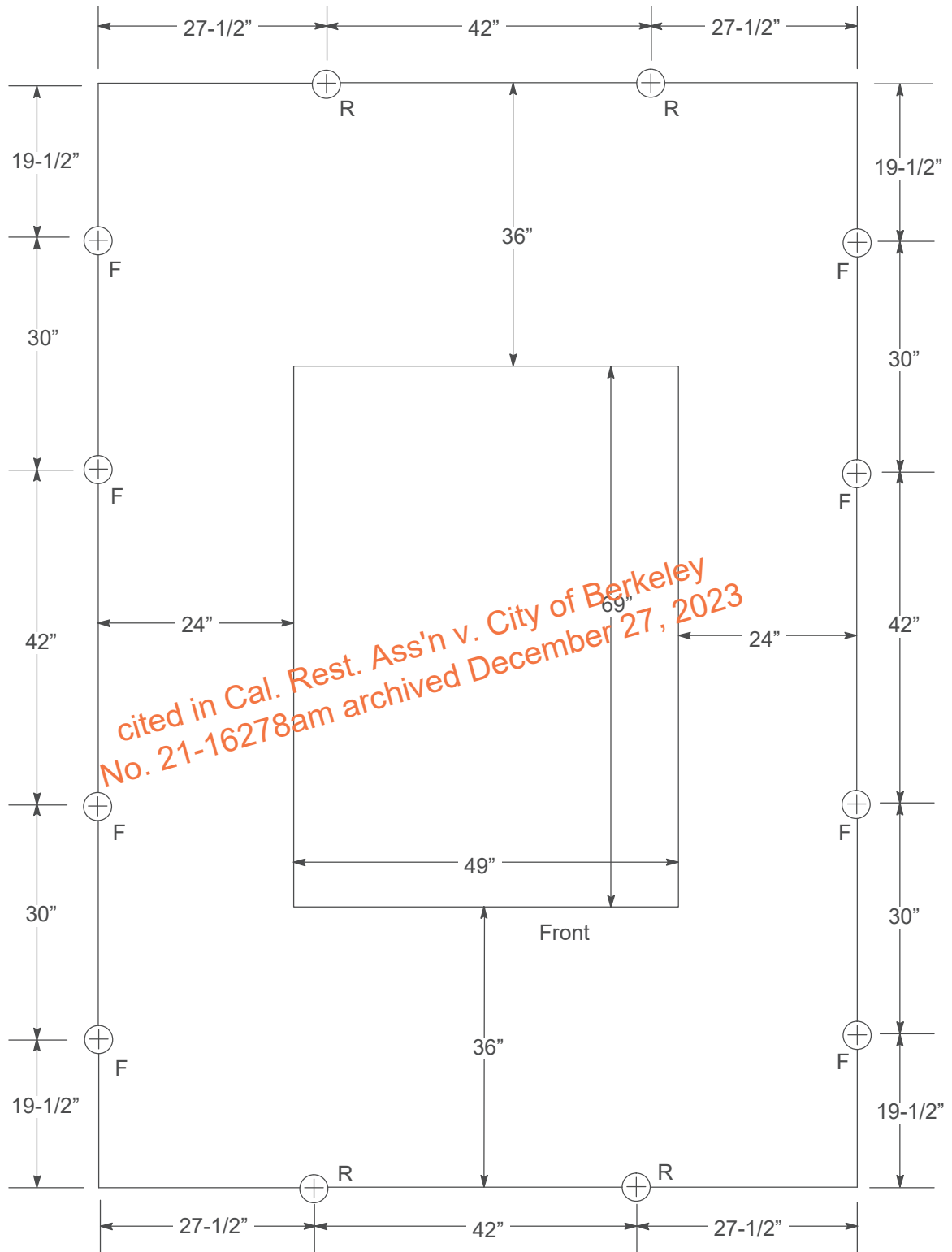


Figure 21  
PMH Switchgear Pad  
49" x 60-1/2"  
(Document 053318)

F = Fixed  
R = Removable

**Clearances and Location Requirements for Enclosures, Pads, and Underground Equipment**

**16. Barrier Posts for PMH Switch (continued)**



*cited in Cal. Rest. Ass'n v. City of Berkeley  
No. 21-16278am archived December 27, 2023*

F = Fixed  
R = Removable

**Figure 22**  
**PMH Switchgear Pad**  
**49" x 69"**  
**(Document 053318)**

### Clearances and Location Requirements for Enclosures, Pads, and Underground Equipment

#### 16. Barrier Posts for PMH Switch (continued)

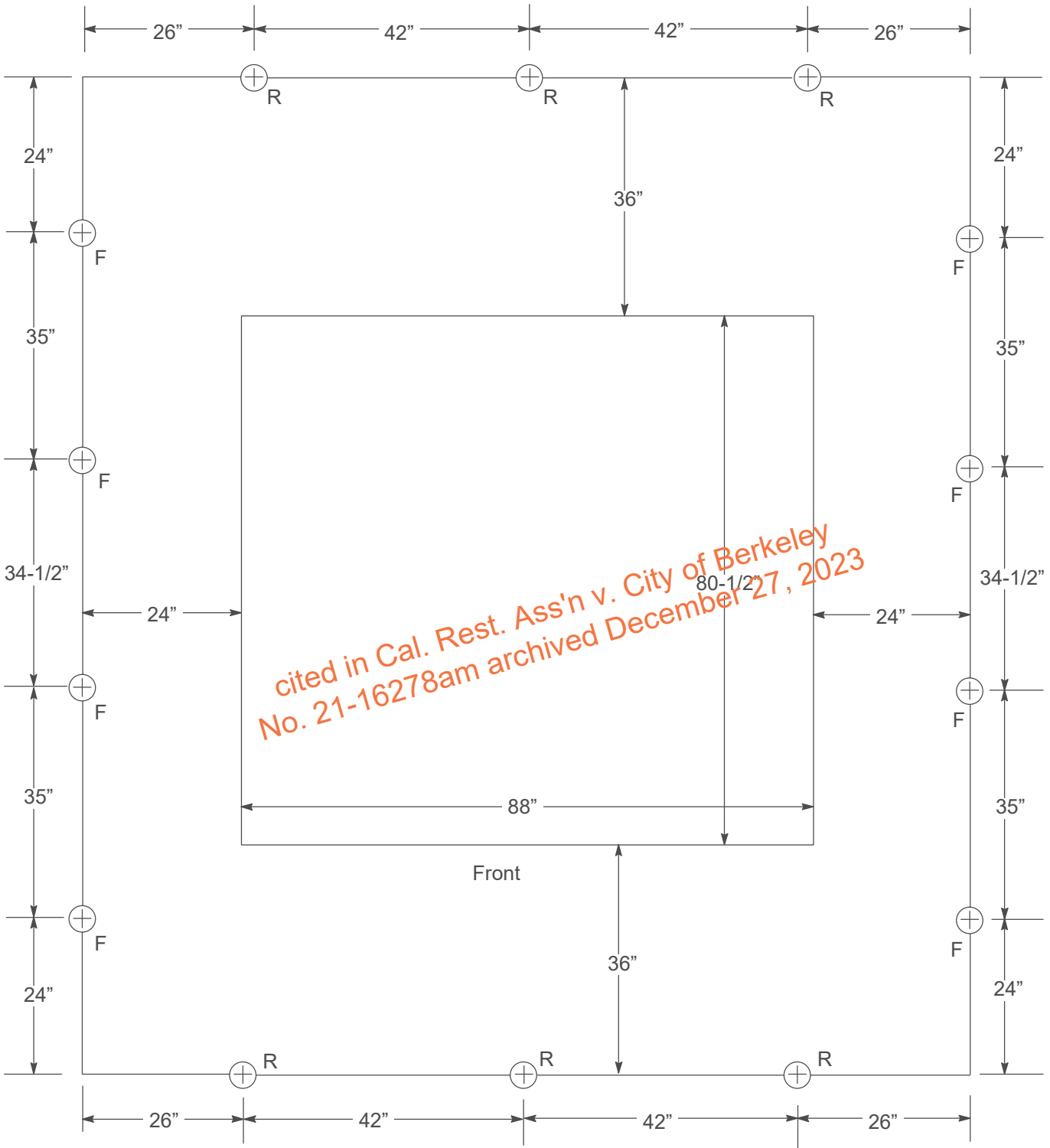
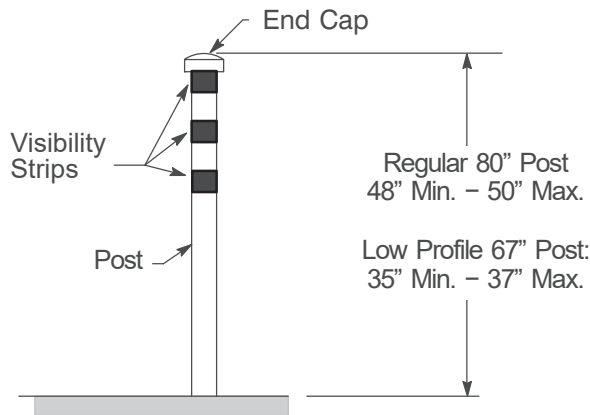


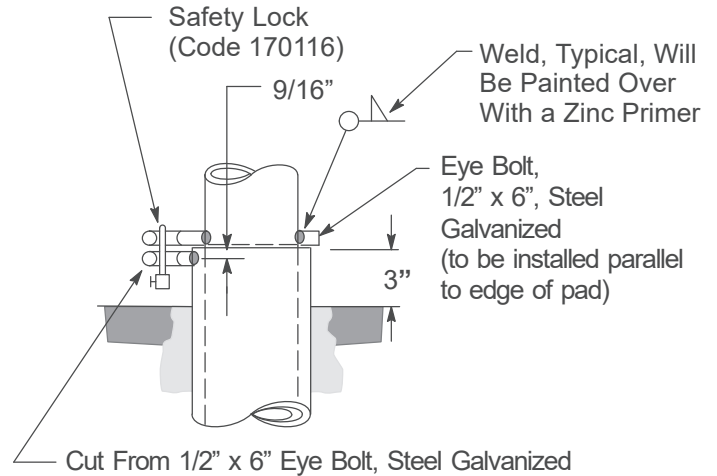
Figure 23  
PMH Switchgear Pad  
88" x 80-1/2"  
(Document 053318)

## Clearances and Location Requirements for Enclosures, Pads, and Underground Equipment

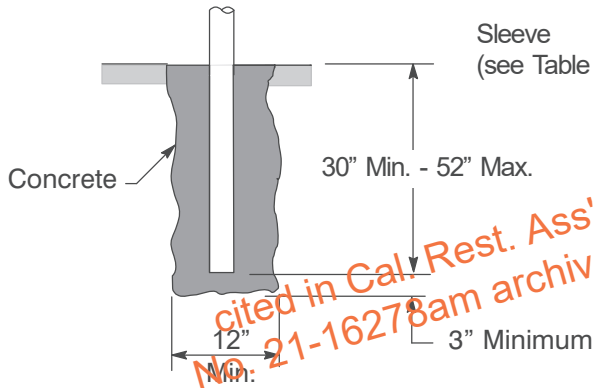
### 17. Placement of Metal Barrier Posts and Details



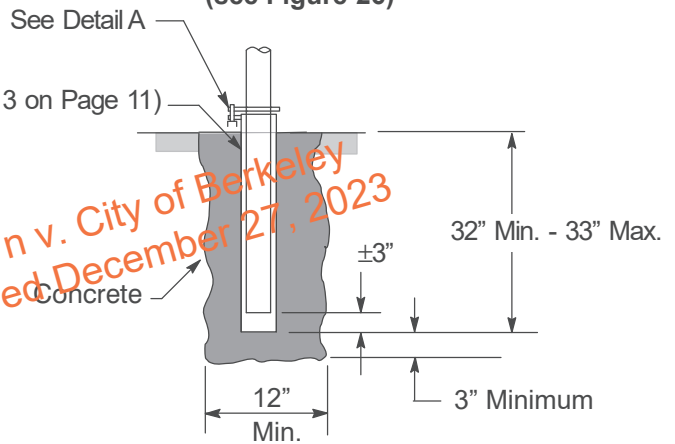
**Figure 24**  
Steel Barrier Post  
(see Table 4)



**Detail A**  
(see Figure 26)



**Figure 25**  
Footing for Fixed Steel Post Detail  
(see Table 4)



**Figure 26**  
Footing for Removable Steel Post Detail  
(see Table 4)

**Table 4 Description and Codes for Steel Barrier Posts <sup>1</sup>**

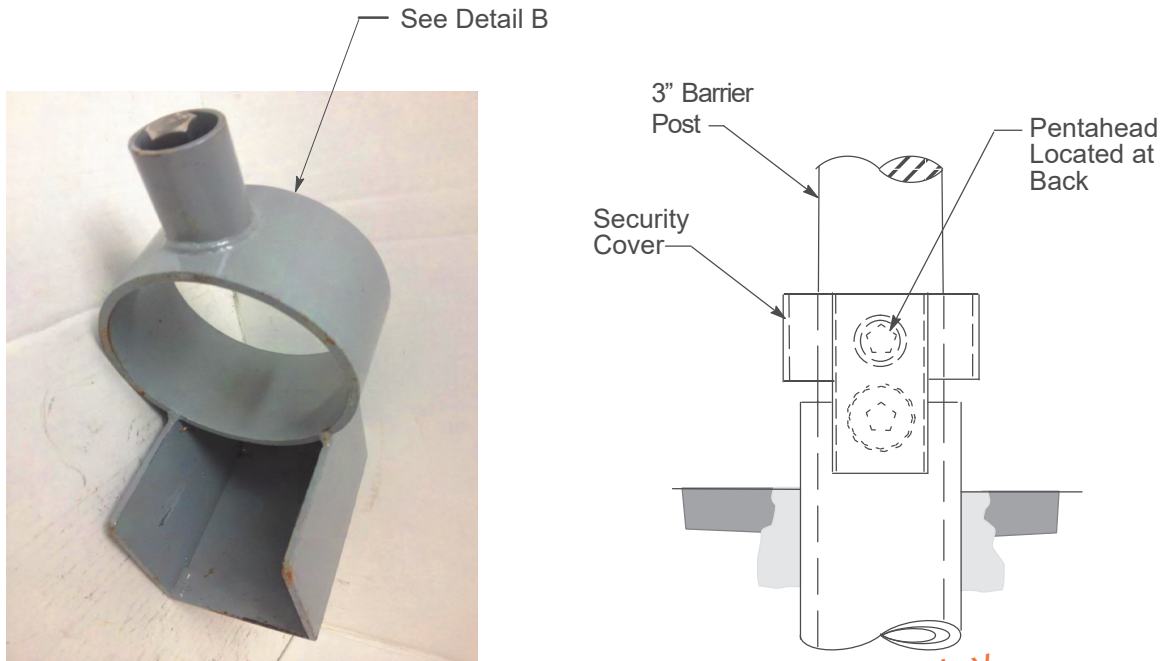
Description	Length (inches)	Code	Doc
Galvanized Fixed Post, 4", Steel Pipe, Standard, Schedule 40	80	155107	-
	67 <sup>2</sup>	155108	-
Removable Post, 4", Galvanized Steel Pipe, Standard, Schedule 40 With 5" Galvanized Steel Pipe Sleeve, 36" Long, Standard, Schedule 40	80	155105	-
	67 <sup>2</sup>	155106	-
Replacement 4" Removable Barrier Post Galvanized Steel Pipe With Cap Less Sleeve and Eye Bolt	67	150265	-
	80	150266	-
End Cap, 4", Galvanized Malleable Iron, May Be Screwed	-	021882	-
Strip, Visibility Reflective Yellow Adhesive Sheet, 2" X 12", Pacific Utilities #PEM212F, Almetek #DL-RY2X12-A	-	013163	<a href="#">022168</a>
Safety Lock	-	170116	-

<sup>1</sup> Posts fabricated from 20-foot lengths of galvanized steel pipe, Code 011794.

<sup>2</sup> 67" post length is for single-phase transformer.

### Clearances and Location Requirements for Enclosures, Pads, and Underground Equipment

#### 17. Placement of Metal Barrier Posts and Details (continued)



**Figure 27**  
**Security Cover for Removable Post Lock**  
**Material Code 150271**

**Detail B**  
**See Figure 27**

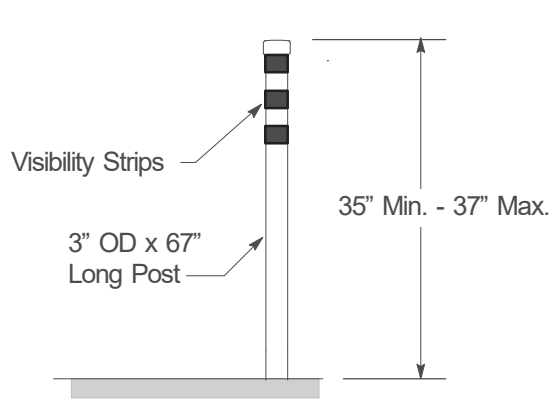
*cited in Cal. Rest. Ass'n v. City of Berkeley  
No. 21-16278am archived December 27, 2023*

Installation of Security Cover:

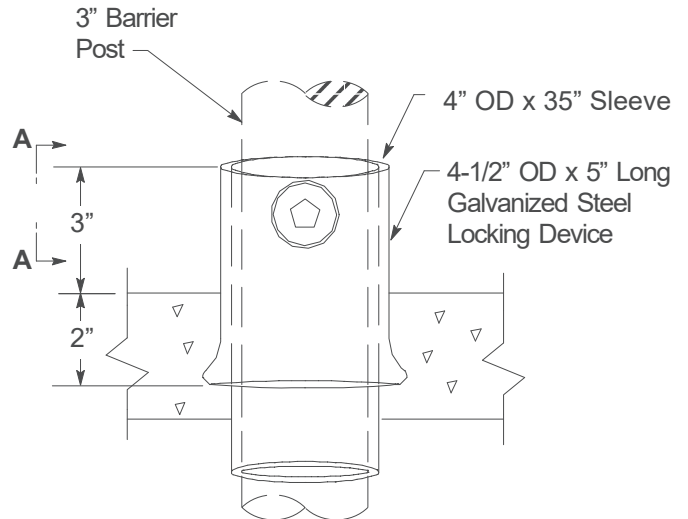
1. Remove Top Cap.
2. Slide Collar Down Over the Eyebolts Locked Together.
3. Drill Hole for Bolt.
4. Insert and Engage Pentahead Bolt.

**Clearances and Location Requirements for Enclosures, Pads, and Underground Equipment**

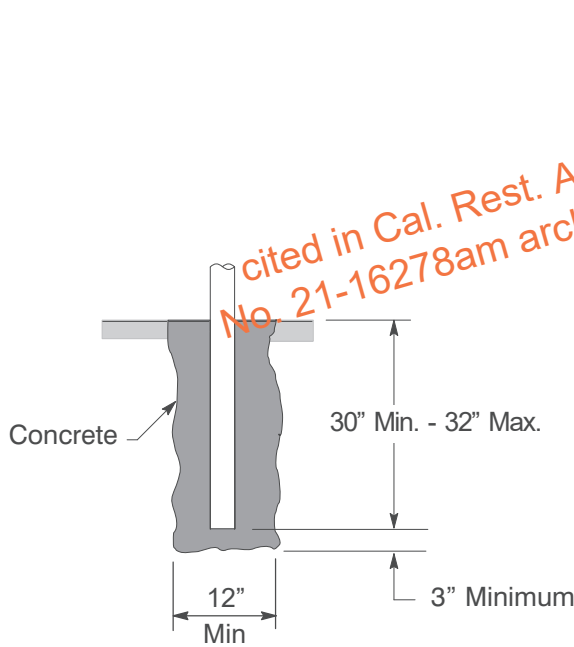
**18. Residential and Light Commercial Non-Metallic Barrier Post**



**Figure 28**  
**Non-Metallic Barrier Post**  
 (see Table 5)

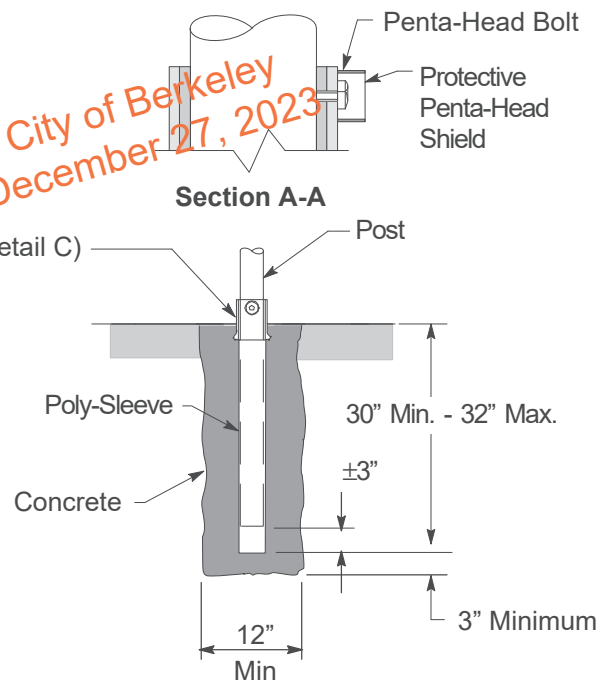


**Detail C**  
 See Figure 30



**Figure 29**  
**Footing for Fixed Non-Metallic Post**

*cited in Cal. Rest. Ass'n v. City of Berkeley No. 21-16278am archived December 27, 2023*



**Figure 30**  
**Footing for Removable Non-Metallic Post Kit**  
 (see Table 5)

**Table 5 Description and Codes for Non-Metallic Barrier Posts**

Description	Allwire	Code
<b>Fixed Post:</b> 3" OD x 67" Long, 1-3/4" Fiberglass Core With 5/8" Polyethylene Cover	FGP674	150553
<b>Removable Post Kit:</b> 4" OD x 35" Long Polyethylene Sleeve, 4-1/2" OD x 5" Long Galvanized Steel Locking Device and 1/2" x 1-1/4" Penta-Head Bolt	RPK001	150554
<b>Security Cover for Removable Post Lock</b>	-	150271

## Clearances and Location Requirements for Enclosures, Pads, and Underground Equipment

---

### Revision Notes

Revision 22 has the following changes:

1. Changed Document Owner.
2. Revised Section 4B and Section 12 to incorporate notes on equipment with Control Cabinets. Care should be taken in the layout for Barrier Posts to assure a permanent post is not installed that would prevent a cabinet from being fully opened allowing access to the internal controls.

*cited in Cal. Rest. Ass'n v. City of Berkeley  
No. 21-16278am archived December 27, 2023*

Prepared by: ABB1

	<b>ELECTRICAL SERVICE REQUIREMENTS FOR MOBILE HOME DEVELOPMENTS</b>		<b>052521</b>
	<b>Asset Type:</b> Electric Metering		<b>Function:</b> Construction
<b>Issued by:</b> Quoc Hoang (QxH1)		<b>Date:</b> 11-01-18	
<b>Rev. #07:</b> This document replaces PG&E Document 052521, Rev. #06 For a description of the changes, see Page 8.			

This document is also included in the following manuals:

- [Electric Meter Work Practices](#)

### Purpose and Scope

This document shows methods of supplying underground electric service to meter equipment (pedestal) serving mobile homes in accordance with [Electric Rule 15](#) and [Electric Rule 16](#) for a park that qualifies as a mobile home development as defined by PG&E. Additionally refer to PG&E's Electric and Gas Service Requirements manual ([Greenbook](#)) for additional requirements that may not be listed in this document.

Note: In accordance with Title 25, Article 7, Sections 1322, 1333, and 1333.5, mobile homes installed on foundation systems in locations other than mobile home parks, may be served by PG&E from overhead or underground service to the customer's equipment (service entrance conductors if overhead), which is attached directly to the mobile home. Refer to PG&E [Document 063927](#) for underground service requirements and [Documents 025202](#) and [022169](#) for overhead service requirements.

### Instructions

1. The developer or his contractor shall provide all necessary trenching, secondary and service conduit (when required), and shall be responsible for the location and final grade of the utility islands
2. The required location for the meter equipment is at the front of the mobile home (see Figure 1 on Page 4). Alternate locations for the meter pedestal are indicated by the shaded areas in Figure 1 on Page 4.
3. PG&E shall install the secondary and service lateral cables in accordance with current engineering standards and construction methods.
4. Maintain a 36-inch (minimum) work space clearance from the meter face and from any access panel to PG&E facilities on the enclosure. Maintain a 36-inch (minimum) clearance from the meter equipment to other utility equipment such as gas, water or sewer. Refer to the National Electrical Code and the Authority Having Jurisdiction for the allowed working space requirements and if the 36-inch (minimum) clearance shown in Figure 3 and Figure 4 on Page 5 may be reduced to 12 inches for pedestal designs which have the meter and all access panels (both PG&E's and customer's) located on the same side of the pedestal.
5. Before PG&E has installed the cable, the developer or his contractor shall then:
  - A. Install the electric meter pedestal in place over the conduit. Position the pedestal so the meter socket faces toward the street as shown on Page 5 or away from mobile home. Maintain the work space and clearances as described in Note 4.
  - B. Install and connect a copper grounding conductor from the pedestal grounding lug to an N.E.C. approved ground electrode system. The grounding connection shall not be made to a gas piping system. The customer shall be responsible for bonding and grounding all exposed non-current-carrying metal parts in accordance with the applicable electric codes and local ordinances. PG&E prefers, but does not require, the grounding electrode conductor wire to be protected against physical damage by rigid steel conduit or armored cladding. Refer to the NEC for any required clearance distance of the ground rod away from the pedestal. The top of the ground rod may be exposed or buried as required to meet the applicable electric codes. Exposed ground rods should be placed so they are not a tripping hazard.
  - C. Bond the service neutral termination lug to the meter pedestal by means of a bonding screw, or by continuing the grounding conductor between the grounding lug and the neutral lug.



**Electrical Service Requirements for Mobile Home Developments**

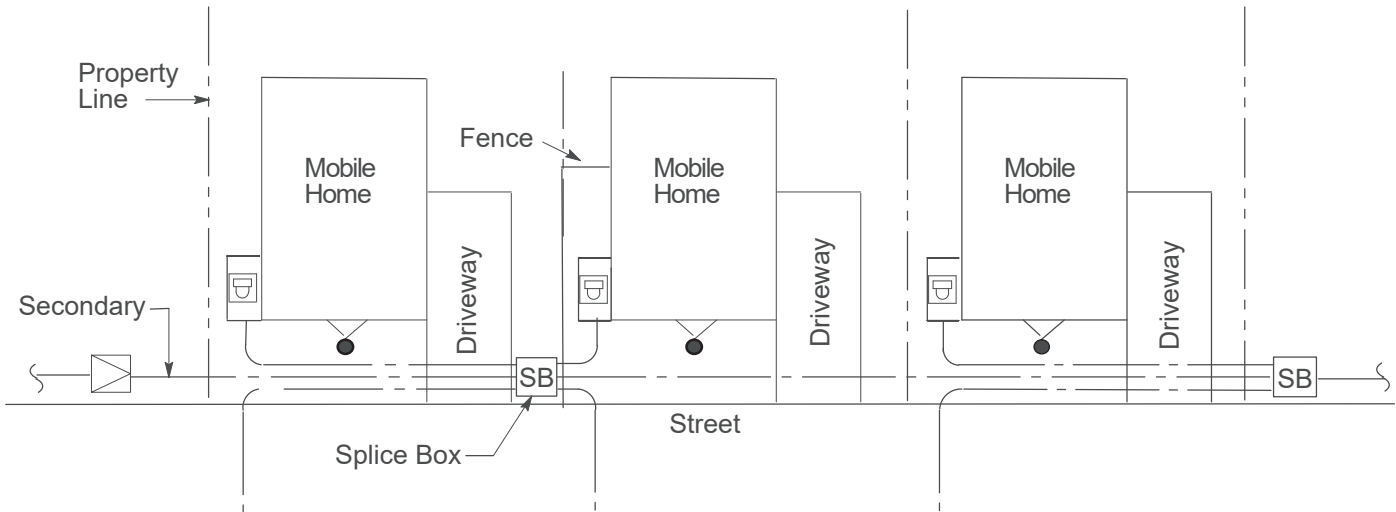
- D. Backfill around the pedestal to provide good support, plumb and level the pedestal, and pour the concrete base support or island. The concrete surface should be no more than 1-inch above grade and 1-inch to 2-inch below the bottom of the utility section opening.
- E. Backfill all trenches, and furnish any imported backfill material required.
6. PG&E shall connect the service lateral conductors to the termination lugs in the meter pedestal, install and seal the pull section panel, and blank off and seal the meter socket.
7. PG&E shall set the meter upon request for service, after required permits and inspections have been obtained from city or county inspection authorities.
8. See Figure 1 on Page 4 for a typical electric distribution system layout for a mobile home development.
9. PG&E shall design its facilities so that the short-circuit duty at the electric service entrance will not exceed 10,000 amps.
10. Mobile home pedestal shall have a minimum rating of 100 amps. The socket and enclosure shall be designed in accordance with PG&E [Document 051001](#) and the following:
- A. The minimum meter height shall be 36 inches when the meter is enclosed, or 48 inches if the meter is exposed.
  - B. When the meter is enclosed, the enclosing cover shall be hinged for ready access and shall have a shatter-proof reading window. When the meter is enclosed or recessed, the clearance from the meter centerline to any fixed side obstruction shall be a minimum of 6 inches.
  - C. The service cable pull and terminating section shall be covered with a sealable removable panel (or panels), extending from a fixed panel 1 to 2 inches above concrete. The removable panel shall allow full access to the service terminating lugs. Access to the service terminating lugs may be from either front or rear of the pedestal.
  - D. Service terminating lugs shall be twin #6 to 350 kcmil range, aluminum bodied pressure type for connecting a single-service lateral.
  - E. Lugs for terminating the user's neutral conductors shall be located outside the sealable section and shall be designed to readily permit his neutral system to be isolated, when necessary, from PG&E's neutral.
  - F. The pedestal at grade line shall have the minimum dimensions as specified on Page 8.
  - G. The minimum depth of the pedestal in the ground shall be 24 inches.
  - H. Adequate ventilation shall be provided to prevent moisture condensation inside the pedestal, as required by UL414.
  - I. Any unmetred bus going through the breaker section shall be completely covered by steel or approved plastic conduit.
11. Installation of PG&E distribution system facilities including service and metering equipment installations shall be designed and constructed in accordance with PG&E's Electric and Gas Service Requirements. Refer to the applicable sections in the [Greenbook](#) manual for additional requirements that may not be listed in this document.
12. Physical protection from vehicular traffic shall be provided in accordance with the level of vehicular exposure. Barrier posts are intended to provide reasonable warning from accidental vehicular contact, rather than to prevent all possible contact. The applicant will provide acceptable physical protection. Refer to [Document 051122](#), Clearances and Location Requirements for Enclosures, Pads, and Underground Equipment.

**Electrical Service Requirements for Mobile Home Developments**

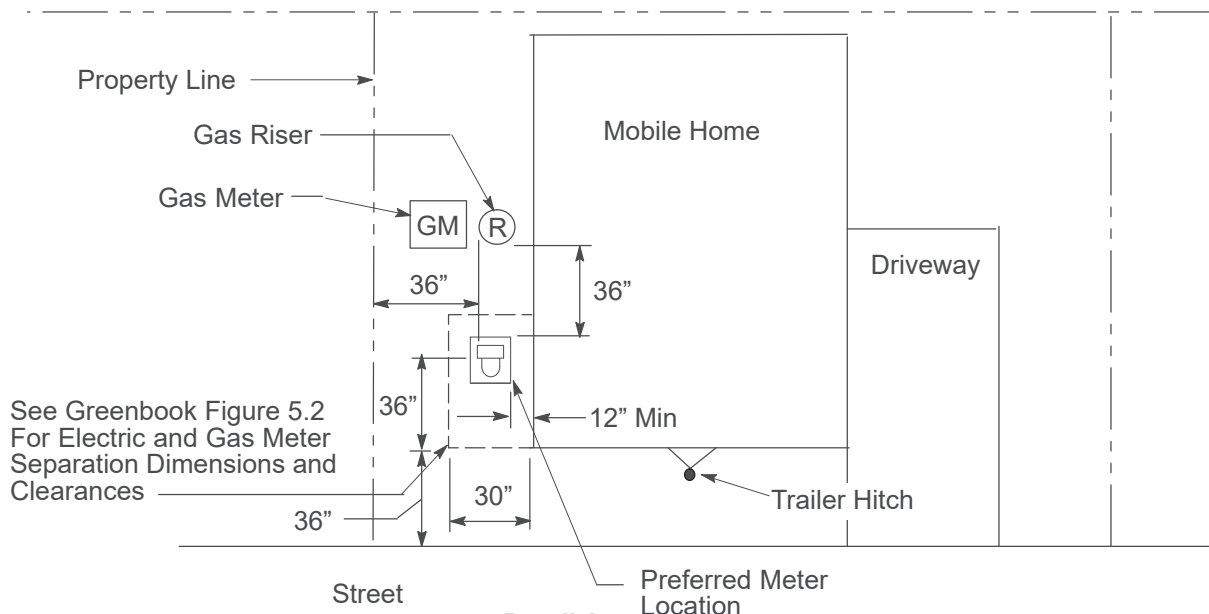
References	Location	Document
<a href="#">Connectors for Insulated Cables</a>		
<a href="#">Underground Distribution Systems</a> .....	<a href="#">UG-1: Connectors</a> .....	<a href="#">015251</a>
<a href="#">Clearances for Supply Service Drops</a> .....	<a href="#">OH: Services</a> .....	<a href="#">022169</a>
<a href="#">Methods of Attaching Services to Customer Premises</a> ..	<a href="#">OH: Services</a> .....	<a href="#">025202</a>
<a href="#">Temporary Underground Electric Service Single-Phase, 120/240 Volt, 200 Amps Maximum</a> .....	<a href="#">UG-1: Services</a> .....	<a href="#">036670</a>
<a href="#">Cables for Underground Distribution</a> .....	<a href="#">UG-1: Cable</a> .....	<a href="#">039955</a>
<a href="#">Clearances and Location Requirements for Enclosures, Pads, and Underground Equipment</a> ....	<a href="#">UG-1: General</a> .....	<a href="#">051122</a>
<a href="#">Terminating Underground Electric Services 0 – 600 Volts in Customer-Owned Facilities</a> .....	<a href="#">UG-1: Services</a> .....	<a href="#">058817</a>
<a href="#">Methods and Requirements for Installing Residential Underground Electric Services 0 – 600 to Customer-Owned Facilities</a> .....	<a href="#">UG-1: Services/Greenbook/EDM</a> .....	<a href="#">063927</a>

*cited in Cal. Rest. Ass'n v. City of Berkeley  
No. 21-16278am archived December 27, 2023*

### Electrical Service Requirements for Mobile Home Developments



**Figure 1**  
**Typical Electric Distribution System for a Mobile Home Development**



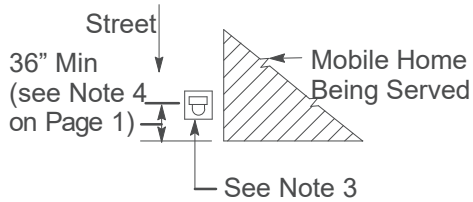
**Detail A**  
**Meter Clearance**

## Electrical Service Requirements for Mobile Home Developments

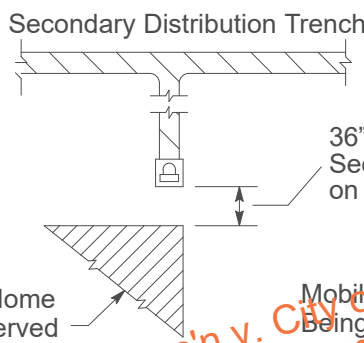
### Location of Electric Meter Pedestal

#### Notes

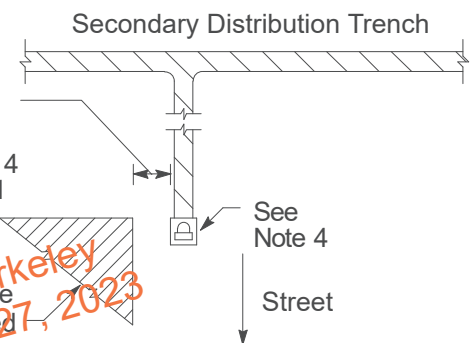
1. Position pedestal so that electric meter is faced toward the street or right of way.
2. See Figure 5 and Detail B.
3. Position pedestal so that electric meter is facing away from mobile home, towards right of way.
4. Alternate location for pedestal. Position pedestal so that electric meter is facing away from mobile home.
5. Trench depth shall be 30 inches (minimum) with or without gas service, and greater if joint with a gas main.



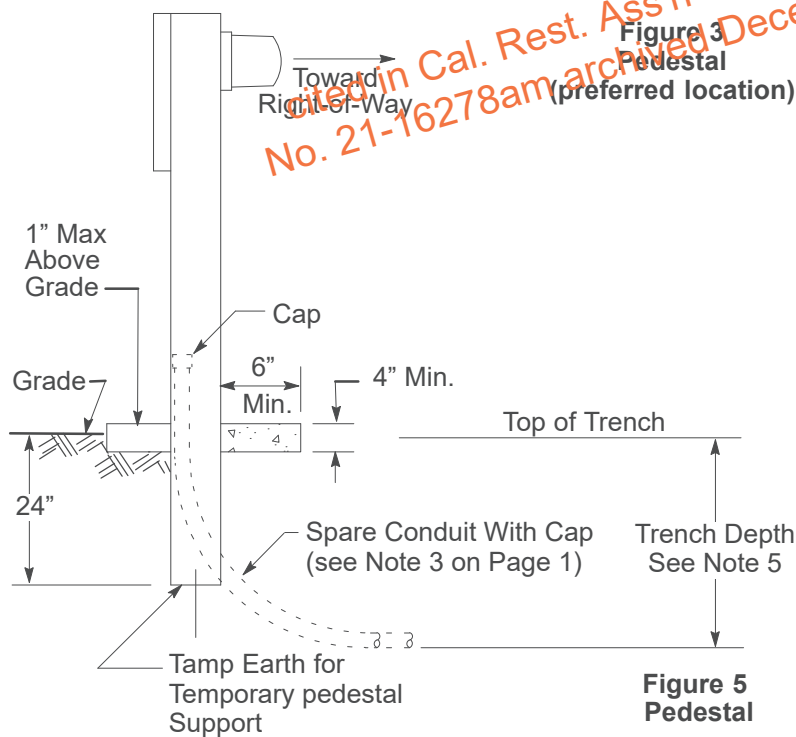
**Figure 2  
Pedestal  
(preferred location)**



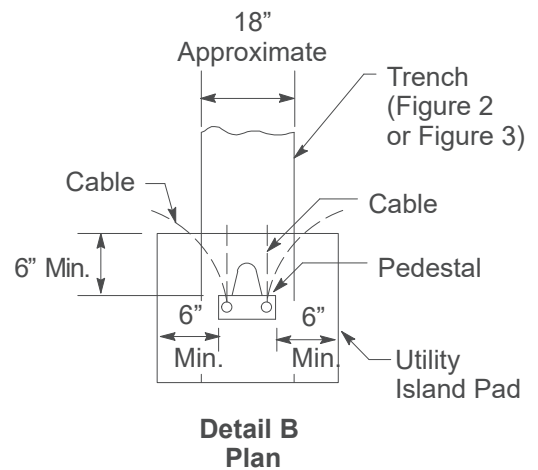
**Figure 3  
Pedestal  
(preferred location)**



**Figure 4  
Pedestal  
(alternate location)**



**Figure 5  
Pedestal**



**Detail B  
Plan**

**Electrical Service Requirements for Mobile Home Developments****Material****Notes**

1. It is recommended that the main circuit breakers used in pedestals have a 10,000-amp short-circuit current rating to insure compliance with state and local codes. These codes require that the main breaker of service equipment be rated at the available short-circuit current. PG&E shall design its facilities to supply all new mobile home customers so that the short circuit duty at the pedestal will not exceed 10,000 amps.
2. See Table 2 on Page 6 for a list of approved meter pedestal manufacturers and catalog numbers.
3. Pedestals are allowed to have rear connection kit.

**Table 1 List of Material for Supplying Electric Service to Mobile Home Developments**

Item	Description
Material to Be Supplied by Applicant	
1	Meter Pedestal (as required, see Table 2 on Page 6 for the approved list)
2	Conduit, Rigid Steel, Galvanized, with Pipe Strap (for bare ground wire, omit if armor clad wire is used)
3	Hub and Clamp, Grounding (to suit Item 3)
4	Conduit Fitting, Threaded, With Cover and Gasket (size to suit Item 3)
5	Ground Rod (see Instruction 5B on Page 1)
6	Ground Wire, Copper, Bare, or Armor Clad (size in accordance with applicable electrical codes and local requirements)
7	Conduit and Cap (as required)
Material to Be Furnished by PG&E	
8	Cable, XLP, 600-V (as required), see <a href="#">Document 039955</a> (see Table 2)

**Table 2 Approved Meter Pedestals<sup>3</sup>**

Rating (amps)	Mobile Home Electric Metering Pedestals	
	Manufacturer	Catalog Number
0 – 125	Myers Elec. Prod.	MES-M100SE
	MILBANK	MPRV Series
0 – 200	Myers Elec. Prod.	MES-M200SE
	MILBANK	MPAP Series
	MILBANK	U6276 Series

- <sup>1</sup> See Notes on Page 6.
- <sup>2</sup> Pedestals can have rear connection kits.
- <sup>3</sup> Other meter pedestal that meet EUSERC 307 and PG&E requirements may be allowed.

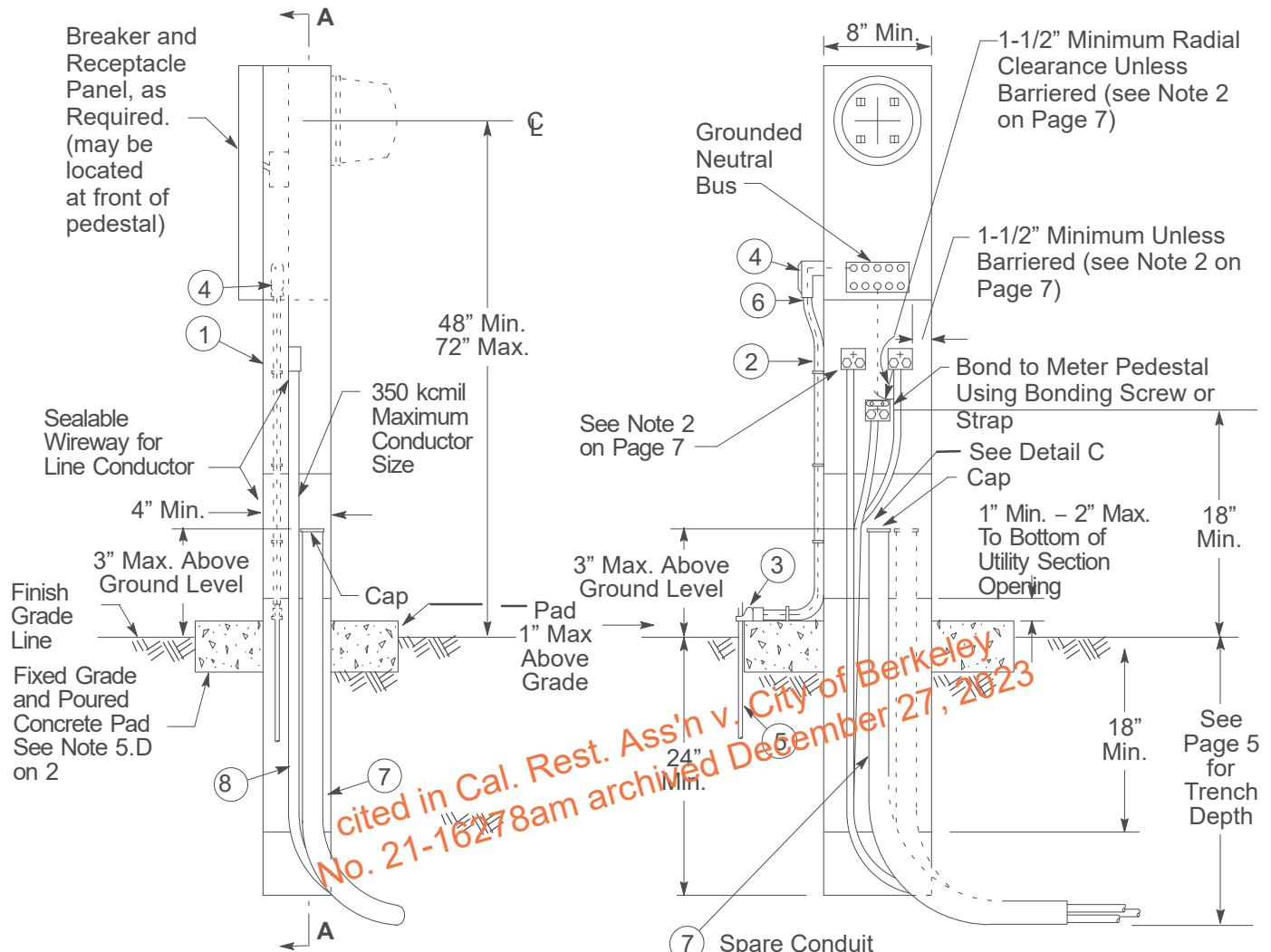
**Electrical Service Requirements for Mobile Home Developments*****Service and Meter Pedestal*****Notes**

1. The meter pedestal shown on Page 8 may be used for a single service only.
2. Termination lugs for a pedestal shall be twin #6 to 350 kcmil range, aluminum bodied pressure type for connecting a single-service lateral and a single streetlight service when needed. Lug height, measured to the bottom of the terminating lug from grade line, shall be 18 inches minimum and 36 inches maximum. The space between terminating lugs, from lugs to sides of pedestal, from lugs to any grounded surface, or from lugs to panel above shall be 1-1/2 inch minimum. Rigid insulating barriers are required and shall project 1/4-inch minimum beyond any energized parts when this space is reduced. Terminating lugs may be positioned either in-line or staggered, and access shall be unobstructed when all service conductors are in place.
3. Meter height may be reduced to 36 inches if it is enclosed or guarded by a hinged protective hood (see Note 10B on Page 2).
4. The pedestal shown on Page 8 may also be used for an underground service to an individual mobile home not in a park.
5. The pedestal shown in Figure 6 on Page 8 is limited by its pull-section size to a maximum of 350 kcmil conductors.

*cited in Cal. Rest. Ass'n v. City of Berkeley  
No. 21-16278am archived December 27, 2023*

### Electrical Service Requirements for Mobile Home Developments

#### Service and Meter Pedestal (continued)



**Figure 6**  
**Service and Meter Pedestal**


**Section A-A**  
PG&E Service Conduit  
(see Note 3 on Page 1)

**Detail C**  
**Cable and Conduit Arrangement**

#### Revision Notes

Revision 06 has the following changes:

1. Updated Notes 5.B on Page 1 and 5.D on Page 2.
2. Updated Note 10.D on Page 2.
3. Updated Figure 5 on Page 5
4. Updated Table 1 on Page 6.
5. Removed Detail C and Table 2 on Page 7 about Compression Type Terminals.
6. Updated Figure 6.

	<b>AGRICULTURAL UNDERGROUND SERVICE 500 HP OR LESS</b>	<b>054619</b>
<b>Asset Type:</b> Electric Metering		<b>Function:</b> Design and Construction
<b>Issued by:</b> Lisseth Villareal (LDV2) <i>Lisseth Villareal</i>		<b>Date:</b> 07-31-15
<b>Rev. #10:</b> This document replaces PG&E Document 054619, Rev. #09. For a description of the changes, see Page 7.		

**This document is also included in the following manual:**

- [Electric and Gas Service Requirements \(Greenbook\)](#)
- [Electric Meter Work Practices](#)

**Purpose and Scope**

This document establishes and illustrates the preferred methods of providing underground agricultural service of 500 hp or less.

The requirements shown on this document shall apply to agricultural underground service installations, from PG&E's overhead lines, for connected loads of 500 hp or less. This document applies where there is a suitable service post, building, or structure as approved by PG&E for attaching the service conduit and metering equipment. For requirements applicable to agricultural service poles (overhead service only) refer to PG&E's [Document 058087](#). The customer should contact the local PG&E office for installations larger than 500 hp or other underground installations from underground systems as these installations may require different facilities.

**General Information**

1. PG&E shall furnish and install transformers, service conductors (in accordance with [PG&E's Electric Rule 16](#)), meters, and metering current transformers. Unless otherwise stated, all other materials shall be furnished, installed, and maintained by the customer and shall comply with the requirements of PG&E. It shall be the responsibility of the customer to ascertain and comply with the requirements of governmental authorities having jurisdiction. In areas where no provision is made for inspection by local authorities, the applicable state regulations shall apply. Local ordinances may include wiring requirements in addition to those shown in this document or in the National Electrical Code. Consult inspection authorities for requirements, city or county permits, and inspections which may be required before service can be connected.
2. The customer should apply for service and verify the available service voltage with PG&E as far in advance of construction as possible. The customer should then notify his pump company of the available PG&E voltage.
3. Available Service Voltage: Non-residential single-phase loads to a maximum of 7-1/2 hp shall be served at 120/240 V, single-phase, 3-wire. Three-phase motors of 5 hp, but less than 30 hp, will normally be served at 120/240 V, three-phase, 4-wire, but may be served at 120/208 V or 277/480 V at the customer's option and if capacity is available from existing facilities. Single or grouped three-phase motors of 30 hp to 50 hp can be served at 120/240 V, three-phase, 4-wire, if the customer has a combination of single and three-phase loads, otherwise they must be served at 120/208 V or 277/480 V, three-phase, 4-wire. Single or grouped three-phase motors from 60 hp to 125 hp shall be served at 120/208 V or 277/480 V, three-phase, 4-wire. Three-phase motors larger than 125 hp shall be served at 277/480 V, 4-wire.
4. If one or more service posts are used to support the service conduit and metering equipment, or a panel board on which the service and metering equipment are mounted, they shall meet the minimum requirements outlined in [Document 054712](#) for service posts and [Document 065374](#) for panel board construction. Service posts can be installed for applications from 0 to 200 amps, otherwise, panel board construction is needed.



**Agricultural Underground Service 500 hp or Less****5. Service Conduit and Termination**

- A. Service termination shall be in a PG&E-approved service termination facility. Refer to Figure 5 on Page 6 through Figure 8 on Page 7 for typical installations.
  - B. In accordance with [PG&E's Electric Rule 16](#), PG&E shall install the service riser and conduit sweep at PG&E's pole, and shall pull and connect the service lateral to the customer's termination facilities. The customer shall provide and install all conduits and other substructures as necessary and shall trench from the base of PG&E's pole or customer's property line to the service termination point.
  - C. The minimum conduit size is based on the maximum continuous ampacity of the metering equipment. Refer to [Document 063928](#) to select the appropriate size and number of conduits.
  - D. Underground conduit (Item 5) is restricted to the following types:
    - (1) Hot-dip galvanized rigid steel.
    - (2) PVC, Schedule 40 or 80, UL approved 90°C.
    - (3) PVC marked ASTM F-512, DB120 or better, with prior local PG&E approval. Riser conduit (Item 7) is restricted to galvanized rigid steel.
  - E. When the conduit enters an enclosure for service termination, end bells should be installed, unless the conduit has been installed in an enclosure equipped with duct terminators. Cable protectors should be installed on reconstruction projects only, when end bells cannot be installed. Refer to [Document 062288](#) for more information about conduit fittings.
  - F. The minimum depth of the customer's underground conduit shall be 24 inches for secondary or 30 inches for primary. If the underground service is in a location subject to erosion, sub-soiling, or ripping, conduit should be buried at a depth sufficient to avoid possible damage, but not less than 24 inches.
  - G. PG&E will determine the point-of-service termination to avoid unsuitable routing of underground service installations.
6. If a pad-mounted transformer is used, the customer shall provide the transformer concrete pad. Dimensional details and additional trenching requirements will be provided by the local PG&E office.
7. The customer shall be responsible for bonding and grounding all exposed non-current carrying metal parts. Grounding shall be in accordance with National Electric Code, local ordinances, and PG&E requirements. Do not install a bonding jumper or ground wire inside of any PG&E sealed section. Bonding jumper or ground wire attachments to the outside of the meter cabinet are allowed.

**8. Metering Requirements**

- A. The meter sequence shall be meter-switch-fuse for all installations.
- B. The customer shall provide and install a self-contained meter socket or current-transformer metering enclosure, approved by PG&E, for the available service voltage, in accordance with Table 1 on Page 4 and the illustrations on Page 5.
- C. For agricultural services, the rating of the service supplied will be determined by the ampacity rating of the metering equipment or enclosure (typically, whichever is greater) where the service conductors terminate.

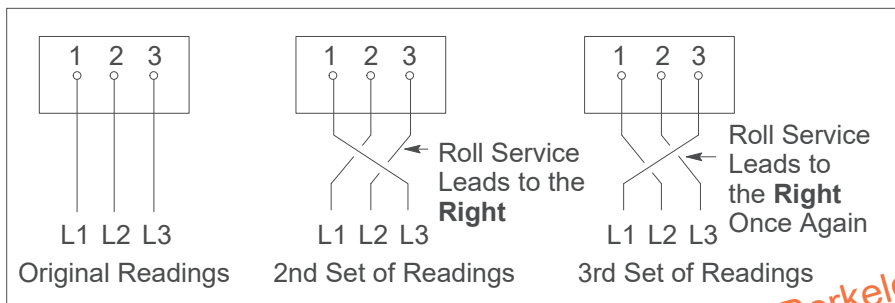
**9. Customer's Control Equipment**

- A. Customer's switch and motor control equipment may be installed on the same post or panel board as the underground service terminating and metering equipment.
- B. Customer's switch and motor control equipment shall be of proper horsepower and voltage rating and shall be weatherproof. This equipment shall include three overcurrent units, one in each phase, for protection of each three-phase motor or as otherwise specified in Article 430 of the National Electric Code.
- C. Customer's switch and motor control cover shall be effectively locked or sealed if the enclosure contains accessible electrically energized parts.

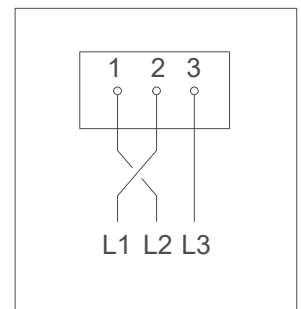
**Agricultural Underground Service 500 hp or Less**

10. Service to Three-Phase Pumps

- A. When three-phase service is established to a pump, PG&E’s crew will assist in checking for satisfactory pump motor performance if the customer or his representative is present. The construction crew should take “clamp-on” ammeter readings at the service head, or the customer or his representative can take the readings at the motor control box. If the reading on the “high” phase is more than 10% higher than the reading on the “low” phase, then the phases should be rolled to get the readings as close as possible (see Figure 1 below). The set of readings that gives the lowest difference is the connection to be retained. It is possible that none of the other readings will be any better. Record all readings.
- B. Starting and stopping of the pump should be done only by the customer or his representative. Connections can be changed at the transformer pole or service pole by PG&E’s crew or at the motor control box by the customer or his representative.
- C. On 240 V 3-wire services where one phase conductor is grounded, all rolling of leads must be done on the customer’s motor leads (at the motor control box), **not** on PG&E’s service leads.



**Figure 1**  
**Rolling Leads**  
(maintains same rotation)



**Figure 2**  
**Interchanging Leads**  
Reverses Rotation  
(for information only)

**Example:** Once water was flowing satisfactorily from the pump, the following ammeter readings were taken:

	Amps		
	L1	L2	L3
A. Original Readings	60	61	67
B. Second Set of Readings	60	62	63
C. Third Set of Readings	59	62	66

**Conclusion:** Connection “B” should be used.

11. A voltage stabilizer shall be installed in all 480 V three-phase, 3-wire ungrounded service. See [Document 052497](#).

References	Location	Document
<a href="#">Installation of Meter Protective Device on 480 V Services</a> .....	<a href="#">ELS</a> .....	<a href="#">033286</a>
<a href="#">Voltage Stabilizer for 480 Volt Three-Phase, 3-Wire, Ungrounded Service</a> .....	<a href="#">OH: Meters/EMWP</a> .....	<a href="#">052497</a>
<a href="#">Permanent Wood Post Installation Underground Electric Service</a> .....	<a href="#">UG-1: Services/Greenbook</a> .....	<a href="#">054712</a>
<a href="#">Agricultural Overhead Service 300 HP or Less</a> .....	<a href="#">OH: Services/Greenbook</a> .....	<a href="#">058087</a>
<a href="#">Underground Conduits</a> .....	<a href="#">UG-1: Conduits</a> .....	<a href="#">062288</a>
<a href="#">Methods and Requirements for Installing Commercial Underground Electric Services 0-600 Volts to Customer-Owned Facilities</a> .....	<a href="#">UG-1: Services/Greenbook</a> .....	<a href="#">063928</a>
<a href="#">Overhead and Underground Panel Board Construction</a> .....	<a href="#">OH/UG-1: Services/Greenbook</a> .....	<a href="#">065374</a>

**Agricultural Underground Service 500 hp or Less****Typical Underground Service****Table 1 Customer's Metering Equipment Requirements <sup>1</sup>**

Service Voltage <sup>2</sup>	Maximum Horsepower <sup>3</sup> Single or Grouped Motors	Metering Equipment's Current Rating (maximum amps shown) <sup>6</sup>	Type Meter Equipment Required	Refer to
120/240 Volt Single-Phase, Non-Residential, 3-Wire	7 1/2 hp Single	100	Self-Contained, 4-Jaw Bused Safety-Socket Meter Box	Figure 5, Page 6
240 Volt Delta 3-Phase, 3-Wire <sup>4</sup>	30 hp Single or Grouped	100	Self-Contained, 5-Jaw Bused Safety-Socket Meter Box	Figure 6, Page 6
	60 hp Single or Grouped	200		
240/120 Volt Delta 3-Phase, 4-Wire	30 hp Single or Grouped	100	Self-Contained 7-Jaw Bused Safety-Socket Meter Box	Figure 7, Page 6
	50 hp Single or Grouped	200		
480 Volt Delta 3-Phase, 3-Wire <sup>5</sup>	60 hp Single or Grouped	100	Self-Contained 5-Jaw Bused Safety-Socket Meter Box	Figure 6, Page 6
	125 hp Single or Grouped	200		
	300 hp Single or Grouped	400	Combination Meter, Current- Transformer, and Service Termination Cabinet with 8-Jaw Socket and CT Mounting Base	Figure 8, Page 7
277/480 Volt Wye 3-Phase, 4-Wire	60 hp Single or Grouped	100	Self-Contained 7-Jaw Bused Safety-Socket Meter Box	Figure 7, Page 6
	125 hp Single or Grouped	200		
	300 hp Single or Grouped	400	Combination Meter, Current-Transformer and Service Termination Cabinet with 13-Jaw Socket and CT Mounting Base	Figure 8, Page 7
	500 hp Single or Grouped	600	Pad-Mounted (free standing) Switchboard	<a href="#">Greenbook Section 10</a>

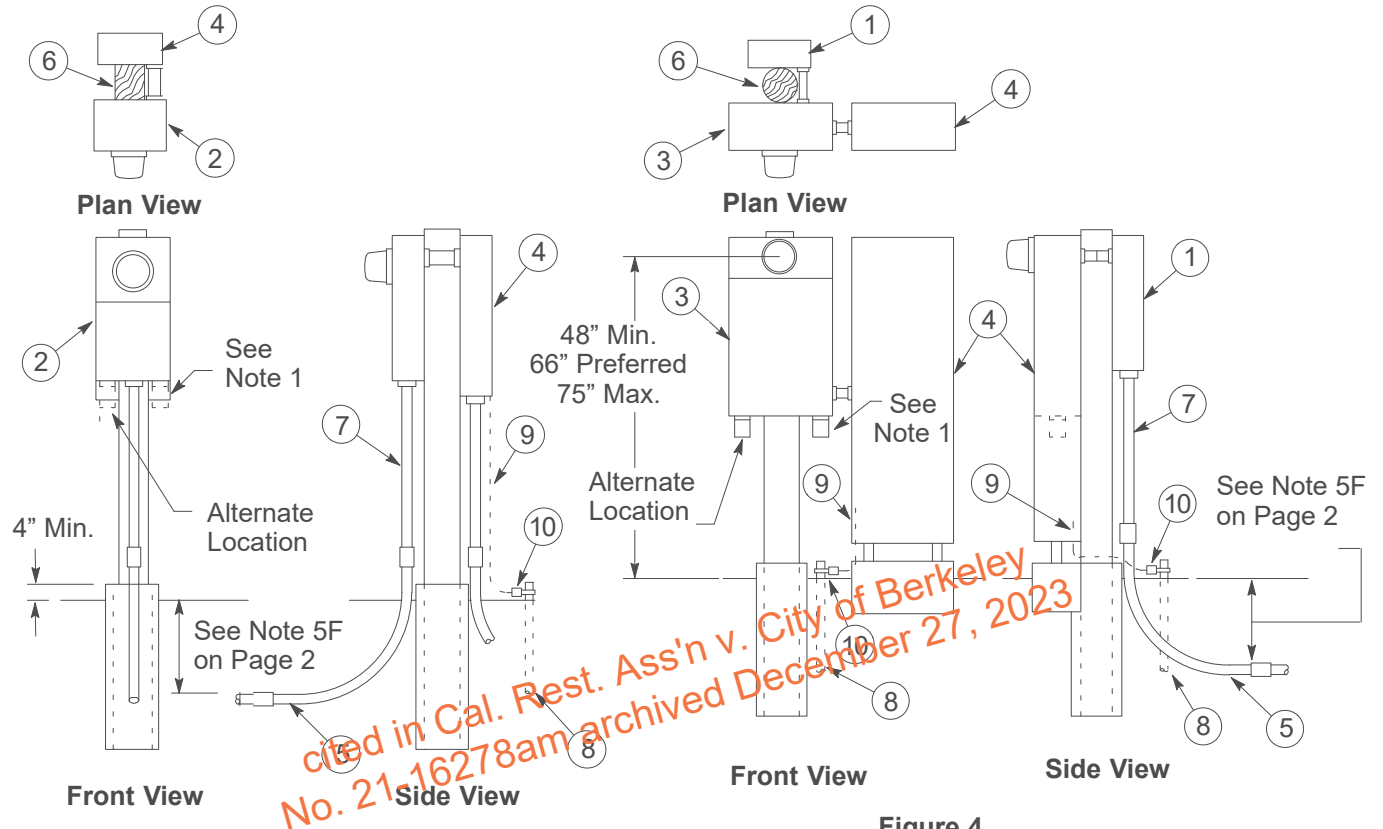
<sup>1</sup> For meter equipment illustration, see Pages 6 and 7.<sup>2</sup> See Note 3 on Page 1 for available service voltages.<sup>3</sup> Maximum horsepower for single and grouped motors is based on nameplate ratings. Ratings shown are the recommended values for motors running at full load.<sup>4</sup> Limited availability, consult PG&E.<sup>5</sup> 480 Volt Delta is not available to new services.<sup>6</sup> Customers may choose a greater current rating for their metering equipment.

**Agricultural Underground Service 500 hp or Less**

**Typical Underground Service (continued)**

**Note**

1. Voltage stabilizer shall be furnished and installed by PG&E. Refer to [Document 052497](#).



**Figure 3  
Safety Socket Box and  
Service Equipment  
Enclosure**

**Figure 4  
Meter and CT Cabinet  
With Free-Standing  
Pad-Mounted Service  
Equipment Enclosure**

**Table 2 List of Materials to Be Furnished and Installed by the Customer**

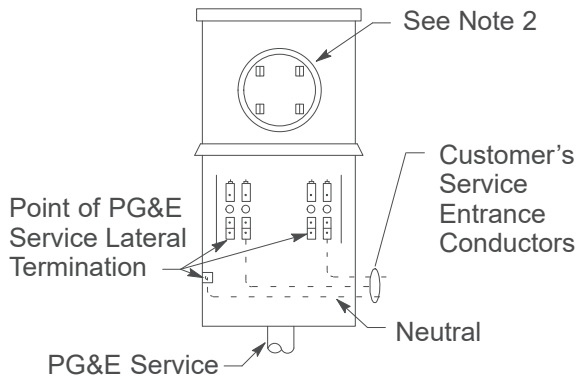
Item	Description
1	Underground Pull Box (see Figure 8 on Page 7)
2	Self-Contained Bused Safety Socket Box (see Figure 5, Figure 6, and Figure 7 on Page 6)
3	Combination Meter and Current-Transformer Cabinet
4	Main Switch or Service Equipment Enclosure
5	Service Conduit (see Note 5D on Page 2)
6	Post (see Note 4 on Page 1)
7	Conduit, Riser, Galvanized (see Note 5D on Page 2)
8	Ground Rod (see Note 7 on Page 2)
9	Ground Wire, Copper, Bare, or Armor Clad (see Note 7 on Page 2)
10	Ground Clamp, as Required, for Item 9

### Agricultural Underground Service 500 hp or Less

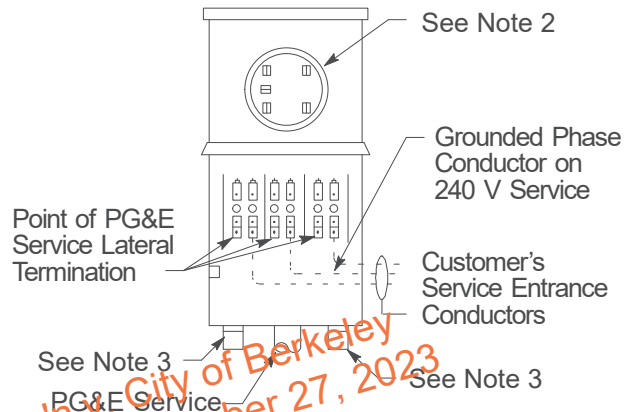
## Safety Socket Meter Boxes

### Notes

1. Applicable to maximum of 125 hp motor(s) (self-contained).
2. Refer to PG&E's [Electric and Gas Service Requirements \(Greenbook\)](#) for dimensional and specification details.
3. A voltage stabilizer, required on 480 V ungrounded services, shall be furnished and installed by PG&E. See [Document 052497](#).
4. 240 V, three-phase, 3-wire service is available only when PG&E's transformers are of the overhead type, the load is limited to three-phase motors (small 240 V, single-phase loads may be permissible in some locations), and in the future other customers are not likely to be served from the transformer bank.

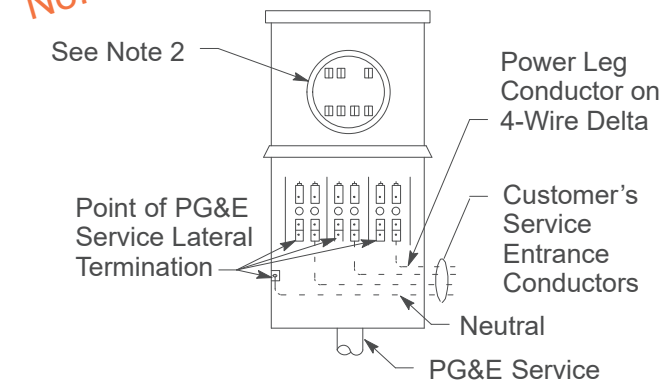


**Figure 5**  
0 - 200 Amp Safety Socket Meter Box  
120/240 V, Single-Phase, Self-Contained  
4-Jaw Bused

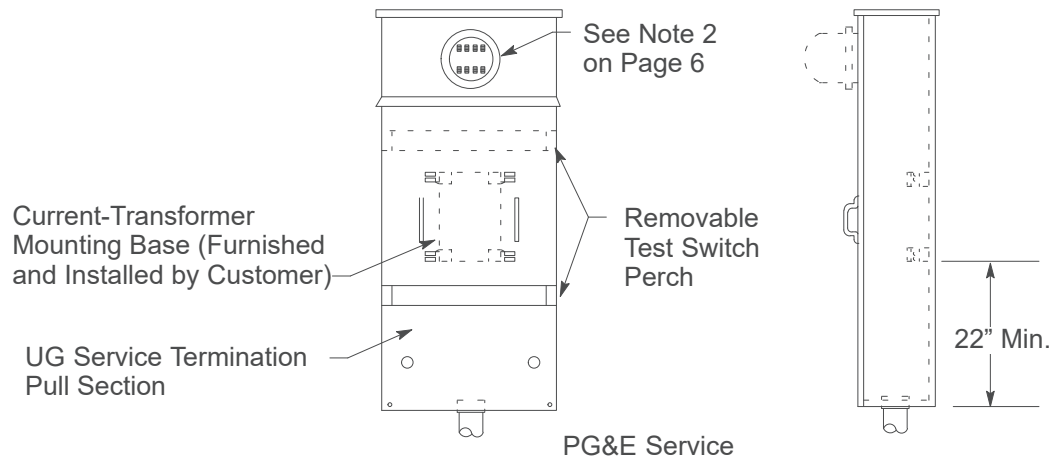


**Figure 6**  
0 - 200 Amp Safety Socket Meter Box  
240 V and 480 V, Three-Phase, 3-Wire, Self-Contained  
5-Jaw Bused (see Notes 1 and 2)

*City of Berkeley  
Rest. Ass'n v. City of Berkeley  
No. 21-16278am archived December 27, 2023*



**Figure 7**  
0 - 200 Amp, Safety Socket Meter Box  
240/120 V, Three-Phase, 4-Wire Delta  
or 480/277 V, Three-Phase, 4-Wire, Wye Self-Contained  
7-Jaw Bused (see Note 1)

**Agricultural Underground Service 500 hp or Less****Transformer-Rated Enclosures and Metering****Figure 8**

**400-Amp Service Terminating Pull Box and Combination Meter and Current-Transformer Cabinet  
240 V, Three-Phase, 3-Wire or 480 V, Three-Phase, 3-Wire Delta  
240/120 V, 3-Phase, 4-Wire Delta or 480/277 V, Three-Phase, 4-Wire Wye  
Three-Phase, 3-Wire Service Equipment is Shown (see Note 4 on Page 6)**

**Notes**


1. Applicable to maximum of 300 hp motor(s).
2. Refer to PG&E's [Electric and Gas Service Requirements \(Greenbook\)](#) for dimensional and specification details.
3. A voltage stabilizer, required on 480 V ungrounded services, shall be furnished and installed by PG&E. See [Document 052497](#).
4. 240 V, three-phase, 3-wire service is available only when PG&E's transformers are of the overhead type, the load is limited to three-phase motors (small 240 V, single-phase loads may be permissible in some locations), and in the future other customers are not likely to be served from the transformer bank.
5. Figure 8 is applicable to wall-mounted, termination enclosures with a maximum rating of 400 amps. Larger termination equipment (600 amps, three-phase) must be pad-mounted.

**Revision Notes**

Revision 10 has the following changes:

1. Corrected available service voltage for three-phase motors of 5 hp but less than 30 hp shown on Note 3 on Page 1.
2. Clarified 3<sup>rd</sup> column of Table 1 on Page 4.
3. Revised Table 1 Footnotes 3 and 6 on Page 4.

cited in Cal. Rest. Ass'n v. City of Berkeley  
No. 21-16278am archived December 27, 2023

	<b>PERMANENT WOOD POST INSTALLATION UNDERGROUND ELECTRIC SERVICE</b>	<b>054712</b>
<b>Asset Type:</b> Electric Distribution	<b>Function:</b> Construction and Design	
<b>Issued by:</b> Lisseth Villareal (LDV2) <i>Lisseth Villareal</i>	<b>Date:</b> 08-15-17	
<b>Rev. #09:</b> This document replaces PG&E Document 054712, Rev. #08. For a description of the changes, see Page 4.		

**This document is also included in the following manual:**

- [Electric and Gas Service Requirements Manual](#) (Greenbook)
- [Electric Meter Work Practices](#)

**Purpose and Scope**

This document shows the minimum requirements for a customer-installed wood post for permanent installation of underground electric service. The service installations shown on this document are intended to serve individual customers (not mobile home parks) where PG&E-approved manufactured pedestals are not readily available. Manufactured pedestals are preferred because they provide easier service installations and better protection of conduit, ground wire and customer's connection facilities.

Refer to [Electric and Gas Service Requirements Manual](#) (Greenbook), [Section 6](#) and [Section 9](#).

**General Information**

1. The customer shall install service conduit in accordance with this document. The customer shall install load side conduit and suitable conductors as required by local or state codes.
2. Local ordinances may include requirements in addition to those shown in this document. Consult local inspection authorities for these requirements. In areas where local ordinances require permits and inspection, these must be obtained before PG&E can establish service. Meters will be installed and energized by PG&E after the customer's metering equipment has been properly installed and after an inspection clearance has been given to PG&E by the appropriate electrical inspection authority.
3. When a service larger than 225 amps is desired, panel board construction is required. Refer to [Document 065374](#).
4. Service Post Installation
  - A. A permanent service installation is one which will remain for a period longer than one year, as estimated by PG&E (for temporary installations, refer to [Document 036670](#)).
  - B. Wood posts used for permanent service shall be pressure-treated for the full length. Any other process which will provide equivalent penetration and retention must be approved by PG&E. Acceptable wood preservatives are water-borne salts and pentachlorophenol. Brush application of wood preservative is ineffective for permanent posts and therefore unacceptable. Minimum dimensions of square posts shall be 6" x 6" x 8'-0" long. Minimum dimensions of cylindrical post shall be 6" diameter x 8'-0" long. Depth of setting shall be 3' 0" minimum. A 4-inch-thick concrete pad shall be poured around the post as shown in Figure 1 on Page 3 and Figure 3 on Page 4.
  - C. Post installations shall be in protected locations, out of the way of vehicular traffic or other hazardous conditions.
5. Service Conduit and Termination
  - A. PG&E will install the underground service in accordance with [PG&E's Electric Rule 16](#). The underground service lateral will be installed, owned, and maintained by PG&E from PG&E's distribution line to the termination facility, which is normally the meter enclosure.
  - B. The customer shall provide trenching and backfill in accordance with PG&E specifications and pay any costs provided for in [PG&E's Electric Rule 16](#).
  - C. Residential service will normally be installed in conduit as shown in Figure 1 on Page 3.
  - D. Non-residential service will normally be installed in conduit furnished and installed by the customer as shown in Figure 3 on Page 4.



UG-1: Services  
Greenbook  
EMWP

Permanent Wood Post Installation Underground Electric Service

6. Grounding

The customer shall be responsible for bonding and grounding all exposed non-current-carrying metal parts. Grounding shall be in accordance with the National Electric Code and local ordinances except that the grounding wire shall be protected against mechanical damage by rigid steel conduit, or armored copper ground wire may be used.

7. Metering Requirements

- A. Meters will be furnished by PG&E.
- B. For residential installations, a PG&E-approved combination service termination and meter socket panel without circuit closing devices as shown on Page 3, shall be furnished, installed, and wired by the customer.
- C. For non-residential applications, a PG&E-approved combination service termination and bused-safety-socket meter box with test bypass facilities and service main disconnect, as shown on Page 4, shall be furnished, installed, and wired by the customer.

References	Location	Document
<a href="#">Temporary Underground Electric Service Single-Phase, 120/240 Volt, 200 Amps Maximum</a>	UG-1: Services/Greenbook	036670
<a href="#">Minimum Requirements for the Design and Installation of Conduit and Insulated Cable</a>	UG-1: Cable/Greenbook	038193
<a href="#">Terminating Underground Electric Services 0-600 Volts in Customer-Owned Facilities</a>	UG-1: Services/Greenbook	058817
<a href="#">Methods and Requirements for Installing Residential Underground Electric Services 0-600 V to Customer-Owned Facilities</a>	UG-1: Services/Greenbook/EDM	063927
<a href="#">Methods and Requirements for Installing Commercial Underground Electric Services 0-600 Volts to Customer-Owned Facilities</a>	UG-1: Services/Greenbook/EDM	063928
<a href="#">Overhead and Underground Panel Board Construction</a>	Other Services/UG-1: Services/Greenbook	065374

*cited in Cal. Rest. Ass'n v. City of Berkeley No. 21-16278am archived December 27, 2023*

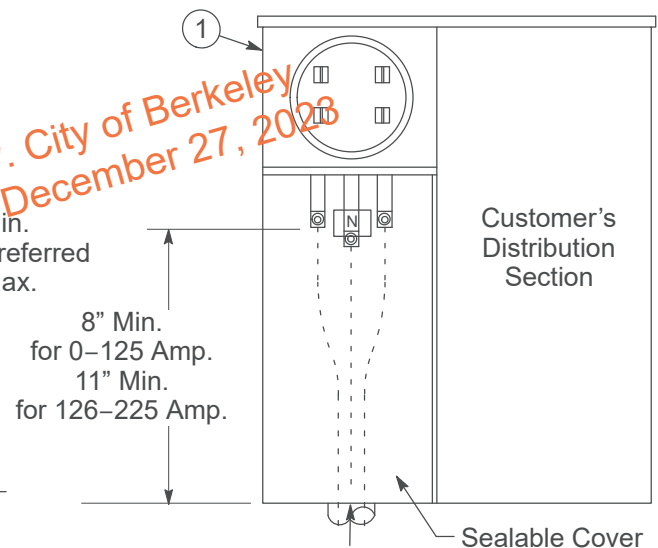
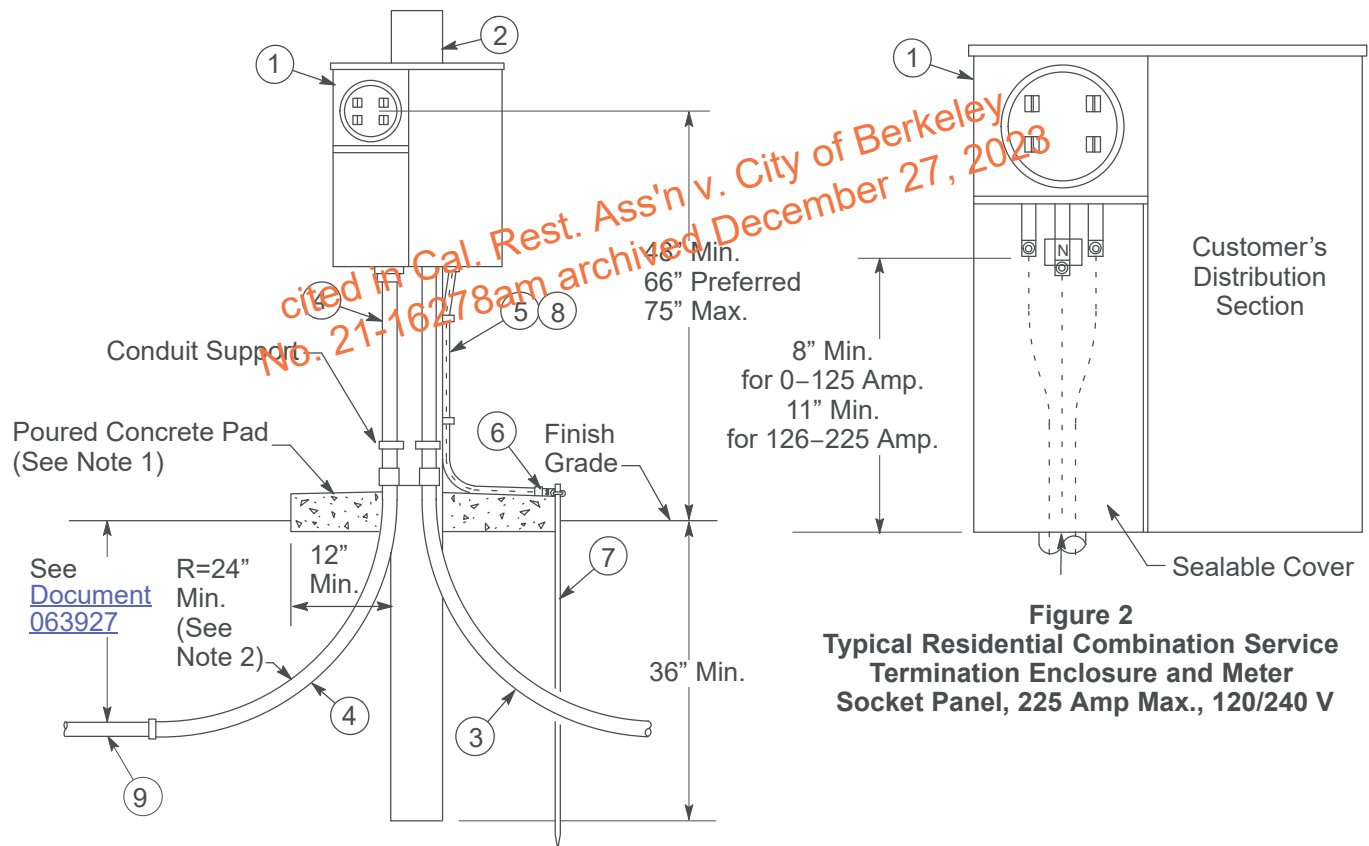
Table 1 List of Materials to be Furnished and Installed by the Customer (see Figure 1 on Page 3 and Figure 3 on Page 4)

Item	Description
1	Service Termination Enclosure, Combination Meter Socket Panel (see Figure 2 on Page 3 or Figure 4 on Page 4 for details)
2	Square Post, 6" x 6" x 8'-0" Long, Cylindrical Post, 6" in Diameter x 8'-0" Long, Fully Treated (see Note 4 on Page 1)
3	Conduit (load side), Size and Material as Required by Building Code (typically rigid galvanized steel or Schedule 80 PVC plastic)
4	Conduit, Service Riser, Rigid Steel, Galvanized or Schedule 80 PVC Plastic, (see Note 5 on Page 3)
5	Conduit, Rigid Steel, Galvanized, With Pipe Strap (for bare ground wire, omit if armor clad wire is used)
6	Hub and Clamp, Grounding, to Suit Item 5
7	Ground Rod (see Note 6)
8	Ground Wire, Copper, Bare or Armor Clad (size in accordance with applicable electrical codes and local requirements)
9	Conduit, Plastic or Rigid Steel, for Underground Service (size as shown in <a href="#">Document 063927</a> and <a href="#">Document 063928</a> )

## Permanent Wood Post Installation Underground Electric Service

UG-1: Services  
Greenbook  
EMWP**Residential Service Only, 0–225 Amp****Notes**

1. Poured concrete pad shall be approximately 4 inches thick. Provide 1/2-inch slope away from post to allow for drainage.
2. Install bend in direction of service trench. To facilitate cable installation, only one 90° bend is permitted in the service riser installation. If trench is shared with gas or other utilities, consult PG&E for required increased trench depth.
3. Meter socket enclosures for residential service (Figure 2) shall not be equipped with any circuit closing device.
4. Approved meter socket enclosures for non-residential service (Figure 4 on Page 4) shall be equipped with test bypass facilities.
5. Whenever it is necessary to install a service longer than 75 feet, the applicant must contact PG&E before ordering the service riser, conduit or, termination facilities. If the service riser and conduit called for in Table 2 on Page 4 will not accept the cable required to meet the voltage and/or flicker drop requirements, or will cause cable pulling problems, the next larger PG&E standard conduit size must be installed. (Refer to [Document 041543](#) for flicker and voltage drop requirements and [Document 038193](#) for cable pulling limitations.)



Permanent Wood Post Installation Underground Electric Service

Residential and Non-Residential Service 0-225 Amp Installed in Conduit

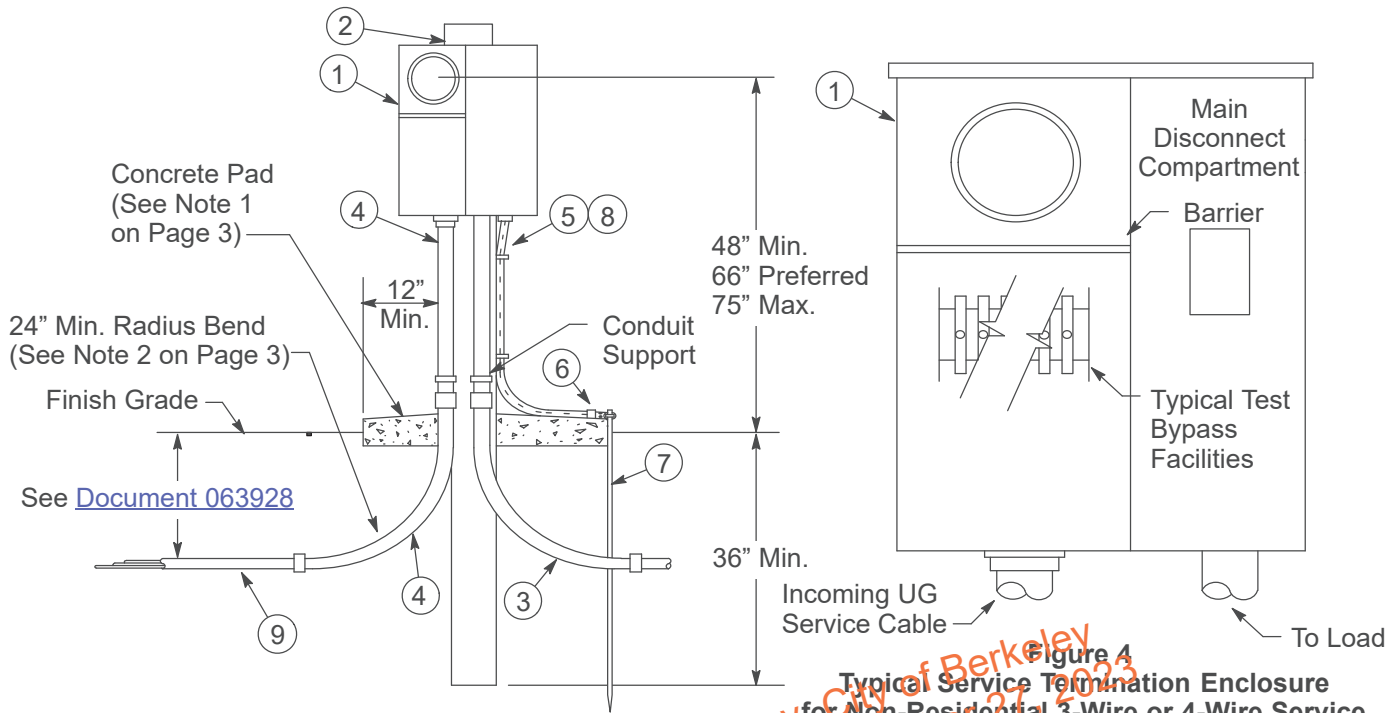


Figure 3  
Non-Residential Service

Figure 4  
Typical Service Termination Enclosure  
for Non-Residential 3-Wire or 4-Wire Service  
0-225 Amp Maximum 0-600 V  
(see Note 5 on Page 3)  
(see Figure 2 on Page 3 for typical  
residential enclosure)

Table 2 Cable and Conduit Requirements

Main Service Switch Rating – Amps	Conduit Number and Size (see Note 5 on Page 3)		Aluminum Cable Number and Size AWG or kcmil	
	3-Wire	4-Wire	Per Phase	Neutral
0-125	See Footnote <sup>1</sup>	1-3"	1-1/0	#2
126-225	1-3"	1-3"	1-4/0	1-1/0

<sup>1</sup> 1- 2" for residential. 1- 3" for non-residential.

Revision Notes

Revision 09 has the following changes:

1. Corrected Reference Location Document 036670 100 Amps to 200 Amps Maximum.



## PLANNING GUIDE FOR SINGLE CUSTOMER SUBSTATIONS SERVED FROM TRANSMISSION LINES 055103

**Department:** Electric T&D

**Section:** T&D Engineering and Technical Support

**Approved by:** G.O. Duru (GOD1)

**Date:** 01-30-06

**Rev. #01:** This document replaces PG&E Document 055103, Rev. #00. For a description of the changes, see Page 7.

### This document is also included in the following manuals:

- [Electric and Gas Service Requirements Manual](#) ("Greenbook")
- [Electric Planning Manual](#)

### Purpose and Scope

1. This document specifies the requirements and preferred method of serving single customer substations from transmission lines.
2. This substation planning guide is only applicable to single customer (PG&E owned) substations where the service delivery voltage is over 2,000 volts and the magnitude of the applicant's load is such that PG&E has elected, for its operating convenience and necessity, to supply the load from transmission sources. This will require the installation of a substation on the applicant's premises under the provisions of Section D of PG&E's Electric Rule No. 2 and Section C of PG&E's Electric Rule No. 16.
3. The applicant's service may be either overhead or underground. A typical overhead service is shown in Figure 1 on Page 5, and a typical underground service is shown in Figure 2 on Page 6. The illustrations on Pages 5 and 6 of this document are general and are intended for preliminary planning purposes only.

### General Information

4. The applicant shall, at his or her expense, obtain all land use, environmental impact, and necessary building permits.
5. It is the applicant's responsibility to install and maintain all related substation site improvements in accordance with the requirements of PG&E and those of federal, state, and local agencies.
6. The applicant shall, at his or her expense, furnish, construct, and maintain the following site improvements:
  - A. Fences and gates.
  - B. Paving and grading.
  - C. Paved access road.
  - D. Foundations, including embedded stubs and anchor bolts.
  - E. Conduits and pull boxes.
  - F. Grounding systems.
  - G. Landscaping required.
  - H. Oil retention facilities if required (as determined by PG&E or the applicant).

Foundations, underground conduits, and grounds are to be installed as specified by PG&E. The applicant shall arrange to have PG&E inspect them during installation, while they are exposed. Foundation forms and anchor bolt settings are to be approved before concrete is poured.

Landscaping or oil retention facilities may be required by local, state, or federal agencies.
7. If an enlargement of an existing customer substation is to be made that will require construction to be done within the fence of the existing energized station, it may be necessary to either relocate the fence or have the actual construction work performed by PG&E at the applicant's expense. Ties to an existing ground grid are to be made by PG&E.
8. The applicant's design for grading, access road, and oil retention facility must be approved by PG&E prior to the start of construction.

Planning Guide for Single Customer Substations Served From Transmission Lines

- 9. The applicant's service point is the terminal pad of a disconnect switch in the substation. The applicant shall terminate his or her electric service conductors with PG&E-approved flexible connectors to PG&E's copper switch pads. The connectors and tinned Everdur bolts (or equal) shall be furnished by the applicant and installed by PG&E. The applicant's equipment, except overhead service take-off lines, shall not be mounted on PG&E structures. Underground cable potheads shall be supported on a separate structure provided by the applicant.
- 10. Substation lighting poles and lighting fixtures will be furnished and installed by PG&E, including wiring. The applicant shall provide the required foundation and conduits for lighting poles as described in Note 6 on Page 1. If practical, lighting fixtures may be installed on substation structures.
- 11. Revenue metering transformers and meters will be provided and installed by PG&E. No other circuits or equipment shall be connected to the metering transformers, except with special written approval granted for unusual circumstances.

Where the applicant takes delivery at the secondary voltage level of the transformer, the applicant shall provide a cubicle which is dedicated for the installation of revenue metering transformers and meters. This metering cubicle shall be located in the applicant's switchgear, outside the fenced substation enclosure. The cubicle shall be designed to comply with PG&E's service requirement standards, and drawings shall be submitted to PG&E for approval prior to the manufacturer's fabrication.

Where the applicant takes delivery at the transmission voltage level and owns or leases the substation, metering shall normally be at the transmission voltage with the applicant providing the structures, foundation, and by-pass and disconnect switches for mounting and connecting the metering transformers. Meters shall be located in a building or cubicle provided by the applicant and accessible without entry into the fenced substation enclosure.

- 12. Services will normally be supplied from a grounded wye transformer. Services of voltages other than those shown on Table 1, are generally not available. Special consideration is necessary if 230 kV transmission voltage is required.

Table 1 Three-Phase MVA Ratings <sup>1</sup>

Nominal Transmission Voltage	Available Substation Secondary Voltage		
	4160Y/2400 V	12470Y/7200 V	21600Y/12470 V
	Three-Phase MVA Ratings (maximum)		
60 kV	0.5	12.5	12.5
70 kV	5.2	12.5	12.5
115 kV	10.5	45.0	45.0

<sup>1</sup> These ratings indicate the MVA size of emergency replacement transformers. Service to loads in excess of the values indicated requires special consideration.

- 13. The applicant shall install, adjacent to the substation, a power circuit breaker or a three-phase recloser on his or her main service conductor, or on each circuit supplied from the main service. The term "adjacent" means that only the substation fence separates the applicant's switchgear from the substation. If the applicant cannot locate his or her switchgear adjacent to the substation, the applicant shall provide a metering cubicle, and a power circuit breaker or a three-phase recloser, for his or her main service adjacent to the substation.
- 14. The applicant shall provide ground fault protection if:
  - A. Power circuit breakers or three-phase reclosers (specified in Note 13 above) serve overhead lines.
  - B. Ground fault limiting resistors or reactors are installed.

Ground fault protection is also recommended for underground cables.

The applicant's protective devices shall coordinate with PG&E's protective devices, and they shall clear every fault on the applicant's system.

- 15. Any underground conduits or piping extending outside of the fenced area of the substation yard shall be non-metallic to a distance of at least 8 feet.
- 16. On 3-wire services using metallicly shielded underground high voltage cables to connect the substation to the applicant's equipment, the cable shield should be grounded **only** at PG&E's end and shall be insulated at the applicant's end. Shielded cable shall be installed in non-metallic conduit extending to a distance of at least 8 feet outside the substation fence.

**Planning Guide for Single Customer Substations Served From Transmission Lines**

17. Where the applicant requests a ground fault limiting resistor in the transformer neutral located outside of the substation fenced area, the elevated neutral conductor shall be insulated for the operating voltage supplied. If the applicant requires a ground fault limiting resistor in the substation, the resistor and a resistor bypass switch will be installed by PG&E at applicant's expense.
18. If the applicant's equipment fence ground is bonded to his or her equipment ground grid, the fence must be separated from the substation fence by 8 feet. Use non-metallic 8-foot sections to cover the separations. If the applicant's equipment fence ground is not bonded to his or her equipment ground grid, the equipment fence must be separated from the substation fence by 6 inches.
19. The substation ground grid shall not be connected to the fence grounds or anything outside the substation. For details of ground grid installation and separation requirements of fence grounds, see [Document 067910](#) and [Document 020607](#).
20. The applicant shall be responsible for keeping the substation free of weeds and other debris.
21. The following data is to be supplied by the applicant to PG&E:
  - A. Prior to design completion:
    - (1) The applicant's service requirements, such as expected demand (MW), proposed service voltage, power factor, and ultimate growth requirements.
    - (2) Plot plan showing the proposed substation location and proposed access road.
    - (3) Grading plan of the proposed substation, access road, and adjacent areas.
    - (4) Soil report or suitable information for foundation design.
    - (5) The electrical rating of the ground fault limiting resistor, the resistor by-pass switch, current transformer, and any other associated equipment, if required by the applicant.
    - (6) Location, length, and description (overhead or underground) of the service connection to the applicant's facilities.
    - (7) Final disposition of yard drainage to determine if a special oil retention facility will be required.
    - (8) Landscaping plans, if required.
    - (9) Electrical plans, such as single line, meter, and relay drawings, general arrangement of conduits and grounds, and elementary diagrams of the applicant's facility. These drawings shall include all high voltage fuse and/or breaker ratings, capabilities of interrupting devices, current transformer and potential transformer ratios and connections, and protective relay types, ranges, and settings.
  - B. Prior to operation:
    - (1) Documentation of permits the applicant has obtained for the substation and a written inspection clearance notice from the inspection authority having jurisdiction (city, county, or state agency, etc.).
    - (2) Signed reports for the following tests:
      - (a) Phase-to-phase and phase-to-ground megger test performed on the applicant's side of the open disconnect switch to the service point, including high voltage cable runs with all customer's primary breakers and fuses racked open.
      - (b) Individual megger tests on all major equipment, such as primary breakers, potential transformers, station service and auxiliary transformers.
      - (c) Ratio test of auxiliary transformers.
    - (3) Test report showing that the primary breaker relay settings conform with the protection requirements provided by PG&E.
22. The following data is to be furnished to the applicant by PG&E:
  - A. Substation equipment layout.
  - B. Arrangement and requirements for foundations, embedded stubs, and anchor bolts.
  - C. Arrangement of conduits, if required, and grounds.
  - D. Electrical data, such as short-circuit duty, transformer impedance, etc.
  - E. Outline of PG&E's transformer bank differential current transformers to be located in the applicant's switchgear, if required.

**Planning Guide for Single Customer Substations Served From Transmission Lines**

- F. Engineering standards for substation fence and fence grounding.
- G. Requirements for revenue metering equipment.
- H. Space requirements and details of substation capacitors, if required.
- I. Provision for a mobile transformer, if required.
- J. Specification for an oil retention facility, if required.
- K. Relay coordination and other protection requirements.
- L. PG&E will prepare design drawing of the access road and fencing at the applicant's expense if the applicant so requests.

**References**

**Document**

[General Notes for Grading and Paving for Substations](#) ..... 041838

[Grounding Requirements for Outdoor Electrical Substations](#) ..... 067910

[High Pressure Sodium Outdoor Lighting](#) ..... 459076

[Method of Grounding Fences and Wire Trellises](#) ..... 020607

[Property Fence and Gates](#) ..... 059659

[Termination and Structure for 12 kV and 21 kV Underground Feeders Low Profile Substations](#) ..... 050861

**Table 2 List of Material for Serving Single Customer Substations From Transmission Lines**

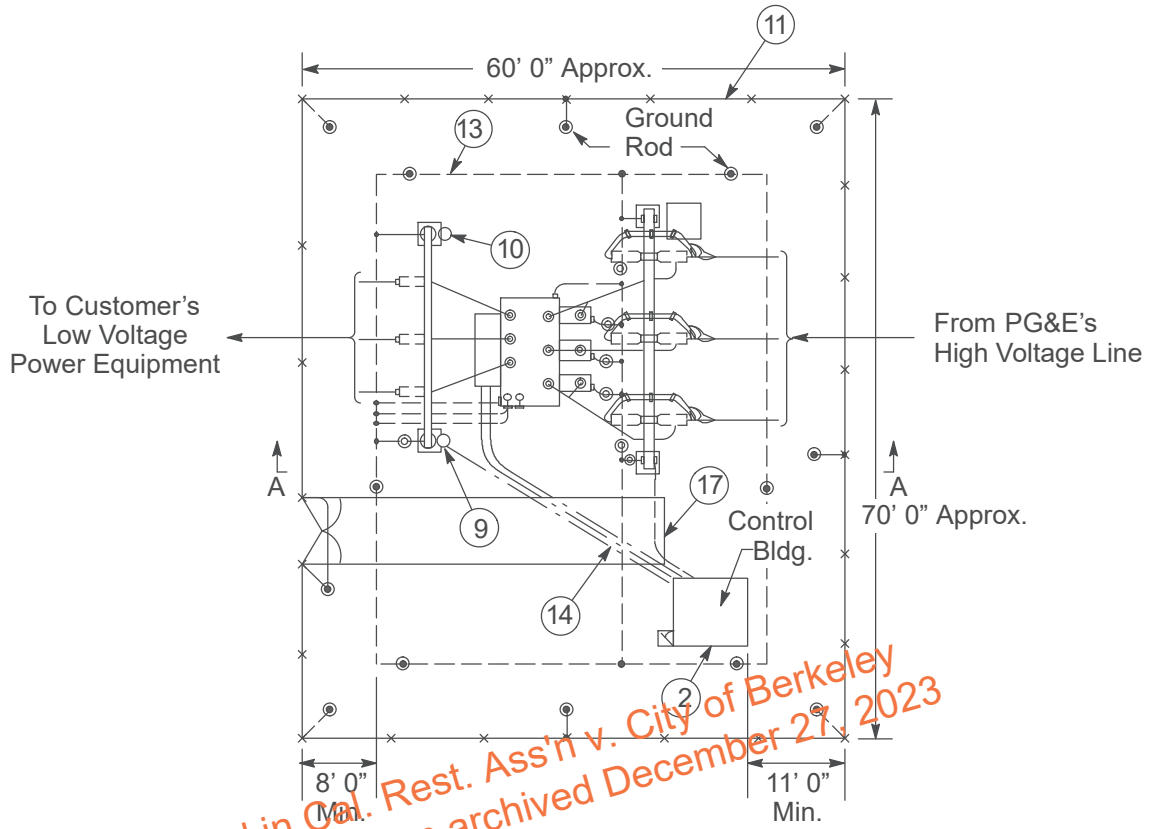
Item	Description
	Material Furnished by PG&E
1	Structures <sup>1</sup>
2	Control Building
3	Transformer
4	Control Wiring
5	Lighting Fixture
6	Air Switch
7	High Voltage Fuses
8	Disconnect Switch
9	Station Service
10	Potential Transformer
	Material Furnished by Customer
11	Fence and Gates <sup>2</sup>
12	Foundation
13	Grounding System
14	Conduits, ABS Type DB
15	Take-Off Equipment
16	Stubs and Anchor Bolts
17	Access Roads
18	Pothead and Support Structure

<sup>1</sup> Latticed steel or aluminum structures may be used instead of the tubular structures shown in Figure 1 on Page 5 and Figure 2 on Page 6.

<sup>2</sup> Gate location, roadway and inside substation arrangement may vary, depending on the direction of entry for the access road.

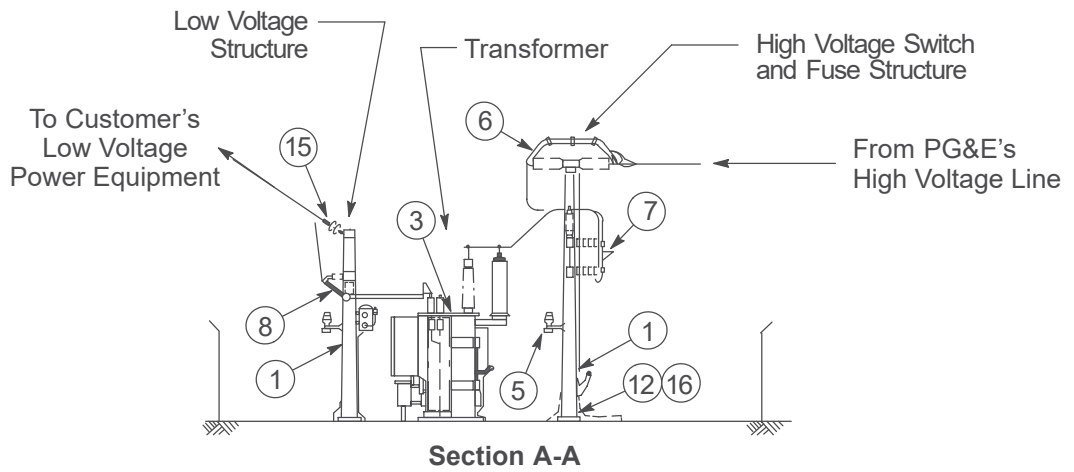
# Planning Guide for Single Customer Substations Served From Transmission Lines

## 60 or 70 kV Station for Overhead Service



*cited in Cal. Rest. Ass'n v. City of Berkeley  
No. 21-16278am archived December 27, 2023*

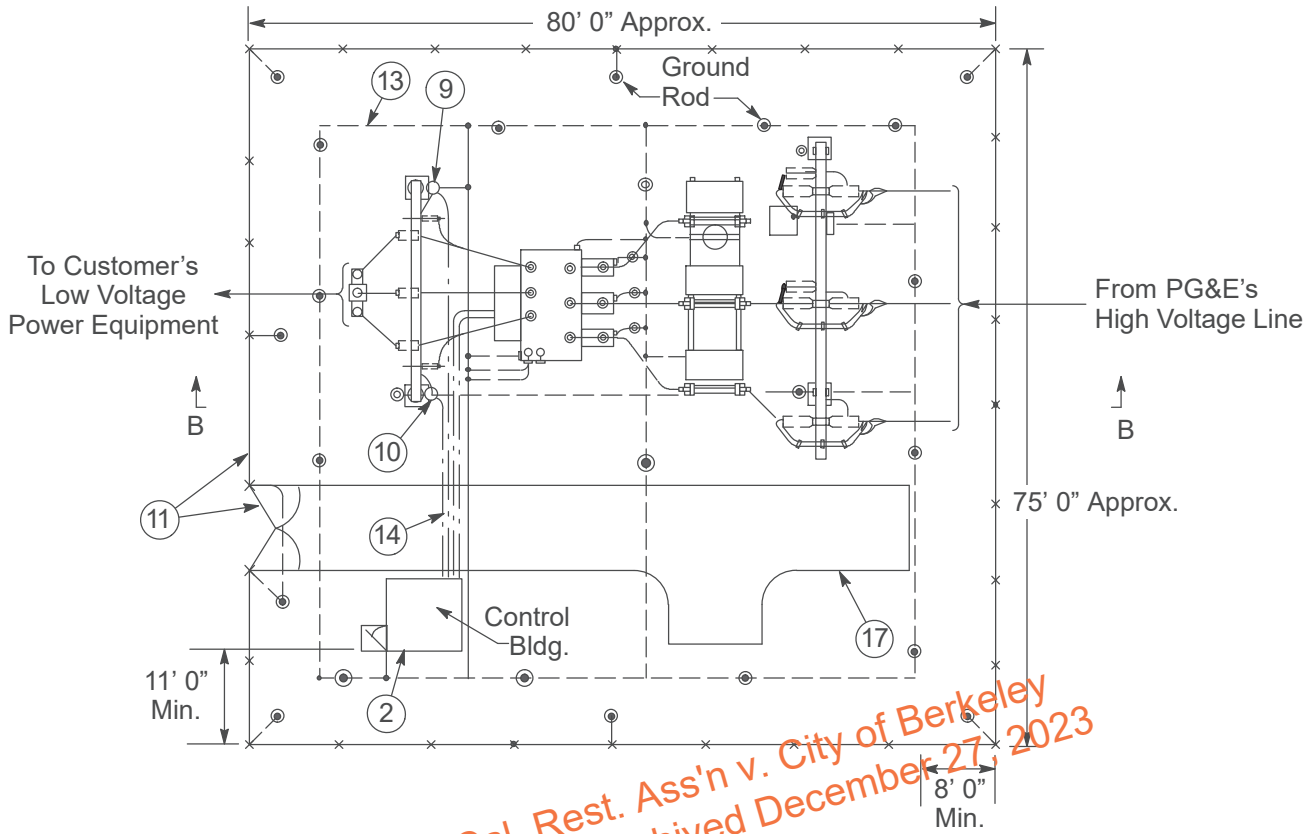
**Figure 1**  
Typical 60 or 70 kV Station for Overhead Service  
Plan View





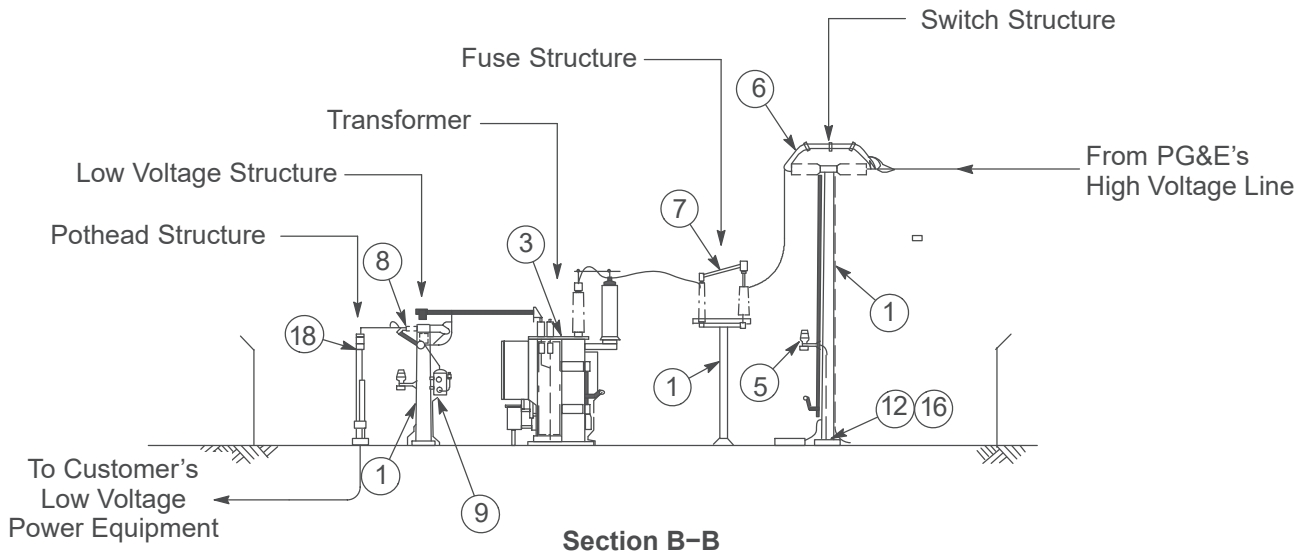
Planning Guide for Single Customer Substations Served From Transmission Lines

115 kV Station for Underground Service



*cited in Cal. Rest. Ass'n v. City of Berkeley  
No. 21-16278am archived December 27, 2023*

Figure 2  
Typical 115 kV Station for Underground Service  
Plan View



Section B-B

---

## Planning Guide for Single Customer Substations Served From Transmission Lines

---

### Revision Notes



Revision 01 has the following changes:

1. Updated the "References" section on Page 4.

*cited in Cal. Rest. Ass'n v. City of Berkeley  
No. 21-16278am archived December 27, 2023*

cited in Cal. Rest. Ass'n v. City of Berkeley  
No. 21-16278am archived December 27, 2023

Prepared by: ABB1

	<b>PAD-MOUNTED TRANSFORMER INSTALLED INDOORS</b>	<b>057521</b>
<b>Asset Type:</b> Electric Distribution	<b>Function:</b> Design and Construction	
<b>Issued by:</b> Michael Thibault (MLTC) 	<b>Date:</b> 12-01-19	
<b>Rev. #12:</b> This document replaces PG&E Document 057521, Rev. #11. For a description of the changes, see Page 20.		

**This document is also included in the following manuals:**

- [Electric and Gas Service Requirements Manual](#) (Greenbook)
- [Electric Meter Work Practices](#)

**Purpose and Scope**

This document provides a guide for determining space requirements and illustrates recommended layouts to accommodate three-phase, loop, or radial circuit, pad-mounted transformers installed in a dry room located inside or adjacent to a customer's building. The room is usually provided by the customer.

**General Information**

1. A dry room is one which:
  - A. Is located at/or above ground level, or
  - B. Is located below ground level, and
    - (1) Is completely contained within the building's foundation.
    - (2) Is so designed that flood water entry is prevented.
    - (3) Has sufficient gravity drainage to prevent water retention.
2. It is best that the doorway of the room opens to the street. However, the doors may open to a parking area or driveway provided that access is maintained from the street to the doors. The access path must be at least 11 feet wide.
3. The room must be large enough to accommodate a transformer capable of supplying 100% of the main switch capacity. Enlarging a transformer room is very costly and sometimes entirely impractical.
4. Eight feet of clear level space **must** be provided in front of the transformer cabinet, in order that the fuses and cables can be safely operated with live-line tools.
5. Ventilation design must conform to the requirements in [Document 054163](#). The location of the intake and exhaust vent shafts may be adjusted to meet local conditions. The vents shall NOT be oriented in such a manner that would allow the Intake Fan to recirculate the Hot Exhaust Air. Inside the room cross ventilation must always be maintained between the intake and exhaust. The Applicant HVAC Mechanical Engineer must prepare the calculations to PG&E with the Design Package. Service Planning and Estimating are not required to review these calculations. The calculations must have a California State Professional Engineers Stamp affixed to the calculations assuring they were prepared by a competent professional familiar with ventilation requirements identified in [Document 054163](#).
6. The room itself must conform to all applicable state and local codes. The applicant is responsible for installing and maintaining any items such as sprinklers, smoke alarms, etc. that may be required by local authorities.
7. It is preferable to have access to a room via an outside entrance which would be accessible to authorized Company employees at all times (i.e., from parking lot, loading ramp, street, etc.). However, should it become necessary to accept access through the customer's premises, arrangements should be made to ensure that complete access for both equipment and authorized Company employees is available whenever required. Inadequate access will result in prolonged outages.

## Pad-Mounted Transformer Installed Indoors

8. The room shall be designed with adequate security to permit entrance only to authorized personnel.
9. Cable troughs rather than conduits are required to allow the cables to be pulled out of the way of jacking and rolling the transformer out of the room.
10. The applicant will own and construct the transformer room and any associated substructures on its property. This provision is in accordance with the rates filed with and approved by the CPUC. The room must meet all city, county, and state codes and regulations, as well as PG&E's requirements for the safe installation, removal, and operation of its equipment.
11. PG&E must review and approve a not-for-construction drawing prior to the construction of the vault. Once approved, PG&E will forward it and the associated specification sheets to the applicant for his/her use and distribution to the general contractor. It is the responsibility of the applicant to notify PG&E of any design or construction changes. PG&E must review and approve these changes before proceeding with the design or construction of the vault.
12. It is the applicant's responsibility to contact PG&E's inspection department prior to the construction of the transformer room. PG&E will inspect the transformer room as it is being built to assure the proper installation and placement of various items required to ensure a safe working environment. PG&E equipment will not be installed until the room has been completed and the work area is clear of any debris. PG&E's inspection department must accept and sign off the room before energizing the new service. To schedule a room inspection appointment, please call \_\_\_\_\_.
13. No foreign objects shall pass through or terminate in the transformer room. The use of surface-mounted rigid electrical conduits and outlet boxes is allowed provided they are waterproof and approved by the local authorities.
14. Provide 3-hour fire rated concrete reinforced structure, including cable troughs, room walls, floor, and ceiling. Cover all exposed structural steel with 3-hour fire rated flameproof material. Seal off all openings to the interior of the building with approved caulking material. Intake and exhaust vents must be constructed with 3-hour fire dampers.
15. The doors must:
  - A. Be 3-hour fire rated.
  - B. Be capable of being secured while in the open position.
  - C. Open sufficiently so that within 2' of the 8' 6" doorway the path for the transformer installation and removal must open up to at least 11' wide.
  - D. Open sufficiently so as not to impede the sidewalk.
16. Provide a minimum of two lights with a minimum 30 foot-candle illumination. Provide convenient GFI duplex receptacles. Maintain 60 inches above the finish floor for receptacles and switches. Provide power for all equipment from the applicant's emergency power supply. Also see [Document 054438](#).
17. Provide pulling eyes (Code 36-2029) with a working load of 10,000 lbs. times a safety factor of two. Install the pulling eyes 36" above the finished floor with 4 inches of clear space between the steel and wall surface. Center them directly across from the door opening and the end of each cable trough. Submit an engineered wet stamped drawing to PG&E for its approval for any pulling eye deviations. Also see [Document 09219](#).
18. The room floor must support the total weight of PG&E equipment plus 2,000 lbs. and maintain a minimum of 10 feet ceiling height for moving the equipment.
19. A Transformer Room Agreement must be signed and recorded for an Indoor Transformer Room Installation. Reference the template at [https://sps.utility.pge.com/sites/ssenvironmental/lm/lrsupport/land\\_right\\_toolkit/land\\_document\\_templates/easement\\_document\\_templates/transformer\\_room\\_agreement.doc](https://sps.utility.pge.com/sites/ssenvironmental/lm/lrsupport/land_right_toolkit/land_document_templates/easement_document_templates/transformer_room_agreement.doc)
20. The secondary configuration depends on the main switch size and whether or not there is an associated fire pump main.
  - A. For main service of up to 7 sets of cables per Greenbook [Document 063928](#) **without** a separate fire pump service, or where the combined mains of the service and fire pump do not require more than 8 cables, the secondary are cables in an open trench to conduits stubbed through the right-side or rear vault wall (see Figure 1 on Page 5). Alternately, the cables may terminate on a wall-mounted bus stub.

**Pad-Mounted Transformer Installed Indoors**

- B. For main service of up to 7 sets of cables per Greenbook [Document 063928](#) with a separate fire pump service, the secondary is made of cables in an open trench to wall-mounted bus stubs that feed adjacent stubs to the fire pump (see Figure 4 on Page 8).
- C. For bus duct main service per Greenbook [Document 063928](#) without a separate fire pump service, the applicant provides a bus duct termination through the vault wall (see Figure 7 on Page 11).
- D. For bus duct main service per Greenbook [Document 063928](#) with a separate fire pump service, the secondary is made of cables in an applicant-installed cable tray from the side of the transformer to wall-mounted bus stubs that then also feed an adjacent bus stub to the fire pump (see Figure 9 on Page 13).
- E. The fire pump main must be dedicated to emergency equipment and must not exceed 2,000 A. With combined services, running the emergency equipment will require curtailing regular load. There shall be a permanent sign on or near the fire pump controls indicating that regular load must be curtailed when running the fire pumps.
21. Provide a \_\_\_\_\_ CFM forced air ventilation system from outside air via direct-drive, AMCA Type A or B spark resistant, fan with an explosion proof motor (intake) and high exhaust vent opening. Install 1/2-inch mesh screen on both sides of the fan assembly (see [Document 054163](#)). Install a remote thermostat sensor at the exhaust opening and a separate thermostat control 60 inches above finished floor. Set thermostat between 85°F and 90°F . All vent openings shall have a minimum of 576 square inches of opening.
22. Provide two 3/4" X 12" ground rods with 12" exposed above finished floor, as shown in the plan view. Ground rods are not to be altered in any way and must maintain a minimum of 6 feet of separation between them. Install #2 Solid CU ground wire in a loop as indicated between the ground rods. PG&E will inspect all ground rods prior to covering. Provide tests and documentation for deviations to this procedure to substantiate the resistivity of the ground rods (see [Document 060462](#)).
23. Provide a 6-inch removable sill across all entrances for oil containment after transformer(s) are installed. Caulk all gaps leading to the interior of the building. Provide a Corbin lock set with tumbler (CL3357-N2D-626 or CK4257-GRC-626) for the vault door(s). PG&E will key the tumblers. Provide provisions to lock the door in the open position for emergency purposes.
24. All exposed metal in the vault must be grounded.
25. Room to be designed and built as a Class 1, Zone 1, reference California Subchapter 5, Electrical Safety Orders, Article 59, hazardous (classified) locations.

References	Location	Document
<a href="#">Draw Bolt for Electric Manholes</a> .....	<a href="#">ELS</a> .....	<a href="#">09219</a>
<a href="#">Corrosion Resistant Ground Rods and Ground Rod Clamps</a> .....	<a href="#">UG-1: Connectors/Greenbook</a> .....	<a href="#">013109</a>
<a href="#">Connectors for Insulated Cables Underground Distribution Systems</a> .....	<a href="#">UG-1: Connectors/Greenbook</a> .....	<a href="#">015251</a>
<a href="#">Cable Support for Underground Use</a> .....	<a href="#">UG-1 Splices</a> .....	<a href="#">028077</a>
<a href="#">Tags for Identifying Underground Cables and Equipment</a> .....	<a href="#">UG-1: Marking</a> .....	<a href="#">033582</a>
<a href="#">Premolded 200-Amp Terminations for Primary Underground Cable</a> .....	<a href="#">UG-1: Terminations</a> .....	<a href="#">035314</a>
<a href="#">Cables for Underground Distribution</a> .....	<a href="#">UG-1: Cable</a> .....	<a href="#">039955</a>
<a href="#">Service Entrance from Underground Vault Using Bus Bars</a> .....	<a href="#">UG-2: Transformers</a> .....	<a href="#">041352</a>
<a href="#">Loop-Style, Three-Phase, Pad-Mounted Transformers Installation of Loop-Style, Three-Phase, Pad-Mounted Transformers</a> .....	<a href="#">UG-1: Transformers/EMWP</a> .....	<a href="#">045290</a>
<a href="#">Concrete Pad for Three-Phase, Loop-Style, Pad-Mounted Transformers</a> .....	<a href="#">UG-1: Transformers</a> .....	<a href="#">045291</a>
<a href="#">Ventilation of Vaults and Manholes</a> .....	<a href="#">UG-1: Transformers/Greenbook</a> .....	<a href="#">045292</a>
<a href="#">Installation of Wiring for Lighting and Auxiliary Equipment in Vaults and Manholes</a> .....	<a href="#">TIL</a> .....	<a href="#">054163</a>
	<a href="#">UG-2: Enclosures</a> .....	<a href="#">054438</a>

UG-1: Transformers  
Greenbook  
EMWP

## Pad-Mounted Transformer Installed Indoors

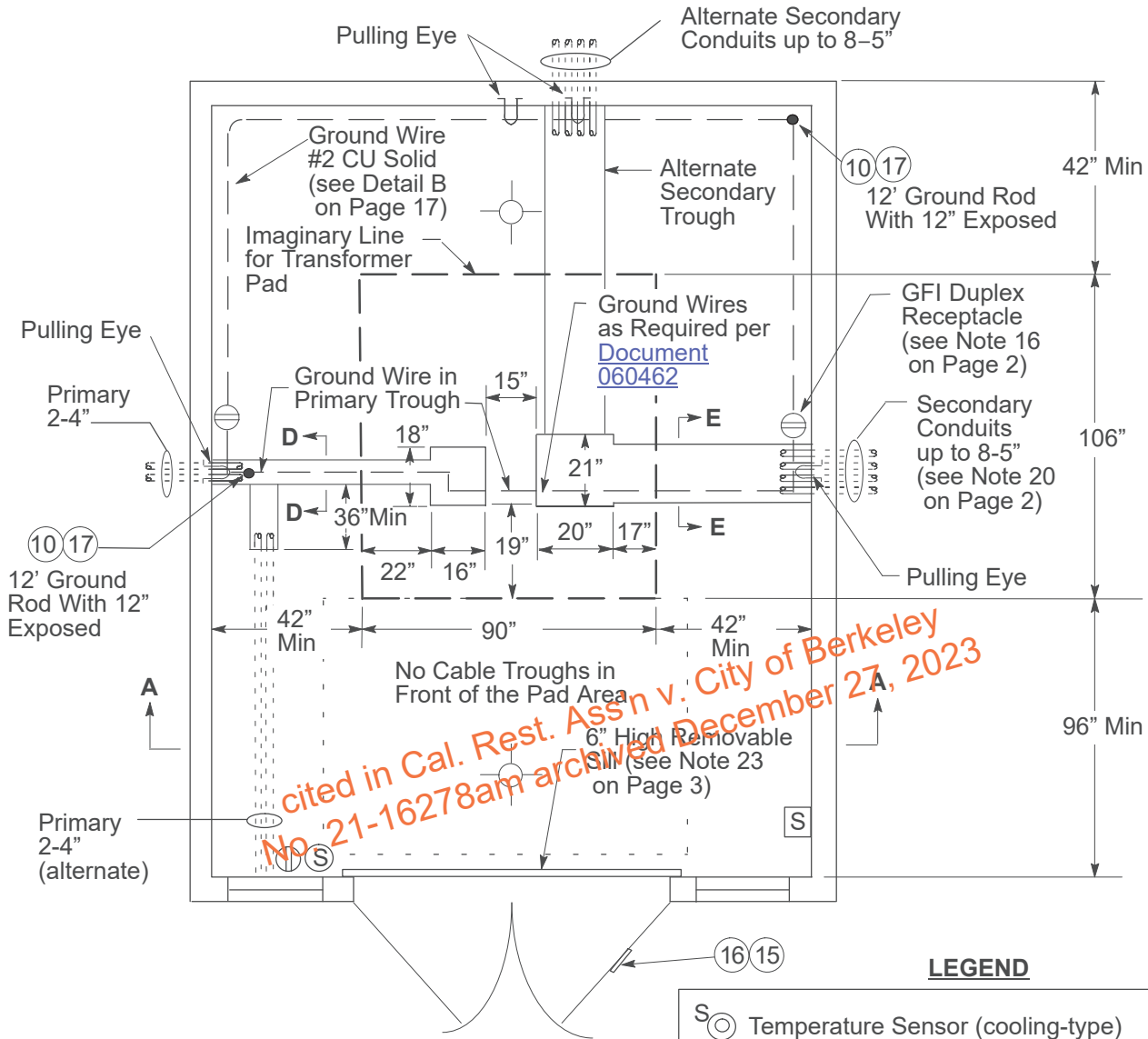
References (continued)	Location	Document
<a href="#">Terminating Underground Electric Services</a>		
0-600 Volts in Customer-Owned Facilities	UG-1 Services/Greenbook/EMWP	058817
<a href="#">Grounding of Underground Equipment</a>	UG-1: General	060462
<a href="#">Fault Indicators for Underground Application</a>	UG-1: General	061683
<a href="#">Underground Conduits</a>	UG-1: Conduits	062288
<a href="#">Methods and Requirements for Installing</a>		
Commercial Underground Electric Services		
0-600 Volts to Customer-Owned Facilities	UG-1: Services/Greenbook	063928
<a href="#">Requirements for Bus Duct Entrance Termination</a>		
Unit for Use With Pad-Mounted Transformers	UG-1: Services/Greenbook	063929
<a href="#">Corporation Padlock</a>	TIL	068200
<a href="https://sps.utility.pge.com/sites/ssenvironmental/Im/Irsupport/land_right_toolkit/land_document_templates/easement_document_templates/transformer_room_agreement.doc">https://sps.utility.pge.com/sites/ssenvironmental/Im/Irsupport/land_right_toolkit/land_document_templates/easement_document_templates/transformer_room_agreement.doc</a>		

**Table 1 Bill of Materials for Three-Phase, Pad-Mounted Transformer**

Item	Description	Code	Document
1	Transformer, Pad-Mounted, Three-Phase (as required)	-	<a href="#">045290</a>
2	Cable, Insulated, Single-Conductor, Primary, 1/0 Minimum	-	<a href="#">039955</a>
3	Cable, Insulated, Single-Conductor, 600 V (size as required)	-	<a href="#">039955</a>
4	Conduit (size as required) (by applicant)	-	<a href="#">062288</a>
5	Ventilating Fan (as required) (by applicant)	-	<a href="#">054163</a>
6	Lighting (as required) (by applicant)	-	<a href="#">054438</a>
7	Wire, Ground, Number 2 AWG Solid, Bare Copper (by applicant)	290074	-
8	Terminal Connector, Compression-Type	-	<a href="#">015251</a>
9	Connector, Ground Terminal	303214	
10	Clamp, Ground Rod, 3/4"	187017	<a href="#">013109</a>
11	Anchor Bolt, 3-1/2" x 1/2"	190445	-
12	Padlock, Corporation (for exterior locking)	016583	<a href="#">068200</a>
13	Cable Sectionalizing Tag	-	
14	Phase Description Tag	-	
15	High Voltage/Maintain 8' Clearance Label	621599	<a href="#">033582</a>
16	Transformer Number Decal	-	
17	Ground Rod, 3/4" x 12' (by applicant)	010098	<a href="#">013109</a>
18	Grating, Steel, Removable, Non-Skid (see Detail D on Page 18) (by applicant)	-	-
19	Duct Spacers (see Detail C on Page 18) (by applicant)	-	-
20	Insulated Bushing Well Plug	300486	<a href="#">035314</a>
21	Spare Concentric Wire	-	-
22	Connector, Ground Terminal	302314	-
23	200-Amp Primary Termination: Load-Break or Dead-Break Elbow Receptacles	-	
24	200-Amp Bushing Insert: Load-Break (300481) or Dead-Break (303920)	-	<a href="#">035314</a>

Pad-Mounted Transformer Installed Indoors

Layout for Up to 7 Service Cables



**Figure 1**  
Dry Vault – Plan View  
For Up to 8 Sets of Service Cables  
(see Note 20 on Page 2)

LEGEND	
$\odot$ S	Temperature Sensor (cooling-type)
$\odot$ T	Thermostat Control (60" above finished floor)
$\square$ S	Fan Cutoff Switch (60' above finished floor)
$\ominus$	GFI Duplex Receptacles (60" above finished floor)
$\odot$ S	Light Switch (60" above finished floor)
•	3/4" x 12" Ground Rod
$\odot$	Light Fixtures
U	Pulling Eye (see Note 17 on Page 2)

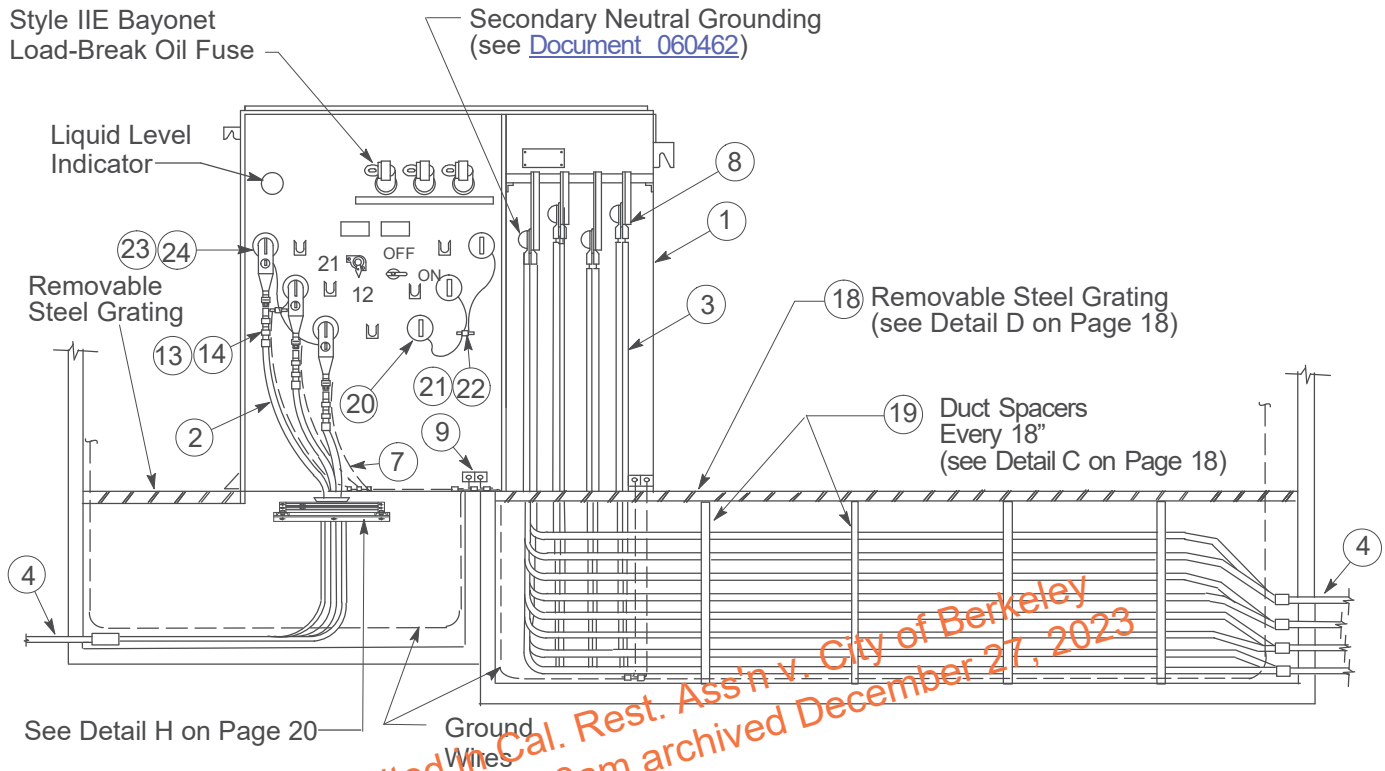
Note

1. Primary may also be routed to back wall of vault. Primary may not be routed from primary section of transformer to the back wall underneath the transformer.



Pad-Mounted Transformer Installed Indoors

Layout for Up to 7 Service Cables (continued)



*cited in Cal. Rest. Ass'n v. City of Berkeley  
No. 21-16278am archived December 27, 2023*

Section A-A

Figure 2  
Transformer Installed  
Front View  
For Up to 8 Sets of Service Cables  
(radial primary installation shown)

Pad-Mounted Transformer Installed Indoors

Layout for Up to 7 Service Cables (continued)

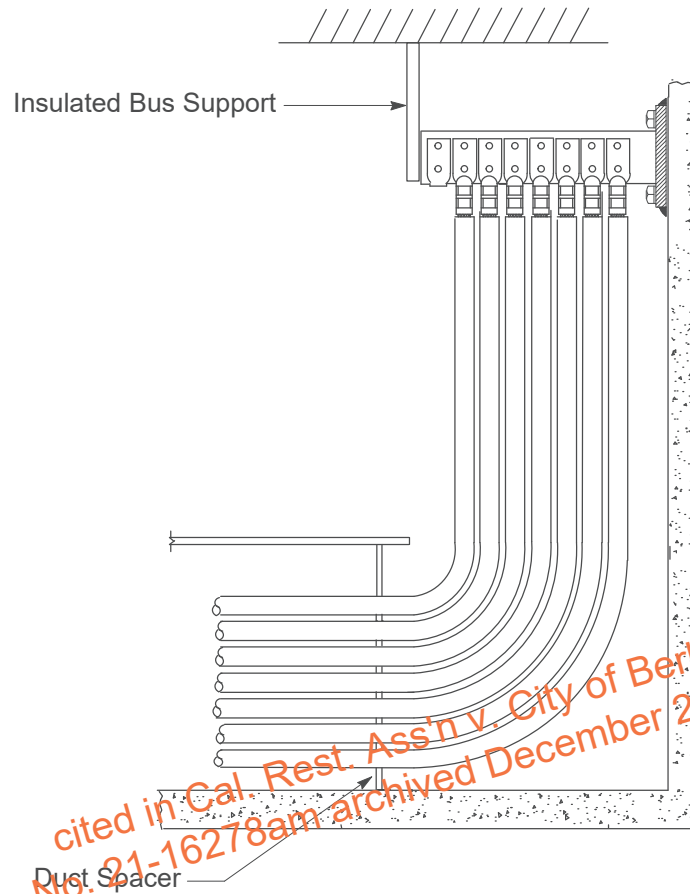
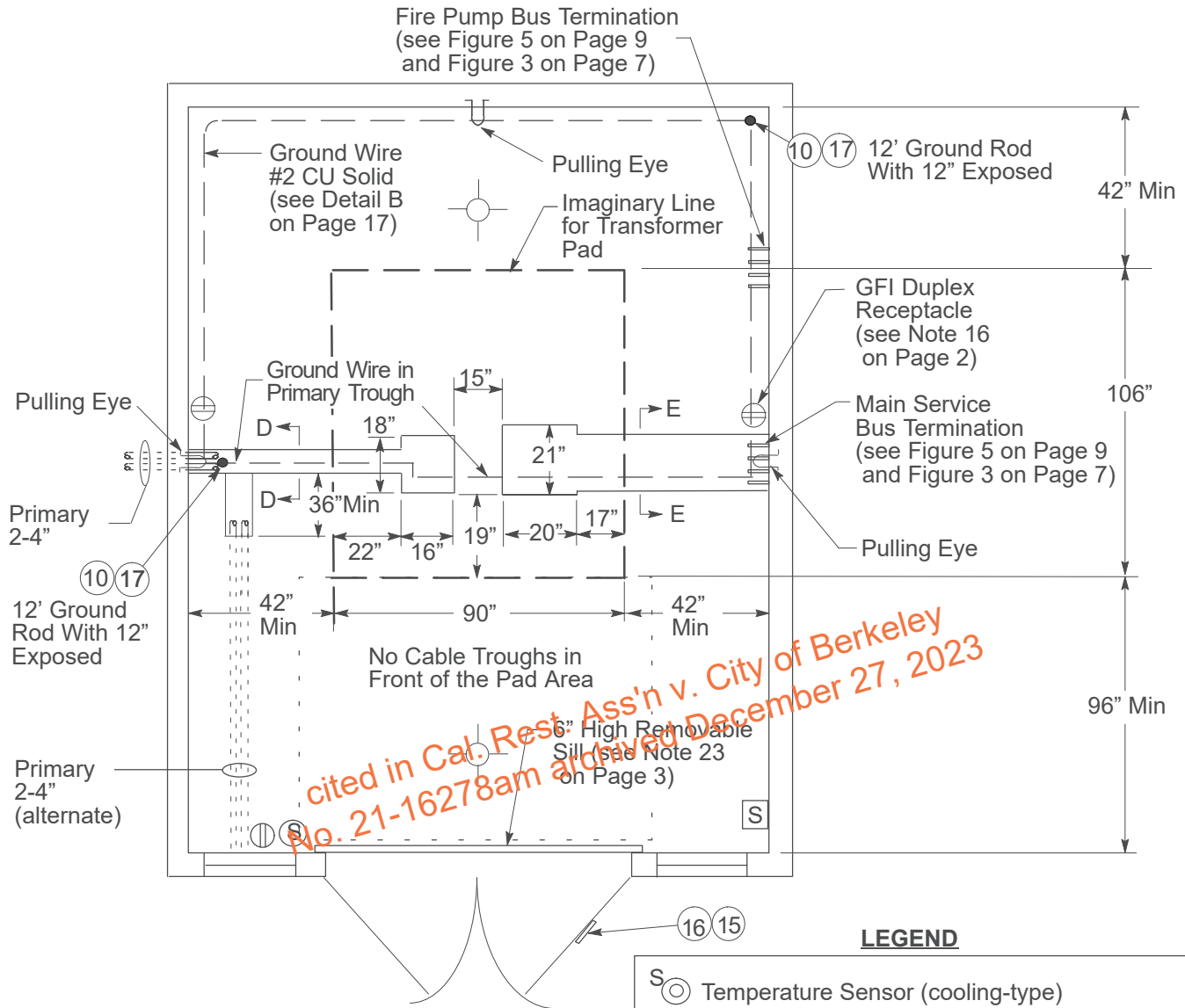


Figure 3  
Alternate Secondary Cable Trench End for Bus Duct Termination  
Side View  
(see Details D, E, F on Page 19)

Pad-Mounted Transformer Installed Indoors

Layout for up to 8 Service Cables with Separate Fire Pump



**Figure 4**  
**Dry Vault – Plan View**  
**For Main Service of Up to 7 Sets of**  
**Cables With Separate Fire Pump Service**  
(see Note 20 on Page 2)

**LEGEND**

S	Temperature Sensor (cooling-type)
T	Thermostat Control (60" above finished floor)
S	Fan Cutoff Switch (60' above finished floor)
⊖	GFI Duplex Receptacles (60" above finished floor)
Ⓢ	Light Switch (60" above finished floor)
•	3/4" x 12" Ground Rod
⊙	Light Fixtures
U	Pulling Eye (see Note 17 on Page 2)

Notes

1. Primary may also be routed to back wall of vault. Primary may not be routed from primary section of transformer to the back wall underneath the transformer.
2. All exposed grounded metal bolts within 10" of bus bars shall be suitably insulated.
3. Barrier is not needed if firestop supports the bus and is smoke proof.

Pad-Mounted Transformer Installed Indoors

Layout for up to 8 Service Cables with Separate Fire Pump (continued)

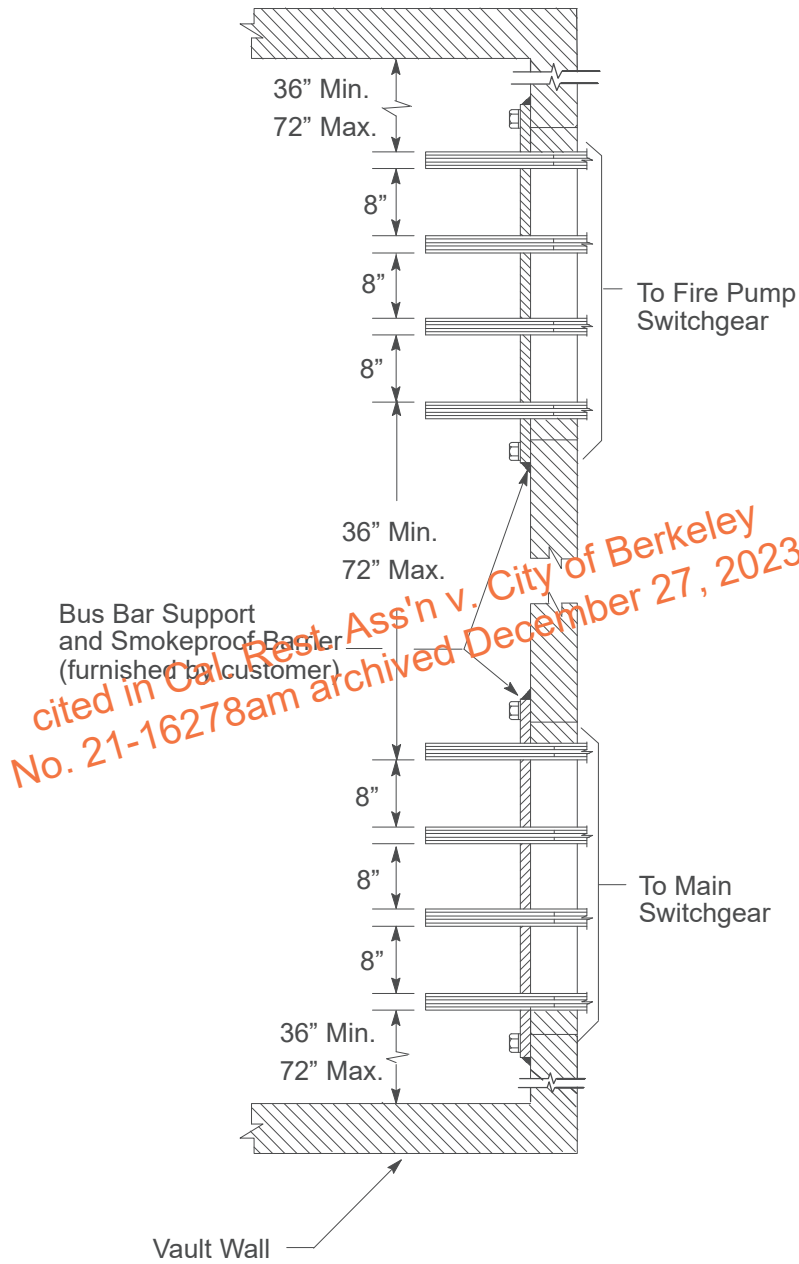


Figure 5  
Service Connection – Top View  
(see Details D, E, F on Page 19)

Pad-Mounted Transformer Installed Indoors

Layout for up to 8 Service Cables with Separate Fire Pump (continued)

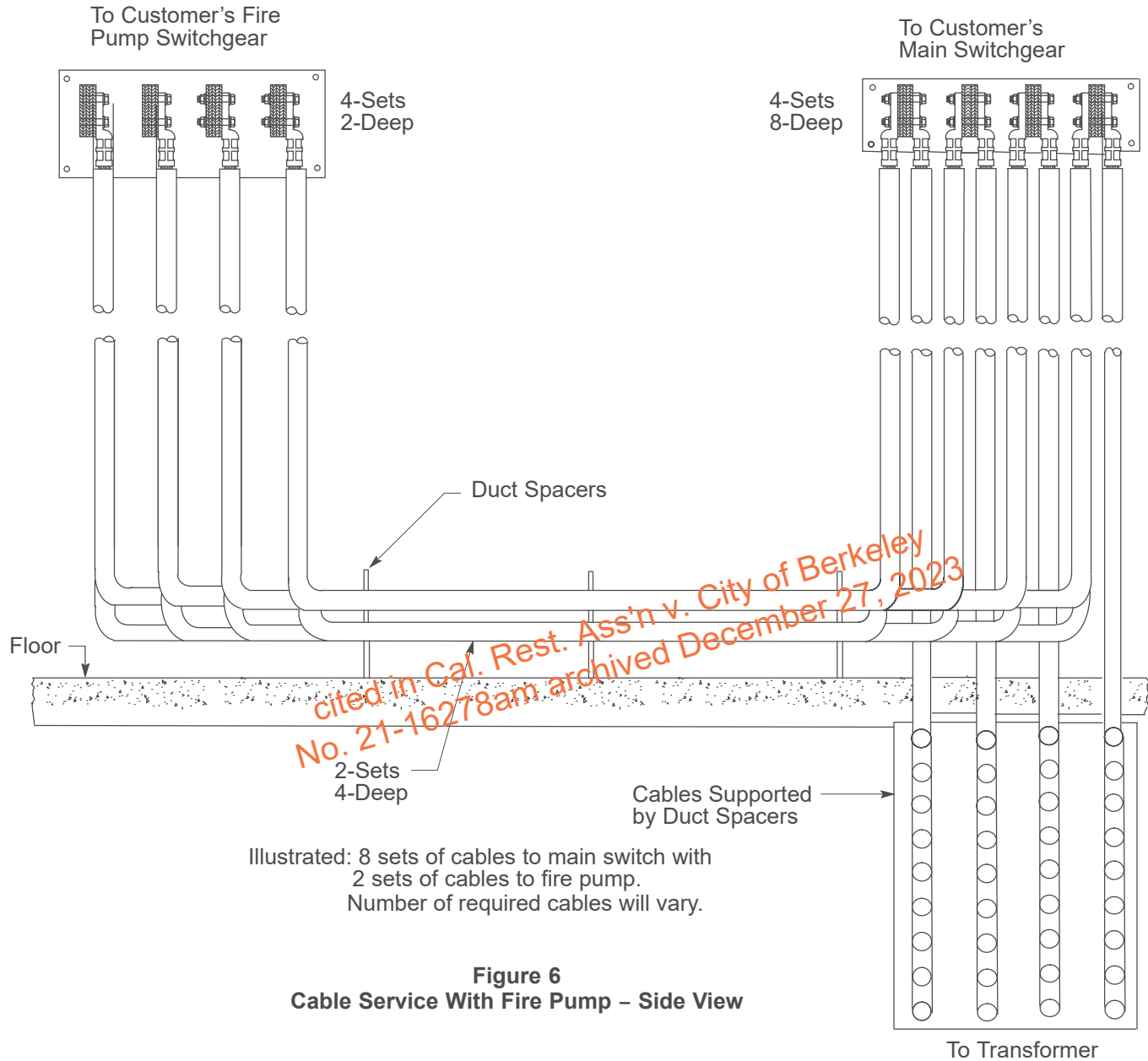


Figure 6  
Cable Service With Fire Pump – Side View

Pad-Mounted Transformer Installed Indoors

Layout for Bus Duct with no Separate Fire Pump

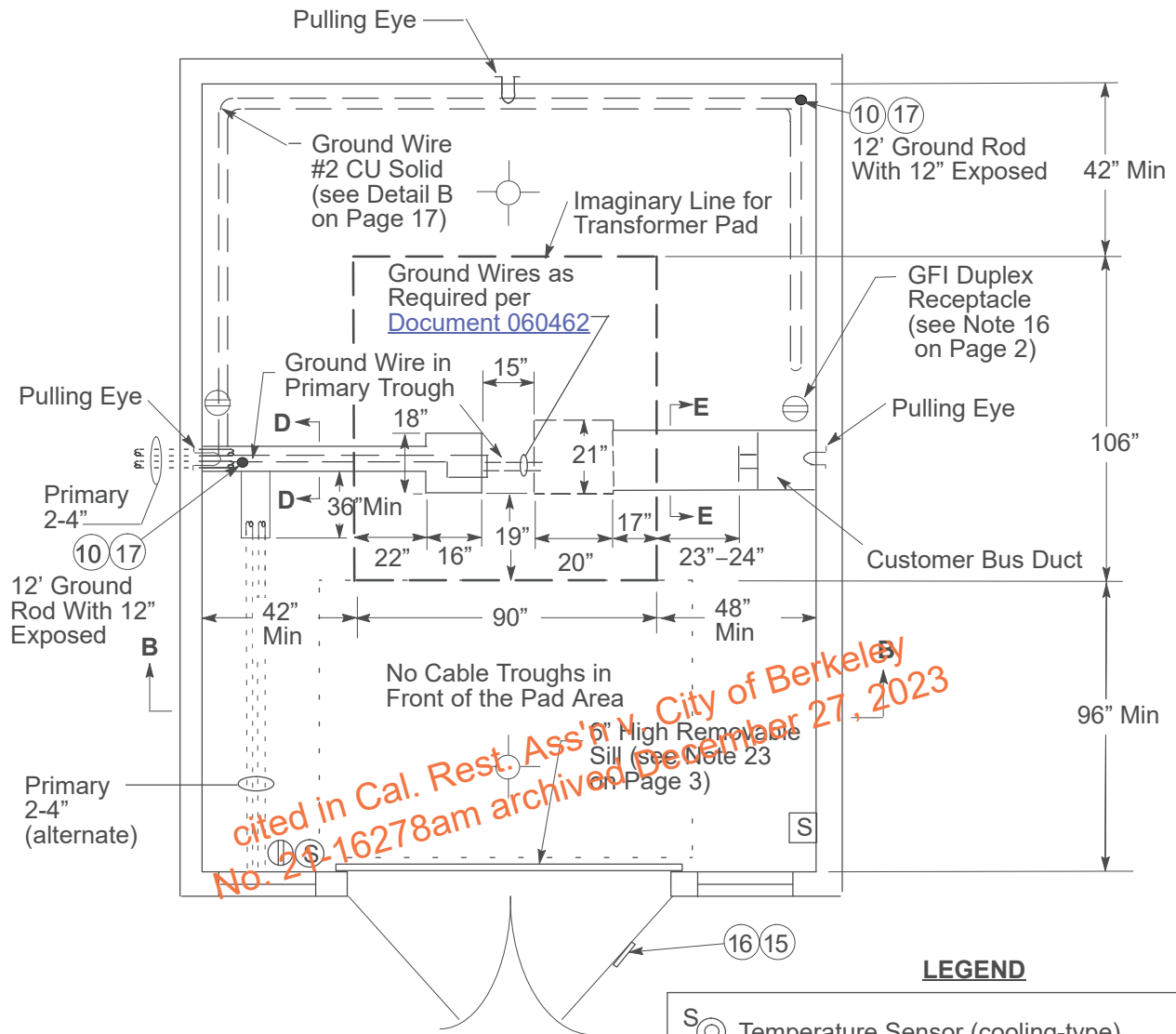


Figure 7  
Dry Vault - Plan View  
Bus Duct Main Service

LEGEND

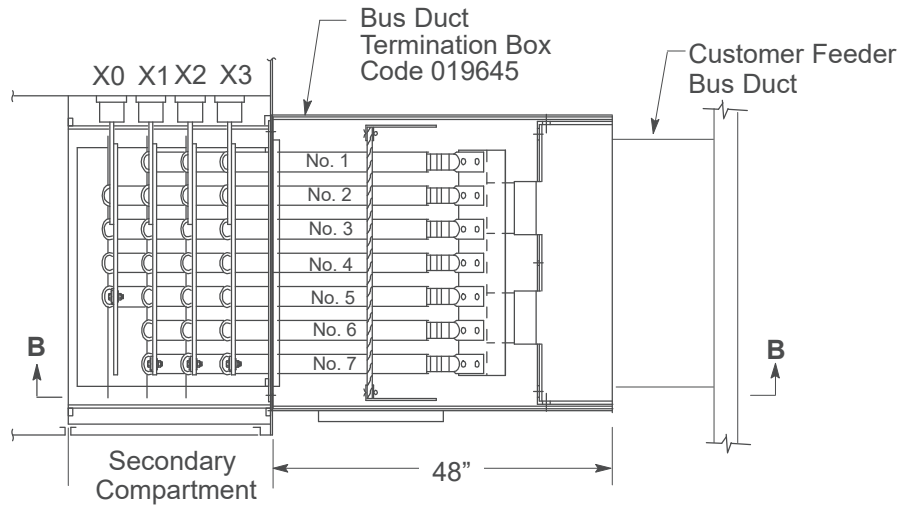
	Temperature Sensor (cooling-type)
	Thermostat Control (60" above finished floor)
	Fan Cutoff Switch (60' above finished floor)
	GFI Duplex Receptacles (60" above finished floor)
	Light Switch (60" above finished floor)
	3/4" x 12" Ground Rod
	Light Fixtures
	Pulling Eye (see Note 17 on Page 2)

Note

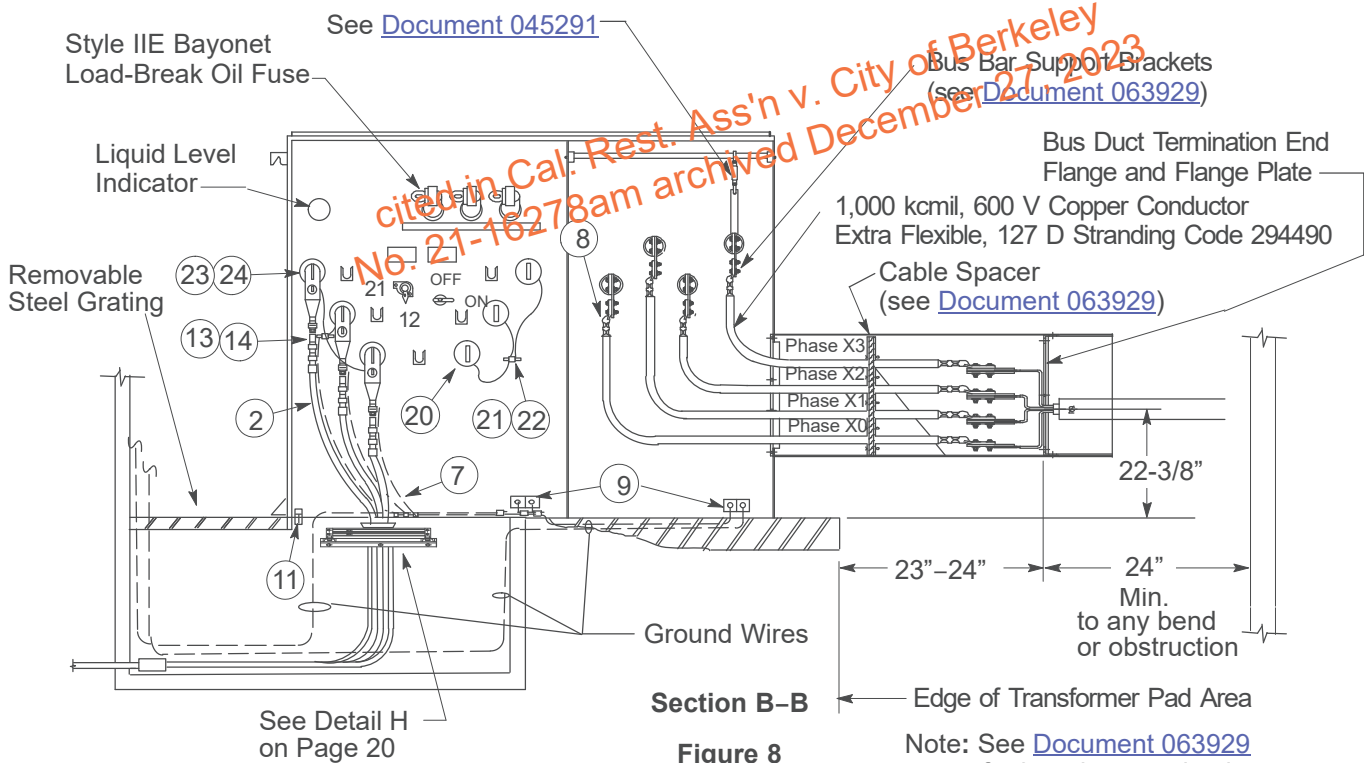
1. Primary may also be routed to back wall of vault. Primary may not be routed from primary section of transformer to the back wall underneath the transformer.

### Pad-Mounted Transformer Installed Indoors

#### Layout for Bus Duct with no Separate Fire Pump (continued)



**Detail A**  
**Top View - Bus Termination**

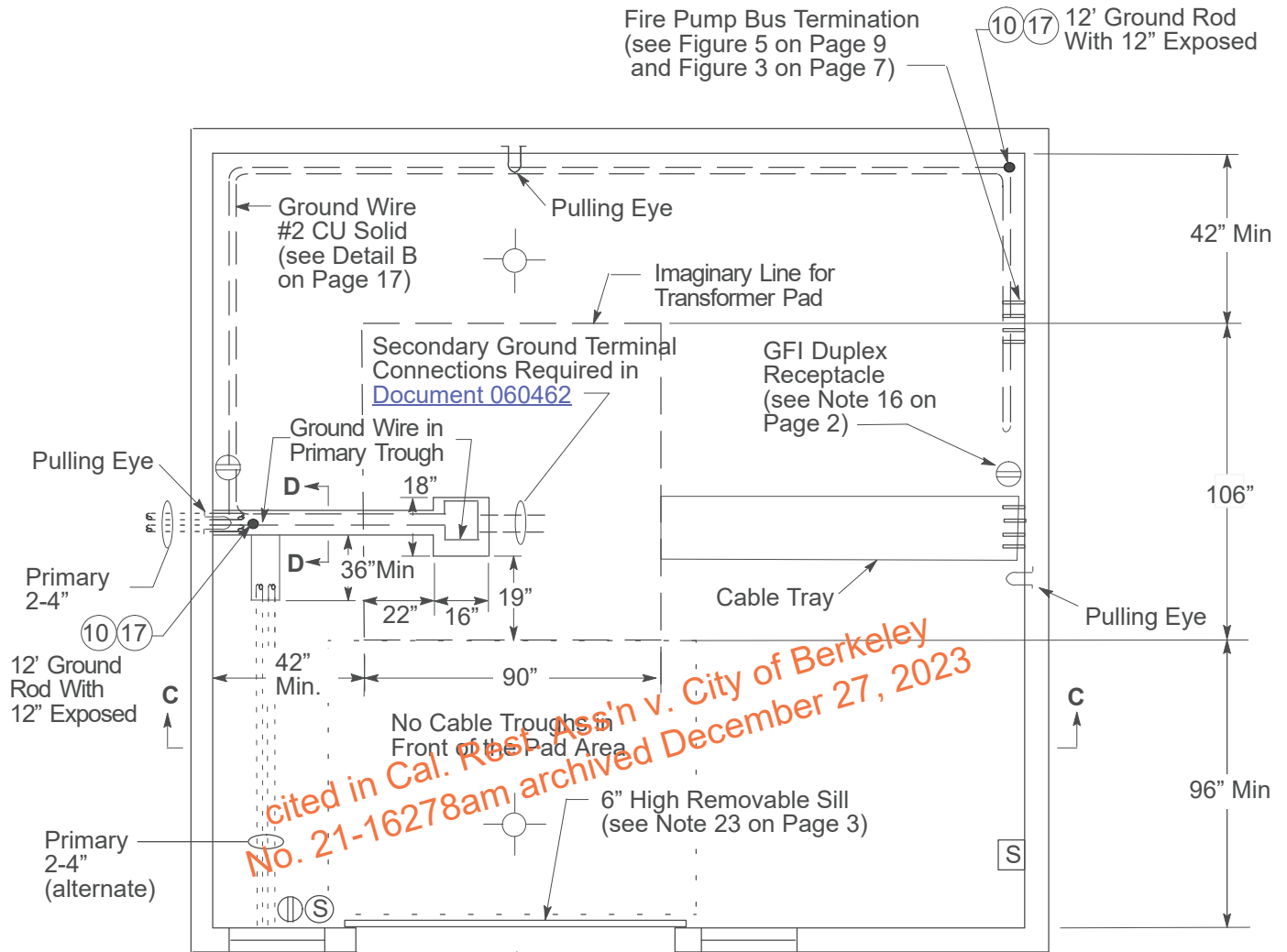


**Figure 8**  
**Bus Duct Termination**

Note: See [Document 063929](#) for bus duct termination box details

Pad-Mounted Transformer Installed Indoors

Layout for Cable Tray Service with a Separate Fire Pump



*cited in Cal. Res. Ass'n v. City of Berkeley  
No. 21-16278am archived December 27, 2023*

**Figure 9**  
Dry Vault – Plan View  
Bus Duct Main Service  
With Fire Pump

**LEGEND**

$\odot$	Temperature Sensor (cooling-type)
$\odot$	Thermostat Control (60" above finished floor)
$\square$	Fan Cutoff Switch (60' above finished floor)
$\ominus$	GFI Duplex Receptacles (60" above finished floor)
$\odot$	Light Switch (60" above finished floor)
$\bullet$	3/4" x 12" Ground Rod
$\circ$	Light Fixtures
$\cup$	Pulling Eye (see Note 17 on Page 2)

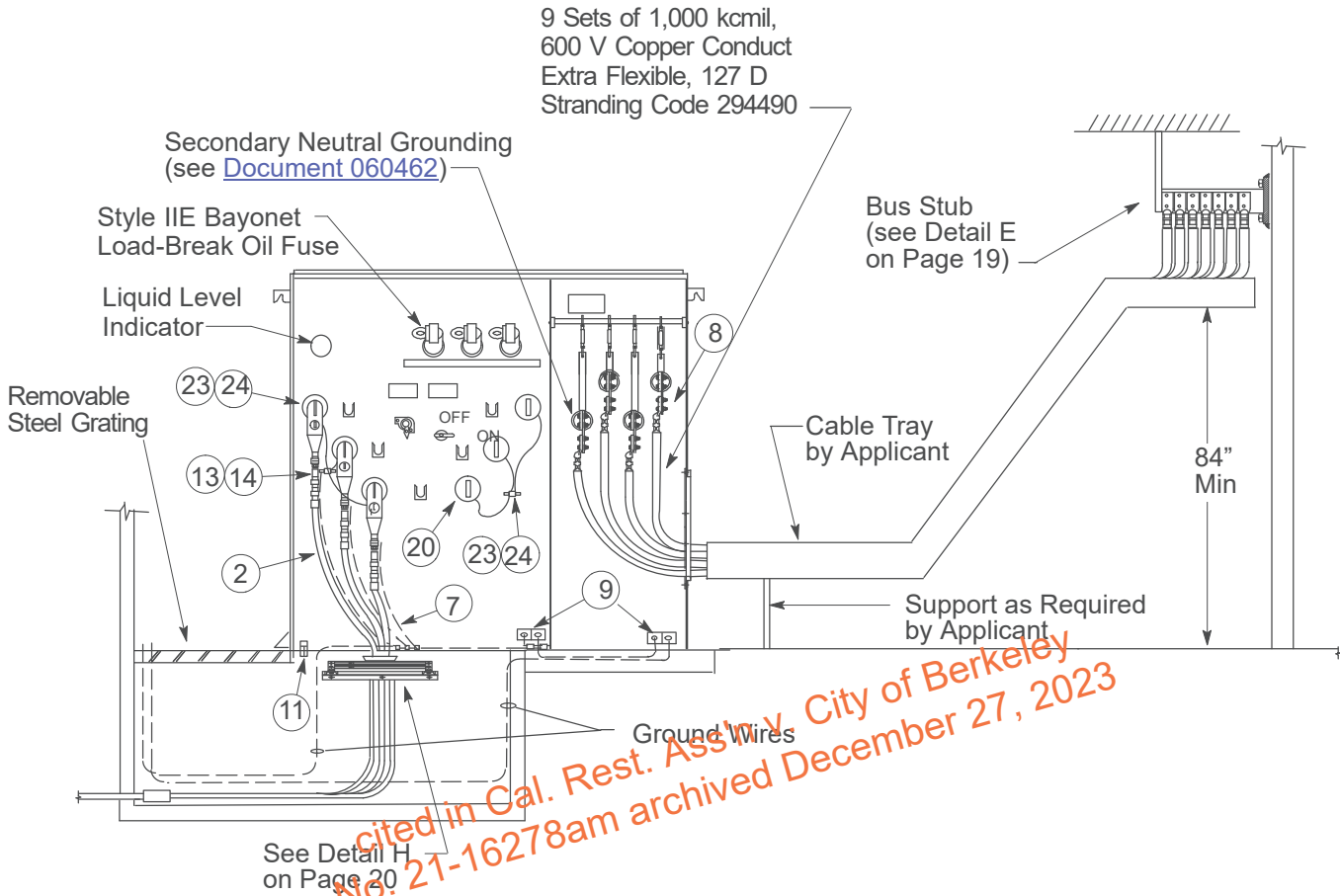
**Note**

1. Primary may also be routed to back wall of vault. Primary may not be routed from primary section of transformer to the back wall underneath the transformer.



### Pad-Mounted Transformer Installed Indoors

#### Layout for Cable Tray Service with a Separate Fire Pump (continued)

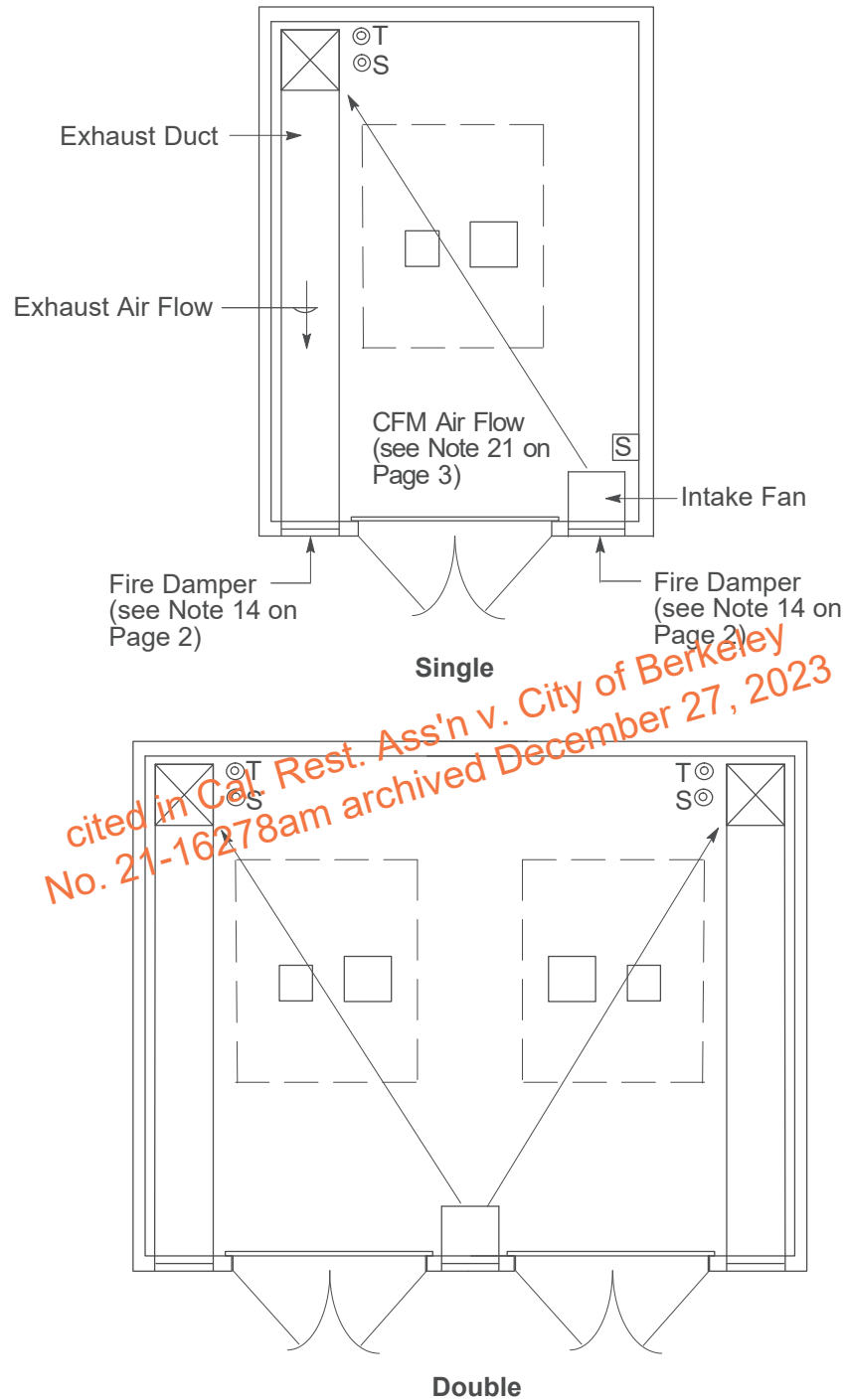


Note: Cable tray shall be vented, with rollers, minimum of 36" wide and 3-1/2" deep.

**Figure 10**  
**3,000 A – 4,000 A Pad-Mounted Service Cable Enclosure**  
**With Fire Pump**

### Pad-Mounted Transformer Installed Indoors

#### Forced Air Details



**Figure 11**  
**Plan View – Single and Multiple Transformer Room Application**

### Pad-Mounted Transformer Installed Indoors

#### Forced Air Details (continued)

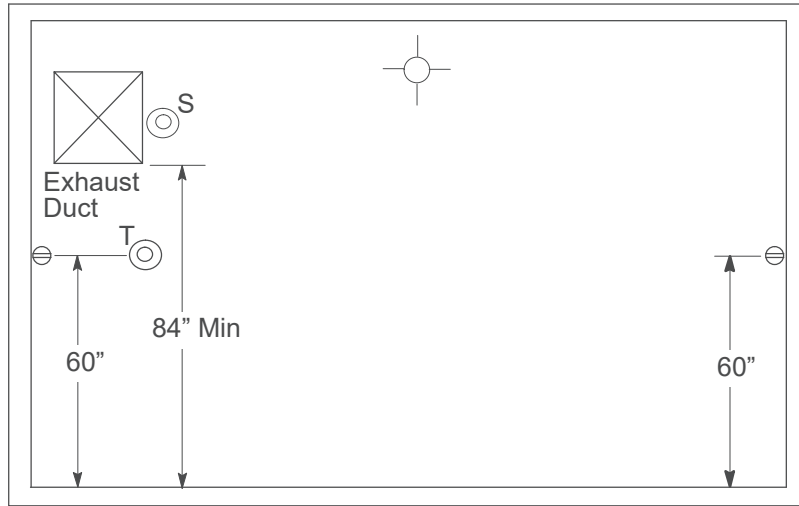


Figure 12  
Section A - A (from Figure 1 on Page 5)

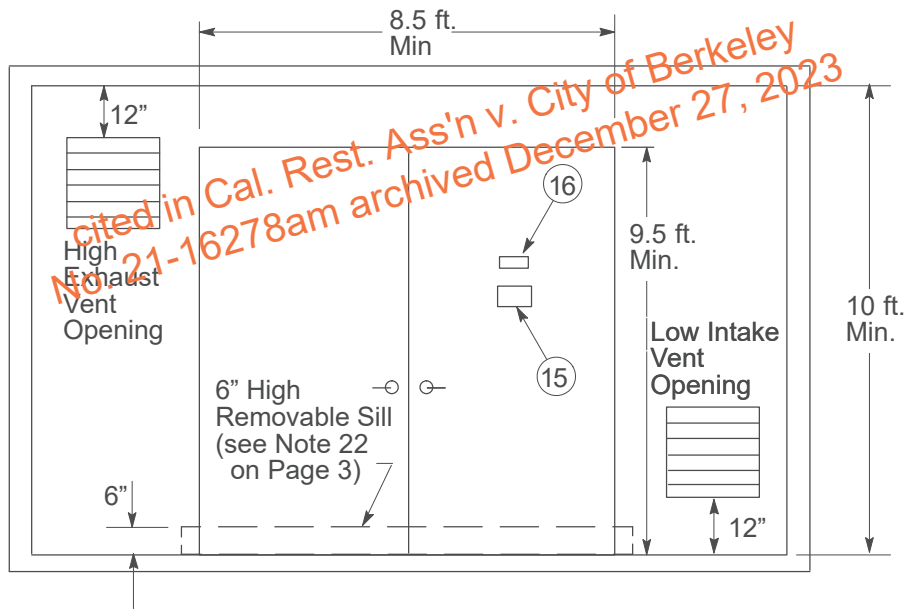
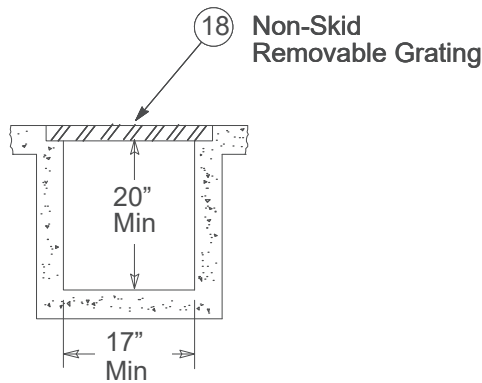


Figure 13  
Front View - Ventilation and Entrance Details

### Pad-Mounted Transformer Installed Indoors

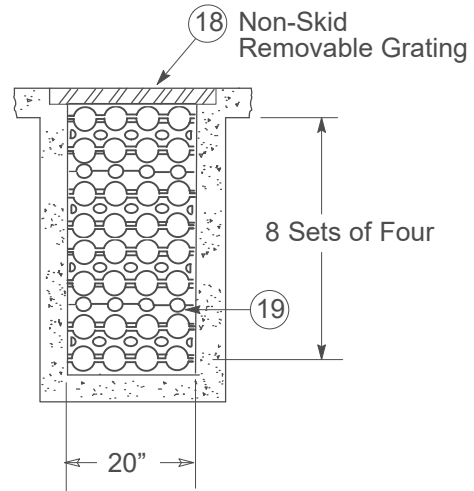
#### Cable Trough Details



Section D-D

Figure 14  
Primary Cable Trough

Note: 3-hour fire rated  
(see Note 14 on Page 2)

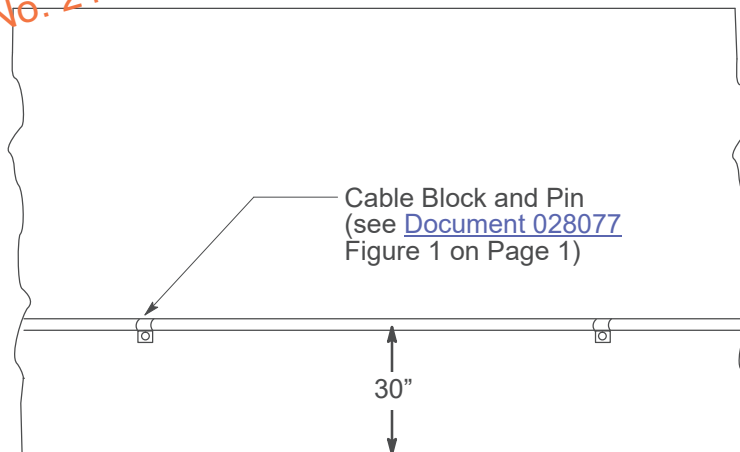


Section E-E

Figure 15  
Secondary Cable Trough for  
400 A - 2,500 A Mains

Note: Size as required to fit duct spacers.  
Dimensions shown are for Formex four  
way space for 2" conduit with 2"  
separation (see Detail C on Page 18).

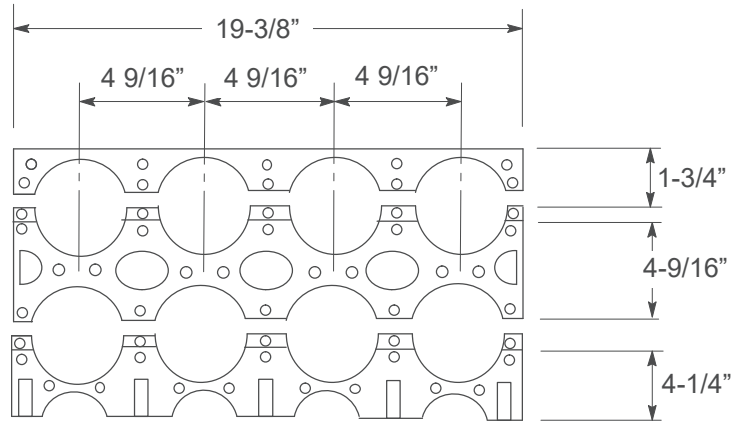
*cited in Cal. Rest. Ass'n v. City of Berkeley  
No. 21-16278am archived December 21, 2023*



Detail B  
Mounting Ground Ring Bus  
to Vault Wall

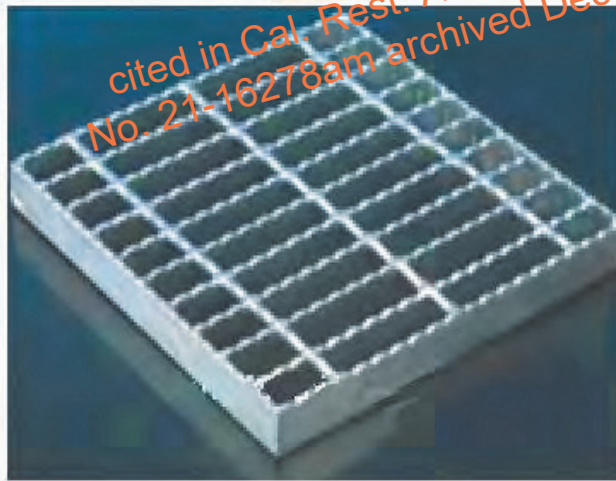
### Pad-Mounted Transformer Installed Indoors

#### Cable Trough Details (continued)



**Detail C**  
**Formex Four-Way Duct Spacer 2" Duct With 2" Separation**

1. Place one duct spacer every 18" from secondary window edge.
2. Functional equivalent may be used.
3. Use one 4-hole spacer with 2" holes for each set of 1000MCM cables, for example:
  - for five sets of cables each spacer set is 4 holes wide by 5 layers deep.
  - for seven sets of cables each spacer set is 4 holes wide by 7 layers deep.



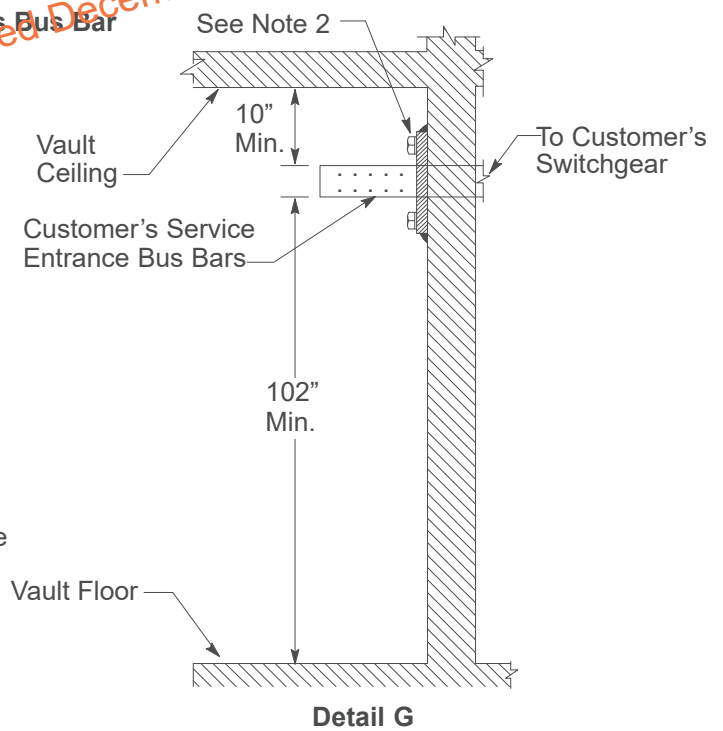
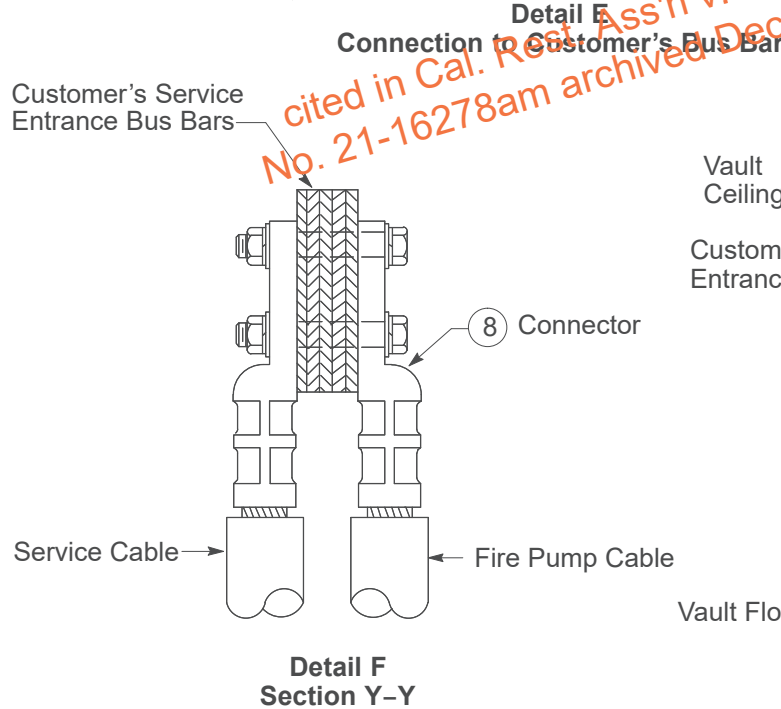
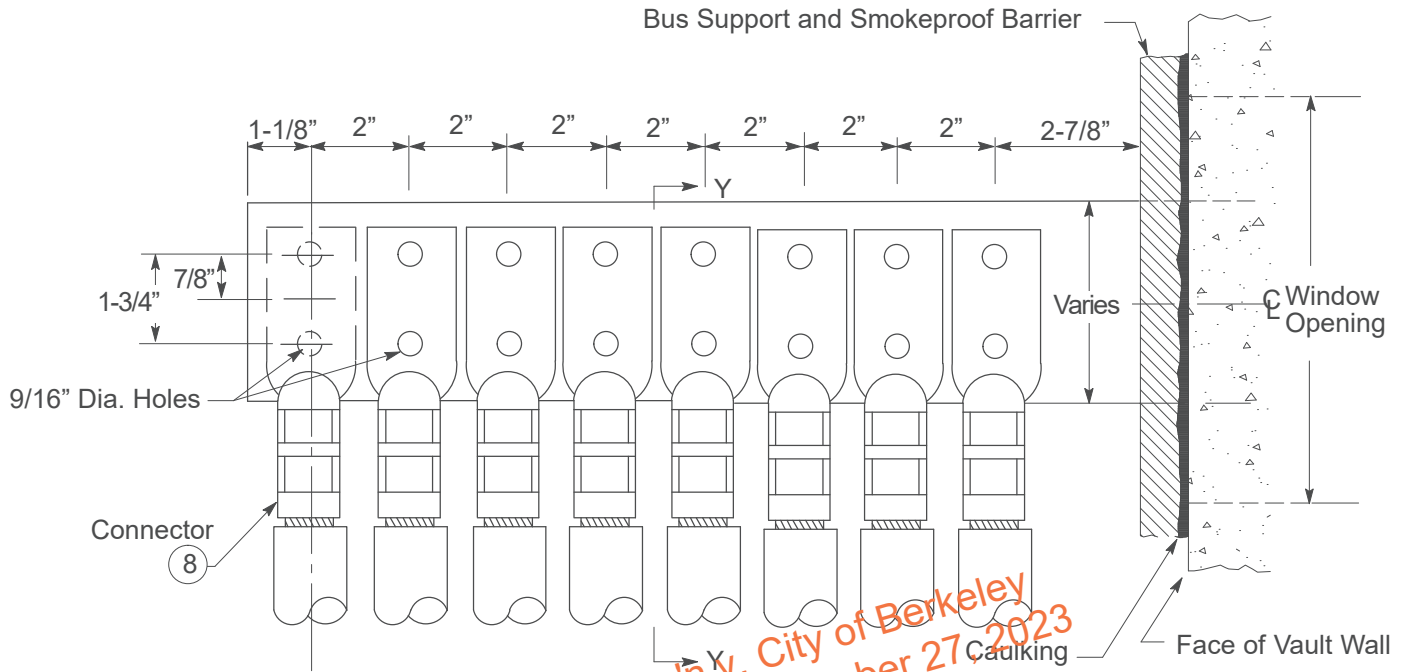
**Detail D**  
**Typical Non-Skid Grating**

1. Size and numbers as required.
2. Maximum weight of each piece shall not exceed 50 lbs.
3. Open area must be at least 45%.

**Pad-Mounted Transformer Installed Indoors**

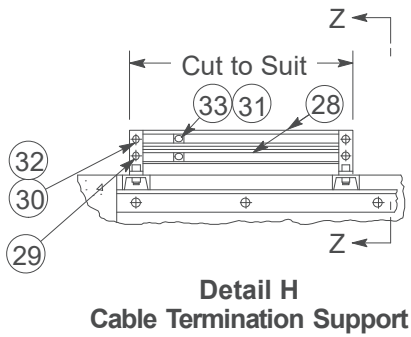
**Bus Bar Termination Details**

1. All exposed grounded metal bolts within 10" of bus bars shall be suitably insulated.
2. Barrier is not needed if firestop supports the bus and is smokeproof.



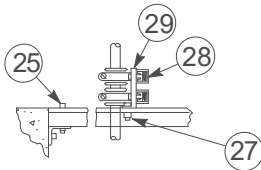
### Pad-Mounted Transformer Installed Indoors

#### Primary Cable Support Details (continued)



**Table 2 Primary Cable Termination Support**

Item	Quantity	Description
25	-	Bolt, Machine 1/2" x 4", Square Head, Galvanized
26	-	Bolt, Machine, 1/2" x 1-1/4" Hexagonal, Head, Galvanized
27	-	Bolt, Machine, 3/8" x 1" Hexagonal, Head, Galvanized
28	2	Channel, 1-1/4", Unistrut A-1000
29	2	90° Angle Fitting, 3/16", Unistrut A-1326
30	4	Spring Nut, 3/8", Unistrut A-1008
31	12	Spring Nut, 1/4", Unistrut A-1006-1420
32	4	Capscrew, Hexagonal Head 3/8" x 1" Galvanized
33	12	Capscrew, Hexagonal Head 1/4" x 1" Galvanized



**Section Z-Z  
Support Mounted Above Floor Surfaces  
(all mounting holes, drill to suit)**



**Alternate Section Z-Z  
Support Mounted Below Floor Surface**

*cited in Cal. Rest. Ass'n v. City of Berkeley  
No. 21-16278am archived December 27, 2023*

#### Revision Notes

Revision 12 has the following changes:

1. Revised language in Note 5 on Page 1.
2. Add Note 19 on Page 2.
3. Revised Figure 11 on Page 15 to single and multiple room applications.
4. Delete Figure 13 on Page 16.

	<b>AGRICULTURAL OVERHEAD SERVICE 300 HP OR LESS</b>	<b>058087</b>
<b>Asset Type:</b> Electric Metering		<b>Function:</b> Design and construction
<b>Issued by:</b> Lisseth Villareal (LDV2)		<b>Date:</b> 12/01/19
<b>Rev. #15:</b> This document replaces PG&E Document 058087, Rev. #14. For a description of the changes, see Page 12.		

**This document is also included in the following manual:**

- [Electric and Gas Service Requirements](#) (Greenbook)
- [Electric Meter Work Practices](#)

**Purpose and Scope**

This document establishes and illustrates the required methods of providing overhead agricultural service of 300 horsepower (hp) or less.

**General Information**

- This document applies to agricultural loads rated 5 through 300 hp, provided both of the following conditions are met.
  - The service is overhead.
  - The load current does not exceed the ampere limitation of the service entrance equipment or PG&E facilities.
- Service Request: The customer should make application for service and verify the available service voltage with PG&E as far in advance of construction as possible. The customer should then notify his pump company of the available PG&E service voltage.
- Available Service Voltage:
  - Non-residential single-phase loads to a maximum of 7-1/2 hp shall be served at 120/240 V, single-phase, 3-wire.
  - Three-phase motors of 5 hp, or bigger up to 30 hp, will normally be served at 120/240 V, three-phase, 4-wire, but may be served at 120/208 V or 277/480 V at the customer's option and if capacity is available from existing facilities.
  - Single or grouped three-phase motors of 30 hp up to 50 hp can be served from an open-delta transformer producing service voltage at 120/240 V, three-phase, 4-wire, if the customer has a combination of single and three-phase loads, otherwise they must be served at 120/208 or 277/480 V, three-phase, 4-wire.
  - Single or grouped three-phase motors from 60 hp through 125 hp shall be served at 120/208 V or 277/480 V, three-phase, 4-wire.
  - Single or grouped motors of 150 hp through 300 hp shall be served at 277/480 V, three-phase, 4-wire.
- General Requirements: PG&E shall furnish and install the overhead service drop, meters and metering current transformers. Unless otherwise stated, all other materials shall be furnished, installed and maintained by the customer and shall comply with the requirements of PG&E. It shall be the responsibility of the customer to ascertain and comply with the requirements of governmental authorities having jurisdiction. In areas where no provision is made for inspection by local authorities, the applicable state regulations shall apply. Local ordinances may include wiring requirements in addition to those shown in this document or in the National Electrical Code (NEC). Consult inspection authorities for requirements, city or county permits, and inspections that may be required before service can be connected.
- Clearances: All overhead conductors may not be in a vertical plane **any** closer than 10 feet from any wellhead. The vertical plane is the plane created between the overhead conductors and the ground. Refer to Figure 1 on Document [025055](#).



**Agricultural Overhead Service 300 HP or Less**

6. Service Pole: When a service pole is required, it shall have a minimum length of 25 feet (set 4-1/2 feet in the ground) unless a longer pole is needed for required ground clearance or to accommodate additional PG&E equipment. The pole will be located at least 10 feet from the motor or load and in such a position that the overhead conductors and any required guy will not interfere with work done at the motor or load. A PG&E pole with high-voltage conductors (over 600 V) shall not be used as a service pole. Refer to [Document 025055](#) for further information on the requirements for customer-owned poles.
7. Service Entrance Conductor:
- The conductors shall be sized and installed in accordance with the applicable requirements of the NEC.
  - A minimum of 18 inches of conductor shall be provided outside of the service head to make connection with PG&E's service drop.
  - When the meter enclosures shown in Figure 9 through Figure 11 on Page 10 are used, the customer shall furnish and connect all line and load-side service entrance conductors.
  - When metering equipment requiring a current transformer (Figure 12 on Page 11 through Figure 15 on Page 11) is used, the customer shall furnish lugs and connect conductors to the line and load sides of the current-transformer mounting base. The unmetered conductor may be cable, but shall be continuous and unspliced in the current-transformer cabinet and shall be located so as to not interfere with the current-transformer installation.
8. Service Entrance Conductor Covering for Service Poles:
- All wires between the service head and the meter shall be enclosed in any of the following:
    - galvanized rigid steel conduit
    - rigid aluminum conduit
    - electrical metallic tubing
    - intermediate metallic conduit
    - PVC plastic conduit having a minimum wall thickness of 0.45 inches (Schedule 40 for 2" PVC conduit or larger, Schedule 80 for 1-1/2" PVC conduit or smaller)
 All fittings shall be raintight.
  - If PVC plastic conduit is used, it need not be covered. If rigid steel or other approved metallic conduit is used, it shall be enclosed with either 1/4-inch thick fiber conduit, 1-1/2-inch thick wood covering or PVC "U" shaped moulding for a minimum distance of 8 feet below the lowest open service entrance conductor. The covering shall be strapped to the pole at intervals not greater than 3 feet (see Pages 7 and 8).
9. Grounding: The customer shall be responsible for bonding and grounding all exposed, non-current-carrying metal parts. Bonding and grounding shall be in accordance with the NEC and local ordinances. PG&E prefers, but does not require, the grounding electrode conductor wire to be protected against physical damage by rigid steel conduit or armored cladding.
10. Metering Requirements:
- The arrangement of service equipment shall place the meter and current-transformer cabinet (if required) on the source side of the customer's service switch or breaker.
  - 125 hp or less: The customer shall provide and install a self-contained, meter socket enclosure, approved by PG&E, for the available service voltage, in accordance with Table 1 on Page 5 and Figure 9 through Figure 11 on Page 10.
  - 130 hp through 300 hp: The customer shall provide and install a PG&E-approved combination meter and current-transformer cabinet in accordance with Table 1 on Page 5 and as shown in Figure 12 and Figure 13 on Page 11, or, as an option, the current-transformer cabinet and separate transformer-rated meter safety-socket box as shown in Figure 14 and Figure 15 on Page 11.
  - Non-residential (agricultural) customer-owned poles are limited to only one meter panel rated less than or equal to 200 amps. Two or more meter panels or a meter panel rated greater than 200 amps must be installed on a panel board construction as shown in [Document 065374](#).

**Agricultural Overhead Service 300 HP or Less**

11. Customer's Control Equipment:

- A. Customer's switch and motor control equipment shall be of proper horsepower and voltage rating and, when exposed to weather, shall be weatherproof.
- B. The customer's control equipment shall be selected in accordance with the requirements of NEC Article 430 and local ordinances. Consideration should also be given to installing open-phase and reverse-phase protection.
- C. Customer's switch and motor control cover shall be effectively locked or sealed if the enclosure contains accessible electrically energized parts.
- D. When a service pole without an adjacent panel board is used, the customer's switch and motor control equipment may be installed as shown on Pages 7 and 8. One side of the pole must be kept clear for climbing.

12. Services to Three-Phase Pumps:

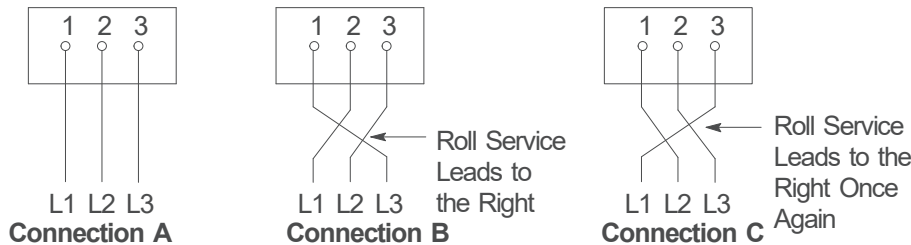
- A. When three-phase service is established to a pump, PG&E's crew will assist in checking for satisfactory pump motor performance if the customer or his representative is present. The construction crew should take "Clamp-on" ammeter readings at the service head, or the customer or his representative can take them at the motor control box. If the reading on the "high" phase is more than 10% higher the reading on the "low" phase, then the phases should be rolled to get the readings as close as possible (see Figure 1 below). The set of readings that gives the lowest difference is the connection that should be retained. It is possible that none of the other readings will be any better. Use the "[Motor Data Sheet](#)", to record all readings.
  - (1) Starting and stopping of the pump should be done only by the customer or his representative. Connections can be changed at the transformer pole or service pole by PG&E's crew or at the motor control box by the customer or his representative.
  - (2) On 240 V, 3-wire services where one phase conductor is grounded, all rolling of leads must be done on the customer's motor leads (at the motor control box), not on PG&E's service leads.
  - (3) Example

Once water was flowing satisfactorily from the pump, the following ammeter readings were taken:

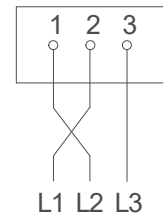
cited in Cal. Rest. Ass'n v. City of Berkeley  
No. 21-16278am archived December 27, 2023

Connection	Amperes		
	<u>L1</u>	<u>L2</u>	<u>L3</u>
A = Original Readings	60	61	67
B = Second Set of Readings	60	62	63
C = Third Set of Readings	59	62	66

Conclusion: Connection B should be used.



**Figure 1**  
Rolling Leads  
(maintains same rotation)



**Figure 2**  
Interchanging Leads  
Reverses Rotation  
(for information only)

- 13. Voltage stabilizer will be furnished and installed by PG&E. Voltage stabilizer is required on 480V, 3-phase, 3-wire ungrounded installations. Refer to [Document 052497](#).

OH: Services  
Greenbook  
EMWP

**Agricultural Overhead Service 300 HP or Less**

References	Location	Document
<u>Dead-End Attachments for Service and Streetlight</u>		
<u>Drop Cables</u> .....	<u>ELS</u> .....	<u>015009</u>
<u>Spool and Clevis-Type Insulators–Distribution Lines</u> ..	<u>OH: Conductors</u> .....	<u>022439</u>
<u>Requirements for Customer-Owned Poles</u> .....	<u>OH: Services/Greenbook</u> .....	<u>025055</u>
<u>Dead-End and Angle Attachments for Aluminum</u>		
<u>Conductors - Distribution Lines</u> .....	<u>OH: Conductors</u> .....	<u>028851</u>
<u>Voltage Stabilizer for 480 Volt, Three-Phase, 3-Wire</u>		
<u>Ungrounded Service</u> .....	<u>OH: Meters/EMWP</u> .....	<u>052497</u>
<u>Agricultural Underground Service 500 HP or Less</u> .....	<u>UG-1: Services/Greenbook</u> .....	<u>054619</u>
<u>Cable and Accessories for Secondary Aerial Cable</u>		
<u>Construction</u> .....	<u>OH: Framing</u> .....	<u>057876</u>
<u>Miscellaneous Hardware for Overhead Line</u>		
<u>Construction</u> .....	<u>OH: Framing</u> .....	<u>058778</u>
<u>Conductors for Overhead Lines</u> .....	<u>OH: Conductors</u> .....	<u>059626</u>
<u>Underground Conduits</u> .....	<u>UG-1: Conduits</u> .....	<u>062288</u>
<u>Overhead and Underground Panel Board</u>		
<u>Construction</u> .....	<u>OH-Services/UG-1: Services</u> .....	<u>065374</u>
<u>Fired Wedge Connectors for Primary and Secondary</u>		
<u>Distribution Lines</u> .....	<u>OH: Conductors</u> .....	<u>066194</u>

*cited in Cal. Rest. Ass'n v. City of Berkeley  
No. 21-16278am archived December 27, 2023*

## Agricultural Overhead Service 300 HP or Less

Table 1 Customer's Metering Equipment Requirements <sup>1</sup>

Service Voltage <sup>2</sup>	Maximum hp <sup>3</sup> Single or Grouped Motors	Metering Equipment's Minimum Current Rating (Continuous/Max. Amps Shown) <sup>8</sup>	Type Meter Equipment Required	Refer to
120/240 V Single-Phase, Non-Residential, 3-Wire	7-1/2 hp Single Phase	100	Self-Contained 4-Jaw Bussed Safety-Socket Meter Box	Figure 9 Page 10
240 V Delta Three-Phase, 3-Wire <sup>4</sup>	30 hp Single or Grouped	100	Self-Contained 5-Jaw Bussed Safety-Socket Meter Box	Figure 10 Page 10
	60 hp Single or Grouped	200		
240/120 V Delta Three-Phase, 4-Wire <sup>5</sup>	30 hp Single or Grouped	100	Self-Contained 7-Jaw Bussed Safety-Socket Meter Box	Figure 11 Page 10
	50 hp Single or Grouped	200		
480 V Delta Three-Phase, 3-Wire <sup>6</sup>	60 hp Single or Grouped	100	Self-Contained 5-Jaw Bussed Safety-Socket Meter Box	Figure 10 Page 10
	125 hp Single or Grouped	200		
	300 hp Single or Grouped	400 <sup>7</sup>	Combination Meter, Current-Transformer and Service Termination Cabinet With 8-Jaw Socket and CT Mounting Base	Figure 12 Page 11
			Separate Current-Transformer Cabinet and Transformer-Rated Meter Box	Figure 14 and Figure 15 Page 11
277/480 V Wye Three-Phase, 4-Wire	60 hp Single or Grouped	100	Self-Contained 7-Jaw Bussed Safety-Socket Meter Box	Figure 11 Page 10
	125 hp Single or Grouped	200		
	300 hp Single or Grouped	400 <sup>7</sup>	Combination Meter, Current-Transformer and Service Termination Cabinet With 13-Jaw Socket and CT Mounting Base	Figure 13 Page 11
			Separate Current-Transformer Cabinet and Transformer-Rated Meter Box	Figure 14 and Figure 15 Page 11

<sup>1</sup> For meter equipment illustration, see Pages 10 through 11.

<sup>2</sup> See Note 3 on Page 1 for available service voltages.

<sup>3</sup> Maximum horsepower for single and grouped motors is based on nameplate rating. Ratings shown are the recommended values for motors running at full load.

<sup>4</sup> Limited availability, consult PG&E.

<sup>5</sup> See Note 3.C on Page 1.

<sup>6</sup> 480 V Delta is not available for new services.

<sup>7</sup> Customer metering equipment rated higher than 400 amps, three-phase, must be pad-mounted and supplied by an underground service.

<sup>8</sup> The metering equipment ratings shown must not be exceeded with motors running at full load. Customer may choose metering equipment with a greater ampacity rating.

**Agricultural Overhead Service 300 HP or Less****Pole Construction**

**Notes:** (For additional information on the requirements for customer-owned poles refer to [Document 025055](#))

1. Omit wood block (see Table 3, Item 1 on Page 7) and conduit covering (see Table 3, Item 5 on Page 7) when PVC service conduit is used. Exception: Wood block is required when service weatherhead is metallic and the neutral service entrance conductor is uninsulated.
2. When the service conduit (see Table 3, Item 6 on Page 7), is metallic or minimum 2-1/2 inch diameter PVC Schedule 80, the enclosure height may be reduced as permitted by [G.O. 95](#) to allow 48 inches minimum meter height from a level standing surface to the center line of the meter.
3. The customer shall extend the service weatherhead to within 18 inches of the pole top unless otherwise instructed by PG&E (see Note 7A on Page 2).
4. For notes and details pertaining to metering equipment, see Note 10 on Page 2.
5. For notes and details pertaining to customer's service disconnect and motor control equipment, see Note 11 on Page 3.
6. Customer's conductors installed in conduit must be in rigid steel conduit, or 2-1/2 inch minimum diameter Schedule 80 PVC plastic on surface of pole.
7. Alternate location for the ground rod to reduce exposure to agricultural equipment is shown in Figure 3 on Page 7.

**Table 2 Customer's Service Attachment Location <sup>1,2</sup>**

Metering Equipment's Current Rating (Continuous/ Max. Amps Shown) <sup>4</sup>	Weatherhead Distance From Top of Pole (inches)		PG&E Service Attachment Type
	Minimum	Maximum	
< = 200	16	18	Weatherhead
400 (1 Ø) <sup>3</sup>	32	34	3 Spool Rack <sup>5</sup>
400 (3 Ø) <sup>3</sup>	40	42	4 Spool Rack <sup>5</sup>

<sup>1</sup> All open wire services require vertical rack construction. See Figure 8, Page 8.

<sup>2</sup> A longer pole may be necessary to obtain the required service clearances from the ground. See Document [025055](#) Requirements for customer-owned poles.

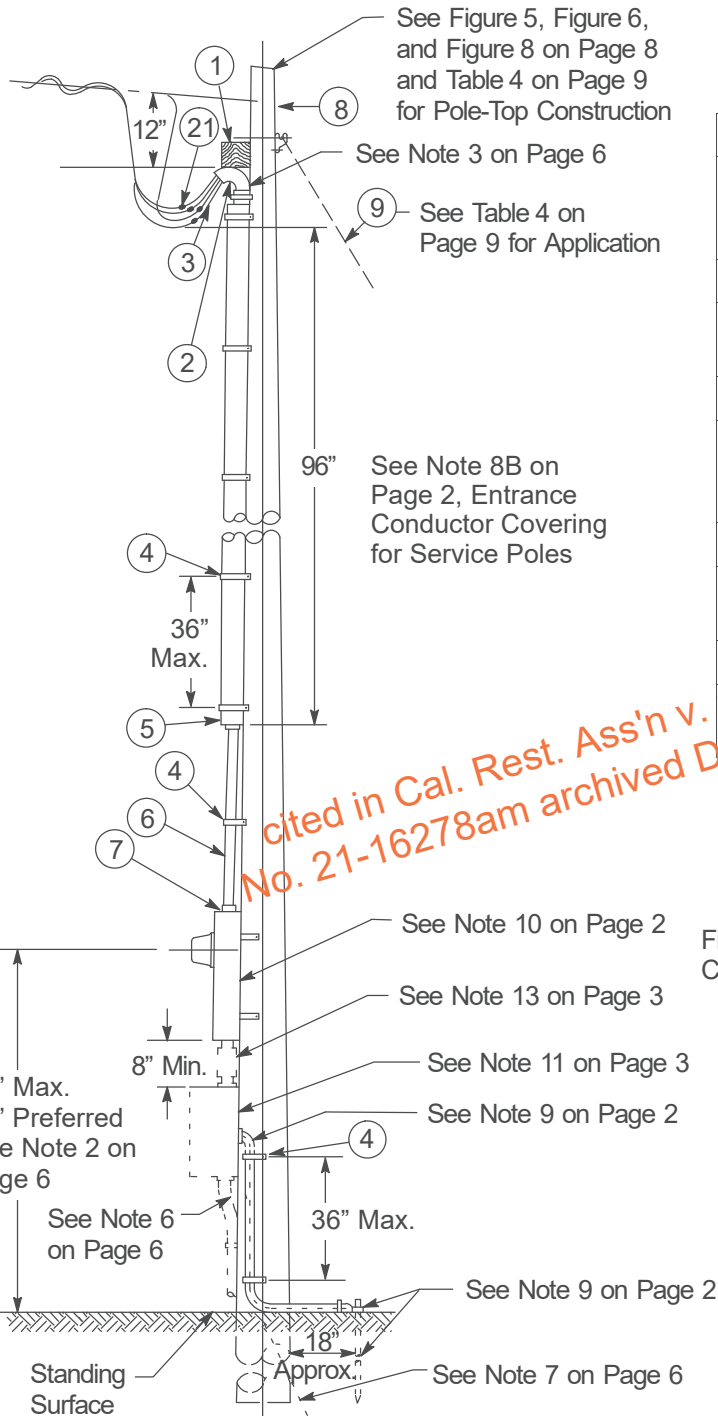
<sup>3</sup> See note 10.D on page 2.

<sup>4</sup> The metering equipment ratings shown must not be exceeded with motors running at full load. Customer may choose metering equipment with a greater ampacity rating for their metering equipment.

<sup>5</sup> The installation of extended rack brackets is no longer allowed. Use Vertical rack construction. See Figure 8 on Page 8.

**Agricultural Overhead Service 300 HP or Less**

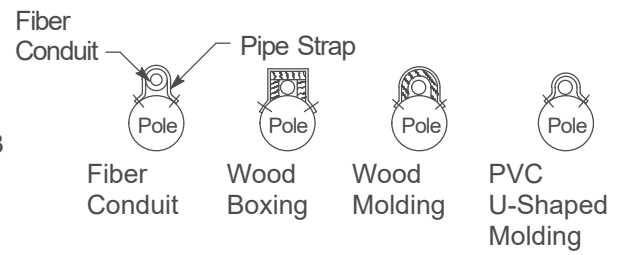
**Pole Construction (continued)**



**Figure 3**  
**Pole Construction for Agricultural Overhead Service 300 hp or Less**

**Table 3 Material to be Furnished and Installed by Customer**

Item	Description
1	Wood Block 4" x 4" x 6" Long Securely Nailed to Pole (may be two 2" x 4" x 6" wood blocks nailed together) (see Note 1 on Page 6)
2	Conduit Entrance Cap or Service Weatherhead
3	Service Entrance Conductors (see Note 7A on Page 2)
4	Pipe Strap, Heavy Duty, Galvanized
5	Covering, Wood, Fiber Conduit or PVC "U"-Shaped Moulding (see Note 8B on Page 2 and Note 1 on Page 6)
6	Service Conduit (see Note 7 on Page 2)
7	Meter Socket or Current-Transformer Enclosure (see Pages 10 through 11)
8	Wood Pole, as Required (25 ft. minimum)
9	Guy Material, as Required. (See footnotes for table 4 on Page 9)



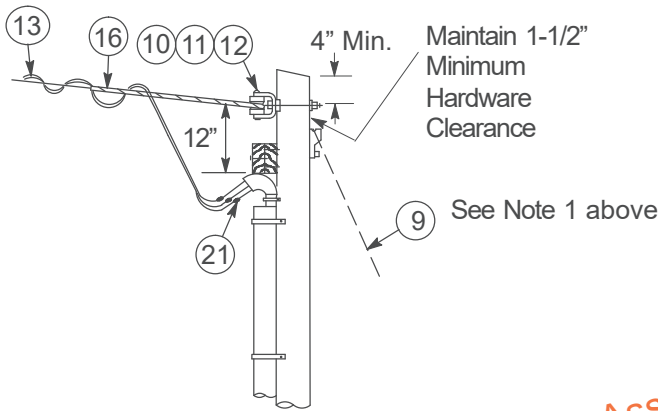
**Figure 4**  
**Methods Of Covering Metallic Conduits (see Note 8B on Page 2)**

### Agricultural Overhead Service 300 HP or Less

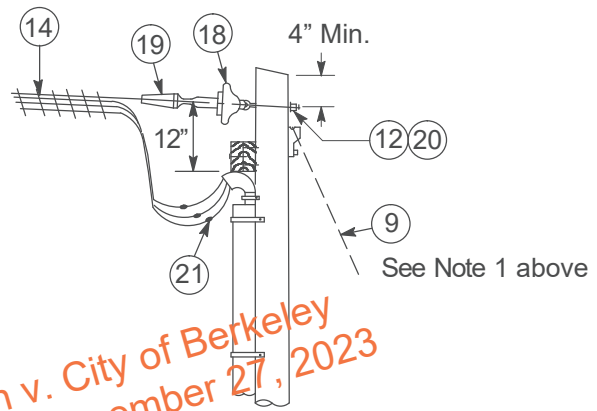
## Pole-Top Construction

### Notes

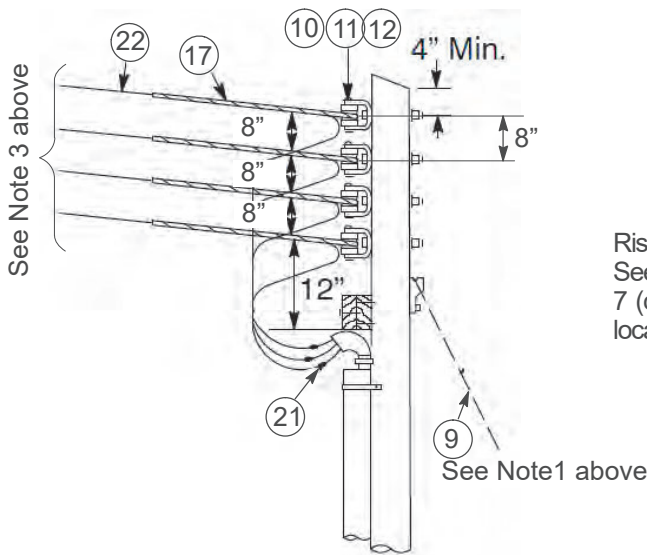
1. See Table 4 on Page 9 for down guy requirements.
2. When a neutral conductor is required inside the molding, replace the bare neutral with the required length of insulated conductor.
3. For customer-owned poles, span lengths are limited to 150'. The vertical separation between conductors in vertical rack construction is 8" minimum.
4. Figure 6, Page 8 installation is not allowed for new construction.



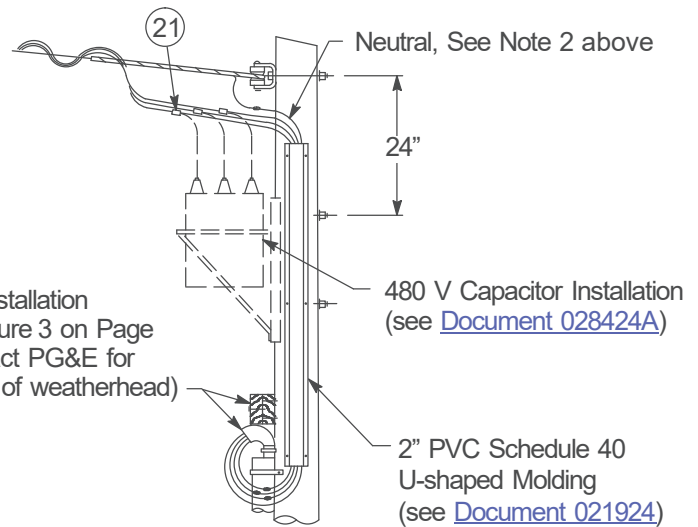
**Figure 5**  
Service Drop Cable Installation



**Figure 6**  
Aerial Cable Installation  
See Note 4 above



**Figure 8**  
Open Wire Cable Installation



**Figure 7**  
Pole-Top Construction for Installation of 480 V  
Capacitor Bank or Other PG&E Equipment

*cited in Cal. Rest. Ass'n v. City of Berkeley  
No. 21-16278am archived December 27, 2023*

**Agricultural Overhead Service 300 HP or Less****Pole-Top Construction (continued)****Table 4 Conductor Application for Customer-Owned Service Poles**

Cable Data <sup>1</sup>			Construction	
Metering Equipment's Current Rating (Continuous/Max. Amps shown)	Span <sup>4</sup> (feet)	Slack Span <sup>3</sup>	Down Guy Requirement	Pole-Top Construction
< = 200	10-150	1/0 Service Drop	2	Figure 5 Page 8
	10-80	4/0 Service Drop	2	Figure 5 Page 8
Above 200 to 400	10-80	4/0 Service Drop	2	Figure 5 Page 8
	10-80	397.5 WP Al Open Wire	2	Figure 8 Page 8

<sup>1</sup> Larger cable may be required if voltage drop requirements are not met.

<sup>2</sup> A down guy is required if construction crosses the street or thoroughfare, or if the pole is not in reasonably firm soil.

<sup>3</sup> Full Tension Span are allowed for existing installations and like for like replacements, but not new construction.

<sup>4</sup> Span length limitations are based on light loading districts. See Document [059690](#) for service drop limitations in other loading districts.

**Table 5 Material to be Furnished and Installed by PG&E**

Item	Description	Document
10	Insulator, Spool and Clevis-Type	<a href="#">022439</a>
11	Bolt, Machine, 5/8" x Length (as required)	<a href="#">058778</a>
12	Washer, 2-1/4" Square, 5/8" Bolt Size	
13	Cable, Service Drop, 1/0 or 4/0 (as required)	<a href="#">059626</a>
14	Cable, Aerial, 1/0 or 4/0 (as required)	<a href="#">057876</a>
15	Watt-Hour Meter, Current Transformer, Test Block, Test Switch (see Note 9 on Page 2)	-
16	Preformed Grip, Service Cable	<a href="#">028851</a>
17	Preformed Grip, WP Aluminum	<a href="#">028851</a>
18	Insulator, Suspension, Clevis-Type	<a href="#">057876</a>
19	Dead End, Automatic, Clevis-Type	
20	Eyebolt, 5/8" Diameter x Length (as required)	<a href="#">058778</a>
21	Connector, Fired Wedge (size as required)	<a href="#">066194</a>
22	Cable, 397.5 kcmil WP Aluminum (as required)	<a href="#">059626</a>



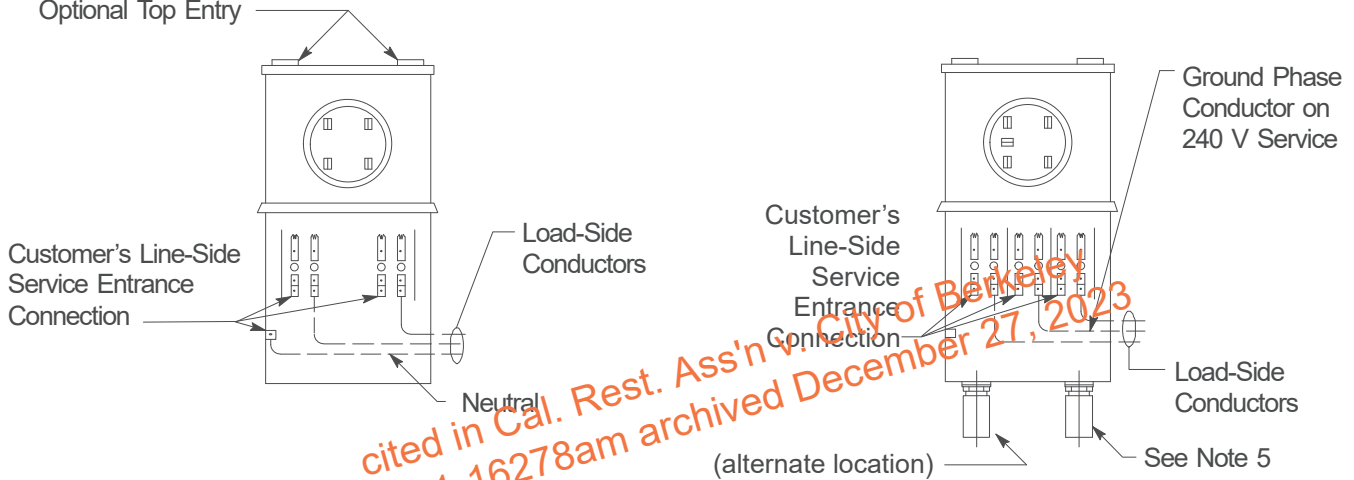
### Agricultural Overhead Service 300 HP or Less

## Safety-Socket Meter Box

### Notes

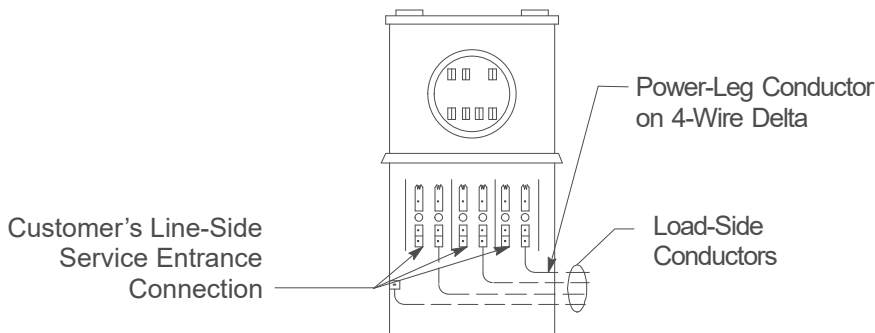
1. Refer to PG&E's [Electric and Gas Service Requirements](#) book for dimension and specification details.
2. Figure 10 and 11 are applicable to maximum of 125 hp pump (self-contained) at 480 V or 277/480 V.
3. 240 V, three-phase, 3-wire service is limited and available only when PG&E's transformers are of the overhead type, the load is limited to three-phase motors (small 240 V, single-phase loads may be permissible in some locations), and in the future, other customers are not likely to be served from the transformer bank.
4. Figure 9 below shows a meter socket with test bypass facilities used for non-residential single-phase service, 120/240 V maximum of 7-1/2 hp. All three-phase services require bypass facilities.
5. Voltage stabilizer, required on 480 V, 3-phase, 3-wire ungrounded services, will be furnished and installed by PG&E. Refer to [Document 052497](#).

Optional Top Entry



**Figure 9**  
**120/240-V, Single-Phase, Self-Contained, 4-Jaw**  
**Bused 0-200 Amp Safety-Socket Meter Box**  
 See Note 4 above

**Figure 10**  
**240-V and 480-V, Three-Phase, 3-Wire,**  
**Self-Contained, 5-Jaw Bused 0-200 Amp**  
**Safety-Socket Meter Box**  
 See Note 3 above and Footnote 6 on Page 5



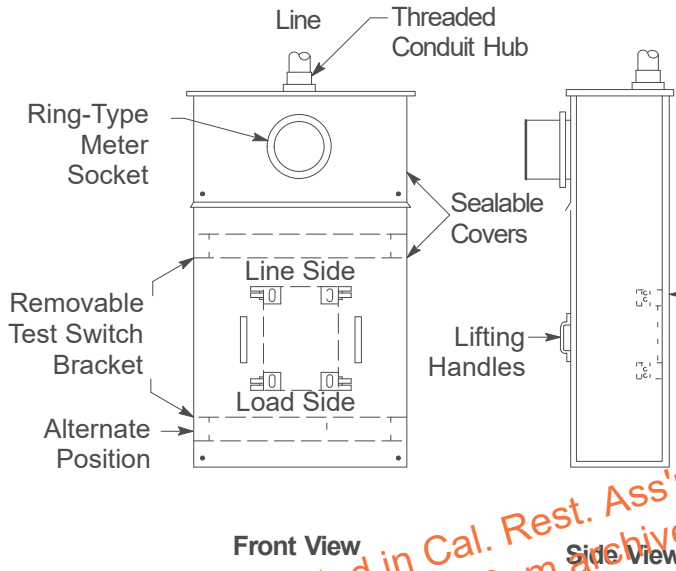
**Figure 11**  
**240/120-V, Three-Phase 4-Wire Delta or 480/277-V, Three-Phase, 4-Wire Wye**  
**Self-Contained 7-Jaw Bused 0-200 Amp Safety-Socket Meter Box**  
 See Note 2 above

**Agricultural Overhead Service 300 HP or Less**

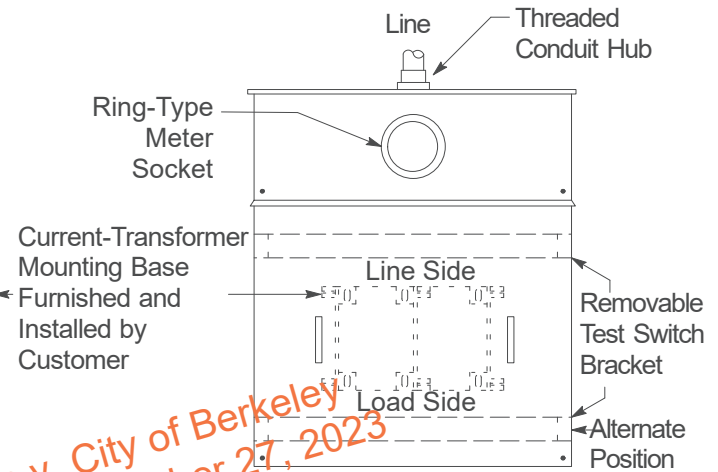
**Transformer-Rated Metering and Enclosure**

**Notes**

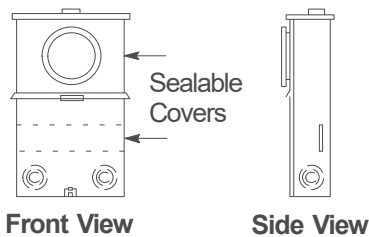
1. Refer to PG&E's [Electric and Gas Service Requirements](#) book for dimension and specification details.
2. Figures 12 through 15 are applicable to a maximum of 300 hp motors.
3. Figures 12 through 15 are applicable to wall-mounted service termination enclosures with maximum ratings of 400 amps, three-phase. Termination equipment that require ratings higher than 400 amps must be pad-mounted and supplied by an underground service.



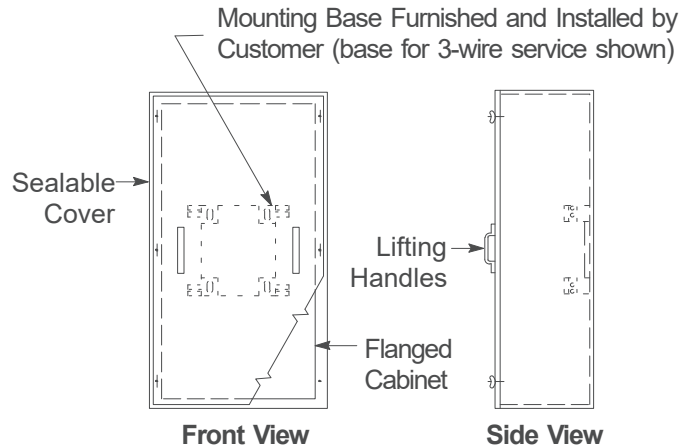
**Figure 12**  
**Combination Meter and Current-Transformer Cabinets**  
**0-400 Amp Rating**  
**For 480 V, 3 $\phi$ , 3-Wire**  
**(See Table 1, Footnote 6 on Page 5)**



**Figure 13**  
**Combination Meter and**  
**Current-Transformer Cabinets**  
**0-400 Amp Rating**  
**For 277/480 V, 3 $\phi$ , 4-Wire Wye**  
**(See Table 1, Footnote 6 on Page 5)**



**Figure 14**  
**Meter Box for Transformer-Rated Metering**



**Figure 15**  
**Current-Transformer Cabinet**  
**0-400 Amp Rating**

**Agricultural Overhead Service 300 HP or Less**

---


**Revision Notes**

Revision 15 has the following changes:

1. Revised Table 1 on Page 5.
2. Revised Table 2 and Footnotes on Page 6.
3. Revised Note 3 on Page 8.
4. Revised Figure 8 on Page 8.
5. Deleted Item #23 in Table 5 on Page 9.

*cited in Cal. Rest. Ass'n v. City of Berkeley  
No. 21-16278am archived December 27, 2023*

Prepared by: SXZO

	<b>DISCONNECT SWITCH REQUIREMENTS FOR DISTRIBUTED GENERATION CUSTOMERS</b>		<b>060559</b>
	<b>Department:</b> Electric Distribution	<i>D. Jantz</i>	<b>Section:</b> Design and Construction
<b>Approved by:</b> Daniel Jantz (DWJ7)		<b>Date:</b> 3/25/2022	
<b>Rev. #07:</b> This document replaces PG&E Document 060559, Rev. #06. For a description of the changes, see Page 7.			

**Note:** This document also is included in PG&E's [Distribution Interconnection Handbook](#).

### Purpose and Scope

This document describes the requirements for low-voltage (0–600 V), isolating, disconnect switches for customer generation and energy storage systems. These requirements apply to customer generation and energy storage systems that are designed to parallel and backfeed (e.g., PV) into the PG&E system or for emergency or backup purposes only. This document also describes PG&E's minimum functional and location requirements for switches. A disconnect switch device provides a visible open clearance point when it is necessary to isolate the customer's generator from the PG&E system.

### General Information

1. Provide a disconnect device to electrically isolate the customer's generator from the PG&E system in order to establish a clearance point for maintenance and repair work in accordance with PG&E safety rules and practices.
2. The disconnect switch device must be installed to only isolate the customer generation sources and must not disconnect customer loads.
3. The disconnect device must be installed between the PG&E meter and all generation sources.
4. The device must be physically located for ease of access and visible to PG&E employees within 10 feet of the meter. The device must be located in close proximity, or within line of sight, of the meter.
5. General or light duty disconnect switches typically are installed when the voltage is 240 V or less and the ampere rating 600 amps or less. Use heavy-duty disconnect switches for all applications above 240 V and 600 amps.
6. The ampacity rating of a disconnect switch must be equal to or greater than the ampere rating of the generator.
7. The neutral conductor shall not be switched.
8. Three-pole switches may be used in single-phase applications.
9. Disconnect switches with an interlock are allowed provided they meet all of the functional requirements. An interlock system allows the switch to be opened (off) by the producer, but cannot be closed (on) until reset by PG&E.
10. All disconnect devices must have locking provisions that accept a PG&E padlock with a 5/16-inch lock shaft. Keyed locks are not allowed. If the disconnect device is operable without opening the enclosure, the operating handle must be lockable. If the enclosure must be opened to operate the disconnect device, the enclosure must be lockable.
11. Molded case circuit breakers, pull-out type disconnects, or any other similar device are not acceptable as an approved disconnect switch.
12. For applications not described, contact the PG&E Electric Generation Interconnection (EGI) department.
13. Interconnections in any PG&E sealable compartment are **NOT** allowed without written authorization from the Electric Meter Engineering or Electric Distribution Standards departments. For any questions, contact PG&E's EGI department.

## Disconnect Switch Requirements for Distributed Generation Customers

---

### Disconnect Switch Requirements

#### Basic

As specified and in *Electric Rule 21*, “Generating Facility Interconnections,” and in PG&E’s [Distribution Interconnection Handbook](#), the generating system or facility must have an ac disconnect switch. The device must meet all of the PG&E requirements, as specified in this document.

All disconnect switches must conform to nationally recognized standards and meet all applicable certification requirements. These include, but are not limited to: NFPA 70–National Electrical Code (NEC), California Electrical Code (CEC), Underwriters Laboratories (UL), or other Nationally Recognized Testing Laboratory (NRTL).

PG&E-approved disconnect switch models, rated up to 1200 amps, currently listed in *both the Eaton and Siemens Safety Switch Cross-Reference Guides*, meet all of the functional requirements described below. These guides can be found on PG&E’s [Distribution Interconnection Handbook](#) website at <http://www.pge.com/dih/>. Disconnect switches rated over 1200 amps and up to 4000 amps must meet all of the requirements described in this document.

#### Functional

- Manually operated: Operated by a person and not operated electronically.
- Gang-operated: One switch handle opens and closes all phases simultaneously.
- Includes marking or signage on the switch that clearly indicates the open (off) and closed (on) positions.
- Lockable in the open (off) position using a PG&E padlock.
- Allows visible verification that an air-gap of separation has occurred between the blades and contact points.
- Has a viewing window, for visible verification, on all pad-mounted (floor standing) disconnect switches. A viewing window is not required, but allowed, on all wall-mounted disconnect switches.
- A fusible ac disconnect switch is required for generators that do not have over-current protection (i.e., breakers, fuses) at the point of interconnection with the utility.
- Adequately sized to handle fault and over-current conditions.

#### Labeling

- Permanently attached signage on the front that explains this is the ac disconnect switch for the generation. Example: “UTILITY AC DISCONNECT SWITCH”.
- Labels shall be permanent and suitable for the environment and shall be engraved phenolic or comply with ANSI Z535.4. Lettering shall be a minimum 3/8” high and in all capitals.
- When the disconnect switch is not grouped with the meter panel provide a map showing the location.
- If a Net Generation Output Meter (NGOM) is installed provide proper labeling as described and a map showing the location if not grouped together with the other meter(s) and disconnect switch.

#### Location

- Easily accessible by PG&E, when requested.
- Located 10 feet or less, in line of sight, from PG&E’s electric meter at the point of common coupling or interconnection and is seen easily from the meter panel.
- Installed in an approved electric meter room 10 feet or less, in line of sight, from the PG&E’s electric meter.
- If installed outdoors with the meter the disconnect switch must be at the same grade level.
- Not allowed on; any floor or level above grade, on a roof, or inside a room or area that is not an approved electric meter room.

## Disconnect Switch Requirements for Distributed Generation Customers

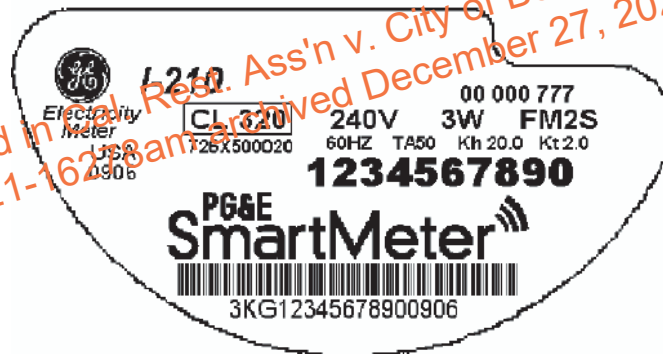
- When wall-mounted or floor standing (pad-mounted), installed at a vertical height of between 48 inches (minimum) and 75 inches (maximum), as measured from the ground to the top of the disconnect switch enclosure.
- Clearly marked on the submitted single-line diagram indicating the manufacturer, model type, voltage rating, current rating, and location.
- If the device is not adjacent to the PG&E's electric revenue meter(s), a clear map and signs indicating of the location of the disconnect switch are required. If the disconnect switch is not accessible outside the locked premises, include signs with contact information and a distribution provider-approved locking device for the premises.
- Installed in a safe and acceptable location that meets the same working space requirements as a meter panel. See Greenbook section 5.4.4 Working Space.

### Exemption to the Disconnect Switch installation Requirement

Applicants with inverter-based generating systems that are supplied by PG&E single phase services up to 240 volts may be exempted from installing a disconnect switch, as determined by PG&E, if the meter panel that is interconnected with the generation source(s) meets **all** of the following conditions:

- Self-contained (not transformer-rated).
- Accepts form "S" socket-based (e.g., FM2S) meters (not bolt-on meters).
- Rated for 320 amps (CL 320) or less of "continuous" current.
- Single-phase, 120/240 volt or 120/208 volt.

Any generation system that does not meet these conditions must install a disconnect switch, as required by PG&E.



Typical Socket-Based Meter Label

## Disconnect Switch Requirements for Distributed Generation Customers

---

### Definitions:

**Backfeed:** The energizing of a utility's distribution system from a non-utility generation source.

**Disconnect Switch:** A disconnect device that the customer is required to install and maintain in accordance with the requirements described in this document. It will completely isolate the customer's generating facility and system from the electric utility's distribution grid. The device includes a visible open, as defined below.

**Distributed Generation:** Any type of customer-owned electric generator, static inverter, or generating facility and system that has the capability of being operated in parallel with an electric utility's distribution system.

**Distribution System:** The infrastructure constructed, maintained, and operated by a utility to deliver electric service to retail customers at primary and secondary distribution voltages.

**Generating Facility:** All or part of the customer's electrical generator(s) or inverter(s) together with all protective, safety, and associated equipment necessary to produce electric power at the customer's facility.

**Onsite Generation System:** A facility or energy system for generating electricity that:

- A. Uses renewable, gas, propane, or other form of energy to generate electricity.
- B. Is isolated from the distribution system at the customer's premise when the utility grid is de-energized.
- C. Operates in parallel or not in parallel with the utility's distribution facilities.
- D. Is intended primarily to offset part or all of the customer's requirements for electricity from the utility.

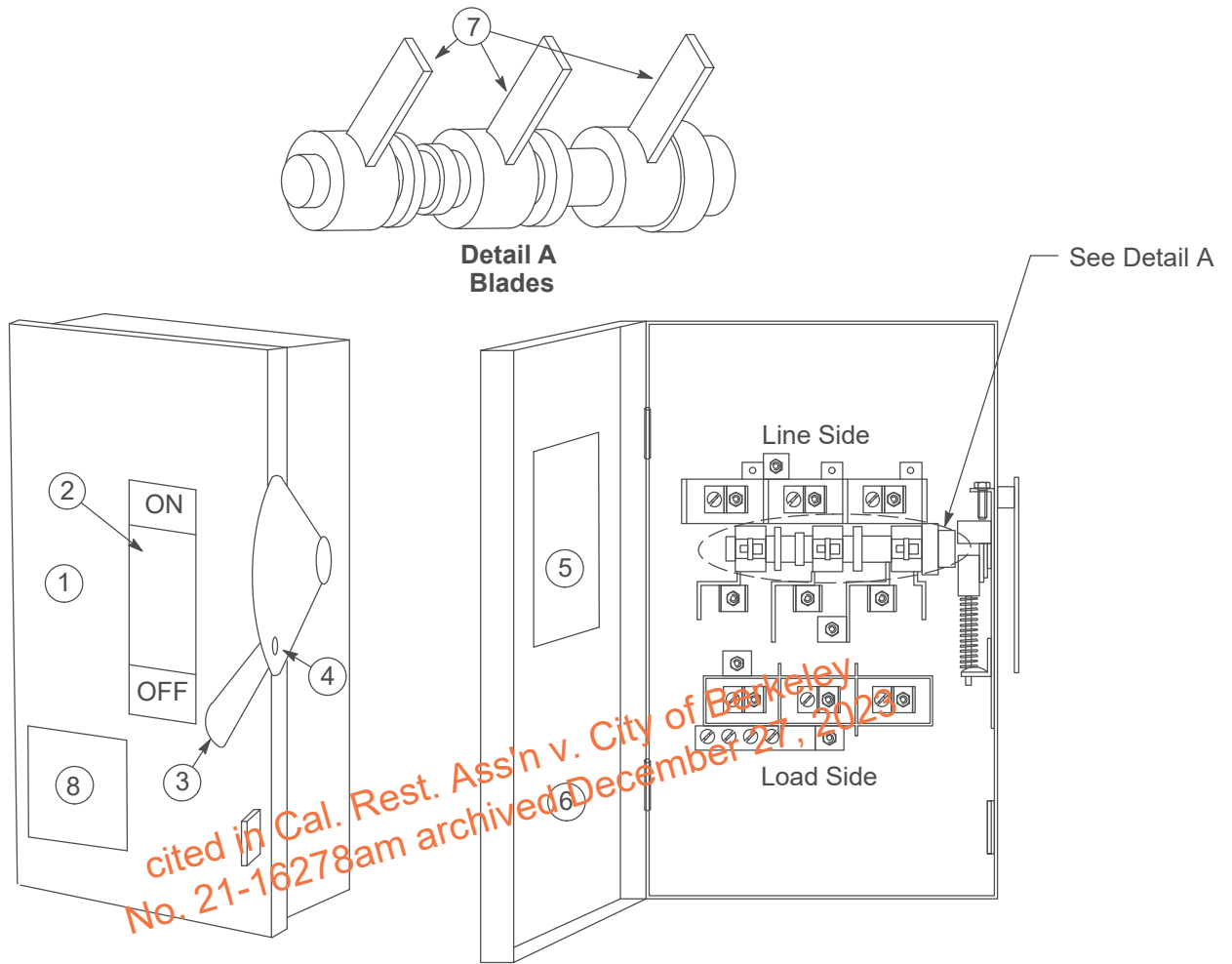
**Open Position:** The disconnect blades are separated from the contacts for each phase, preventing the flow of electricity between them.

**Visible Open:** An air gap must be visible at the trailing edge of the moveable disconnect blades when the switch is in the open position.

cited in Cal. Rest. Ass'n v. City of Berkeley  
No. 21-16278am entered December 27, 2023

## Disconnect Switch Requirements for Distributed Generation Customers

### Customer Installed Disconnect Switches and Wiring Diagrams



**Figure 1**  
**Typical AC Disconnect Switch**

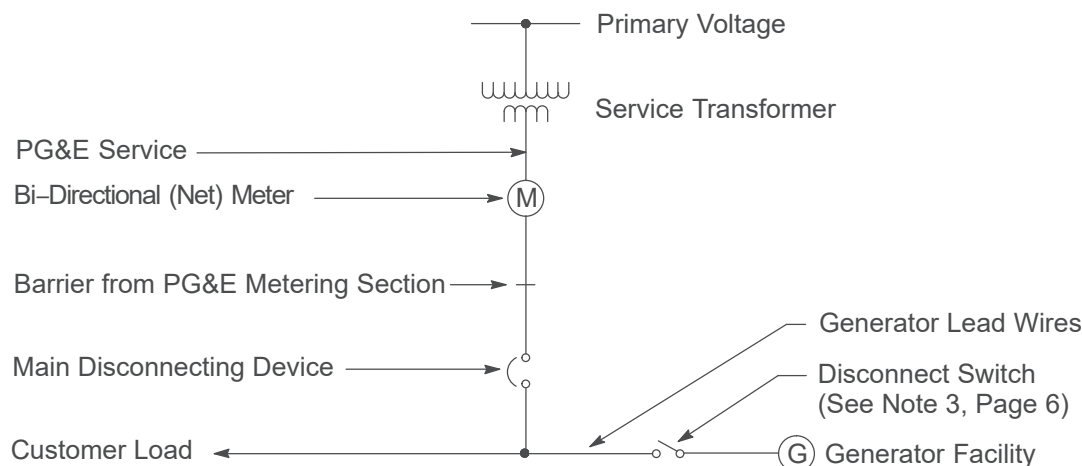
**Table 1 List of Items Required for the AC Disconnect Switch**

Item	Description
1	AC Disconnect Switch Enclosure – General or heavy-duty, indoor or outdoor, fused or unfused, UL/NRTL certified. As required.
2	Visible ON/OFF label.
3	Switch Handle – Manual, single pole for gang operation.
4	Provision For Locking in the Off (Open) Position – Accommodates a PG&E padlock with 5/16-inch lock shaft.
5	Device Label – Includes relevant information (device ratings, UL certification, etc.) about the device.
6	Operable Door – Allows visible verification of blade position.
7	Blades – Solid or Fused. Allows visible verification that separation from contacts has occurred.
8	Ultraviolet (UV) and Weatherproof label stating “Utility Disconnect Switch” – Placed on the outside in the front of the disconnect switch. See Labeling requirements on Page 2.

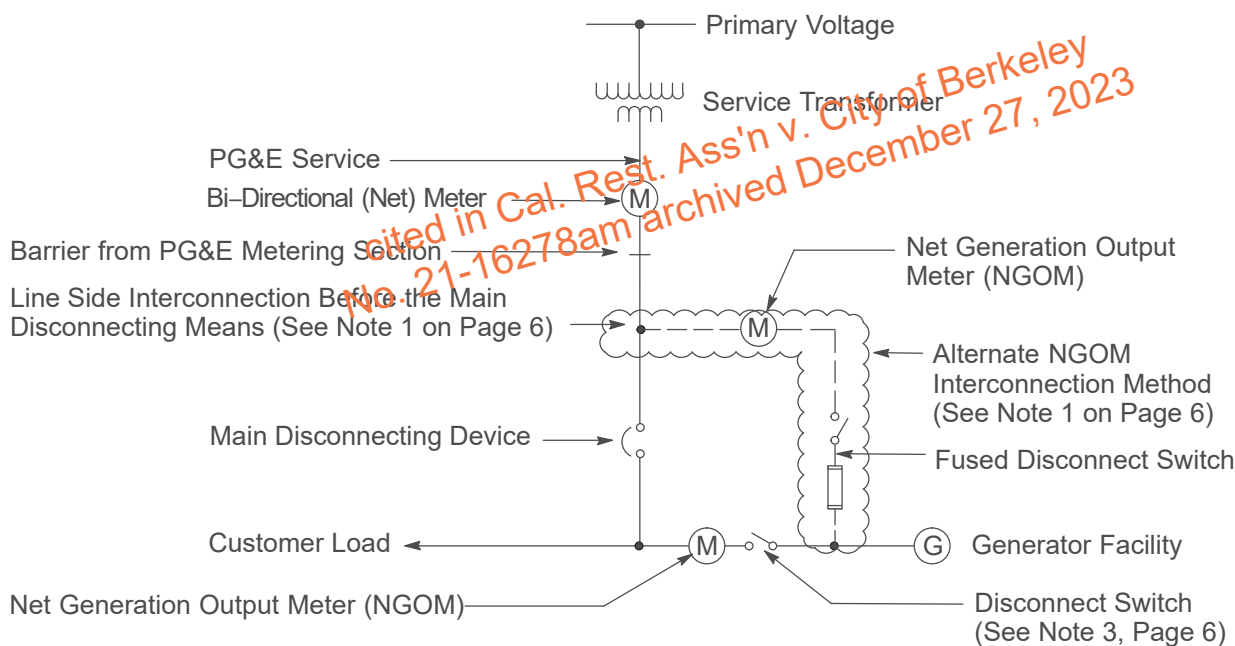


## Disconnect Switch Requirements for Distributed Generation Customers

### Customer Installed Disconnect Switches and Wiring Diagrams



**Figure 2**  
**Typical Disconnect Switch Wiring Diagram**



**Figure 3**  
**NGOM Disconnect Switch Interconnection**

#### Notes for Figure 2 and Figure 3:

1. An interconnection placed before the main disconnecting device requires approval. Submit a variance request to the PG&E's Electric Generation Interconnection (EGI) Department. If a line (Supply) side interconnection is approved, install a fused disconnect switch before the NGOM, as shown in Figure 3. Note, customer cables and equipment are **not** allowed in any PG&E-sealed section.
2. Energy storage systems must have an acceptable disconnecting device that is easily accessible, as determined by PG&E, to prevent backfeed into the NGOM while performing work on the NGOM.
3. The disconnect switch may qualify for the exemption if all the requirements on Page 3 are met.

## Disconnect Switch Requirements for Distributed Generation Customers

---

### Revision Notes



Revision 07 has the following changes:

1. Revised Note 1 on Page 1 (General Information).
2. Revised Note 2 on Page 1 (General Information).
3. Corrected Figure 3 on Page 6.

*cited in Cal. Rest. Ass'n v. City of Berkeley  
No. 21-16278am archived December 27, 2023*

cited in Cal. Rest. Ass'n v. City of Berkeley  
No. 21-16278am archived December 27, 2023

Prepared by: ABB1

	<b>RESIDENTIAL AND SMALL COMMERCIAL OVERHEAD TO UNDERGROUND ELECTRIC SERVICE CONVERSION</b>		<b>061032</b>
	<b>Asset Type:</b> Electric Metering		<b>Function:</b> Construction
<b>Issued by:</b> Quoc Hoang (QXH1)	<b>Date:</b> 04-15-11		
<b>Rev. #04:</b> This document replaces PG&E Document 061032, Rev. #03. For a description of the changes, see Page 4.			

**This document is also included in the following manuals:**

- [Electric and Gas Service Requirements \(Greenbook\)](#)
- [Electric Meter Work Practices](#)

**Purpose and Scope**

This document shows methods acceptable by PG&E, to be used by residential and non-residential (200-amp or less main service switch) customers when converting existing 2-wire or 3-wire overhead services to underground.

**General Information**

1. A typical overhead service conversion is illustrated in Figure 1 on Page 3. PG&E will install cable in a conduit system provided by the applicant. Various surface mount and semi-flush meter socket installations (illustrated in Figure 2 on Page 3 through Figure 7 on Page 4) are used with services converted to underground. The conversion option selected by the customer shall comply with all local building codes and ordinances. The customer shall furnish, install, own, and maintain termination facilities on or within the building to be served.
2. Local ordinances may include requirements in addition to those shown in this document. Consult local inspection authorities for these requirements. In areas where local ordinances require permits and inspection, these must be obtained before PG&E can establish service. PG&E will install meter(s) after an inspection clearance has been given by the appropriate electrical inspection authority.
3. When a service larger than 200 amps is desired, the customer shall consult with the local PG&E representative.
4. Service Conduit and Termination
  - A. PG&E will install the underground service cable and make the connections at the service termination point in accordance with [PG&E's Electric Rule 16](#). The underground service lateral conductors will be installed, owned, and maintained by PG&E from PG&E's distribution system to the termination facility as indicated in Figure 2 through Figure 7 on Pages 3 through 4.
  - B. The customer shall provide trenching, conduit and backfill on his property in accordance with PG&E specifications and pay any costs required by [PG&E's Electric Rule 16](#).
  - C. Service conductors will be installed in conduit as shown in Figure 1 on Page 3. For conduit size, refer to PG&E [Document 063927](#) for residential service or [Document 063928](#) for commercial service.
  - D. The customer shall contact the local PG&E office to discuss service arrangements and agree upon the "Electric Service Location" before trenching or wiring.
  - E. The customer shall provide and install, in addition to termination facilities, all equipment needed to modify the service entrance when changing from overhead to underground service.
  - F. For conduit type on or within the applicant's building, refer to PG&E [Document 063927](#) or [Document 063928](#). Also consult local code authority.
  - G. Install bend in direction of service trench. To facilitate cable installation, only one 90° bend is permitted in the riser. If a deeper trench is required, a minimum radius bend, per PG&E [Document 063927](#) or [Document 063928](#), shall be installed to the same depth as the trench.

### Residential and Small Commercial Overhead to Underground Electric Service Conversion

- H. If the trench is used jointly with other facilities (telephone, cable TV, etc.), increased cable depth may be required. Refer to PG&E's electrical and gas service requirements [Electric and Gas Service Requirements Manual \(Greenbook\)](#) Appendix B, Electric and Gas Service Documents: Joint Trench Configurations and Occupancy Guide.
  - I. Size and type of cable, conduit, and other facilities on the load side of the service termination point are subject to local code requirements.
  - J. To avoid cable insulation damage, the ends of all risers shall be provided with a suitable termination fitting such as bushing, nipple, hub or end bell, etc.
  - K. Pull termination box as specified in Table 1 on below. Item 6 is for service up to 250 kcmil cable. For larger conductor, size box as required. See PG&E [Document 058817](#).
  - L. The point where PG&E's service conductors connect to the customer's conductors, as shown in Figure 2 on Page 3 through Figure 7 on Page 4, is identified as the "PG&E Service Termination Point."
  - M. Item 3 in Figure 4 on Page 4 and Figure 5 on Page 4, may be used only if the service conductor is 1/0 AWG or smaller, and can be pulled from the PG&E end of the service.
  - N. Customer may install short-radius conduit fitting (i.e. service elbows that prevent water from penetrating the fitting at termination to meter panel). Short radius conduit fittings should not contain splices or taps. The cover also must be sealable by PG&E personnel.
5. Grounding: The customer shall be responsible for bonding and grounding all exposed non-current-carrying metal parts. Grounding shall be in accordance with the National Electric Code (NEC) and local ordinances, except that the grounding wire shall be protected against mechanical damage by rigid steel conduit or armored copper ground wire.
6. Metering Requirements: Meter will be furnished and installed by PG&E.

**References**

	Location	Document
<a href="#">Trench and Installation Requirements for URD Cable Terminating Underground Electric Services 0-600 Volt in Customer-Owned Facilities</a>	EES	<a href="#">040686</a>
<a href="#">Methods and Requirement for Installing Residential Underground Electric Services 0-600 V to Customer-Owned Facilities</a>	UG-1: Services/Greenbook	<a href="#">058817</a>
<a href="#">Methods and Requirements for Installing Commercial Underground Electric Services 0-600 Volts to Customer-Owned Facilities</a>	UG-1: Services/Greenbook	<a href="#">063927</a>
<a href="#">Methods and Requirements for Installing Commercial Underground Electric Services 0-600 Volts to Customer-Owned Facilities</a>	UG-1: Services/Greenbook	<a href="#">063928</a>

No. 21-16278am archived December 27, 2023  
Cited in Cal. Rest. Ass'n v. City of Berkeley

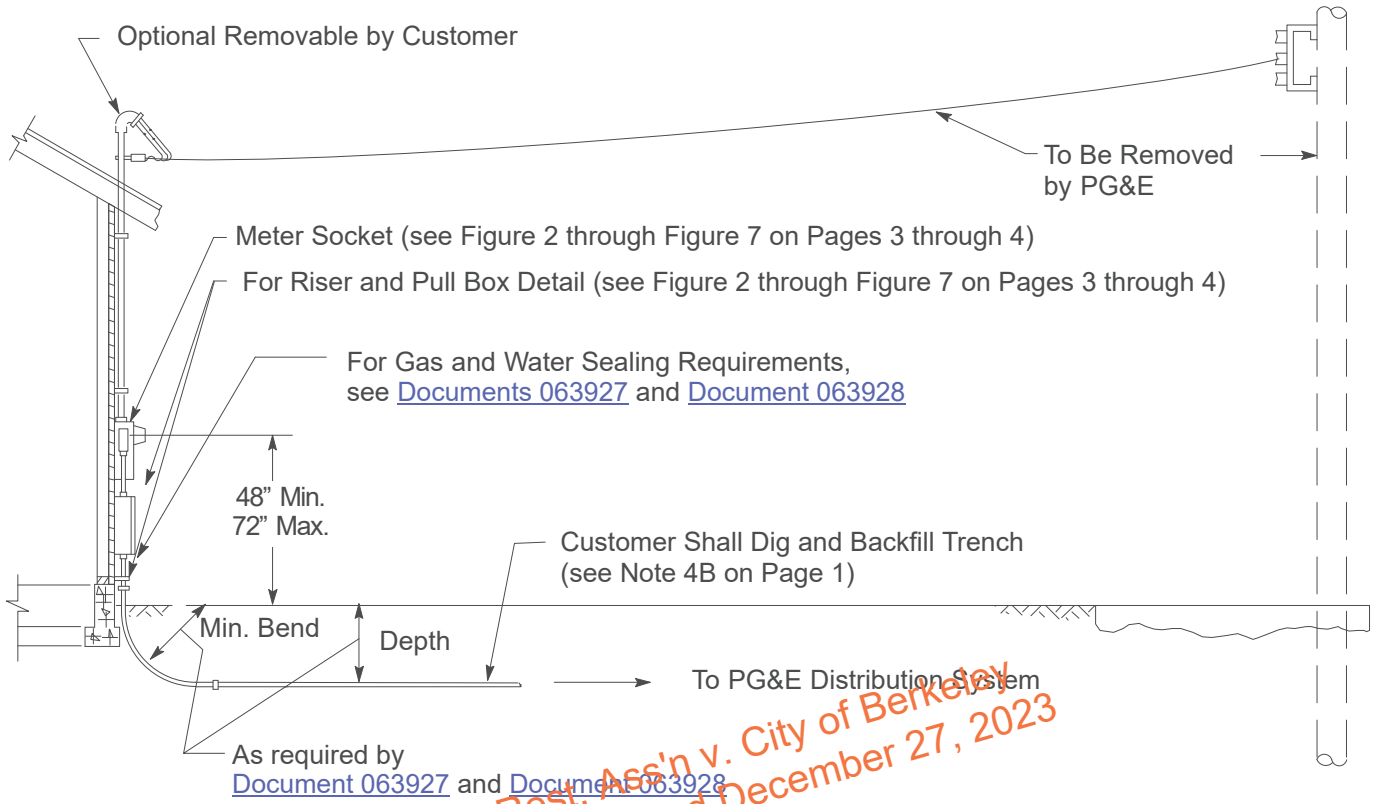
**Table 1 Description of Items to be Furnished and Installed by Customer**

Item	Description
1	Option 1: Meter Adapter, Cooper B-Line Cat. No. MARR20L45GRSD (160A) Use with Customer's Panel Rated at 160A Continuous <sup>1, 2</sup>
	Option 2: Meter Adapter, Ekstrom Industries No. 722B (175A). Specify Left, Right, or Bottom Hub
2	Combination Service Meter and Breaker Panel (rating as required)
3	Pull Termination Box, 8" x 12" x 4", Rain-Tight, Circle A-W (Cooper B-Line) No. R-9007A or Equivalent (see Note 4M on Page 2)
4	Conduit, See Notes 4C and 4G on Page 1
5	Hub to Be Closed and Made Tamper Proof
6	Pull Termination Box, 12" x 26" x 6", Rain-Tight, Circle A-W Catalog Number R-90008, or Equivalent (see Note 4K on Page 2)

<sup>1</sup> Fifth jaw accessory, use Cooper B-Line Cat. No. 50365.

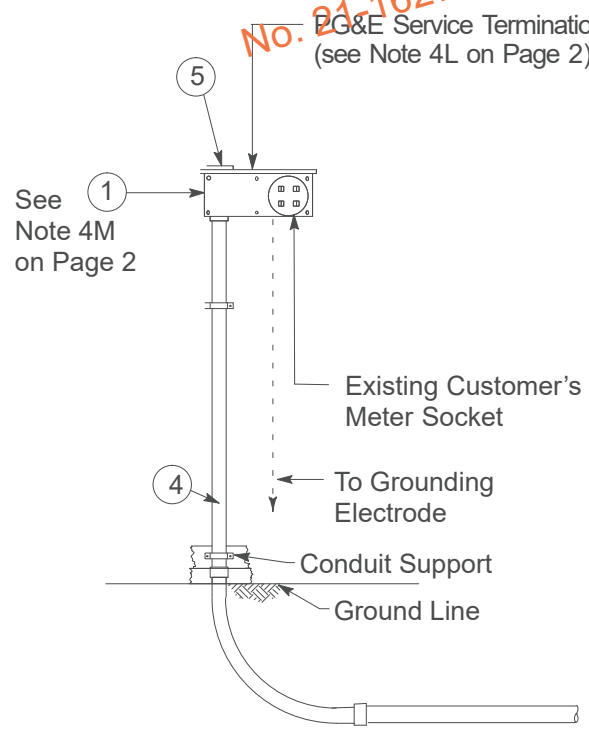
<sup>2</sup> Reducer hub and gasket accessories for 2" conduit, use Cooper B-Line Cat. No. AW200 and 12750A.

Residential and Small Commercial Overhead to Underground Electric Service Conversion

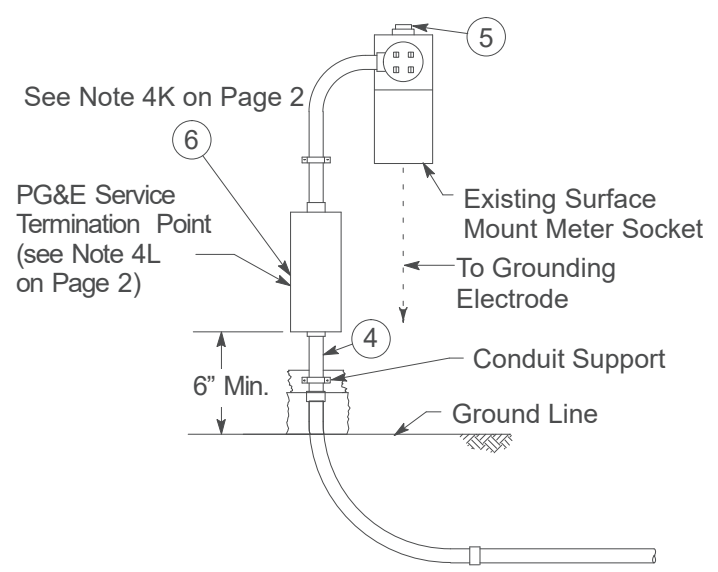


*cited in Cal. Rest. Ass'n v. City of Berkeley No. 21-16278am archived December 27, 2023*

**Figure 1**  
Typical Service Conversion

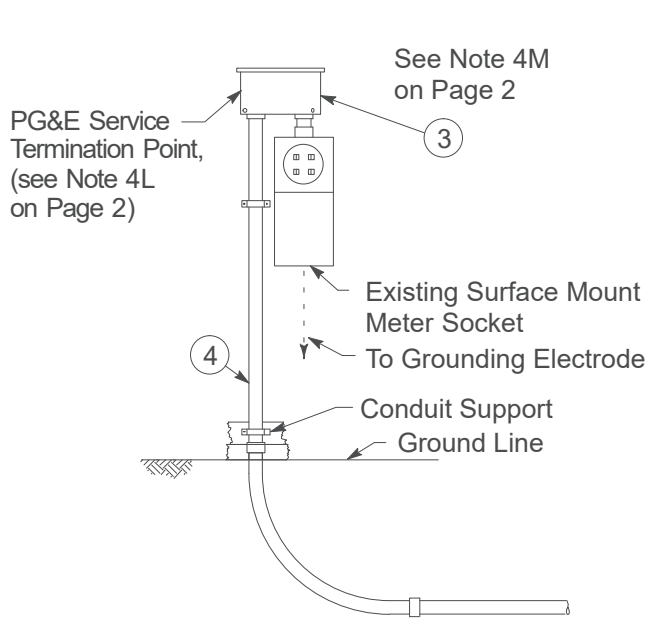


**Figure 2**  
Cooper B-Line Meter Adapter

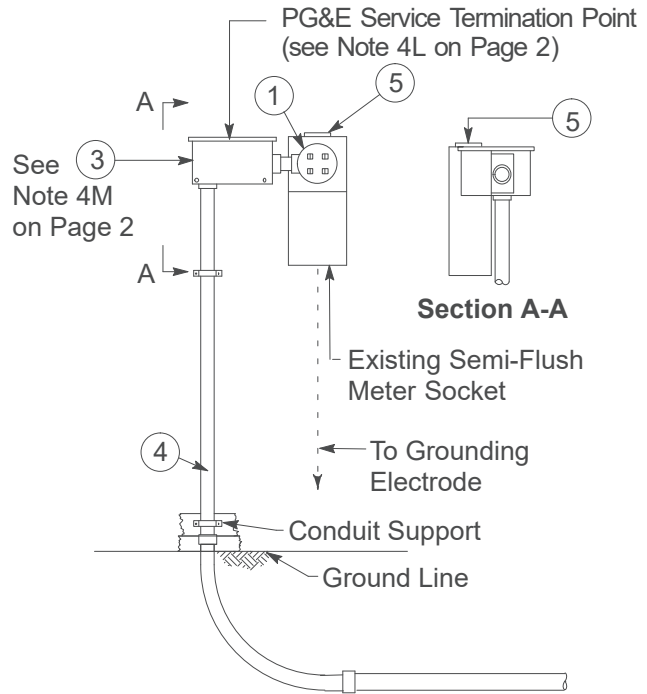


**Figure 3**  
Surface Mount Meter Socket

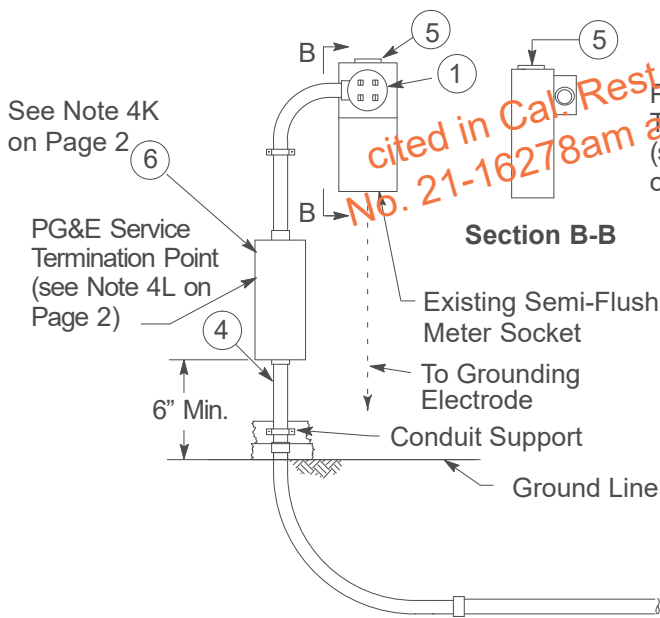
### Residential and Small Commercial Overhead to Underground Electric Service Conversion



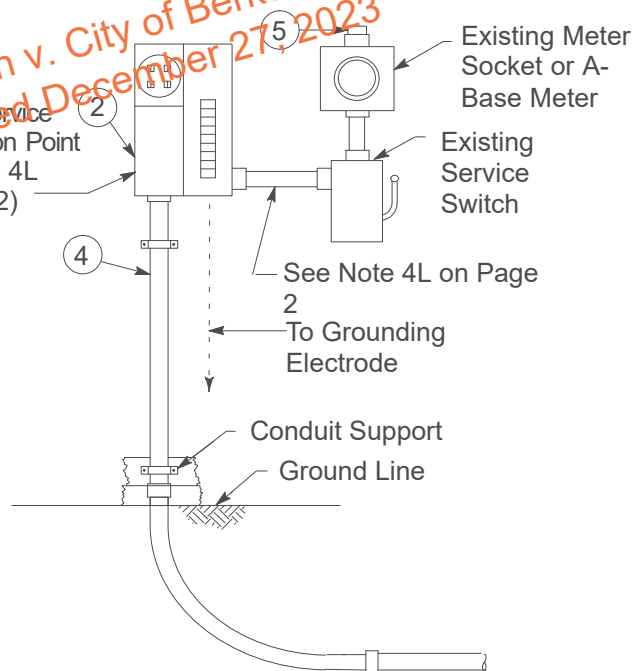
**Figure 4**  
**Surface Mount Meter Socket**



**Figure 5**  
**Semi-Flush Meter Socket**



**Figure 6**  
**Semi-Flush Meter Socket**




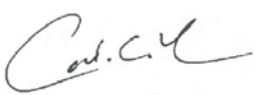
**Figure 7**  
**2-Wire or A-Base Meter Connection**

#### Revision Notes

Revision 04 has the following changes:

1. Revised Note 4G on Page 1.
2. Revised Table 1 and Note 4H, and added Note 4N on Page 2.
3. Revised minimum depth and radius bend in Figure 1 on Page 3.
4. Added Figure 2 on Page 3 with new B-Line meter adapter.

Prepared by: MZGD

	<b>PRIMARY ELECTRIC UNDERGROUND ENCLOSURES</b>	<b>062000</b>
<b>Asset Type:</b> Electric Distribution		<b>Function:</b> Design and Construction
<b>Issued by:</b> Calvin Yu (CCY6)		<b>Date:</b> 03-25-22
<b>Rev. #25:</b> This document replaces PG&E Document 062000, Rev. #24 For a description of the changes, see Page 26.		

**Purpose and Scope**

This document provides dimensions, illustrations, and ordering information for surface-operable, primary, electric underground equipment and splice enclosures including frame and cover assemblies. The primary enclosures shown in this document are the preferred enclosures. Precast and poured-in-place manholes should be used only when space for surface-operable enclosures cannot be obtained.

**General Information**

1. Monolithically poured concrete enclosures may be provided by the supplier, for any depth combination of body and extension, if the enclosure is delivered "in-hole" by the supplier and the enclosure accommodates the approved frame and cover assembly by matching the dimensional requirements herein. Precast and poured-in-place enclosures shall meet the requirements herein.
2. Size all enclosures to accommodate the largest size cable or piece of equipment that may ultimately be installed for 600-Amp and 200-Amp distribution circuits.
3. The greatest cost savings is achieved by taking delivery of the enclosure at the jobsite and using supplier's equipment to install the enclosure into the prepared excavation.
4. Design, design loads, concrete, and reinforcing steel materials, concrete mixes, frame and cover assemblies and materials, and construction of enclosures shall meet the requirements of ASTM C858 and ASTM C857 as modified herein, in the [Engineered Material Specification No. 53](#).
5. It is the responsibility of the installing party to check and prepare the jobsite as follows:
  - A. Make space available for the supplier's equipment and/or a crane.
  - B. Arrange for the removal of any overhead facilities that might prohibit the use of the supplier's equipment and/or crane (if necessary).
  - C. Provide the excavation in the proper location and of the correct size, depth, and alignment, dewatered as needed.
  - D. Prepare the excavation with 6 inches of 1" minimum drain rock (1" to 2" is acceptable). 1.5" to 2" drain rock can be used in soggy soil conditions to prevent settling of the enclosure. Drain rock can be crushed or round, but fines should be avoided. Provide backfilling, tamping, and resurfacing to ensure uniform distribution of soil pressure on floor.
  - E. Provide for waterproofing and protection board where required by [Document 072149](#).
  - F. Provide the necessary manpower to assist in the installation of the enclosure.
6. Mastic sealant is to be provided by the supplier for all concrete-to-concrete joints. Mastic sealant must be installed for all concrete-to-concrete joints.
7. Install enclosure body as level as practical, but do not exceed 1/8" elevation change per foot. Use adjustment bolts to adjust the cover to final grade. Grout the frame continuously 360° to the enclosure. If grade adjustment bolts are used, remove bolts after grouting.
8. **Do not** break out the bottom of the sump hole. The drain rock is for leveling the enclosure, not for drainage.



## Primary Electric Underground Enclosures

9. The enclosures in this document are equipped with conduit terminators. Secondary conduits may enter the terminators with 21" to 24" of cover at the entrance of the enclosures. When entering these enclosures with conduit of a different diameter than the terminator, use a swedge reducer ([Document 062288](#)) not to be installed closer than 18" to the terminator. New enclosure designs no longer have knockout windows. Conduits entering through knockout windows on existing enclosures should use end bells and grout. Conduits must be straight with no bends, couplings, or swedge reducers for 18".
10. Every effort should be made to route all conduits through the short walls of the enclosure to facilitate cable pulling. Long wall entry should only be used when all other options have been exhausted.
11. Core drilling at the enclosure wall beyond designated knockout window(s) for installation of additional conduits is not allowed.
12. Pulling irons shall be designed for 20,000 pounds ultimate, with a safety factor of two (40,000 pounds).
13. Lifting
  - A. All extensions and heavy full traffic covers shall be provided with four 7/8-inch diameter, 2-1/4-inch minimum deep inserts with unified coarse thread, Class 2A threads.
  - B. Boxes shall be lifted using pulling irons in the floor.
14. Marking
  - A. All covers shall be marked with one "High Voltage" and three blank number ID plates in accordance with [Document 051768](#).
  - B. All covers shall be permanently marked on the underside with the manufacturer's name and the date of the manufacturer in this format: mm/yy.
  - C. All concrete parts shall be permanently identified with the manufacturer's name on the inside and outside surfaces.
  - D. All concrete parts shall have the weight stenciled on the outside surface.
15. All bodies and extensions shall conform to the dimensional specifications so as to be fully interchangeable with the bodies and extensions of all other manufacturers.
16. Custom extensions made of bricks, Concrete Masonry Units (CMU, aka cinder blocks, cement blocks, etc), Cast-In-Place plain concrete, or other conventional materials are not allowed. Install only the PG&E coded materials or custom extensions by PG&E approved manufacturers.
17. All covers shall have a PG&E-approved high coefficient of friction (0.65 or better), slip-resistant surface.
18. The following parts of the frame and cover assembly shall conform to the dimensional specifications and the applicable PG&E standards so as to be compatible with the frame and cover assemblies of any approved manufacturer.
  - A. Viewport (Refer to [Document 066205](#))
  - B. Identification Plates (Refer to [Document 051768](#))
  - C. Replacement Bolt Down Assembly (M040586). This assembly is part of the cover release locking mechanism.
19. Each approved manufacturer of frame and cover assemblies shall maintain dimensional consistency between all the parts of the frame and cover assembly such that replacement parts will be compatible with that manufacturer's existing assemblies in use in the field.
20. Grounding is required for all new primary concrete enclosures. Grounding is highly recommended to be added to existing primary enclosures. For grounding requirements of the enclosure refer to [Document 060462](#).
21. Drawings are intended to be generic for the various approved enclosure and cover manufacturers. Appearances may vary slightly. All approved enclosures are compatible with all approved frame and cover assemblies.

**Application**

22. Incidental-vehicular-traffic (IVT) ([ASTM C-857](#), Rating H-10-44, light traffic): For use in sidewalks, paved and unpaved pedestrian areas, parkway strips adjacent to curbs, and any other area subject to occasional vehicular traffic not to exceed 10 tons gross vehicle weight (GVW) or 10 mph speed limits.
  - A. IVT covers installed in commercial districts, urban environments, areas with congested parking conditions, or any area where it can be expected or observed that vehicles park or drive on these locations with any regularity should consider the use of the FVT cover instead in order to prevent damage to the enclosure.

## Primary Electric Underground Enclosures

23. Full-vehicular-traffic (FVT) ([ASTM C-857](#), Rating HS-20-44, full traffic): Quick-release covers designed for H-20 vehicular wheel load but not subject to high-density traffic with speed higher than 25 mph; locations such as alleys, driveways, parking strips, etc.
24. Heavy full-vehicular-traffic (HFVT) ([ASTM C-857](#), Rating HS-20-44, heavy traffic): For use in streets and all other areas subject to vehicular traffic in excess of 10 tons GVW, but not to exceed 20 tons GVW. Entrance into this type of enclosure shall not be made through an opened gate.
25. Heavy full-vehicular-traffic (HFVT) enclosures are not to be used to install sectionalizing equipment (including switching devices and automatic interrupters) or transformers, except on projects where a location for an incidental-vehicular-traffic box is not available. Do not install HFVT enclosures in new business jobs unless all other options have been exhausted and PG&E has agreed to its installation.
- A. Due to the entry restrictions of this enclosure and the requirement to remove the entire concrete cover to access, the HFVT enclosure may not be placed in a location where overhead obstacles or facilities pose a safety risk when using lifting equipment.
26. Separation of enclosures from wet and non-utility facilities (Similar to Section C of UO Standard S5453):
- A. The maximum practicable horizontal separation shall be maintained between the outer edge of the new primary enclosures and the outer edge of parallel existing "wet" utilities. The minimum allowable separation between the enclosures and "wet" facilities is 3' with the presence of a minimum of 1' of undisturbed earth or the installation of a suitable concrete barrier.
- B. In the extraordinary case that the minimum 3' horizontal separation cannot be attained between "wet" utilities and the enclosures, a variance may be recommended by the local Inspection Supervisor and submitted to Engineering Standards for approval. In no case will a separation of less than 1' be allowed.
- C. The minimum 3' horizontal separation requirement may be allowed as a variance, at the request of an applicant if warranted and the need is clearly demonstrated. The request for a variance must:
- Be made in writing and submitted to the Company ADE during the planning and design phase of the project.
  - Clearly describe the conditions necessitating the variance.
  - Include a proposed design.
  - And, include a mitigation proposal to provide a concrete barrier between the "wet" utilities and the enclosures in the event 3' horizontal separation cannot be maintained.
27. Enclosures with drag-off style covers which are also in close proximity to other potential fall hazards, such as other enclosures or uneven terrain, or which are lacking standard support beams, must be changed when doing any work other than routine switching in that enclosure. For drag-off cover replacement requirements refer to Note 9 to 11 of [Document 066205](#).

References	Location	Document
<a href="#">Cable Support for Underground Use</a>	<a href="#">UG-1: Splices</a>	<a href="#">028077</a>
<a href="#">Identification Plates for Subsurface Enclosures</a>	<a href="#">UG-1: Marking</a>	<a href="#">051768</a>
<a href="#">Duplex-Type, Three-Phase, Subsurface Transformer</a>	<a href="#">UG-1: Transformers</a>	<a href="#">051776</a>
<a href="#">Grounding of Underground Equipment</a>	<a href="#">UG-1: General</a>	<a href="#">060462</a>
<a href="#">Underground Conduits</a>	<a href="#">UG-1: Conduits</a>	<a href="#">062288</a>
<a href="#">Enclosure Repair/Replacement Criteria and Replacement Materials</a>	<a href="#">UG-1: Enclosures</a>	<a href="#">066205</a>
<a href="#">Requirements for Allowing Installation of Subsurface Transformers</a>	<a href="#">UG-1: General/Greenbook</a>	<a href="#">072149</a>
<a href="#">Design Requirements for Primary Electric Distribution Underground Concrete Enclosures</a>	<a href="#">TIL</a>	<a href="#">EMS53</a>

## Primary Electric Underground Enclosures

Table 1 Enclosure and Excavation Sizes for New Installations of Subsurface Equipment

Application	Location		Enclosure Size <sup>4</sup>	Excavation Size <sup>1</sup>	
	Incidental and Full Traffic	Heavy Full Traffic Allowed		Incidental and Full Traffic	Heavy Full-Traffic
200-Amp Cable and Non-Lead Splices <sup>5</sup>	Yes	Yes	3' x 5' x 3' 6"	5' x 7' x 5'	5' x 7' x 6'
200-Amp Junctions		No	4' x 6' 6" x 5'	6' x 8' 6" x 6' 6"	-
200-Amp Sectionalizing Switches		Yes <sup>2</sup>	4' x 6' 6" x 5'	6' x 8' 6" x 6' 6"	6' x 8' 6" x 7' 6"
200-Amp Subsurface Fused Switches		No	4' x 6' 6" x 5'	6' x 8' 6" x 6' 6"	-
200-Amp Automatic Interrupter		No	4' x 6' 6" x 5'	6' x 8' 6" x 6' 6"	-
1Ø Horizontal Transformers		Yes <sup>2</sup>	4' x 6' 6" x 5'	6' x 8' 6" x 6' 6"	6' x 8' 6" x 7' 6"
1Ø Round Transformers		Yes <sup>2</sup>	4' x 6' 6" x 6'	6' x 8' 6" x 7' 6"	6' x 8' 6" x 8' 6"
600-Amp Separable Connectors		No	4' 6" x 8' 6" x 6'	6' 6" x 10' 6" x 7' 6"	-
600-Amp Sectionalizing Switch		Yes <sup>2</sup>	4' 6" x 8' 6" x 6'	6' 6" x 10' 6" x 7' 6"	-
600-Amp Scada Switch		No	4' 6" x 8' 6" x 6'	6' 6" x 10' 6" x 9'	-
600-Amp Automatic Interrupter		No	4' 6" x 8' 6" x 6'	6' 6" x 10' 6" x 7' 6"	-
3Ø Duplex Transformer <sup>3</sup>		Yes <sup>2</sup>	4' 6" x 8' 6" x 6'	6' 6" x 10' 6" x 7' 6"	6' 6" x 10' 6" x 8' 6"
3Ø UCD (112.5 through 1,000 kVA)		Yes <sup>2</sup>	4' 6" x 8' 6" x 7' 6"	6' 6" x 10' 6" x 9'	6' 6" x 10' 6" x 10'

<sup>1</sup> Depth allows for 6" of drain rock, per Note 5D. on Page 1.

<sup>2</sup> Installing this equipment in heavy full-traffic enclosures is the least desirable option, and should only be considered on reconstruction projects where suitable locations for incidental and full vehicle traffic boxes are not available. Refer to Item 25 in the Application section of this document.

<sup>3</sup> See [Document 051776](#).

<sup>4</sup> The 12" extension that is included in the heavy full-traffic assembly is not listed in this column.

<sup>5</sup> Installation of a 3'x5'x3'6" enclosure for straight splices is only allowed if no future expansion is expected that would require a transformer, junction, or switch to be installed in that enclosure.

<sup>6</sup> 1Ø Round transformers require a 6' deep enclosure; add a 12" extension to the standard enclosure.

## Primary Electric Underground Enclosures

---

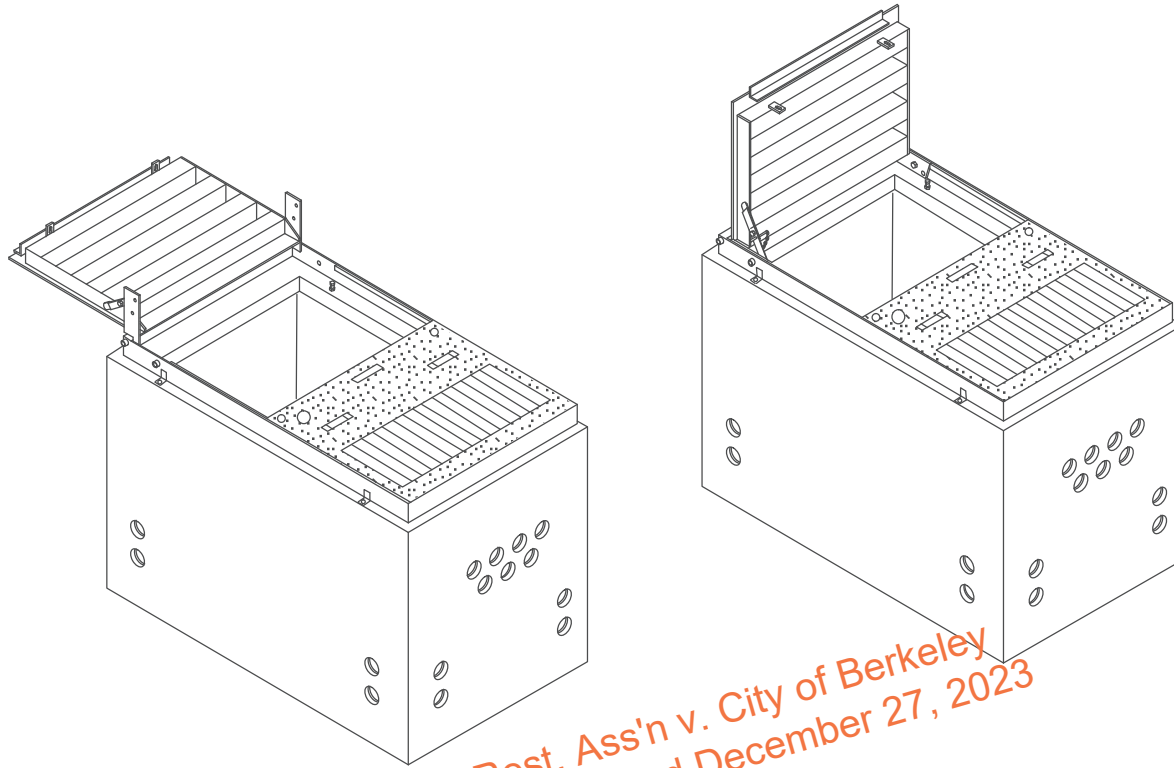
### Notes

1. Existing 3' x 5' (#5) enclosure with minimum 36" depth will continue to be allowed when:
  - A. Replacing existing 200-Amp splice junction, and equipment.
  - B. Converting existing 200-Amp splices to a 200-Amp junction.
2. When intercepting existing 200-Amp primary cable to install 200-Amp equipment, the installation of a 3' x 5' (#5) enclosure will only be allowed if there is no physical space for the installation of a 4' x 6' 6" (#6) enclosure and all other design alternatives have been exhausted. However, installation of 167 kVA single phase transformers requires a 4' x 6' 6" (#6) enclosure.
3. The installation of new 200-Amp junction and equipment is not allowed in new 3' x 5' (#5) primary enclosure for **new** PG&E job estimates or Applicant Design (AD) estimates.

*cited in Cal. Rest. Ass'n v. City of Berkeley  
No. 21-16278am archived December 27, 2023*

### Primary Electric Underground Enclosures

#### 3' 0" x 5' 0" (#5) Complete Enclosure Assemblies (incidental transformer cover shown)



*cited in Cal. Rest. Ass'n v. City of Berkeley  
No. 21-16278am archived December 27, 2023*

**Figure 1**  
Isometric View of 3' x 5' Enclosure Assembly  
(not to scale)

**Table 2 Complete Enclosure Assembly (for 200-Amp distribution)**

Application	Enclosure Size	Type of Traffic Loading	Type of Cover <sup>2</sup>	Code <sup>1</sup>
Splice Box	3' x 5' x 3' 6"	Incidental	Quick-Release Aluminum	025601
	3' x 5' x 3' 6"	Full-Traffic	Quick-Release Steel	041668
	3' x 5' x 4' 6"	Heavy Full-Traffic	Concrete	041612
	3' x 5' x 4' 6"	Incidental	Quick-Release Aluminum	040334
	3' x 5' x 4' 6"	Full-Traffic	Quick-Release Steel	041669
	3' x 5' x 5' 6"	Heavy Full-Traffic	Concrete	040327

<sup>1</sup> Code includes body, frame, and cover assembly. The heavy full-traffic assembly also includes a 12" extension. When extra depth is required, order additional extension from Table 3 on Page 7.

<sup>2</sup> Transformer covers for 3' x 5' (#5) boxes are not available for new construction. Replacement cover material can be found in [Document 066205](#).

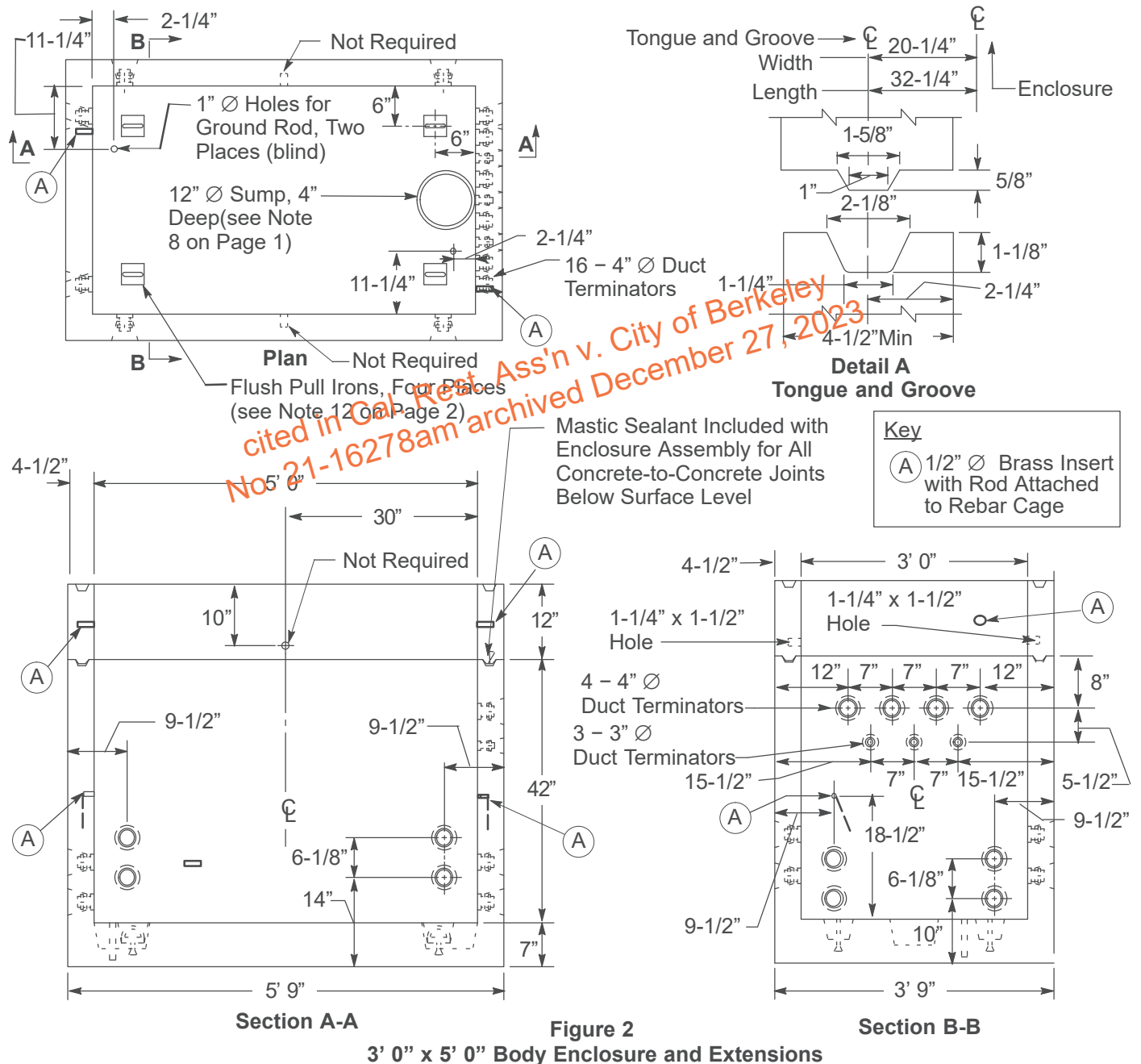
Primary Electric Underground Enclosures

3' 0" x 5' 0" (#5) Enclosure and Extensions

Table 3 Codes for Enclosure Bodies and Extensions (see Figure 2)

Description	Code	Weight - Approximate (lbs.)
Body, 42" Depth	043361	5,940
Body, 54" Depth	043588	7,060
Extension, 6" Depth <sup>1</sup>	043197	560
Extension, 12" Depth <sup>1</sup>	043362	1,130
Extension, 18" Depth <sup>1</sup>	040578	1,690
Extension, 24" Depth <sup>1</sup>	043531	2,250

<sup>1</sup> Joints must be interchangeable with those shown in Detail A and approved by PG&E electric distribution personnel.



### Primary Electric Underground Enclosures

## 3' 0" x 5' 0" (#5) Aluminum Quick Release Cover Assembly – Incidental Traffic

Table 4 Complete Frame and Cover Assembly

Type of Enclosure	Type of Traffic Loading	Type of Cover	Code
Splice Box	Incidental	Quick-Release Aluminum	025604
	Full-Traffic <sup>1</sup>	Quick-Release Steel	041052
	Heavy Full-Traffic	Concrete	041616

<sup>1</sup> For application guide, see Note 23 on Page 3.

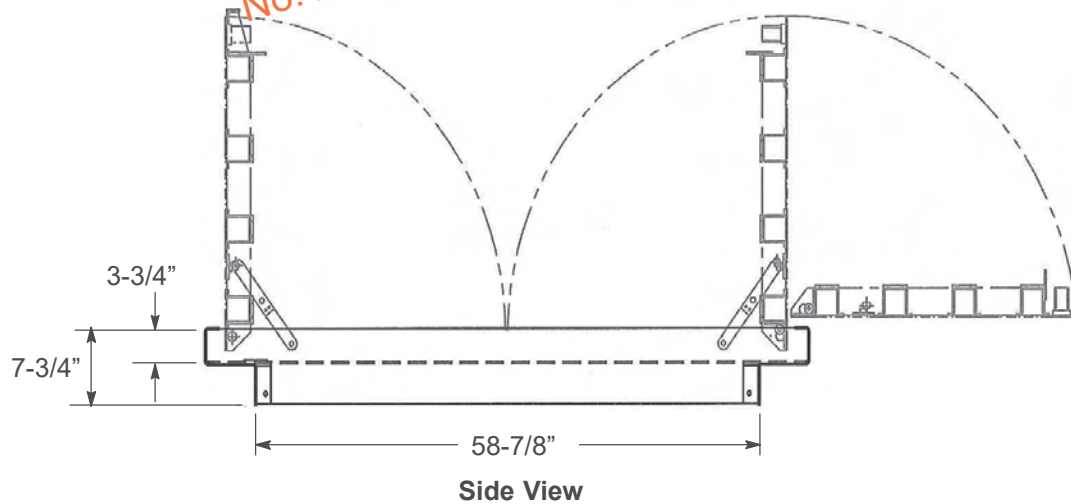
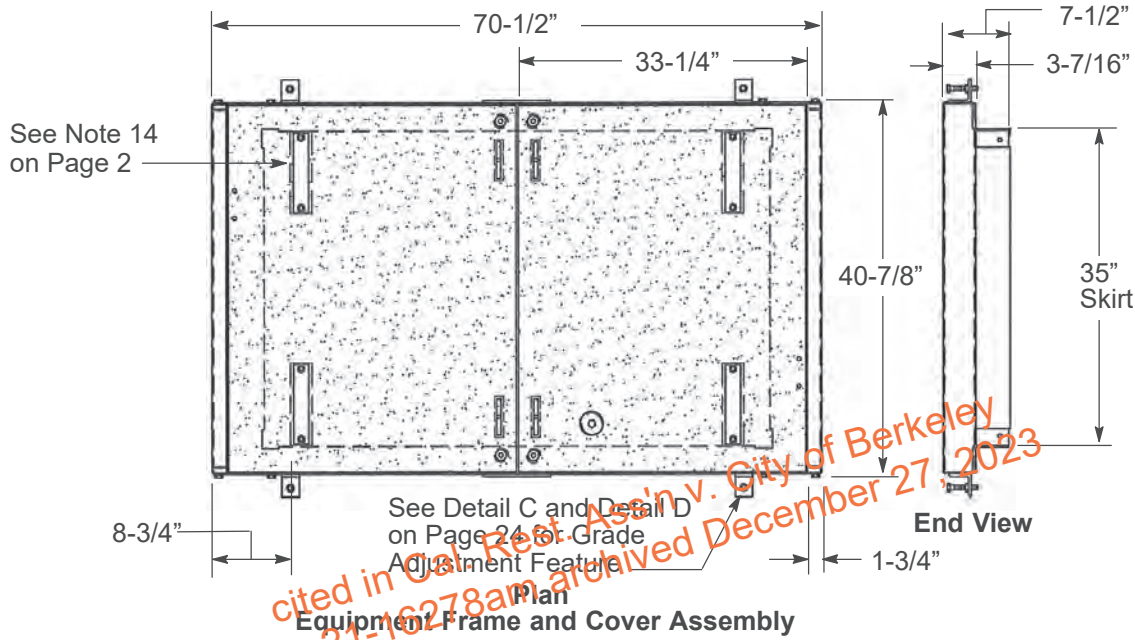


Figure 3  
3' 0" x 5' 0" Quick Release Cover Assembly – Incidental Traffic

Primary Electric Underground Enclosures

3' 0" x 5' 0" (#5) Steel Quick-Release Cover Assembly – Full Traffic

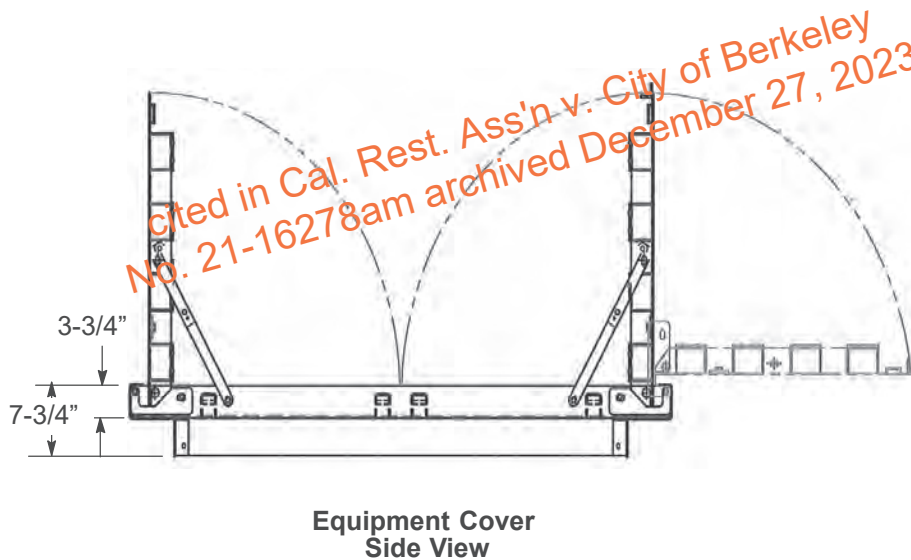
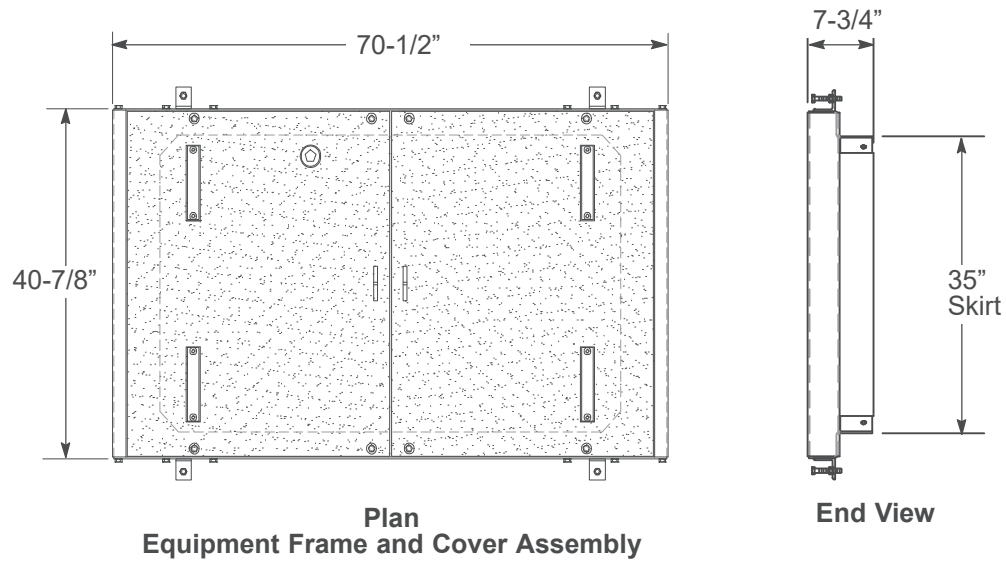
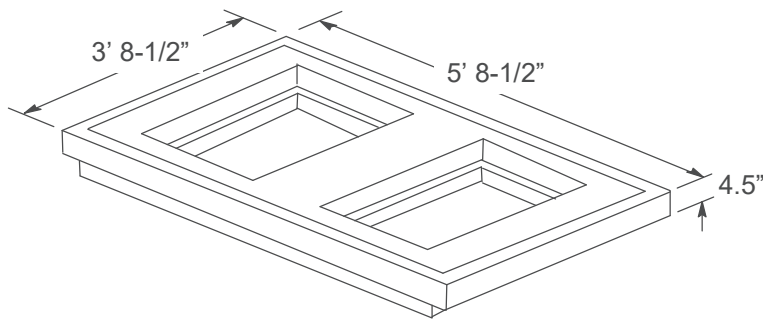


Figure 4  
3' 0" x 5' 0" Quick-Release Cover Assembly - Full Traffic

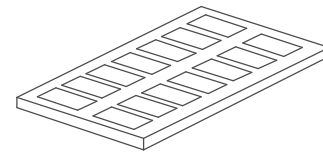


### Primary Electric Underground Enclosures

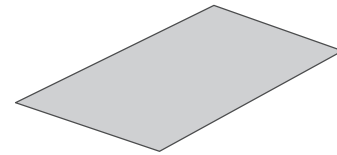
#### 3' 0" x 5' 0" (#5) Heavy Full-Traffic Cover Assemblies



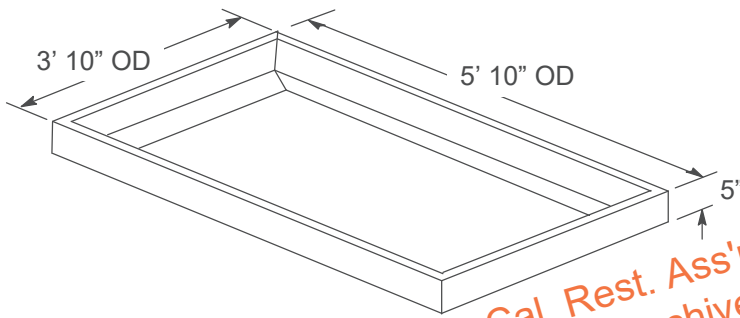
Heavy Full-Traffic Cover



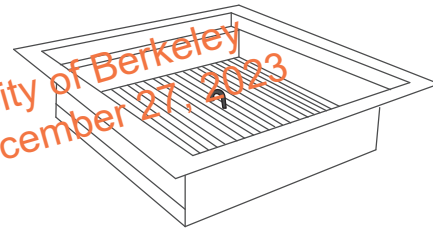
Grated Heavy Full-Traffic Cast Iron Insert



Solid Heavy Full-Traffic Cast Iron Insert



Heavy Full-Traffic Frame



Baffle

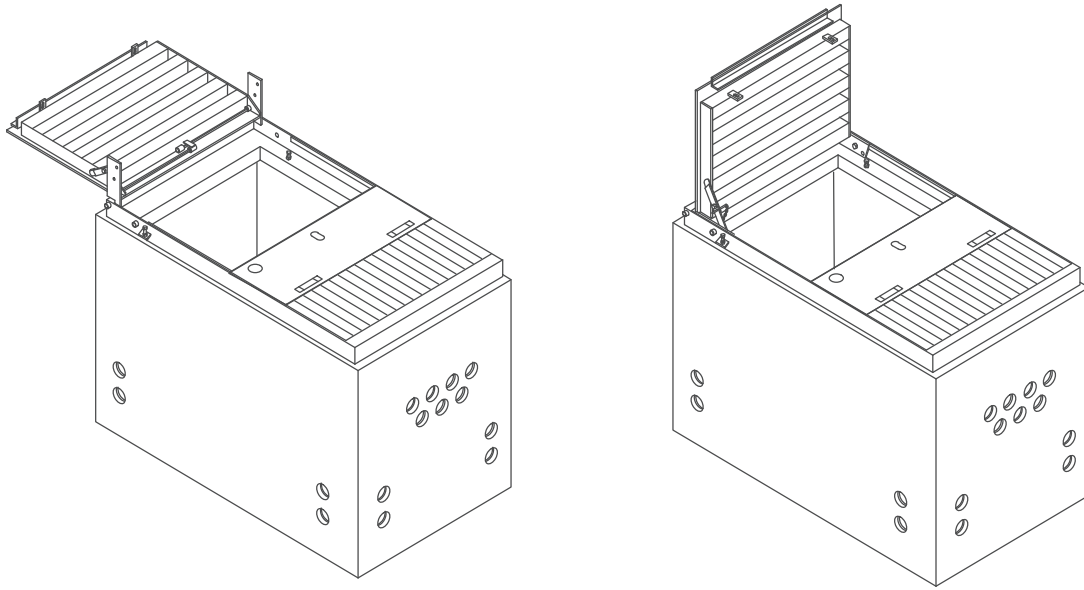
*cited in Cal. Rest. Ass'n v. City of Berkeley  
No. 21-16278am archived December 27, 2023*

**Figure 5**  
**3' 0" x 5' 0" Heavy Full-Traffic Cover Assemblies**

**Table 5 Component Parts**

Description	Weight	Code
3' x 5' HFVT, Concrete Cover Without Inserts	1,160 lbs.	040338
3' x 5' HFVT, 5' x 5' x 1/2" Steel Frame With Adjustment Feature	290 lbs.	040339
Cast Iron Grate Inserts for Transformer Enclosures	120 lbs.	040346
Cast Iron Solid Inserts for Splice/Equipment Enclosures	180 lbs.	040343
Baffle	25 lbs.	360036

## Primary Electric Underground Enclosures

**4' 0" x 6' 6" (#6) Complete Enclosure Assemblies (incidental transformer shown)**

**Figure 6**  
Isometric View of 4' 0" x 6' 6" Enclosure Assembly  
(not to scale)

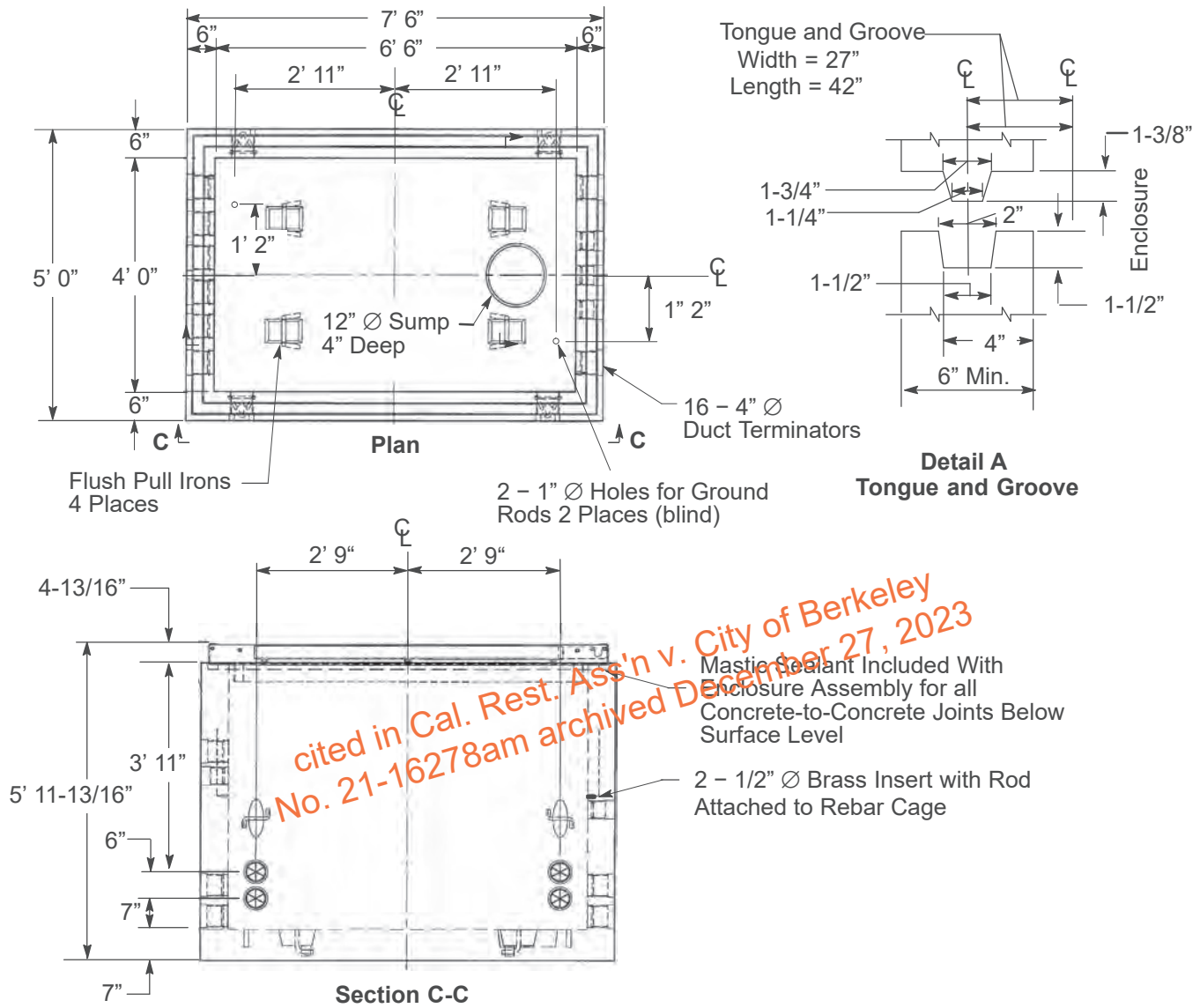
**Table 6 Complete Enclosure Assembly (for 200-amp distribution)**

Application	Enclosure Size	Type of Traffic	Type of Cover	Code <sup>1</sup>
1Ø Horizontal Transformers	4' 0" x 6' 6" x 5' 0"	Incidental	Quick-Release Aluminum	041492
	4' 0" x 6' 6" x 5' 0"	Full-Traffic	Quick-Release Steel	041493
	4' 0" x 6' 6" x 6' 0"	Heavy Full-Traffic	Concrete	041494
Equipment/Splice Box	4' 0" x 6' 6" x 5' 0"	Incidental	Quick-Release Aluminum	041495
	4' 0" x 6' 6" x 5' 0"	Full-Traffic	Quick-Release Steel	041496
	4' 0" x 6' 6" x 6' 0"	Heavy Full-Traffic	Concrete	041521

<sup>1</sup> Code includes body, frame, and cover assembly. The heavy full-traffic assembly also includes a 12" extension. When extra depth is required, order additional extension from Table 7 on Page 12.

### Primary Electric Underground Enclosures

#### 4' 0" x 6' 6" (#6) Enclosure and Extensions



*cited in Cal. Rest. Ass'n v. City of Berkeley  
No. 21-16278am archived December 27, 2023*

Mastic Sealant Included With Enclosure Assembly for all Concrete-to-Concrete Joints Below Surface Level

2 - 1/2" Ø Brass Insert with Rod Attached to Rebar Cage

Figure 7  
4' 0" x 6' 6" Body Enclosure

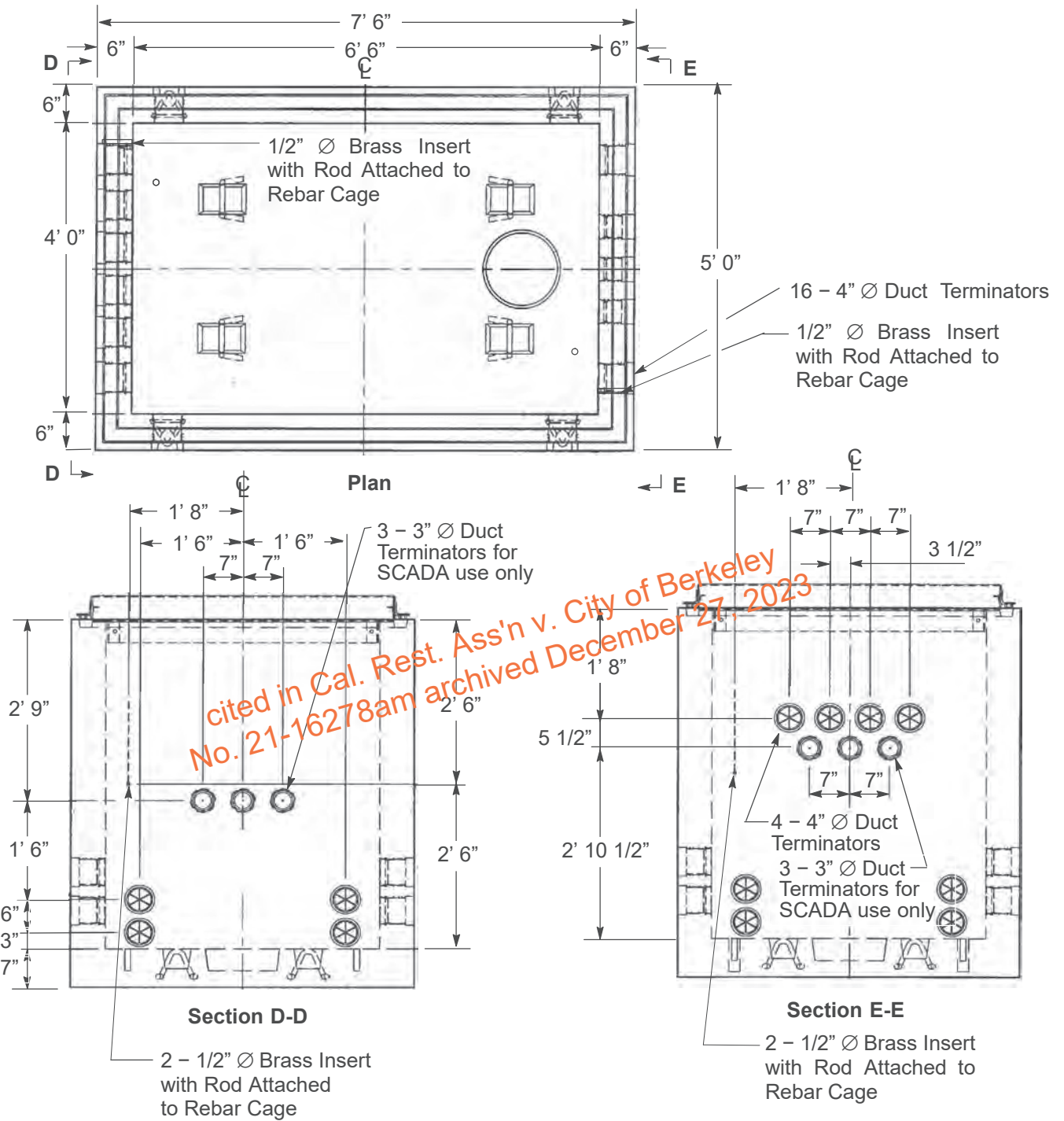
Table 7 Codes for Enclosure Bodies and Extensions (Figure 7)

Item	Description	Code	Weight - Approximate (lbs.)
1	Body, 60" Depth	041567	11,750
2	Extension, 6" Depth <sup>1</sup>	041569	800
3	Extension, 12" Depth <sup>1</sup>	041570	1,600
4	Extension, 18" Depth <sup>1</sup>	041574	2,400

<sup>1</sup> Joints must be interchangeable with those shown in Detail A on Page 12 and approved by PG&E electric distribution personnel.

Primary Electric Underground Enclosures

4' 0" x 6' 6" (#6) Enclosure and Extensions (continued)

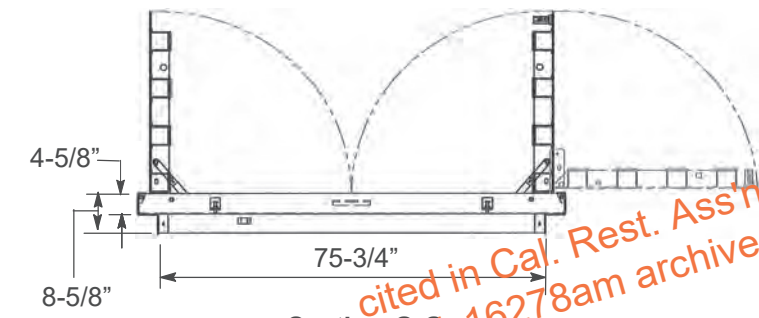
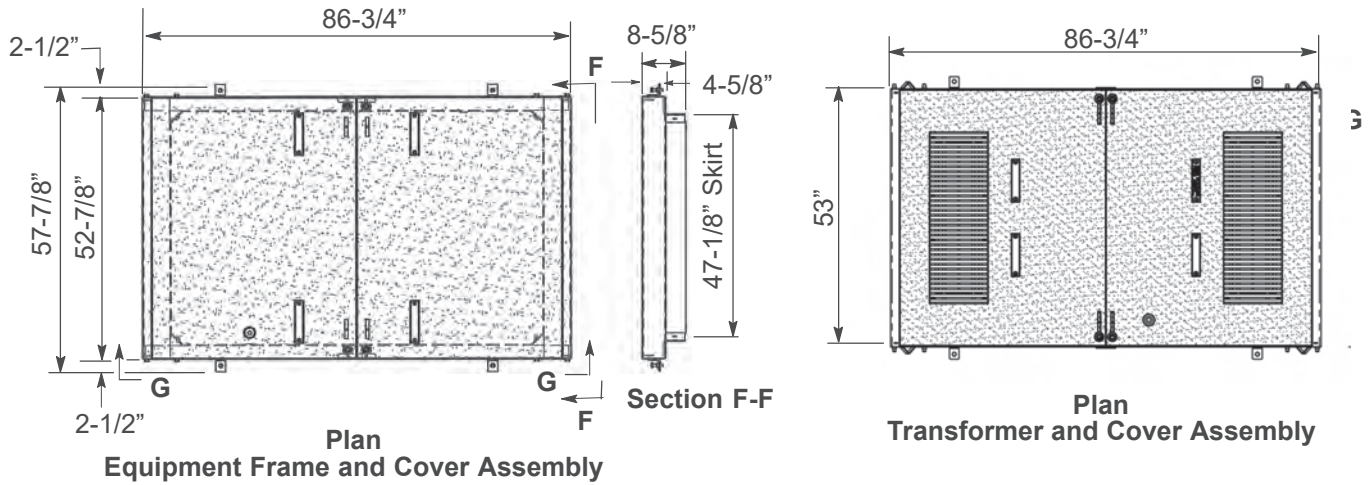


*cited in Cal. Rest. Ass'n v. City of Berkeley  
No. 21-16278am archived December 27, 2023*

Figure 8  
4' 0" x 6' 6" Body Enclosure

Primary Electric Underground Enclosures

4' 0" x 6' 6" (#6) Aluminum Quick-Release Cover Assembly – Incidental Traffic



Side View of Equipment Frame and Cover Assembly  
Dimensions for Transformer Frame and Cover Assembly  
Same as Detailed

Figure 9  
4' 6" x 6' 6" Quick-Release Cover Assembly – Incidental Traffic

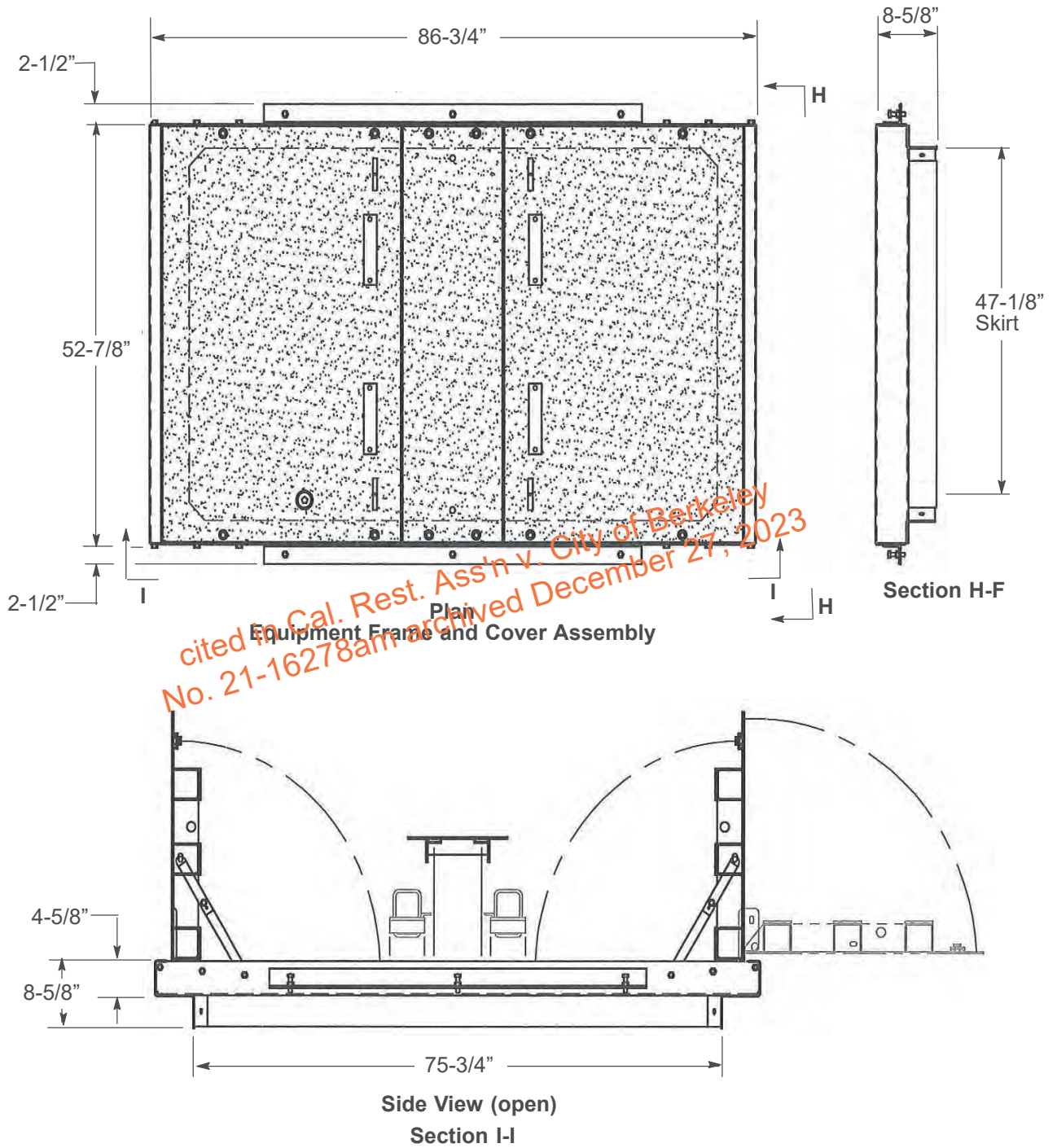
Table 8 Complete Frame and Cover Assembly

Type of Enclosure	Type of Traffic	Type of cover	Code
1Ø Horizontal Transformers	Incidental	Quick-Release Aluminum	041092
	Full-Traffic <sup>1</sup>	Quick-Release Steel	360148
	Heavy Full-Traffic	Concrete	041541
Equipment/Splice Box	Incidental	Quick-Release Aluminum	041093
	Full-Traffic <sup>1</sup>	Quick-Release Steel	360149
	Heavy Full-Traffic	Concrete	041557

<sup>1</sup> For application guide, see Note 23 on Page 3.

Primary Electric Underground Enclosures

4' 0" x 6' 6" (#6) Steel Quick-Release Cover Assembly – Full Traffic

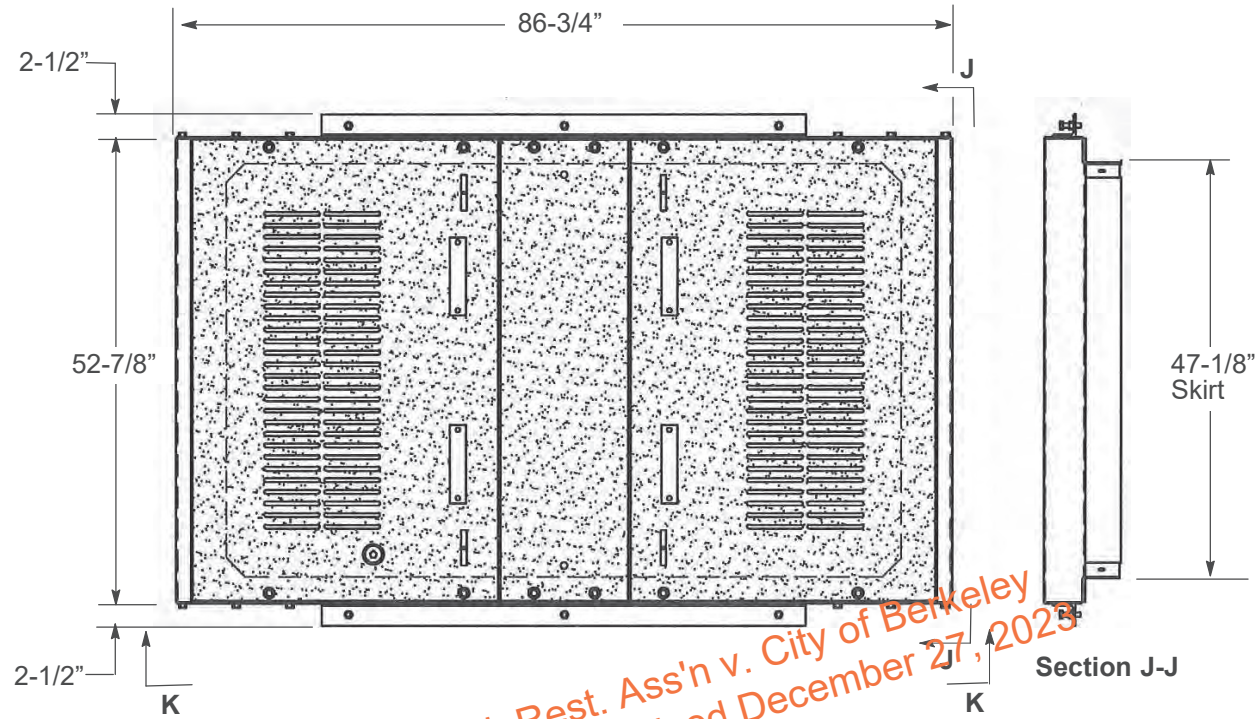


*cited in Cal. Rest. Ass'n v. City of Berkeley  
No. 21-16278am archived December 27, 2023*

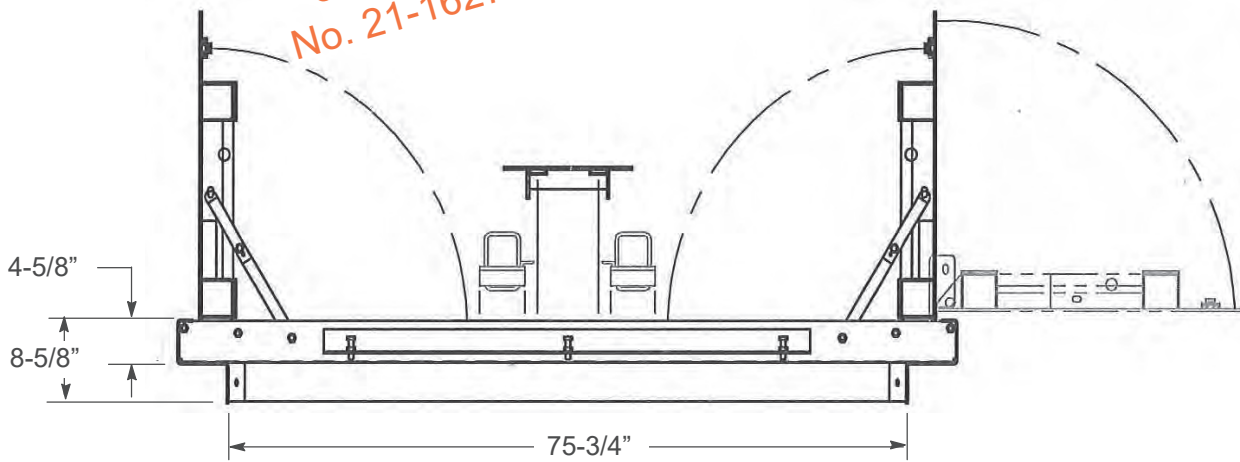
Figure 10  
4' 0" x 6' 6" Steel Quick-Release Cover Assembly – Full Traffic

Primary Electric Underground Enclosures

4' 0" x 6' 6" (#6) Steel Quick-Release Cover Assembly – Full Traffic (continued)



*cited in Cal. Rest. Ass'n v. City of Berkeley  
No. 21-16278am archived December 27, 2023*



Side View (open)  
Section K-K

Figure 11  
4' 0" x 6' 6" Steel Quick-Release Cover Assembly – Full Traffic

Primary Electric Underground Enclosures

4' 0" x 6' 6" (#6) Heavy Full-Traffic Cover Assemblies

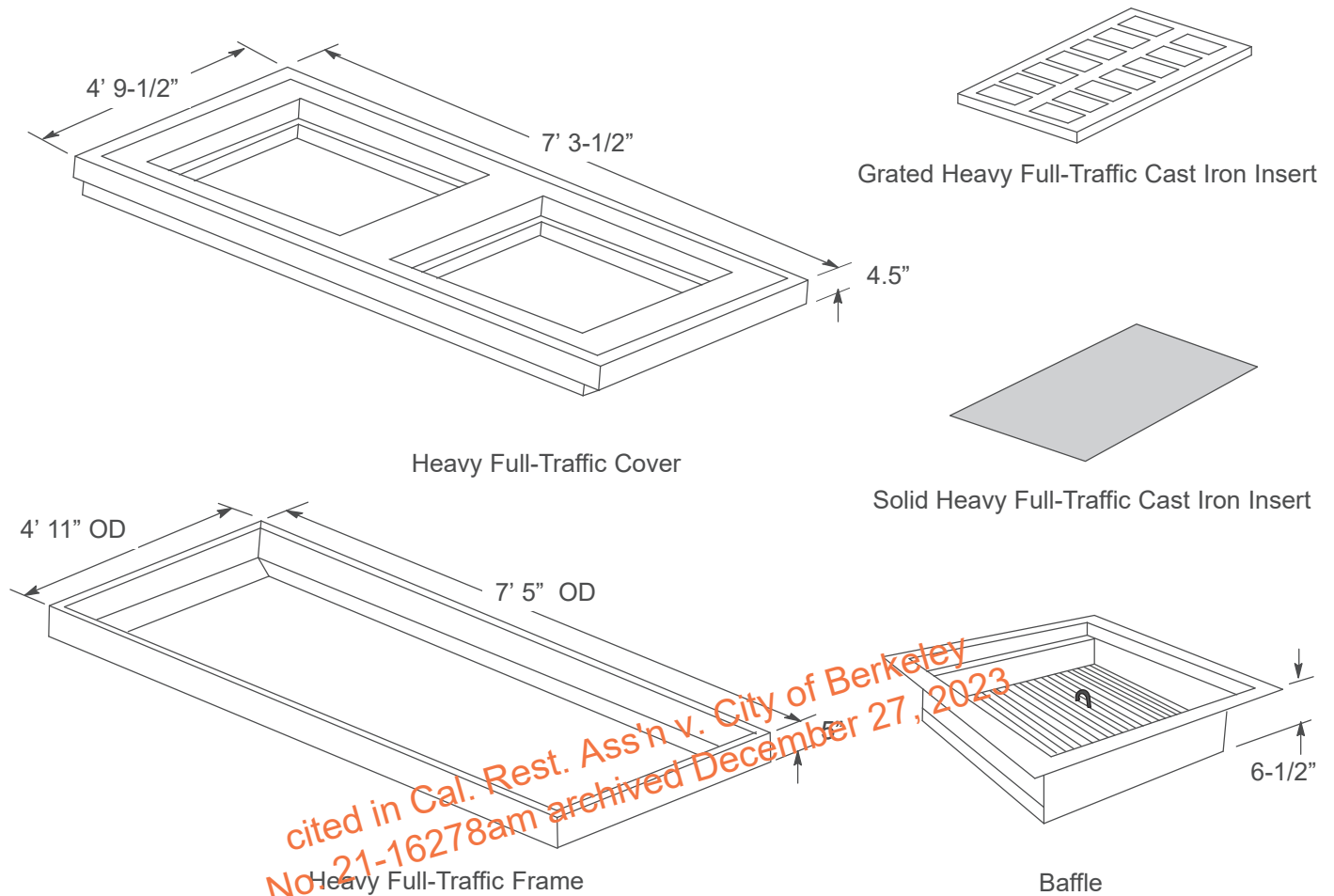


Figure 12  
4' 0" x 6' 6" Heavy Full-Traffic Cover Assembly

Table 9 Component Parts

Description	Weight	Code
4' 0" x 6' 6", HFVT Concrete Cover Without Inserts	3,835 lbs.	041926
4' 0" x 6' 6", HFVT 5' x 5' x 1/2" Steel Frame With Adjustment Feature	339 lbs.	041927
Cast Iron Grate Inserts for Transformer Enclosures	120 lbs.	040346
Cast Iron Solid Inserts for Splice Equipment Enclosures	180 lbs.	040343
Baffle	25 lbs.	360036

Table 10 4' 0" x 6' 6" Cable Tail Lengths for Estimating <sup>1</sup>

4' 0" x 6' 6"	28'
Horizontal TX Enclosure (Sec. Entrance Side)	26' Primary/ 7' Secondary
Horizontal TX Enclosure (Opp. Sec. Entrance Side)	15' Primary/ 15' Secondary

<sup>1</sup> Cable tail length for 3' 0" x 5" 0" and 4' 6" x 8' 6" enclosures are found on the Electric Design Manual under the Underground 10.10 Section, Table 10 - 4.

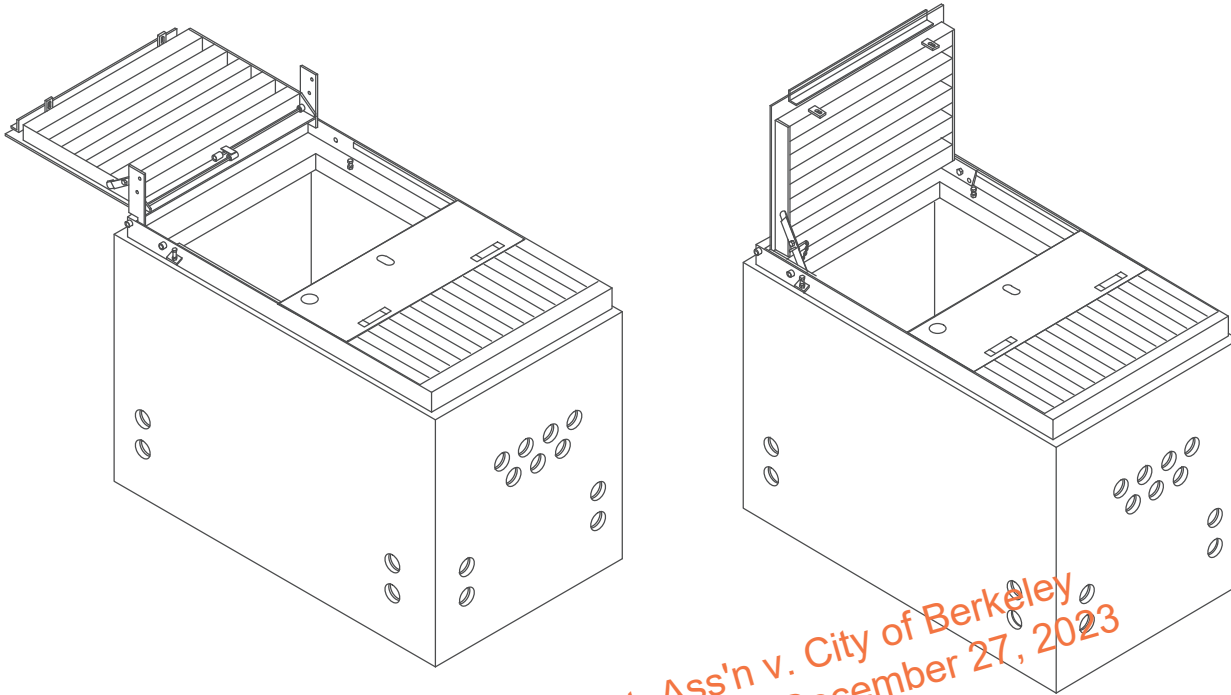


## Primary Electric Underground Enclosures

## 4' 6" x 8' 6" (#7) Complete Enclosure Assemblies

## Notes

- Swedge reducers are necessary with primary conduit smaller than 6 inches (see [Document 062288](#)).



cited in Cal. Rest. Ass'n v. City of Berkeley  
No. 21-16278, amended December 27, 2023

Figure 13  
4' 6" x 8' 6" Enclosure Assembly  
(not to scale)

**Table 11 Complete Enclosure Assembly (for 600-amp distribution)**

Application	Enclosure Size	Type of Traffic	Type of Cover	Code <sup>1</sup>
3Ø Duplex Transformer <sup>2</sup>	4' 6" x 8' 6" x 6' 0"	Incidental	Quick-Release Aluminum	043371
	4' 6" x 8' 6" x 6' 0"	Full-Traffic	Quick-Release Steel	041649
	4' 6" x 8' 6" x 7' 0"	Heavy Full-Traffic	Concrete	041439
Equipment <sup>3</sup>	4' 6" x 8' 6" x 6' 0"	Incidental	Quick-Release Aluminum	043411
	4' 6" x 8' 6" x 6' 0"	Full-Traffic	Quick-Release Steel	041666
	4' 6" x 8' 6" x 7' 0"	Heavy Full-Traffic	Concrete	041441
UCD Transformer <sup>4</sup>	4' 6" x 8' 6" x 7' 6"	Incidental	Quick-Release Aluminum	040325
	4' 6" x 8' 6" x 7' 6"	Full-Traffic	Quick-Release Steel	041662
	4' 6" x 8' 6" x 8' 6"	Heavy Full-Traffic	Concrete	040324

<sup>1</sup> Code includes body, extension (as appropriate), frame, and cover assembly. When extra depth is required, order additional extension from Table 12 on Page 19.

<sup>2</sup> See [Document 051776](#).

<sup>3</sup> 600-amp non-lead splices, 600-amp switches, 600-amp separable connectors.

<sup>4</sup> 112.5 through 500 kVA UCD transformers with 4-hole secondary spades will fit into existing 4' 6" x 8' 6" x 6' 0" enclosures.

Primary Electric Underground Enclosures

4' 6" x 8' 6" (#7) Enclosure and Extensions

Notes

1. Do not break out sump.
2. Joints must be interchangeable with those shown in Detail B and approved by PG&E electric distribution personnel.

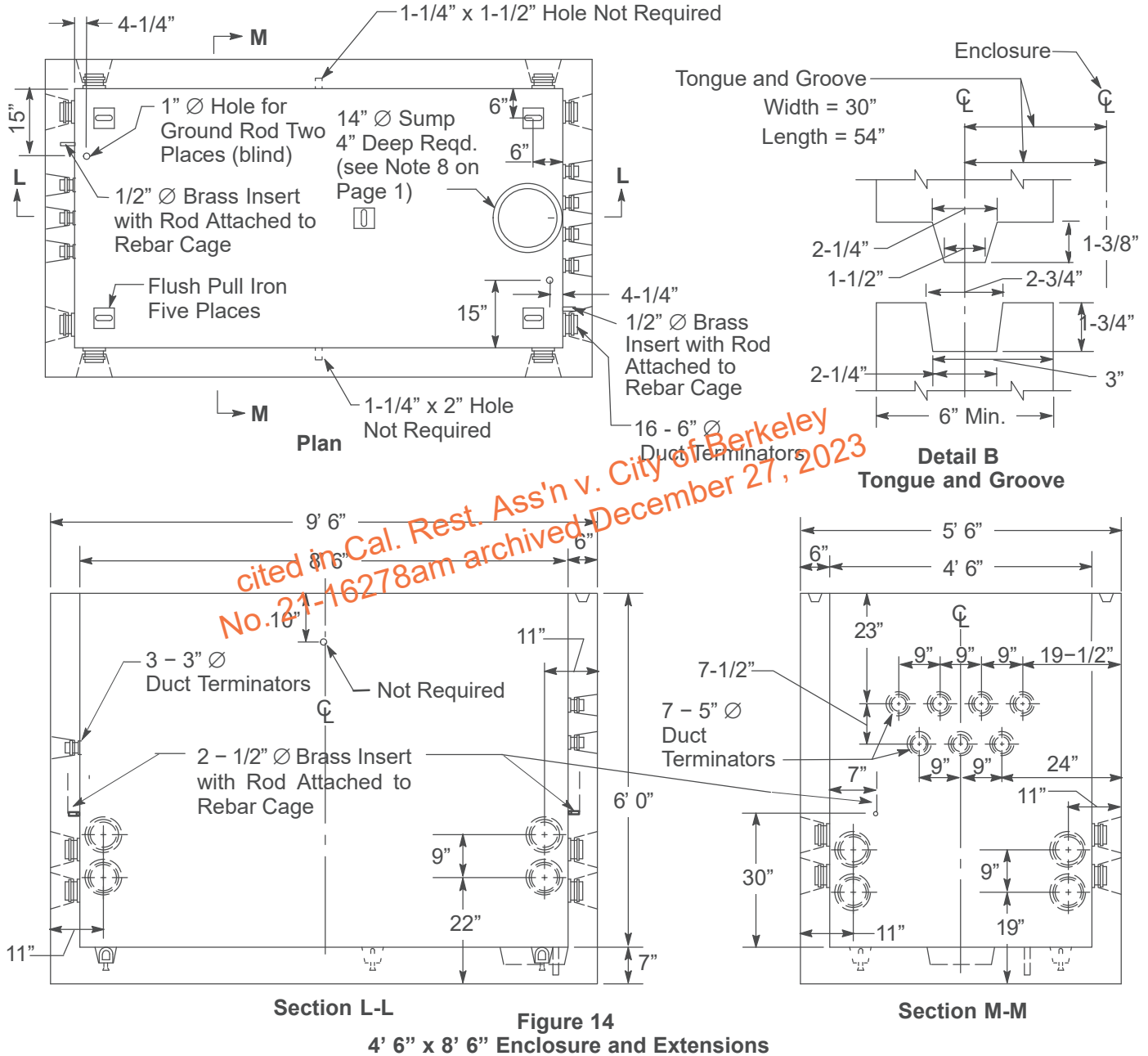


Table 12 Parts for Enclosure and Extensions (Figure 14)

Item	Description	Code	Weight - Approximate (lbs.)
1	Body, 72" Depth	043376	17,520
2	Extension, 6" Depth	041094	1,070
3	Extension, 12" Depth	043415	2,140
4	Extension, 18" Depth	043377	3,210

### Primary Electric Underground Enclosures

#### 4' 6" x 8' 6" (#7) Aluminum Quick-Release Cover Assembly - Incidental Traffic

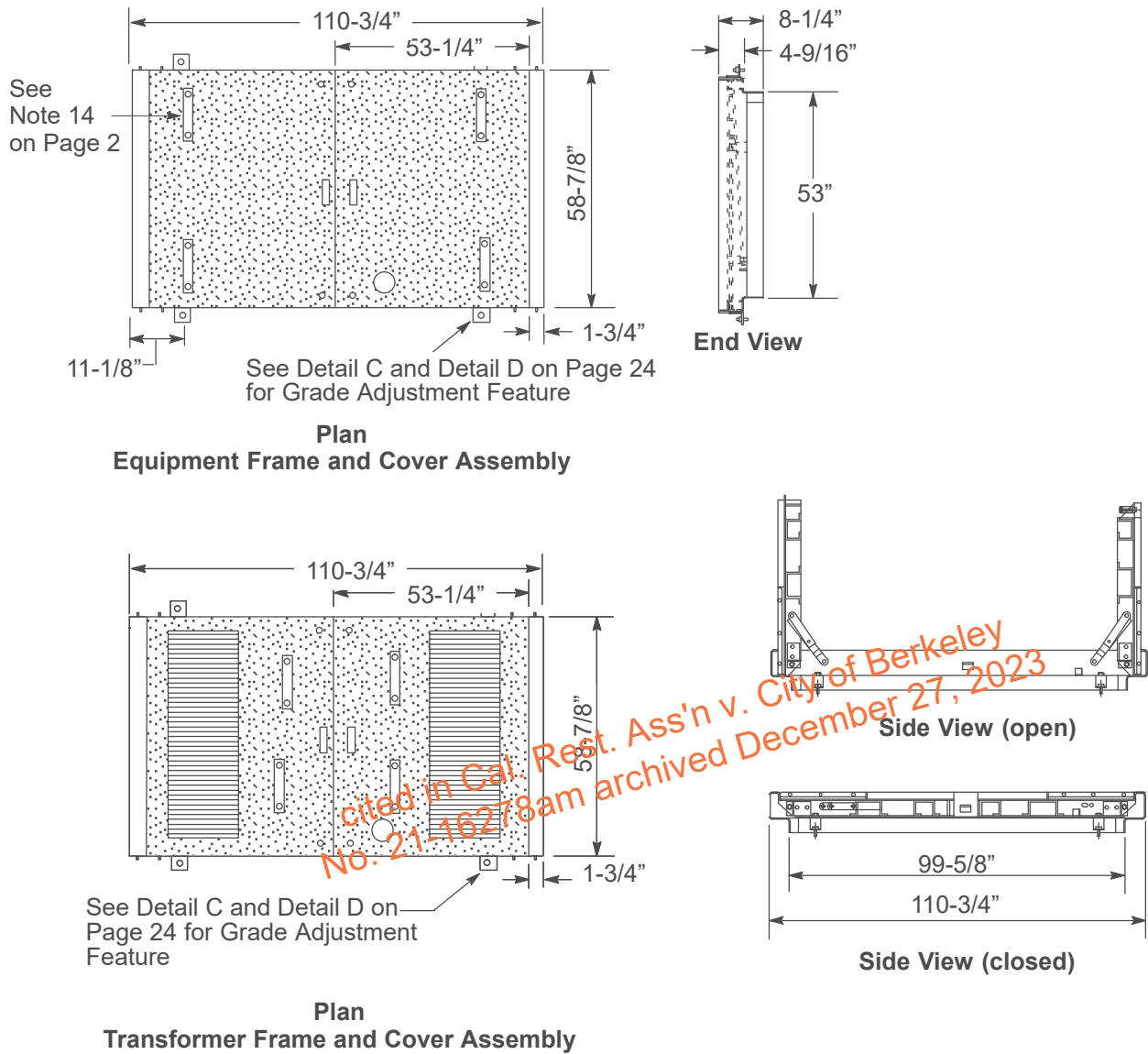


Figure 15  
4' 6" x 8' 6" Quick-Release Cover Assembly - Incidental Traffic

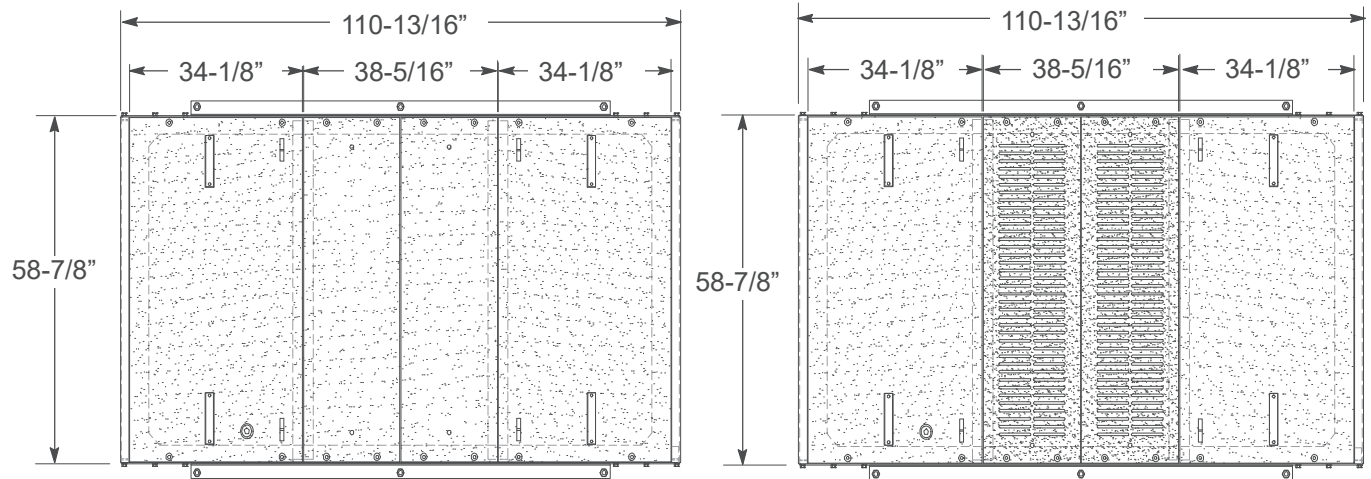
Table 13 Complete Frame and Cover Assembly

Type of Enclosure	Type of Traffic	Type of cover	Code
Transformer	Incidental	Quick-Release Aluminum	031830
	Full-Traffic <sup>1</sup>	Quick-Release Steel	041055
	Heavy Full-Traffic	Concrete	041442
Equipment	Incidental	Quick-Release Aluminum	040642
	Full-Traffic <sup>1</sup>	Quick-Release Steel	041054
	Heavy Full-Traffic	Concrete	041443

<sup>1</sup> For application guide, see Note 23 on Page 3.

### Primary Electric Underground Enclosures

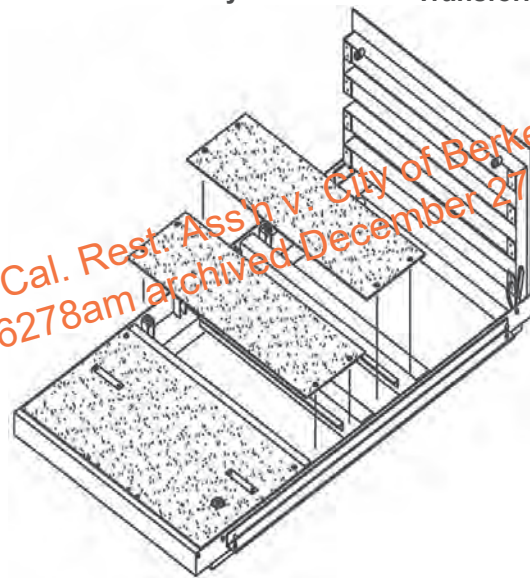
#### 4' 6" x 8' 6" (#7) Steel Quick-Release Cover Assembly- Full Traffic



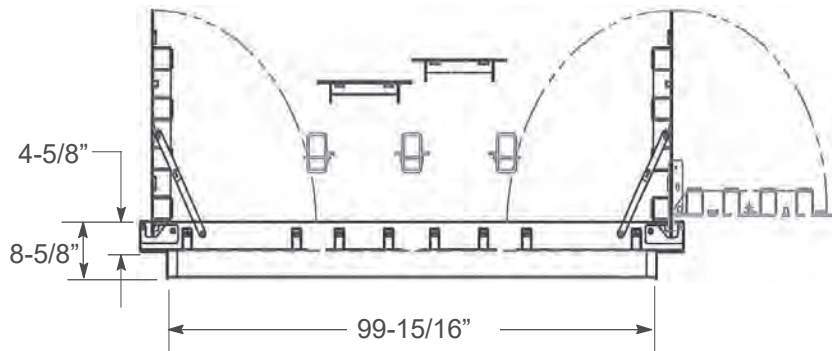
Plan  
Equipment Frame and Cover Assembly

Plan  
Transformer Frame and Cover Assembly

*cited in Cal. Rest. Ass'n v. City of Berkeley  
No. 21-16278am archived December 27, 2023*



Isometric View



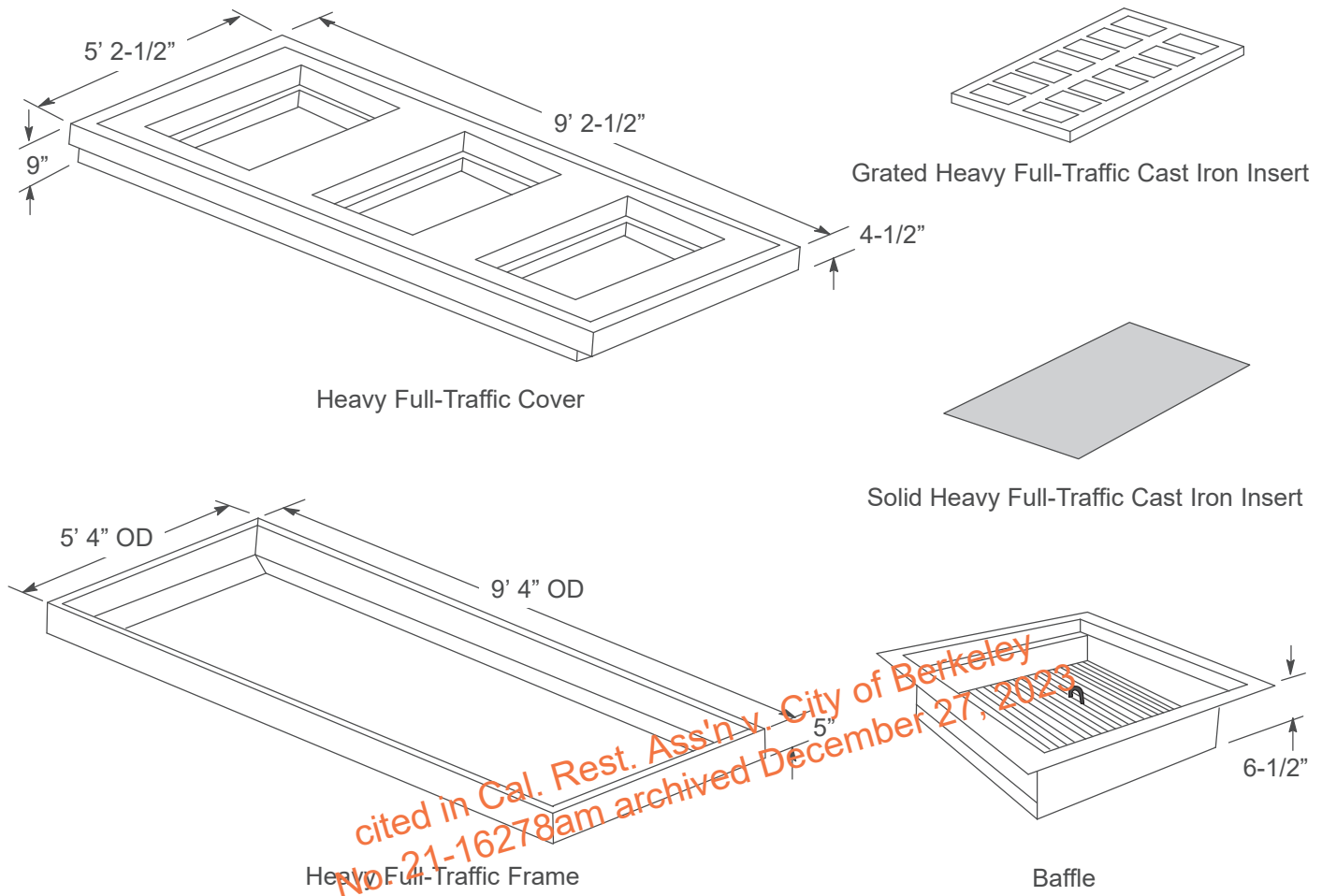
Side View

Figure 16

4' 6" x 8' 6" Steel Quick-Release Cover Assembly - Full Traffic

### Primary Electric Underground Enclosures

#### 4' 6" x 8' 6" (#7) Heavy Full-Traffic Cover Assemblies



*cited in Cal. Rest. Ass'n v. City of Berkeley  
No. 21-16278am archived December 27, 2023*

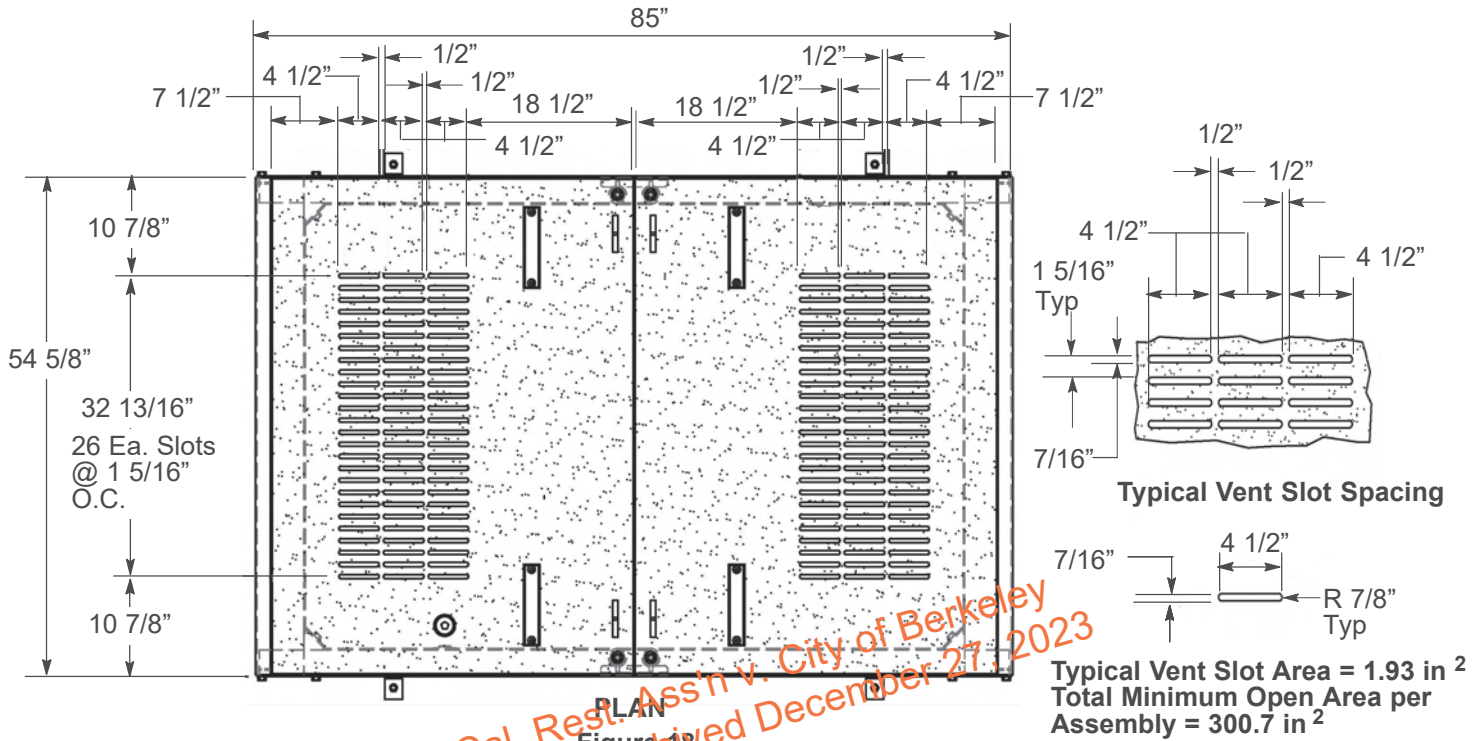
**Figure 17**  
**4' 6" x 8' 6" Heavy Full-Traffic Cover Assembly**

**Table 14 Component Parts**

Description	Weight	Code
4' 6" x 8' 6", HFVT Concrete Cover Without Inserts	3,840 lbs.	040340
4' 6" x 8' 6", HFVT 5' x 5' x 1/2" Steel Frame With Adjustment Feature	450 lbs.	040341
Cast Iron Grate Inserts for Transformer Enclosures	120 lbs.	040346
Cast Iron Solid Inserts for Splice Equipment Enclosures	180 lbs.	040343
Baffle	25 lbs.	360036

Primary Electric Underground Enclosures

Transformer Laser Cut Cover Assembly (Incidental Traffic Shown)



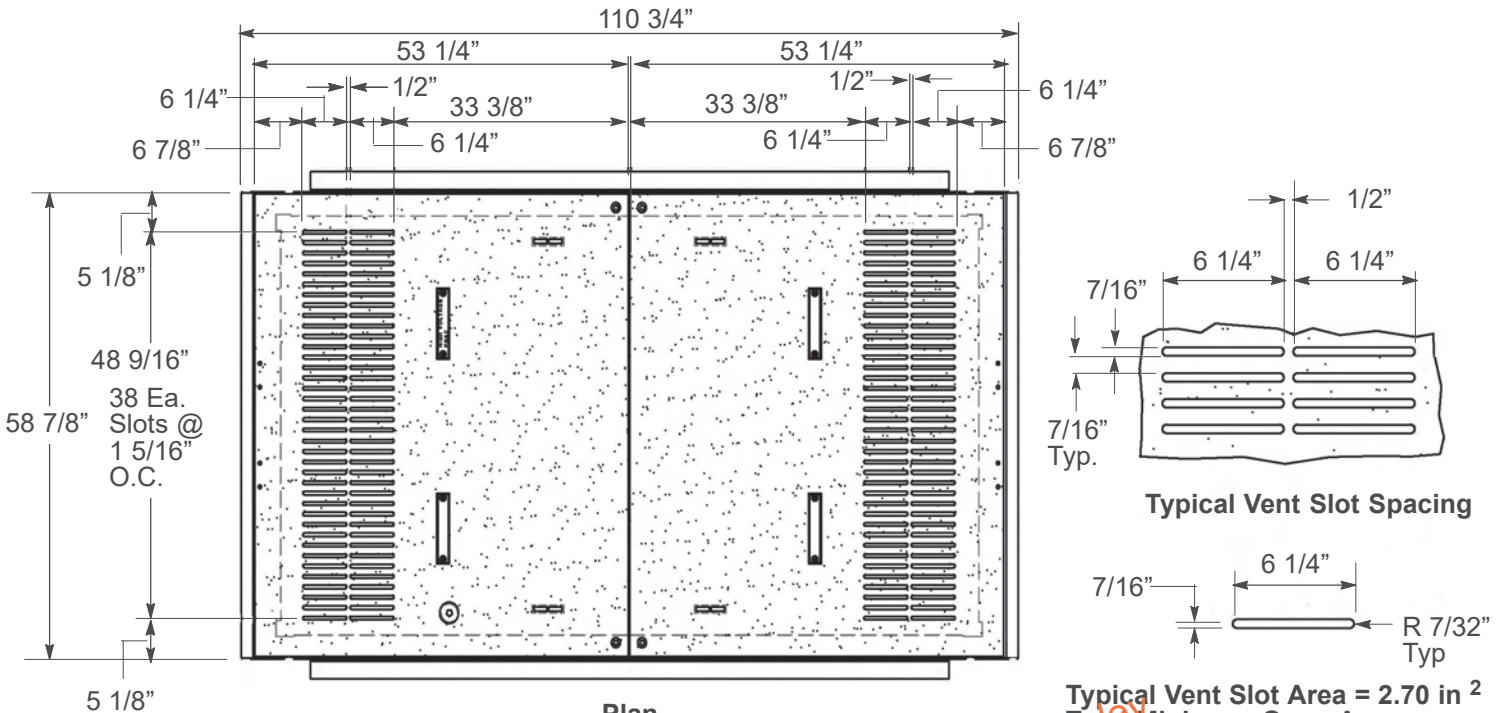
PLAN  
Figure 18  
4' 0" x 6' 6" (#6) Transformer Assembly - Vent Slot Detail  
cited in Cal. Rest. Ass'n v. City of Berkeley  
No. 21-16278am Archived December 27, 2023

Note:

Although the 4' 0" x 6' 6" (#6) cover has slightly different dimensions than the cover shown on Figure 9 on Page 14, this cover fits on the #6 body enclosure just as well as the cover shown on Figure 9 on Page 14.

### Primary Electric Underground Enclosures

#### Transformer Laser Cut Cover Assembly (continued)

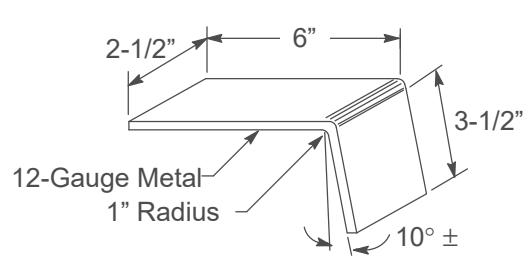
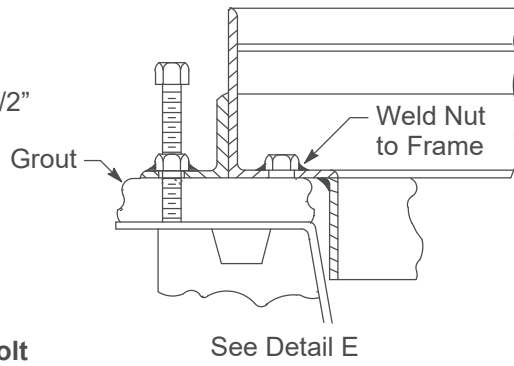
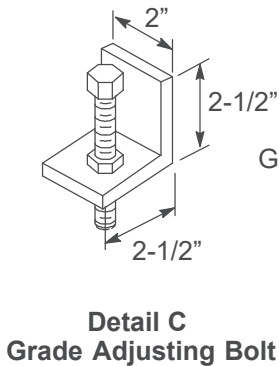


Plan  
**Figure 19**  
 4' 6" x 8' 6" (#7) Transformer Assembly – Vent Slot Detail

#### Notes

1. Laser cut transformer quick-release cover assembly is an approved design for incidental and full-traffic cover assemblies.
2. Material codes for ordering laser cut cover assemblies are the same as the fiberglass grate insert cover assemblies. Therefore, either type of transformer quick-release cover assembly will be shipped.
3. Design complies with the Americans with Disabilities Act (ADA) Section 30.2.

#### Details for Frame Assemblies

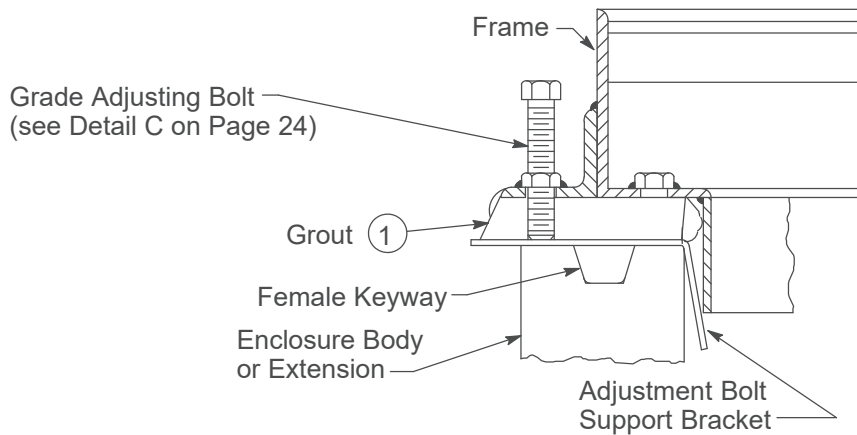


See Detail E  
**Detail D**  
 Grade Adjusting Feature

**Detail E**  
 Adjustment Bolt Support Bracket  
 Use M041601 Code to Order

## Primary Electric Underground Enclosures

## Cement Grouting Instructions for All Enclosure Frame



**Figure 20**  
**Grouting Incidental Enclosure Frame**

**Table 15 Grouting Material (structural - Figure 20)**

Item	Quantity	Description	Code
1 <sup>1</sup>	Sack - 55 lbs.	Grout, Zero Shrink, High-Early Strength	121016

<sup>1</sup> One sack of grout is required for approximately each 1/2" of space between the enclosure and the frame on a 4' 6" x 8' 6" enclosure.

### Instructions

1. Thoroughly clean all surfaces of the enclosure that the grout will contact. Use clean water to remove dust from surfaces.
2. Remove sufficient soil from around the enclosure to preclude accidentally mixing dirt with the grout. Install the enclosure frame and adjust it to grade.
3. Saturate all grout-contact surfaces of the enclosure with water for as long as possible before grouting using wet rags laid in and around the keyway. The recommended minimum saturation time is **24 hours**. Re-saturate the keyways with water before leaving the job. Remove excess water from the female keyway just prior to grouting.
4. Mix grout in a wheelbarrow with **clean** water. Do not mix more grout than can be easily used within 15 minutes. The consistency of the grout should allow it to flow under pressure.
5. Install the grout directly from a shovel onto the enclosure using hands with gloves. After an adequate amount of grout has been applied, use a trowel to apply additional pressure to the grout so that all voids are filled and the grout is completely consolidated. This is necessary to ensure a full bearing surface for the frame.
6. After wiping off any excess grout and making sure that all voids are filled with grout, cover the grout surface with water-saturated rags. While on the job, moisten the rags often. Re-saturate the rags with water before leaving the job. The water-saturated rags are required to cure the grout properly.
7. Keep wet rags on and traffic off the enclosure for **24 hours** to allow the grout to set up properly.
8. Do not backfill and tamp around the enclosure until the set-up period has concluded.
9. Remove the rags before backfilling around the enclosure.
10. Repair any damaged grout by repeating the above procedure.
11. Ready-mix concrete (5-sack mix) is an acceptable alternate.



**Primary Electric Underground Enclosures**



---

**Revision Notes**

Revision 25 has the following changes:

1. Update document owner's name on Page 1.
2. Clarify Note 5D on Page 1 that 1" minimum drain rock size and the intent for tamping and resurfacing.
3. Clarify Note 9 on Page 2 to specify secondary conduit cover requirements at enclosure entry.
4. Add Note 16 on Page 2 to state the alternative extension install with conventional building materials is not allowed.
5. Add Note 26 on Page 3 to specify horizontal separation requirements between enclosure and wet facility.
6. Add Note 27 on Page 3 to include drag-off cover replacement reference.
7. Typo correction of Table 1 that Single phase Horizontal Transformer Enclosure depth is 5'.
8. Delete duplicate row of "200 Amp Automatic Interrupter" of Table 1 on Page 5.
9. Clarify on Table 1 Note 1 on Page 5 that existing enclosure depth of 36 inches minimum.
10. Typo correction of Table 2 that code 040334 is with "Quick-Release Aluminum" cover.
11. Fix Figure 2 Section A-A dimension callout.
12. Clarify the short wall thickness on Figure 8 Plan.
13. Correct Figure 8 Section D-D base dimension callout.
14. Clarify Note 1 on Page 18 to specify the swedge reducers are only for primary conduits less than 6 inches.
15. Typo correction of Note 3 on Page 24.
16. Correct Figure 14 Plan and Section M-M dimension callouts.

*cited in Cal. Rest. Ass'n v. City of Berkeley  
No. 21-16278am archived December 27, 2023*

		<b>APPLICATION OF UNDERGROUND DISTRIBUTION TRANSFORMERS</b>		<b>062111</b>
<b>Asset Type:</b>	Electric Distribution	<b>Function:</b>	Construction	
<b>Issued by:</b>	Michael Thibault (MLTC) 	<b>Date:</b>	03-25-22	
<b>Rev. #27:</b> This document replaces PG&E Document 062111, Rev. #26. For a description of the changes, see Page 26.				

**Purpose and Scope**

This document provides a convenient reference for the types of transformers that are purchasable and used for underground distribution. The available voltages and kVA ratings are indicated along with the applicable codes to facilitate ordering.

**General Information**

1. To conserve space and avoid overlap with other documents, the description of transformers shown has been shortened. Individual characteristics of these transformers such as dimensions, accessories, and protection can be determined by making reference to the application documents.
2. Application
  - A. Single-Phase: The standard transformer for single-phase service is the Style DF-LB, single-phase, pad-mounted transformer (see Table 1 through Table 3 on Page 5). The 25 kVA through 100 kVA sizes are used for new construction. The 167 kVA size is reserved for replacement use, to solve loading or voltage problems. Where their use is required, several other types may be available with the required voltage and kVA ratings.
    - (1) Chester area pad-mount transformer (see Table 4 on Page 5).
    - (2) Subsurface horizontal transformer (see Table 5 and Table 6 on Page 6).
    - (3) Subway-LB transformer (see Table 8 on Page 7).
  - B. Three-Phase: The standard transformer for three-phase service is Style MTP, Style IIE-LB, or Style IIG pad-mount transformer (see Table 12 through Table 19 on Pages 8 through 10). Where their use is required, several other types may be available with the required voltage and kVA ratings.
    - (1) Duplex-LB pad-mount transformer (see Table 9 on Page 7).
    - (2) Duplex subsurface transformers (see Table 21 on Page 10).
    - (3) Radial dead-front transformer (see Table 18 on Page 10).
    - (4) Style IIC transformer (see Table 20 on Page 10).
    - (5) Style IIH transformer (see Table 41 on Page 16).
    - (6) UCD-LB transformer (see Table 22 on Page 11).
  - C. "-LB" designation means that the transformer has the following characteristics:
    - (1) Uses bayonet fuses.
    - (2) Has backup current-limiting (CL) fuses.
    - (3) Has a load-break switch between bayonet and CL fuses.
    - (4) Will accommodate load-break elbows.
3. For replacement options of older style transformers, see [Document 068195](#) for recommendations.
4. See [Document 072149](#) for when to use pad-mount, subsurface, or vault-type transformers.
5. Each transformer code has been assigned a footnote indicating the desired use of the transformer as defined below:
  - A. "1 – Current Standard Design and May Be Purchased" - these are transformers with the most current type, size, and voltage rating and are regularly purchased and used.
  - B. "4 – Use for Replacement Only and May Be Purchased" - may be purchased as required for replacements. They should not be used for new construction.

**Application of Underground Distribution Transformers**

---

- C. Transformers coded with an "E" are included in emergency stock.
  - D. Transformers coded as 1 are available for use on new business jobs.
  - E. Transformers coded as 4 are to be used only when required to replace an existing installation.
6. Transformers indicated as "stainless steel" have all exterior metal parts (unless otherwise noted in the referenced documents) fabricated out of stainless steel or other material of equal or superior corrosion resistance. These units shall be used whenever a transformer is to be installed in the severe or moderate corrosion areas of [Document 032911](#). Stainless steel units should also be used whenever local experience has determined that transformers experience accelerated corrosion leading to early replacement.

*cited in Cal. Rest. Ass'n v. City of Berkeley  
No. 21-16278am archived December 27, 2023*

**Application of Underground Distribution Transformers****Table of Contents**

	Table/Figure	Page No.
<b>Types Suitable for New Construction</b>		
Single-Phase:		
• Pad-Mount Style DF-LB	Table 1 – Table 3	
• Pad-Mount Chester Area	Table 4	5
• Subsurface, Horizontal	Table 5 – Table 6	6
• Subsurface, Round	Table 7	6
• Subsurface, Subway-LB	Table 8	7
Three-Phase, Pad-Mount:		
• Duplex-DF	Table 9	7
• Style MTP	Table 10 – Table 11	7
• Style IIE-LB	Table 12 – Table 17	8–9
• Radial Dead-Front	Table 18	10
• Style IIG	Table 19	10
• Style IIC	Table 20	10
Three-Phase, Subsurface:		
• Duplex	Table 21	10
• UCD-LB	Table 22	11
<b>Specialty Transformers</b>		
Three-Phase, Subsurface :		
• Network	Table 23 – Table 25	11
Three-Phase, Dry Type:		
• Network	Table 26 – Table 27	12
Three-Phase, Pad-Mount:		
• Network	Table 28	12
• System Tie	Table 29 – Table 30	12
• Grounding Bank	Table 31	13
• Zigzag-Radial Dead-Front	Table 32	13
<b>Types for Replacements Only</b>		
Single-Phase:		
• Pad-Mount Live-Front, Clam Shell	Table 33 – Table 34	13–14
• Subsurface, Round	Table 35 – Table 37	14–15
Three-Phase, Pad-Mount:		
• Style IIC	Table 38	15
• Style IIF	Table 39 – Table 40	15–16
• Style IIH	Table 41	16
• Radial, Dead-Front	Table 42	16
• Radial, Live-Front	Table 43 – Table 44	17
Three-Phase, Subsurface Vault	Table 45	17
<b>Transformer Winding Designations</b>	Table 47 – Table 48	18–19
<b>Transformer Insulating Fluid</b>	Table 49	19
<b>System Primary Voltages</b>	Table 50	20
<b>Pictorial Index</b>	Figure 1 – Figure 6	21–26

### Application of Underground Distribution Transformers

References	Location	Document
<a href="#">Cabinet and Transformer for Single-Phase 12 kV Pad-Mounted Transformer Installation</a>		
<a href="#">Underground Residential Areas</a>	ELS	032732
<a href="#">Corrosion Area-Overhead Lines</a>	OH: General/EPM	032911
<a href="#">Requirements for Conventional Three-Phase Small Power Transformers</a>	ELS	033705
<a href="#">Single-Phase, Subsurface, Round Transformers</a>	UG-1: Transformers	035313
<a href="#">Underground Commercial Distribution, Three-Phase, Subsurface Transformer</a>	UG-1: Transformers	039830
<a href="#">Live-Front, Low-Profile, Single-Phase, Pad-Mounted Transformers</a>	UG-1: Transformers	042761
<a href="#">Cabinet and Transformer for Low-Profile, Single-Phase, 6.9 kV Pad-Mounted Transformer Installation</a>		
<a href="#">Underground Residential Systems</a>	ELS	042764
<a href="#">Radial, Three-Phase, Pad-Mounted Transformers</a>	UG-1: Transformers	043816
<a href="#">Loop-Style, Three-Phase, Pad-Mounted Transformers</a>	UG-1: Transformers	045290
<a href="#">Pad-Mounted Network Transformer</a>	UG-2: Transformers	045774
<a href="#">Open Wye to Zigzag Wye Transformation Equipment and Connection</a>	UG-1: Transformers	045786
<a href="#">Three-Phase, Pad-Mounted Autotransformer</a>	UG-1: Transformers/EPM	051119
<a href="#">Duplex-Type, Three-Phase, Subsurface Transformer</a>	UG-1: Transformers	051776
<a href="#">Horizontal, Single-Phase, Subsurface Transformers</a>	UG-1: Transformers	060578
<a href="#">Pad-Mounted Ground Fault Sensing for Cogeneration</a>	UG-1: General	062264
<a href="#">Single-Phase, Dead-Front, and Duplex, Pad-Mounted Transformer</a>	UG-1: Transformers	064307
<a href="#">4 kV Circuit Supply</a>	UG-1: Transformers	068184
<a href="#">Distribution Transformer Replacement Options</a>	UG-1: Transformers/EDM	068195
<a href="#">Three-Phase Subsurface Network Transformers</a>	UG-2: Transformers	072137
<a href="#">Three-Phase Subsurface Vault Transformers</a>	UG-2: Transformers	072138
<a href="#">Single-Phase Subway Transformers</a>	UG-2: Transformers	072139
<a href="#">Pad-Mount Transformers-Style IIG and Style IIH</a>	UG-1: Transformers	072146
<a href="#">Selection of the Type of Underground Equipment</a>	UG-1: Transformers/Greenbook	072149
<a href="#">Engineering Material Specification #86, "Single-Phase, and Three-Phase Pad-Mounted Distribution Transformers"</a>	TIL	EMS 86
<a href="#">Engineering Material Specification 91, "Single-Phase and Three-Phase Subsurface Distribution Transformers"</a>	TIL	EMS 91

*cited in Cal. Rest. Ass'n v. City of Berkeley  
No. 21-16278am archived December 27, 2023*

## Application of Underground Distribution Transformers

**Single-Phase, Pad-Mount, for New Construction****Table 1 Codes for Style DF-LB, 1-Wire (2-Bushing) No Loop Switches With Transformer Switch With 2 Primary Bushings and 3 Secondary Bushings Including the Insulated Neutral (reference [Document 064307](#) and [Spec. 86](#)) – Self-Protected**

kVA	20,780GRDY/12,000	
	240/120 V	
	Mild Steel	Stainless Steel
25	261501 <sup>1</sup>	262890 <sup>1</sup>
50	261502 <sup>1</sup>	262891 <sup>1</sup>
100	261503 <sup>1</sup>	262892 <sup>1</sup>
167	261504 <sup>4, E</sup>	262893 <sup>4, E</sup>

**Table 2 Codes for Style DF-LB, 2-Wire, (4-Bushing) No Loop Switches With Transformer Switch With 4 Primary Bushings and 3 Secondary Bushings Including the Insulated Neutral (reference [Document 064307](#) and [Spec. 86](#)) – Self-Protected**

kVA	12,000/20,780GrdY		17,200	20,780
	240/120 V		240/120 V	240/120 V
	Mild Steel	Stainless	Mild Steel	Mild Steel
25	261507 <sup>1</sup>	261519 <sup>1</sup>	261511 <sup>1</sup>	261515 <sup>1</sup>
50	261508 <sup>1</sup>	261520 <sup>1</sup>	261512 <sup>1</sup>	261516 <sup>1</sup>
100	261509 <sup>1</sup>	261521 <sup>1</sup>	261513 <sup>1</sup>	261517 <sup>1</sup>
167	261510 <sup>4</sup>	261522 <sup>4, E</sup>	261514 <sup>4, E</sup>	261518 <sup>4, E</sup>

**Table 3 Codes for Style DF-LB, 3-Wire (6-Bushing) No Loop Switches With Transformer Switch and With 6 Primary Bushings and 3 Secondary Bushings Including the Insulated Neutral (reference [Document 064307](#) and [Spec. 86](#)) – Self-Protected**

kVA	2,400/ 4,160GrdY	4,160 x 12,000		12,000/ 20,780GrdY		17,200	20,780			
	240/120 V	240/120 V		240/120 V		480/240 V	240/120 V	240/120 V		
	Mild Steel	Mild Steel	Stainless	Mild Steel	Stainless	Mild Steel	Mild Steel	Mild Steel	Stainless	
25	–	–	–	261531 <sup>1</sup>	261543 <sup>1</sup>	262721 <sup>1, E</sup>	261535 <sup>1</sup>	261539 <sup>1</sup>	262894 <sup>1</sup>	
50	–	–	–	261532 <sup>1</sup>	261544 <sup>1</sup>	–	261536 <sup>1</sup>	261540 <sup>1</sup>	262895 <sup>1</sup>	
100	262043 <sup>1, E</sup>	261785 <sup>1</sup>	261988 <sup>1, E</sup>	261533 <sup>1</sup>	261545 <sup>1</sup>	–	261537 <sup>1</sup>	261541 <sup>1</sup>	262896 <sup>1</sup>	
167	–	–	–	261534 <sup>4</sup>	261546 <sup>4, E</sup>	–	261538 <sup>4, E</sup>	261542 <sup>4, E</sup>	262897 <sup>4, E</sup>	

**Table 4 Codes for Chester Style Specialty Transformers - Single-Phase, Pad-Mount, Load-Break, Dead-Front With Single-Phase Cabinet for Use in the Chester, CA Area. With 2 Primary Bushings and 3 Secondary Bushings Including the Insulated Neutral (see ANSI/IEEE Type 2(a) per IEEE C57.12.25) – Self-Protected**

kVA	12,470GrdY/7,200 – 240/120 V	
	Mild Steel	
50	017414 <sup>1, E</sup>	
100	–	

<sup>1</sup> Current standard design and may be purchased.<sup>4</sup> Use for replacement only and may be purchased.<sup>E</sup> Included in Emergency Stock

## Application of Underground Distribution Transformers

**Single-Phase, Subsurface, for New Construction****Table 5 Codes for Subsurface Horizontal, Single-Phase With 4 Primary Bushings With 2 (25-50 kVA) or 4 (75-167 kVA) Hot Secondary Leads. Neutral Lead May Be Permanently Grounded. (reference Document 060578 and Spec. 91) – Self-Protected, Stainless Steel**

kVA	12,000/20,780GrdY 240/120 V		17,200 240/120 V	20,780 240/120 V	
	No Switch	With Single-Phase Switch	No Switch	No Switch	With Single-Phase Switch
25	262389 <sup>1</sup>	-	262395 <sup>1</sup>	262436 <sup>1</sup>	-
50	262391 <sup>1</sup>	-	262396 <sup>1</sup>	262437 <sup>1, E</sup>	-
100	262393 <sup>1, E</sup>	013884 <sup>1, E</sup>	262397 <sup>1</sup>	262438 <sup>1, E</sup>	262439 <sup>1, E</sup>
167	262394 <sup>4, E</sup>	262181 <sup>4, E</sup>	262398 <sup>4, E</sup>	263050 <sup>4 E</sup>	-

**Table 6 Codes for Subsurface Horizontal, Single-Phase With 6 Primary Bushings With 2 (25-50 kVA) or 4 (75-167 kVA) Hot Secondary Leads. Neutral Lead May Be Permanently Grounded. (reference Document 060578 and Spec. 91) – Self-Protected, Stainless Steel**

kVA	12,000/20,780GrdY 240/120 V		17,200 – 240/120 V		20,780 – 240/120 V	
	No Switch	With Three-Phase Switch	No Switch	With Three-Phase Switch	No Switch	With Three-Phase Switch
25	260328 <sup>1</sup>	027264 <sup>1, E</sup>	261106 <sup>1</sup>	-	261102 <sup>1</sup>	-
50	260668 <sup>1, E</sup>	027265 <sup>1, E</sup>	261107 <sup>1, E</sup>	-	261103 <sup>1, E</sup>	-
100	260882 <sup>1, E</sup>	027266 <sup>1, E</sup>	261108 <sup>1</sup>	027269 <sup>1, E</sup>	261104 <sup>1, E</sup>	027267 <sup>1, E</sup>
167	261000 <sup>4, E</sup>	-	261109 <sup>4, E</sup>	-	261105 <sup>4, E</sup>	-

**Table 7 Codes for Subsurface Round, Single-Phase With 3 Secondary Bushings, Neutral May be Permanently Grounded. Use to Supply Single-Phase Load. (reference Document 035313 and Spec. 91) – Self-Protected, Stainless Steel**

kVA	4160/7200Y 240/120 V 4 Primary Bushings	4,160GrdY/2,400 240/120 V 2 Primary Bushings	
	No Switch	No Switch	With Single-Phase Switch
100	262371 <sup>1, E</sup>	262120 <sup>1, E</sup>	262143 <sup>1, E</sup>

(See Table 36 on Page 14 for other single-phase round transformers.)

<sup>1</sup> Current standard design and may be purchased.<sup>4</sup> Use for replacement only and may be purchased.  
<sup>E</sup> Included in Emergency Stock

## Application of Underground Distribution Transformers

**Single-Phase, Subsurface, for New Construction (continued)****Table 8 Codes for Subsurface Subway-LB, Single-Phase, (reference [Document 072139](#) and [Spec. 91](#)) – Self-Protected, Stainless Steel**

kVA	2,400/4,160Y-120/240 3 Primary Bushings 4 Secondary Bushings	12,000/20,780Y – 120/240	
		2 Primary Bushings 4 Secondary Bushings	3 Primary Bushings 4 Secondary Bushings
50	261388 <sup>1, E</sup>	261384 <sup>1</sup>	261391 <sup>1</sup>
100	261389 <sup>1</sup>	261385 <sup>1, E</sup>	261392 <sup>1, E</sup>
167	261390 <sup>1, E</sup>	261386 <sup>1</sup>	261393 <sup>1</sup>
250	–	261387 <sup>1, E</sup>	261394 <sup>1, E</sup>

**Three-Phase, Pad-Mount, for New Construction****Table 9 Codes for Duplex-Style DF, Three-Phase, Pad-Mount, No Loop Switch, With Transformer Switch With 6 Primary Bushings and 4 Secondary Bushings Including the Insulated Neutral (reference [Document 064307](#) and [Spec. 86](#)) – Self-Protected**

kVA	12,000/20,780GrdY/12,000		17,200	20,780
	240/120 V		240/120 V	240/120 V
	Mild Steel	Stainless	Mild Steel	Mild Steel
25/10	261547 <sup>1</sup>	–	261551 <sup>1</sup>	–
50/10	261548 <sup>1, E</sup>	262047 <sup>1, E</sup>	261552 <sup>1, E</sup>	261914 <sup>1, E</sup>
100/25	261549 <sup>1</sup>	–	261553 <sup>1</sup>	–
100/50	261550 <sup>1, E</sup>	262049 <sup>1, E</sup>	261554 <sup>1, E</sup>	261915 <sup>1, E</sup>

**Table 10 Codes for Style MTP, Three-Phase, Pad-Mount With 6 Primary Bushings and 4 Secondary Bushings Including the Insulated Neutral (reference [Document 045290](#) and [Spec. 86](#)) – Self-Protected**

kVA	12,000/20,780GrdY/12,000				20,780	
	208Y/120 V		480Y/277 V		208Y/120 V	480Y/277 V
	Mild Steel	Stainless	Mild Steel	Stainless	Mild Steel	
45	261897 <sup>1</sup>	261909 <sup>1</sup>	261898 <sup>1</sup>	261910 <sup>1</sup>	261905 <sup>1</sup>	261906 <sup>1</sup>
150	261899 <sup>1</sup>	261911 <sup>1, E</sup>	261900 <sup>1</sup>	261912 <sup>1, E</sup>	261907 <sup>1, E</sup>	261908 <sup>1, E</sup>

**Table 11 Codes for Style MTP, Three-Phase, Pad-Mount With 6 Primary Bushings and 4 Secondary Bushings Including the Insulated Neutral (reference [Document 045290](#) and [Spec. 86](#)) – Self-Protected**

kVA	4,160		17,200	
	208Y/120 V		480Y/277 V	
	Mild Steel		Mild Steel	
45	–	–	261901 <sup>1</sup>	261902 <sup>1</sup>
150	262782 <sup>1, E</sup>	262783 <sup>1, E</sup>	261903 <sup>1, E</sup>	261904 <sup>1, E</sup>

<sup>1</sup> Current standard design and may be purchased.<sup>4</sup> Use for replacement only and may be purchased.  
<sup>E</sup> Included in Emergency Stock



## Application of Underground Distribution Transformers

**Three-Phase, Pad-Mount, for New Construction (continued)****Table 12 Codes for Style IIE-LB, No Loop Switches, With Transformer Switch With 6 Primary Bushings and 4 Secondary Bushings Including the Insulated Neutral (reference [Document 045290](#) and [Spec. 86](#)) – Self-Protected**

kVA	4,160 x 12,000	
	208Y/120 V	
	Mild Steel	
75	261397 <sup>1</sup>	261401 <sup>1</sup>
150	261398 <sup>1</sup>	261402 <sup>1</sup>
300	261399 <sup>1, E</sup>	261403 <sup>1, E</sup>
750	261400 <sup>1, E</sup>	261404 <sup>1, E</sup>

**Table 13 Codes for Style IIE-LB, No Loop Switches, With Transformer Switch With 6 Primary Bushings and 4 Secondary Bushings Including the Insulated Neutral (reference [Document 045290](#) and [Spec. 86](#)) (continued) – Self-Protected**

kVA	12,000/20,780GrdY/12,000						12,000/20,780Y12,000	
	208Y/120 V		480Y/277 V		2,400/4,160Y/2,400 V		240/120 Delta	
	Mild Steel	Stainless	Mild Steel	Stainless	Mild Steel	Stainless	Mild Steel	Stainless
75	261405 <sup>1</sup>	261443 <sup>1</sup>	261410 <sup>1</sup>	261446 <sup>1</sup>	-	-	-	-
150	261406 <sup>1</sup>	263128 <sup>1</sup>	261411 <sup>1</sup>	263124 <sup>1</sup>	-	-	261421 <sup>1</sup>	-
300	261407 <sup>1, E</sup>	261444 <sup>1, E</sup>	261412 <sup>1, E</sup>	261447 <sup>1, E</sup>	-	-	261422 <sup>1</sup>	262645 <sup>1, E</sup>
750	261408 <sup>1</sup>	263125 <sup>1</sup>	261413 <sup>1</sup>	263127 <sup>1</sup>	261417 <sup>1</sup>	-	-	-
1,000	261409 <sup>1, E</sup>	261445 <sup>1, E</sup>	261414 <sup>1, E</sup>	263448 <sup>1, E</sup>	261418 <sup>1</sup>	261450 <sup>1</sup>	-	-
1,500	-	-	261415 <sup>1</sup>	261619 <sup>1</sup>	261419 <sup>1</sup>	-	-	-
2,500	-	-	261416 <sup>1</sup>	261449 <sup>1, E</sup>	261420 <sup>1</sup>	261451 <sup>1, E</sup>	-	-

**Table 14 Codes for Style IIE-LB, No Loop Switches, With Transformer Switch With 6 Primary Bushings and 4 Secondary Bushings Including the Insulated Neutral (reference [Document 045290](#) and [Spec. 86](#)) (continued) – Self-Protected**

kVA	17,200		
	208Y/120 V		2,400/4,160Y/2,400 V
	Mild Steel		Mild Steel
75	261423 <sup>1</sup>		261428 <sup>1</sup>
150	261424 <sup>1, E</sup>		261429 <sup>1, E</sup>
300	261425 <sup>1</sup>		-
750	261426 <sup>1, E</sup>		261431 <sup>1, E</sup>
1,000	261427 <sup>1, E</sup>		261432 <sup>1</sup>
1,500	-		261433 <sup>1, E</sup>
2,500	-		261434 <sup>1, E</sup>

<sup>1</sup> Current standard design and may be purchased.<sup>4</sup> Use for replacement only and may be purchased.<sup>E</sup> Included in Emergency Stock

## Application of Underground Distribution Transformers

**Three-Phase, Pad-Mount, for New Construction (continued)****Table 15 Codes for Style IIE-LB, No Loop Switches, With Transformer Switch With 6 Primary Bushings and 4 Secondary Bushings Including the Insulated Neutral (reference [Document 045290](#) and [Spec. 86](#)) (continued) – Self-Protected**

kVA	20,780			
	208Y/120 V		480Y/277 V	
	Mild Steel	Stainless	Mild Steel	Stainless
75	261437 <sup>1</sup>	261452 <sup>1</sup>	261440 <sup>1</sup>	261454 <sup>1</sup>
150	261438 <sup>1</sup>	–	261441 <sup>1</sup>	–
300	261439 <sup>1</sup>	261453 <sup>1, E</sup>	261442 <sup>1</sup>	261455 <sup>1, E</sup>

**Table 16 Codes for Style IIE-LB, With Three-Phase Loop Switches, With Transformer Switch With 6 Primary Bushings and 4 Secondary Bushings Including the Insulated Neutral (reference [Document 045290](#) and [Spec. 86](#)) – Self-Protected**

kVA	12,000/20,780GrdY/12,000			
	208Y/120 V		480Y/277 V	
	Mild Steel	Stainless	Mild Steel	Stainless
75	261456 <sup>1</sup>	–	261459 <sup>1</sup>	–
300	261457 <sup>1, E</sup>	–	261460 <sup>1, E</sup>	–
1,000	261458 <sup>1</sup>	261472 <sup>1, E</sup>	261461 <sup>1</sup>	261473 <sup>1, E</sup>
1,500	–	–	261893 <sup>1</sup>	–
2,500	–	–	261894 <sup>1</sup>	261895 <sup>1, E</sup>

**Table 17 Codes for Style IIE-LB, With Three-Phase Loop Switches, With Transformer Switch With 6 Primary Bushings and 4 Secondary Bushings Including the Insulated Neutral (reference [Document 045290](#) and [Spec. 86](#)) (continued) – Self-Protected**

kVA	17,200		20,780	
	208Y/120 V	480Y/277 V	208Y/120 V	480Y/277 V
	Mild Steel	Mild Steel	Mild Steel	Mild Steel
75	261462 <sup>1</sup>	261465 <sup>1</sup>	261468 <sup>1</sup>	261470 <sup>1</sup>
300	261463 <sup>1, E</sup>	261466 <sup>1, E</sup>	261469 <sup>1, E</sup>	261471 <sup>1, E</sup>
1,000	261464 <sup>1, E</sup>	261467 <sup>1, E</sup>	–	–
2,500	–	261896 <sup>1, E</sup>	–	–

<sup>1</sup> Current standard design and may be purchased.<sup>4</sup> Use for replacement only and may be purchased.<sup>E</sup> Included in Emergency Stock

## Application of Underground Distribution Transformers

**Three-Phase, Pad-Mount, for New Construction (continued)****Table 18 Codes for Radial Dead-Front, Three-Phase, Pad-Mount With 3 Primary Bushings and 4 Secondary Bushings Including the Insulated Neutral (reference [Document 043816](#) and [Spec. 86](#)) – Conventional**

kVA	20,780			
	208Y/120 V		480Y/277 V	
	Mild Steel	Stainless	Mild Steel	Stainless
750	-	-	263031 <sup>1, E</sup>	-
1,000	263029 <sup>1</sup>	261523 <sup>1, E</sup>	-	261524 <sup>1</sup>
1,500	-	-	263033 <sup>1</sup>	-
2,500	-	-	263035 <sup>1</sup>	261525 <sup>1, E</sup>

(See Table 42 on Page 16 for other three-phase radial DF.)

**Table 19 Codes for Style IIG, Three-Phase, Pad-Mount With Vacuum Fault Interrupter, With 6 Primary Bushings, 4 Secondary Bushings Including Insulated Neutral With Stainless Steel Cabinet and FR3 Insulating Fluid (reference [Document 072146](#) and [Spec. 86](#))**

kVA	12,000/20,780Grd/12,000		12,000/20,780Grd/12,000		17,200		20,780
	480Y/277		2,400/4160Y/2,400		480Y/277	2,400/4160Y/ 2,400	480Y/277
	No Loop Switch	With 2 Loop Switches	No Switch		No Loop Switch		
2955/3325	262702 <sup>1, E</sup>	262703 <sup>1, E</sup>	262704 <sup>1, E</sup>		262705 <sup>1, E</sup>	262706 <sup>1, E</sup>	262707 <sup>1, E</sup>

**Table 20 Codes for Style IIC, Three-Phase, Pad-Mount With 3 Primary Bushings and 4 Secondary Bushings Including the Insulated Neutral (reference [Document 045290](#) and [Spec. 86](#)) – Self-Protected**

kVA	4,160 x 12,000	
	208Y/120 V	
	Mild Steel	
1,500	-	
2,500	-	
	480Y/277 V	
	Mild Steel	
	260789 <sup>1</sup>	
	260791 <sup>1, E</sup>	

(See Table 38 on Page 15 for other Style IIC.)

**Three-Phase, Subsurface, for New Construction****Table 21 Codes for Subsurface Duplex, Three-Phase With 6 Primary Bushings and 3 Hot Secondary Leads or Insulated Spades. The Neutral is a Welded Spade. (reference [Document 051776](#) and [Spec. 91](#)) – Self-Protected, Stainless Steel**

kVA	12,000/20,780GrdY/12,000 – 240/120 V		17,200 – 240/120 V	
	No Switch	With Three-Phase Switch	No Switch	With Three-Phase Switch
25/10	262122 <sup>1</sup>	262131 <sup>1</sup>	262349 <sup>1</sup>	262348 <sup>1</sup>
50/10	262128 <sup>1, E</sup>	262132 <sup>1, E</sup>	262350 <sup>1, E</sup>	262354 <sup>1</sup>
75/15	-	262133 <sup>1</sup>	-	262355 <sup>1</sup>
100/25	262130 <sup>1</sup>	262134 <sup>1</sup>	262352 <sup>1</sup>	262356 <sup>1, E</sup>
100/50	262363 <sup>1, E</sup>	262318 <sup>1, E</sup>	262353 <sup>1, E</sup>	262357 <sup>1, E</sup>

<sup>1</sup> Current standard design and may be purchased.<sup>4</sup> Use for replacement only and may be purchased.<sup>E</sup> Included in Emergency Stock

## Application of Underground Distribution Transformers

**Three-Phase, Subsurface, for New Construction (continued)****Table 22 Codes for Subsurface UCD-LB, Three-Phase With Two, Three-Phase Loop Switches and With Transformer Switches With 6 Primary Bushings and 3 Hot Secondary Bushings. The Neutral May Be Permanently Grounded. (reference [Document 039830](#) and [Spec. 91](#)) – Self-Protected, Stainless Steel**

kVA	4,160 x 12,000		12,000/20,780GrdY/12,000		17,200	
	208Y/120 V	480Y/277	208Y/120	480Y/277	208Y/120	480Y/277
150	261798 <sup>1</sup>	261800 <sup>1</sup>	261802 <sup>1</sup>	261806 <sup>1</sup>	261810 <sup>1</sup>	261813 <sup>1</sup>
300	261799 <sup>1, E</sup>	261801 <sup>1, E</sup>	261803 <sup>1, E</sup>	261807 <sup>1, E</sup>	261811 <sup>1</sup>	261814 <sup>1</sup>
750	262327 <sup>1, E</sup>	262332 <sup>1, E</sup>	261804 <sup>1</sup>	261808 <sup>1</sup>	261812 <sup>1, E</sup>	261815 <sup>1, E</sup>
1,000	–	–	261805 <sup>1, E</sup>	261809 <sup>1, E</sup>	–	–

**Specialty Transformers****Table 23 Codes for Subsurface Network, Three-Phase With 3 Primary Bushings and 3 Secondary Bushings With No Ground Switch, No Termination Chamber (reference [Document 072137](#) and [Spec. 91](#)) – Conventional, Plate Steel**

kVA	12,000 – 208Y/120 V	12,000 – 480Y/277 V	12,000X34,500GrdY/19920 480Y/277 V	34,500GrdY/19,920 480Y/277 V
300	262664 <sup>1</sup>	–	–	–
500	262665 <sup>1</sup>	–	–	–
750	262666 <sup>1</sup>	262667 <sup>1, T</sup>	262673 <sup>1</sup>	262671 <sup>1</sup>
1,000	–	262668 <sup>1, T</sup>	262674 <sup>1</sup>	262662 <sup>1</sup>
1,500	–	262669 <sup>1, T</sup>	262675 <sup>1</sup>	262672 <sup>1</sup>
2,000	–	262670 <sup>1, T</sup>	262676 <sup>1</sup>	262663 <sup>1</sup>

**Table 24 Codes for Subsurface Network, Three-Phase With 3 Primary Bushings and 3 Secondary Bushings With Ground Switch and Termination Chamber (reference [Document 072137](#) and [Spec. 91](#)) – Conventional, Plate Steel**

kVA	12,000 – 208Y/120 V	12,000 – 480Y/277 V	12,000X34,500GrdY/19920 480Y/277 V	34,500GrdY/19,920 480Y/277 V
300	262407 <sup>4</sup>	–	–	–
500	262408 <sup>4</sup>	262410 <sup>4, T</sup>	–	–
750	262409 <sup>4, E</sup>	262411 <sup>4, T</sup>	262419 <sup>4</sup>	262415 <sup>4</sup>
1,000	–	262412 <sup>4, E, T</sup>	262420 <sup>4</sup>	262416 <sup>4</sup>
1,500	–	262413 <sup>4, T</sup>	262421 <sup>4</sup>	262417 <sup>4</sup>
2,000	–	262414 <sup>4, T</sup>	262422 <sup>4, E</sup>	262418 <sup>4</sup>

**Table 25 Codes for Subsurface Vault, Three-Phase with 3 Primary Bushings and 3 Secondary 600A ESNA Bushings ([Spec. 91](#)).**

kVA	12,000 x 34,500GrdY/19,920 – 4,160Y/2400 V
2,000	262889 <sup>1</sup>

<sup>1</sup> Current standard design and may be purchased.<sup>4</sup> Use for replacement only and may be purchased.

E Included in Emergency Stock

T With high voltage taps.

## Application of Underground Distribution Transformers

**Specialty Transformers (continued)****Table 26 Codes for Dry-Type Network. Three-Phase With 3 Primary Bushings and 3 Secondary Bushings – Conventional, 65/115° Rise Cast Coil, Rotated Layout**

kVA	12,000 – 208Y/120 V	12,000 – 480Y/277 V	34,500GrdY/19,920 480Y/277 V
500	262777 <sup>1, T</sup>	–	–
750	262778 <sup>1, T</sup>	262773 <sup>1, T</sup>	262779 <sup>1, T</sup>
1,000	–	262774 <sup>1, T</sup>	262780 <sup>1, T</sup>
1,500	–	262775 <sup>1, T</sup>	–
2,000	–	262776 <sup>1, T</sup>	262781 <sup>1, T</sup>

**Table 27 Codes for Dry-Type Network. Three-Phase With 3 Primary Bushings and 3 Secondary Bushings – Conventional, 65/115° Rise Cast Coil, In-Line Layout**

kVA	12,000 – 208Y/120 V	12,000 – 480Y/277 V	34,500GrdY/19,920 480Y/277 V
500	–	–	–
750	–	–	262816 <sup>1, T</sup>
1,000	–	262813 <sup>1, T</sup>	262817 <sup>1, T</sup>
1,500	–	262814 <sup>1, T</sup>	–
2,000	–	262815 <sup>1, T</sup>	262818 <sup>1, T</sup>

**Table 28 Codes for Pad-Mount Network, Three-Phase With 3 Primary Bushings and 3 Secondary Bushings (reference [Document 045774](#) and [Spec. 86](#)) – Conventional, Mild Steel**

kVA	12,000 – 480Y/277 V	34,500GrdY/19,920 – 480Y/277 V
750	260666 <sup>1</sup>	260655 <sup>1</sup>
1,000	260667 <sup>1</sup>	260656 <sup>1</sup>
1,500	260684 <sup>1</sup>	260657 <sup>1</sup>
2,000	260699 <sup>1</sup>	260658 <sup>1</sup>

<sup>1</sup> Current standard design and may be purchased.<sup>4</sup> Use for replacement only and may be purchased.

E Included in Emergency Stock

T With high voltage taps

## Application of Underground Distribution Transformers

**Specialty Transformers (continued)****Table 29 Codes for System Tie, Three-Phase, Pad-Mount With 3 Primary Bushings and 3 Secondary Bushings (reference [Document 068184](#) and [Spec. 86](#)) – Conventional, Mild Steel**

kVA	12,000/20,780GrdY/12,000 - 4,160GrdY/2,400 V 0° Phase Shift @ 21 kV 30° Phase Shift @ 12 kV	12,000 -4,800	6,930/12,000Y - 4,160Y/2,400 V 0° Phase Shift @ 12 kV	20780 - 4,160GrdY/2,400 V 30° Phase Shift @ 21 kV
	With One Recloser on Secondary Side			
2,500	261381 <sup>1, E</sup>	-	262578 <sup>1, E</sup>	262579 <sup>1, E</sup>
3,000	-	262696 <sup>1, E</sup>	-	

**Table 30 Codes for System Tie, Three-Phase, Pad-Mount With 3 Primary Bushings and 3 Secondary Bushings (reference [Document 051119](#) and [Spec. 86](#)) (continued) – Conventional, Mild Steel**

kVA	20,780Y/12,000		17,200 V Delta	
	12,000Y/6,930 V		12,000Y/6930 V	
	Without Recloser	With 2 Reclosers	30° Lead to 30° Lag Switch With Recloser on 21 kV Side	30° Lead to 30° Lag Switch Without Recloser
3,600	264134 <sup>1</sup>	262661 <sup>1, E</sup>		261151 <sup>1, E, T</sup>
7,500	261943 <sup>1</sup>	262473 <sup>1, E</sup>	262573 <sup>1, E, T</sup>	

**Table 31 Codes for Pad-Mount, Grounding Bank, Three-Phase, (for cogeneration fault sensing with Ho bushing, 2.5% impedance) With 6 Primary Bushings and 3 Secondary Bushings (reference [Document 062264](#) and [Spec. 86](#)) – Self-Protected, Mild Steel**

kVA	20,780GrdY/12,000 - 480 V Delta
225	017072 <sup>1</sup>

**Table 32 Codes for Zigzag, Radial Dead-Front, Three-Phase, Pad-Mount With 2 Primary Bushings and 4 Secondary Bushings Including the Insulated Neutral (reference [Document 045786](#) and [Spec. 86](#)) – Conventional, Mild Steel**

kVA	20,780GrdY/12,000	
	208Y/120 V	480Y/277 V
300	263073 <sup>1, E</sup>	263076 <sup>1, E</sup>

**Single-Phase, Pad Mount, for Replacements Only****Table 33 Codes for Live-Front, Clam Shell, Single-Phase, Pad-Mount With 2 Primary Bushings and 2 Hot Secondary Bushings. Neutral May Be Permanently Grounded. (reference [Document 042761](#) and [Spec. 86](#)) – Self-Protected**

kVA	With Single-Phase Cabinet		
	12,000GrdY/6,930 - 240/120 V	12,000/20,780 GrdY - 240/120 V	
	Mild Steel	Mild Steel	Stainless Steel
50	-	263002 <sup>4</sup>	263037 <sup>4</sup>
100	261274 <sup>4, E</sup>	263004 <sup>4, E</sup>	263038 <sup>4, E</sup>
167	261275 <sup>4, E</sup>	263016 <sup>4, E</sup>	263039 <sup>4</sup>

<sup>1</sup> Current standard design and may be purchased.<sup>4</sup> Use for replacement only and may be purchased.  
<sup>E</sup> Included in Emergency Stock  
<sup>T</sup> With high voltage taps

## Application of Underground Distribution Transformers

**Single-Phase, Pad Mount, for Replacements Only (continued)****Table 34 Codes for Live-Front, Clam Shell, Single-Phase, Pad-Mount With 3 Primary Bushings and 2 Hot Secondary Bushings. Neutral May Be Permanently Grounded. (reference [Document 042761](#) and [Spec. 86](#)) (continued) – Self-Protected**

kVA	With Three-Phase Cabinet					
	12,000GrdY/6,930 240/120	4,160X12,000 240/120 V	12,000/20,780 GrdY – 240/120 V		17,200 240/120 V	20,780 240/120 V
	Mild Steel	Mild Steel	Mild Steel	Stainless Steel	Mild Steel	Mild Steel
50	–	263014 <sup>4, E</sup>	263006 <sup>4, E</sup>	263040 <sup>4, E</sup>	263010 <sup>4, E</sup>	263044 <sup>4</sup>
100	261276 <sup>4, E</sup>	263015 <sup>4, E</sup>	263008 <sup>4, E</sup>	263041 <sup>4, E</sup>	263012 <sup>4, E</sup>	263045 <sup>4, E</sup>
167	261277 <sup>4, E</sup>	263019 <sup>4, E</sup>	263017 <sup>4, E</sup>	263042 <sup>4</sup>	263018 <sup>4, E</sup>	263046 <sup>4, E</sup>

**Single-Phase, Subsurface Round, for Replacements Only****Table 35 Codes for Subsurface Round, Single-Phase, 3 Secondary Bushings With Insulated Neutral. Use as the Power Transformer in the Bank. (reference [Document 035313](#) and [Spec. 91](#)) – Self-Protected, Stainless Steel**

kVA	4,160/7,200Y – 240/120 V 4 Primary Bushings		4,160GrdY/2,400 – 240/120 V 2 Primary Bushings		12,000/20,780GrdY 240/120 V 4 Primary Bushings	17,200 – 240/120 V 4 Primary Bushings
	No Switch	With Single-Phase Switch	No Switch	With Single-Phase Switch	No Switch	No Switch
25	262362 <sup>4 E</sup>	262316 <sup>4</sup>	–	–	–	–
50	–	–	–	–	–	262314 <sup>4</sup>
75	–	–	262328 <sup>4</sup>	–	–	–
100	–	–	–	–	262283 <sup>4, E</sup>	–
167	–	–	–	–	262284 <sup>4, E</sup>	–

**Table 36 Codes for Subsurface Round Single-Phase With 3 Secondary Bushings, Neutral May Be Permanently Grounded. Use to Supply Single-Phase Load or as the Lighting Transformer in a Bank. (reference [Document 035313](#) and [Spec. 91](#)) – Self-Protected, Stainless Steel**

kVA	4,160/7,200Y 240/120 V 4 Primary Bushings	4,160GrdY/2,400 240/120 V 2 Primary Bushings		12,000/20,780GrdY 240/120 V 4 Primary Bushings		12,000/20,780GrdY 480/240 V 4 Primary Bushings
	No Switch	No Switch	With Single-Phase Switch	No Switch	With Single-Phase Switch	No Switch
25	–	–	–	–	–	262307 <sup>1, E</sup>
50	–	–	–	262058 <sup>4, E</sup>	262096 <sup>4, E</sup>	–
75	–	–	–	–	–	262324 <sup>4, E</sup>
100	(see Table 7 on Page 6)			262060 <sup>4, E</sup>	262098 <sup>4, E</sup>	–
167	262372 <sup>4, E</sup>	262121 <sup>4, E</sup>	262144 <sup>4</sup>	262062 <sup>4, E</sup>	262099 <sup>4, E</sup>	–

<sup>1</sup> Current standard design and may be purchased.<sup>4</sup> Use for replacement only and may be purchased.  
<sup>E</sup> Included in Emergency Stock

## Application of Underground Distribution Transformers

**Single-Phase, Subsurface Round, for Replacements Only (continued)****Table 37 Codes for Subsurface Round, Single-Phase With 3 Secondary Bushings, Neutral May Be Permanently Grounded. Use to Supply Single-Phase Load or as the Lighting Transformer in a Bank. (reference [Document 035313](#) and [Spec. 91](#)) (continued) – Self-Protected, Stainless Steel**

kVA	12,000GrdY/6,930 240/120 V 2 Primary Bushings		17,200 240/120 V 4 Primary Bushings		20,780GrdY/12,000 240/120 V 2 Primary Bushings		20,780GrdY/12,000 480/240 V 2 Primary Bushings	
	No Switch	With Single-Phase Switch	No Switch	No Switch	No Switch	With Single- Phase Switch	No Switch	With Single- Phase Switch
25	-	-	-	-	-	-	262321 <sup>1, E</sup>	262303 <sup>1, E</sup>
50	262054 <sup>4, E</sup>	262090 <sup>4, E</sup>	262186 <sup>4, E</sup>	262147 <sup>4, E</sup>	262153 <sup>4, E</sup>	-	-	-
100	262056 <sup>4, E</sup>	262092 <sup>4, E</sup>	262188 <sup>4, E</sup>	262149 <sup>4, E</sup>	262155 <sup>4, E</sup>	-	-	-
167	262086 <sup>4, E</sup>	262093 <sup>4, E</sup>	262189 <sup>4, E</sup>	262150 <sup>4, E</sup>	262156 <sup>4, E</sup>	-	-	-

**Three-Phase, Pad-Mount, for Replacements Only****Table 38 Codes for Style IIC\*, Three-Phase, Pad-Mount With 3 Primary Bushings and 4 Secondary Bushings Including the Insulated Neutral (reference [Document 045290](#) and [Spec. 86](#)) – Self-Protected**

kVA	4,160X12,000 480Y/277 V Mild Steel	
	1,500	260789 <sup>1</sup>
2,500	260791 <sup>1, E</sup>	

(Style IIC and Style IIF transformers are completely interchangeable except for the primary fuses.)

\*See Table 20 on Page 10 for others of this type.

**Table 39 Codes for Style IIF, Three-Phase, Pad-Mount With 3 Primary Bushings and 4 Secondary Bushings Including the Insulated Neutral (reference [Document 045290](#) and [Spec. 86](#)) – Self-Protected**

kVA	12,000/20,780GrdY/12,000					
	208Y/120		480Y/277		2,400/ 4,160Y/2,400	
	Mild Steel	Stainless Steel	Mild Steel	Stainless Steel	Mild Steel	Stainless Steel
300	261284 <sup>4, E</sup>	-	261288 <sup>4</sup>	262115 <sup>4, E</sup>	-	-
750	261285 <sup>4</sup>	-	261289 <sup>4</sup>	-	-	-
1,000	261286 <sup>4, E</sup>	262114 <sup>4</sup>	261290 <sup>4</sup>	262116 <sup>4, E</sup>	261292 <sup>4</sup>	-
1,500	-	-	261291 <sup>4</sup>	-	261293 <sup>4</sup>	-
2,500	-	-	261328 <sup>4</sup>	262177 <sup>4, E</sup>	261329 <sup>4</sup>	262179 <sup>4, E</sup>

<sup>1</sup> Current standard design and may be purchased.<sup>4</sup> Use for replacement only and may be purchased.  
<sup>E</sup> Included in Emergency Stock



## Application of Underground Distribution Transformers

**Three-Phase, Pad-Mount, for Replacements Only (continued)****Table 40 Codes for Style IIF, Three-Phase, Pad-Mount With 3 Primary Bushings and 4 Secondary Bushings Including the Insulated Neutral (reference [Document 045290](#) and [Spec. 86](#)) (continued) – Self-Protected**

kVA	4,160X12,000		17,200	
	208Y/120	480Y/277	208Y/120	480Y/277
	Mild Steel	Mild Steel	Mild Steel	Mild Steel
300	261281 <sup>4</sup>	261283 <sup>4</sup>	–	261296 <sup>4</sup>
750	261287 <sup>4, E</sup>	261282 <sup>4, E</sup>	261294 <sup>4</sup>	261297 <sup>4</sup>
1,000	–	–	261295 <sup>4, E</sup>	261298 <sup>4, E</sup>
1,500	–	–	–	261299 <sup>4</sup>
2,500	–	–	–	261330 <sup>4, E</sup>

**Table 41 Codes for Style IIH, Three-Phase, Pad-Mount, Live-Front With Vacuum Fault Interrupter, with 3 Primary Bushings and 4 Secondary Bushings With Insulated Neutral With Stainless Steel Cabinet and FR3 Insulating Fluid (reference [Document 072146](#) and [Spec. 86](#))**

kVA	12,000/20,780GrdY/12,000		17,200	
	480Y/277	2,400/4160Y/2,400	480Y/277	
	Mild Steel	Mild Steel	Mild Steel	
2955/3325	262708 <sup>4, E</sup>	262709 <sup>4, E</sup>	262710 <sup>4, E</sup>	

**Table 42 Codes for Radial, Dead-Front\*, Three-Phase, Pad-Mount With 3 Primary Bushings and 4 Secondary Bushings Including the Insulated Neutral (reference [Document 043816](#) and [Spec. 86](#)) (continued) – Conventional**

kVA	12,000/20,780GrdY/12,000		17,200	
	208Y/120 V	480Y/277 V	480Y/277 V	
	Mild Steel	Mild Steel	Mild Steel	
75	260315 <sup>4</sup>	260314 <sup>4</sup>	–	
150	260732 <sup>4</sup>	260317 <sup>4</sup>	–	
300	260682 <sup>4</sup>	260326 <sup>4</sup>	–	
750	260080 <sup>4, E</sup>	260039 <sup>4, E</sup>	260880 <sup>4, E</sup>	
1,000	260107 <sup>4, E</sup>	260041 <sup>4</sup>	260181 <sup>4</sup>	
1,500	–	260002 <sup>4</sup>	260883 <sup>4, E</sup>	
2,500	–	260042 <sup>4, E</sup>	–	

\* See Table 18 on Page 10 for others of this type.

<sup>1</sup> Current standard design and may be purchased.<sup>4</sup> Use for replacement only and may be purchased.<sup>E</sup> Included in Emergency Stock

## Application of Underground Distribution Transformers

**Three-Phase, Pad-Mount, for Replacements Only (continued)****Table 43 Codes for Radial, Live-Front, Three-Phase, Pad-Mount With 3 Primary Bushings and 4 Secondary Bushings Including the Insulated Neutral (reference [Document 043816](#) and [Spec. 86](#)) – Conventional**

kVA	4,160X12,000		17,200	
	208Y/120 V	480Y/277 V	208Y/120 V	480Y/277 V
	Mild Steel	Mild Steel	Mild Steel	Mild Steel
75	260695 <sup>4</sup>	-	260309 <sup>4</sup>	260613 <sup>4</sup>
150	-	-	-	260615 <sup>4</sup>
300	-	-	260289 <sup>4</sup>	260617 <sup>4</sup>
750	260921 <sup>4</sup>	-	-	-

**Table 44 Codes for Radial, Live-Front, Three-Phase, Pad-Mount With 3 Primary Bushings and 4 Secondary Bushings Including the Insulated Neutral (reference [Document 043816](#) and [Spec. 86](#)) (continued) – Conventional**

kVA	12,000/20,780GrdY/12,000	
	208Y/120 V	480Y/277 V
	Mild Steel	Mild Steel
75	260710 <sup>4</sup>	260764 <sup>4</sup>
150	260755 <sup>4</sup>	260766 <sup>4</sup>
300	260757 <sup>4</sup>	260768 <sup>4</sup>
750	260759 <sup>4</sup>	260770 <sup>4, E</sup>
1,000	260760 <sup>4, E</sup>	-
1,500	-	260677 <sup>4</sup>
2,500	-	260773 <sup>4, E</sup>

**Table 45 Codes for Subsurface Vault, Three-Phase With 3 Primary Bushings and 4 Secondary Bushings Including the Insulated Neutral (reference [Document 072138](#) and [Spec. 91](#)) – Conventional, Plate Steel**

kVA	12,000/20,780GrdY/12,000 – 208Y/120 V	12,000/20,780GrdY/12,000 – 480Y/277 V
300	262428 <sup>4</sup>	-
750	262430 <sup>4</sup>	262432 <sup>4</sup>
1,000	262107 <sup>4, E</sup>	262433 <sup>4, E</sup>
1,500	-	262434 <sup>4</sup>
2,500	-	015641 <sup>4, E</sup>

**Table 46 Power Interconnection Hub (PIH) Transformers – for usage only on specific designated projects. Contains Quick Connect Cabinet on 480V Secondary.**






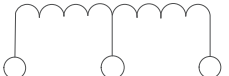
mVA	Primary	Secondary	Mild Steel
2.5	20780 GrdY/12000	480Y/277	263175
2.5	12000 GrdY/6930	480Y/277	263176
2.5	17200 GrdY/9930	480Y/277	263178

<sup>1</sup> Current standard design and may be purchased.<sup>4</sup> Use for replacement only and may be purchased.<sup>E</sup> Included in Emergency Stock

## Application of Underground Distribution Transformers

## Designation of Voltage Ratings of Windings - Single-Phase Transformers

Table 47 Designation of Voltage Ratings of Windings – Single-Phase Transformers

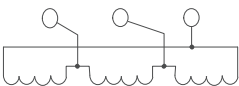
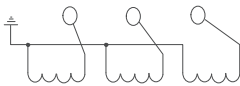
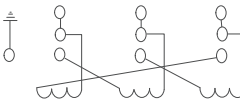
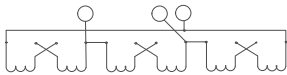
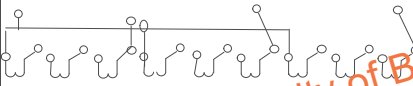
Item	Designation	Typical Voltage Rating	Typical Winding Diagram	Description
1	E	12,000		Indicates a winding of E volts which is suitable for delta connection on an E volt system.
2	E/E <sub>1</sub> Y <sup>1</sup>	2,400/4,160Y		Indicates a winding of E volts which is suitable for delta connection on an E volt system or for wye connection on an E <sub>1</sub> volt system.
3	E/E <sub>1</sub> Grd.Y <sup>1</sup>	12,000/20,780 Grd. Y or 2,400/4,160 Grd. Y		Indicates a winding of E volts having insulation suitable for delta connection on an E volt system or for wye connection on an E <sub>1</sub> volt effectively grounded system.
4	E <sub>1</sub> Grd.Y/E <sup>1</sup>	20,780 Grd. Y/12,000 or 12,000 Grd. Y/6,930		Indicates a winding of E volts which has one end of the winding grounded internally. Windings with one end grounded internally are suitable for single-phase or wye operation on a three-phase E <sub>1</sub> volt effectively grounded system.
5	E/2E	120/240 or 240/480		Indicates a winding, the sections of which can be connected in parallel for operation at E volts, connected in series for operation at 2E volts, or connected in series with a center terminal for 3-wire operation at 2E volts between the extreme terminals and E volts between the center terminal and each of the extreme terminals.
6	2E/E	240/120		Indicates a winding having a mid-tap and suitable for 3-wire operation at 2E volts between extreme terminals and at E volts between the mid-tap and each of the extreme terminals (not reconnectable).

<sup>1</sup> E<sub>1</sub> =  $\sqrt{3}$  E

## Application of Underground Distribution Transformers

## Designation of Voltage Ratings of Windings – Three-Phase Transformers

Table 48 Designation of Voltage Ratings of Windings – Three-Phase Transformers

Item	Designation	Typical Voltage Rating	Typical Winding Diagram	Description
7	E	12,000		Indicates a winding that is permanently delta connected for operation on an E volt system.
8	E <sub>1</sub> Grd.Y/E <sup>1</sup>	20,780 Grd.Y/12,000 or 34,500 Grd.Y/19,920		Indicates a winding that is permanently wye connected with neutral grounded to the tank for operation on an E <sub>1</sub> volt effectively grounded system with E volts available from line to neutral.
9	E/E <sub>1</sub> Grd.Y/E <sup>1</sup>	12,000/20,780 Grd.Y/12,000		Indicates a winding which may be delta connected for operation on an E volt system or may be wye connected for operation on an E <sub>1</sub> volt grounded system with E volts available from line to neutral.
10		4,160 x 12,000		Indicates a permanently delta connected winding for multiple or series operation.
11	V x V <sub>1</sub>	12,000 x 34,500 Grd. Y/19,920		Indicates a winding which may be delta connected for operation on a 12 kV system or wye connected for operation on a 34.5 kV effectively grounded wye system.

<sup>1</sup> E<sub>1</sub> =  $\sqrt{3}$  E

Table 49 Transformer Insulating Fluid Material Codes

	FR3 High-Fire Point Natural Ester	BioTemp High-Fire Point Natural Ester	Mineral Oil	Silicone High-Fire Point
National Standard	ASTM D6871	ASTM D6871	ASTM D3487	ASTM D4652
5 Gallon Pail			M507033	
55 Gallon Drum	M500046		M507034	M500043
Bulk			M507017	

## Application of Underground Distribution Transformers

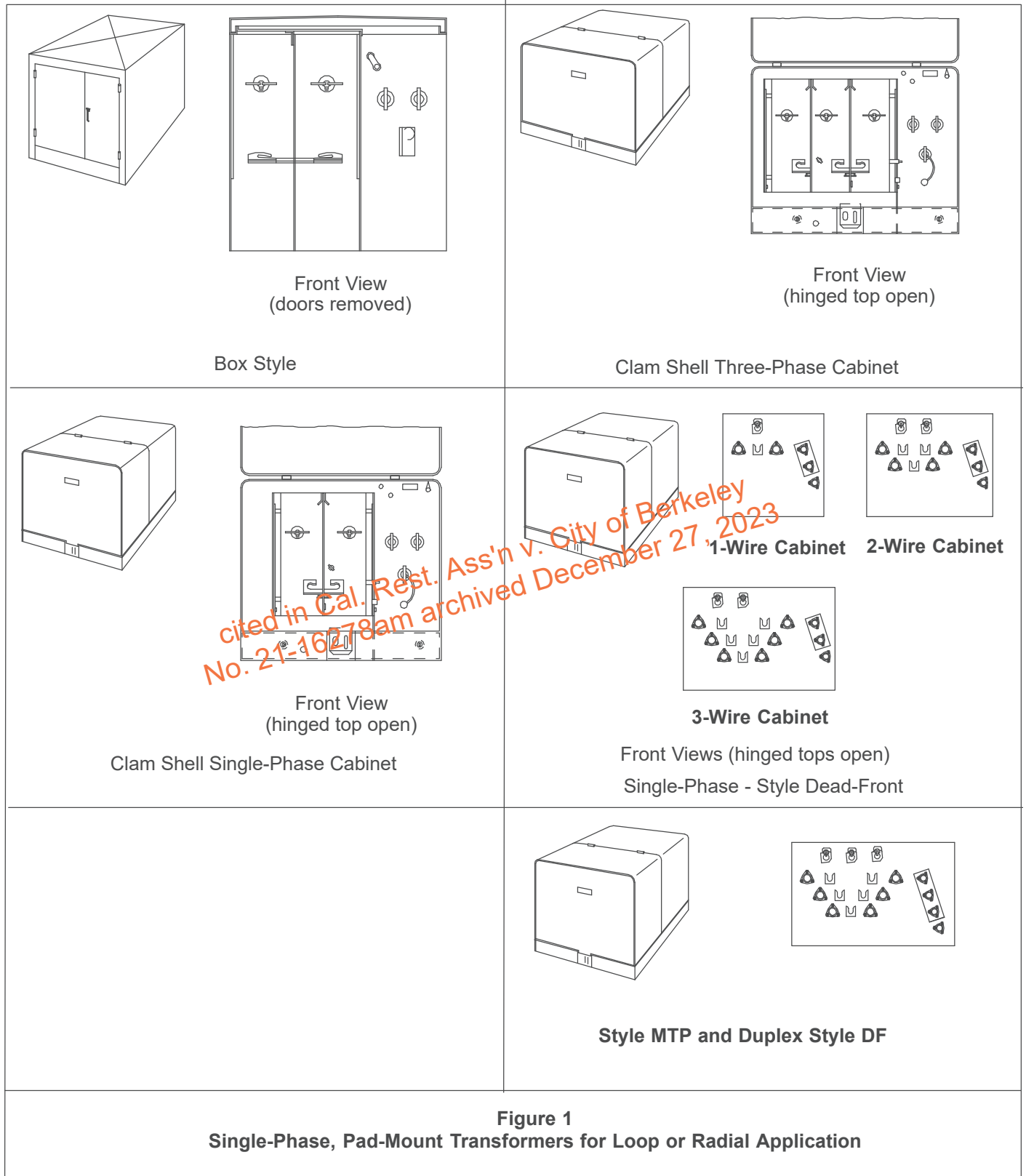
**Primary Voltages****Table 50 System Primary Voltages <sup>1</sup>**

Phase	Primary Voltages	System
Single-Phase	2,400/4,160Y	For 2.4 kV - L-L Connection
Single-Phase	2,400 x 4,800	For 2.4 kV - L-L Connection
Single-Phase	4,160/7,200Y	For 4 kV - L-L Connection
Single-Phase	4,160GrdY/2,400	For 4 kV - 4-Wire L-G Connection
Single-Phase	4,160 x 12,000	For 4 kV - L-L Connection
Single-Phase	4,160 x 7,200	For 4 kV - L-L Connection
Single-Phase	7,200/12,470Y	For 12 kV - 4-Wire L-G Connection
Single-Phase	12,000	For 12 kV L-L or 21 kV L-G Connection
Single-Phase	12,000/20,780 GrdY	For 12 kV L-L or 21 kV L-G Connection
Single-Phase	12,000/20,780Y	For 12 kV L-L or 21 kV L-G Connection
Single-Phase	12,000GrdY/6,930	For 12 kV - 4-Wire L-G Connection
Single-Phase	12,470GrdY/7,200	For Use in Chester
Single-Phase	17,200	For 17 kV L-L Connection
Single-Phase	20,780	For 21 kV L-L Connection
Single-Phase	20,780GrdY/12,000	For 21 kV - 4-Wire L-G Connection
Single-Phase	24,940GrdY/14,400	For Use in Chester
Single-Phase	44,000	For 44 kV - L-L Connection
Single-Phase	44,000/25,400	For 44 kV - L-L Connection
Three-Phase	4,160	For 4 kV - Delta Connection
Three-Phase	4,160GrdY/2,400	For 4 kV - 4-Wire L-G Connection
Three-Phase	4,160 x 12,000	For 4 kV - Delta Connection
Three-Phase	4,160 x 12,480	For 4 kV - Delta Connection
Three-Phase	12,000	For 12 kV - Delta Connection
Three-Phase	12,000/20,780GrdY/12,000	For 12 kV Delta or 21 kV GrdY Connection
Three-Phase	12,000 x 20,780	For 12 kV Delta or 21 kV Delta Connection
Three-Phase	12,000 x 34,500GrdY/19,920	For 12 kV or 34.5 kV Networks
Three-Phase	17,200	For 17 kV Delta Connection
Three-Phase	20,780	For 21 kV Delta Connection
Three-Phase	20,780GrdY/12,000	For 21 kV GrdY Connection
Three-Phase	20,780Y/12,000	For 21 kV Y Connection
Three-Phase	34,500GrdY/19,920	For 34.5 kV Networks

<sup>1</sup> Table 50 is intended to be a reference between the transformer's primary voltage and the type of primary system that it can be used on in the PG&E system.

Application of Underground Distribution Transformers

Pictorial Index



*cited in Cal. Rest. Ass'n v. City of Berkeley  
No. 21-16278am archived December 27, 2023*

Application of Underground Distribution Transformers

Pictorial Index (continued)

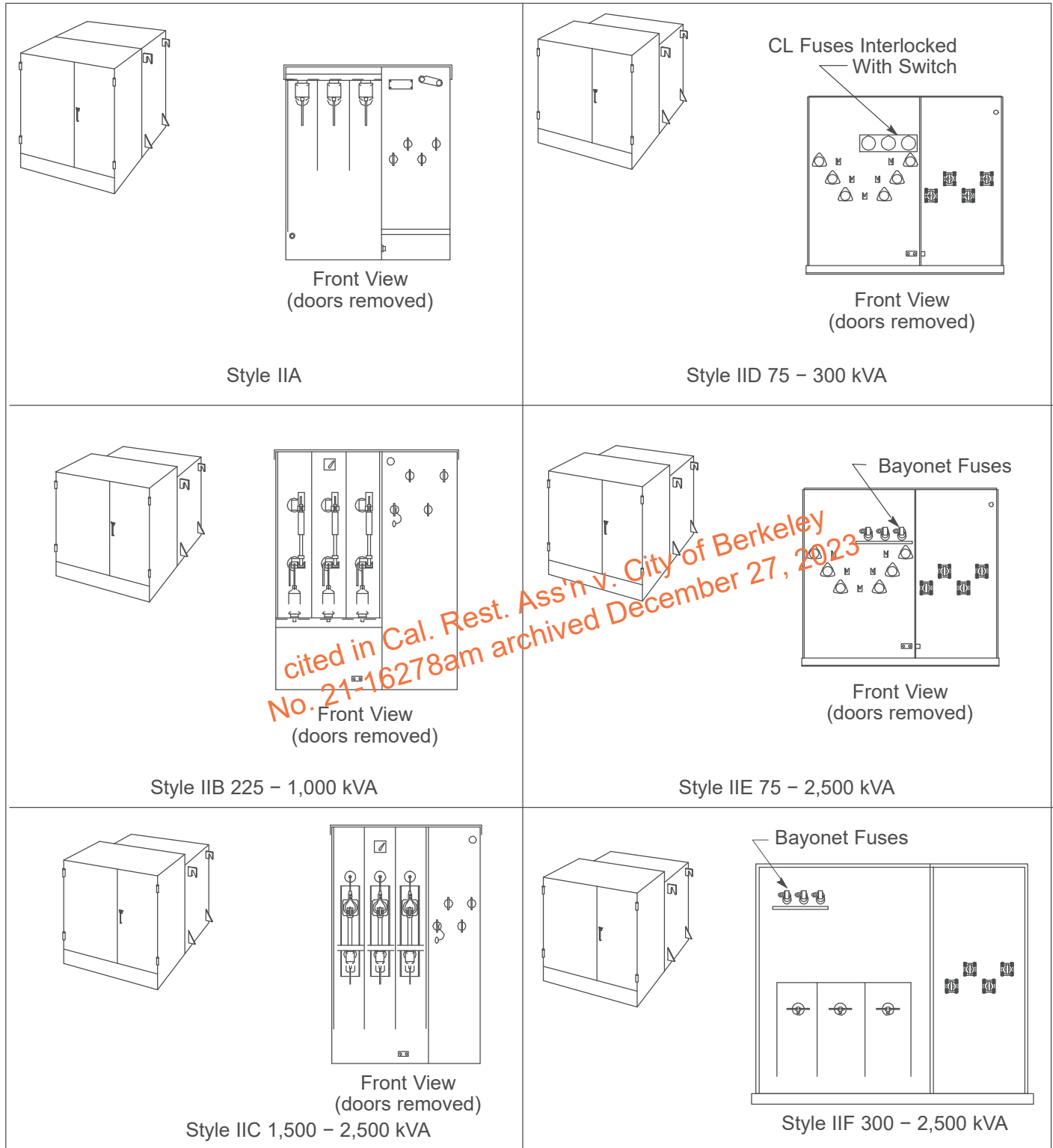
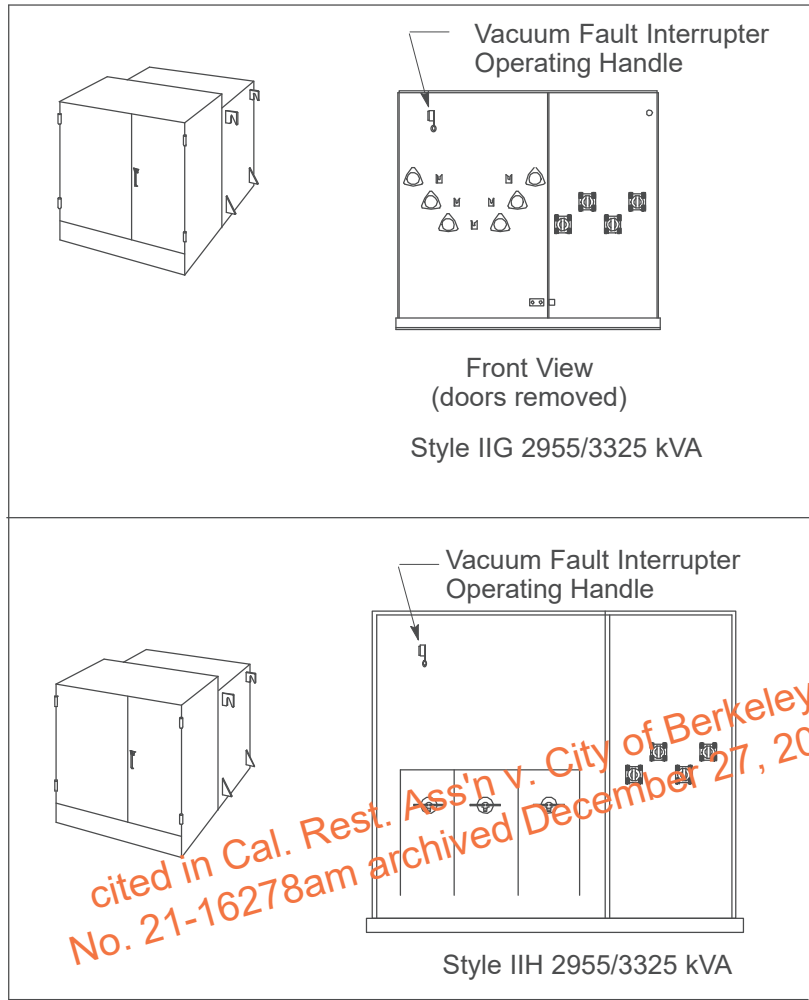


Figure 2  
Three-Phase, Pad-Mount Transformers for Loop or Radial Application

### Application of Underground Distribution Transformers

#### Pictorial Index (continued)

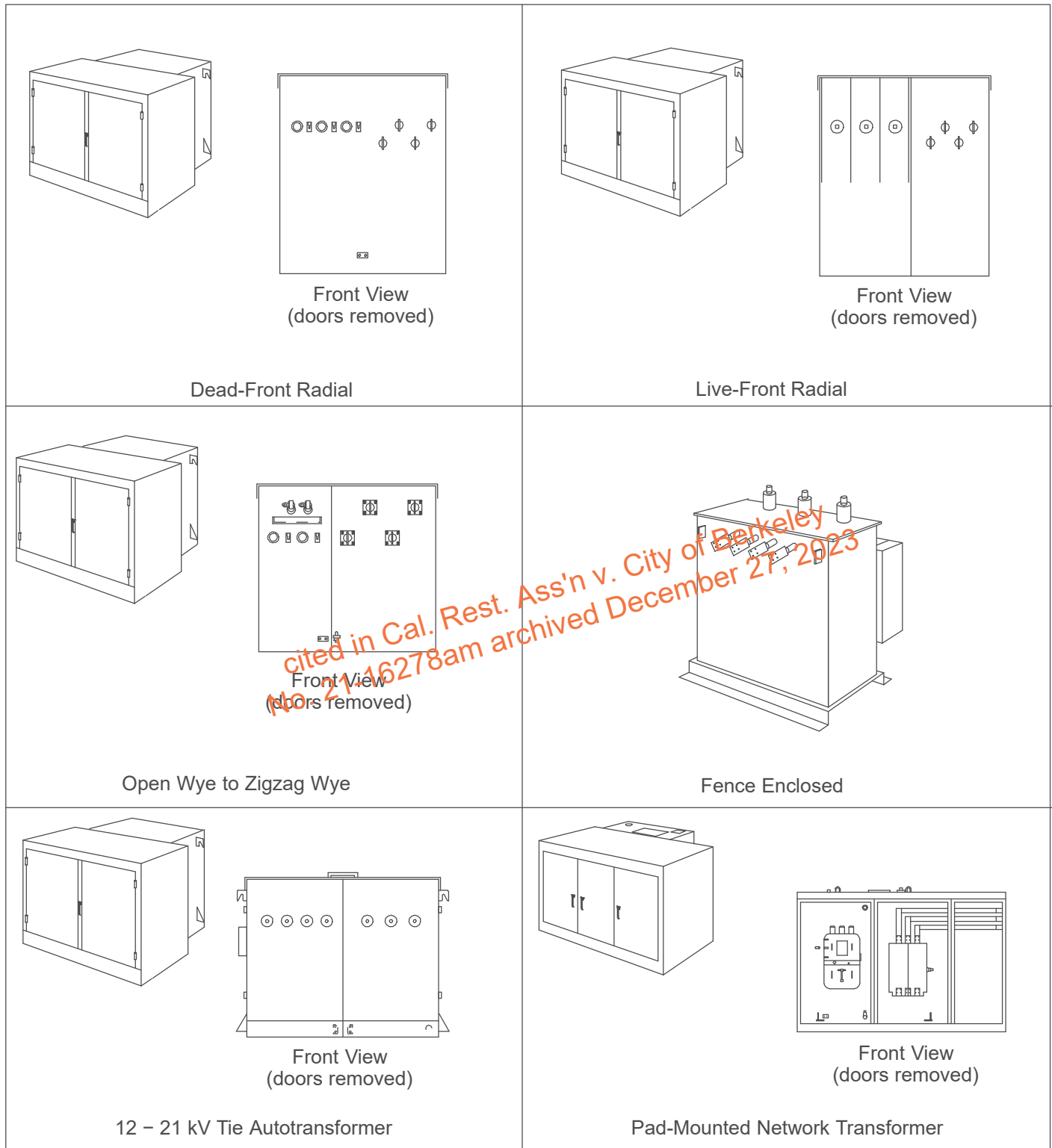


**Figure 3**  
**Three-Phase, Pad-Mount Transformers for Loop or Radial Application**



### Application of Underground Distribution Transformers

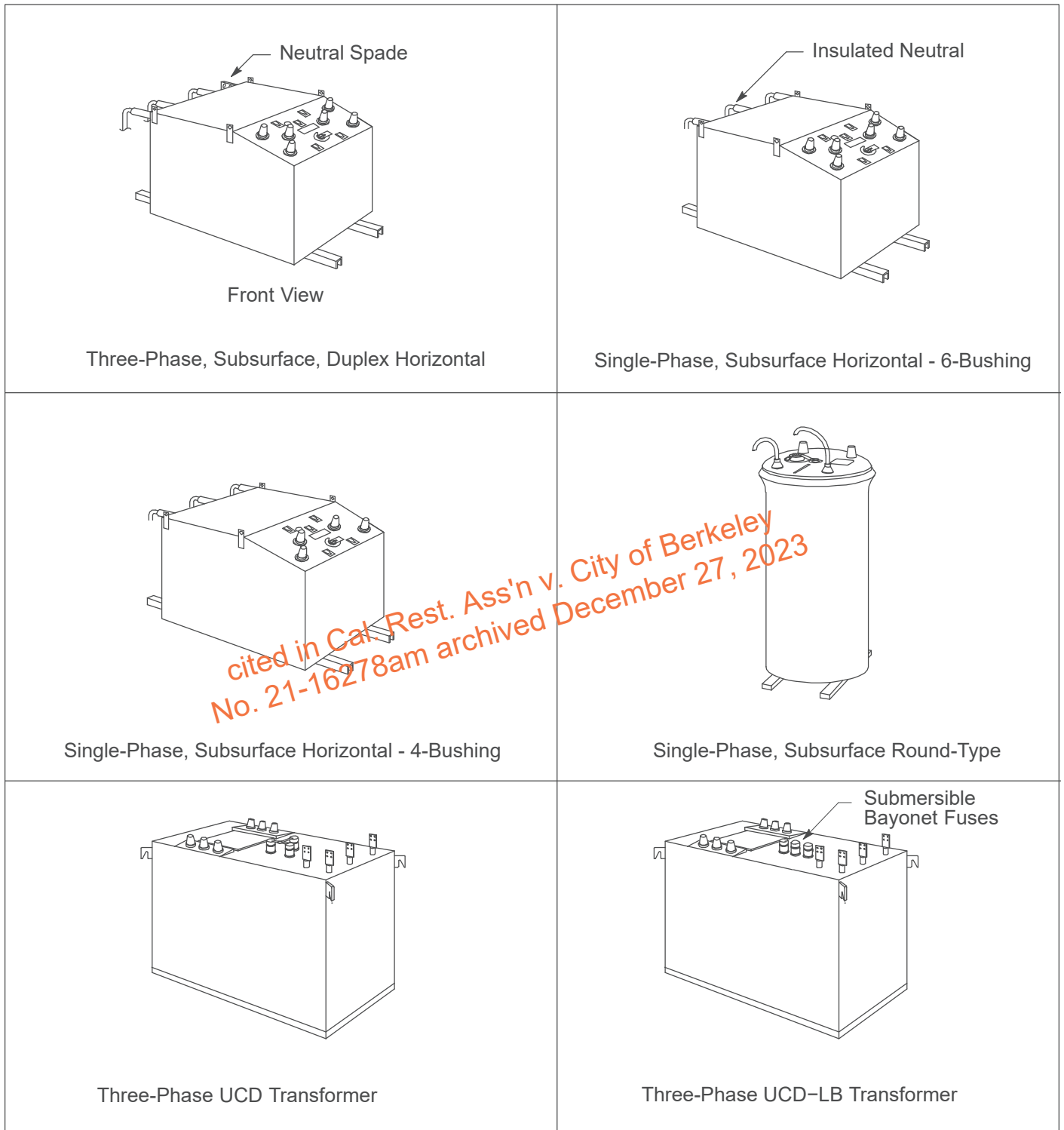
#### Pictorial Index (continued)



**Figure 4**  
**Three-Phase, Pad-Mount Transformers for Radial Application**

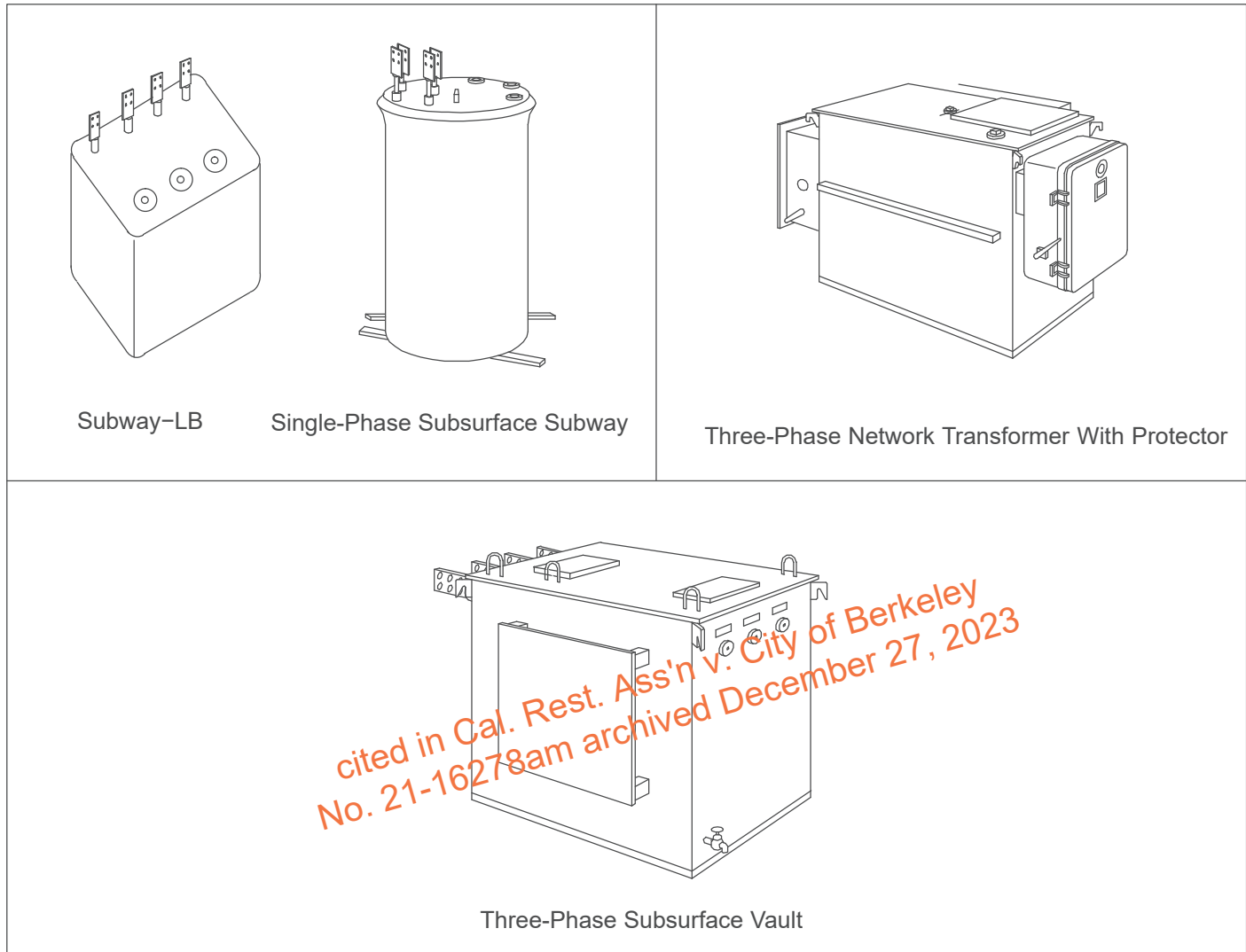
### Application of Underground Distribution Transformers

#### Pictorial Index (continued)



**Figure 5**  
**Subsurface Transformers for Loop or Radial Application**

**Pictorial Index (continued)**




**Figure 6**  
**Subsurface Transformers for Radial Application**

**Revision Notes**

Revision 27 has the following changes:

- 1. Added Table 46 on Page 17.

Prepared by: MZGD

	<b>UNDERGROUND CONDUITS</b>	<b>062288</b>
<b>Asset Type:</b> Electric Distribution	<b>Function:</b> Design and Construction	
<b>Issued by:</b> Lisseth Villareal (LDV2) <i>Lisseth Villareal</i>	<b>Date:</b> 03-25-22	
<b>Rev. #20:</b> This document replaces PG&E Document 062288, Rev. #19 For a description of the changes, see Page 20.		

**Purpose and Scope**

This document covers steel and plastic conduit for electric underground installations, with or without concrete encasement.

**General Information**

1. Applications for underground conduit are as follows:

- A. Residential: All residential installations requiring conduit should be made without concrete encasement.
- B. Light Commercial, Industrial, and Underground Residential Distribution (URD) Feeder: Installation of circuits of this type, which are three-way or less, should normally be made without concrete encasement. In densely populated urban areas, conduit banks involving more than three primary conduits may require concrete encasement.
- C. Severe exposure to “dig-ins” and other hazards may require concrete encasement of conduit lines.
  - (1) Conduit separation for concrete encasement of conduit lines using spacers to avoid obstacles is illustrated on Page 15.
  - (2) Conduit separation for concrete encasement of conduit lines terminating into a manhole or vault, is illustrated on Page 16.
  - (3) Conduit separation for concrete encasement of conduit lines terminating into an enclosure is illustrated on Page 17.

2. For the minimum design requirements for trenches and conduits installed in PG&E electric distribution system see [Document 038193](#). Trench requirements previously listed in this document have been moved to [Document 038193](#).

3. For the design requirements of conduits installed specifically on bridges see [Utility Procedure TD-2310P-10](#).

4. In April of 2020, PG&E stopped purchasing rigid Polyvinyl Chloride (PVC) DB-120 for conduits, couplings, fittings, and bends for installation in its electric distribution system. PG&E now purchases rigid single wall or co-extruded cellular core wall PVC Schedule 40 conduits, couplings, fittings and bends as the standard conduit type for open trench installations.

5. Rigid single wall or co-extruded cellular core wall PVC Schedule 40 conduits, couplings, fittings, and bends are interchangeable with rigid PVC DB-120 conduits, couplings, fittings, and bends, respectively. This interchangeability is possible because DB-120 and rigid PVC Schedule 40 materials have the same outside diameters.

6. When conduit, including service conduit, is to be installed for PG&E by others, the conduits must meet the requirements listed in this document. The conduit listed below are also acceptable alternatives to the required Rigid single wall or co-extruded cellular core wall PVC Schedule 40.

- A. Single wall and co-extruded cellular core wall PVC Schedule 80, UL 651 approved conduit that is so marked.
- B. Hot-dip galvanized rigid steel conduit conforming to American National Standards Institute (ANSI) Specification C80.1.

## Underground Conduits

It is the installer's responsibility to use the proper fitting to join conduits. This transition may involve changes in both conduit type and size. If equal diameter conduits of different wall thicknesses are joined, the inside edge of the spigot end must be chamfered.

7. The current carrying capacity of an insulated cable is reduced if it is surrounded by other loaded cables. For this reason, conduit banks should be arranged so that each conduit is in an outside position.
8. In commercial distribution systems, consideration should be given to providing one or more spare conduits in the original construction for future load growth requirements. The addition of such conduits at a later time is much more costly.
9. A mandrel must be used to prove that all conduits are free and clear of dirt, rocks, and other debris. For further information refer to [Greenbook 3.4.1](#).
10. A pulling tape with sequential footage markings (**Material Code M560154**) must be installed in all conduits and attached to an end cap. The tape must be proven free and not glued or caught on joints.
11. All conduits must be capped. All conduits not terminating in a subsurface enclosure, pedestal, or vault are to be capped with unglued rigid caps (see Table 12 on Page 8). Conduits terminating in a subsurface enclosure, pedestal, or vault must be capped with temporary plugs (see Table 12 on Page 8).
12. Every effort should be made to obtain a straight, watertight conduit line.
13. When the intrusion of water into buildings can be reasonably expected through lateral service ducts, PG&E is responsible for sealing both ends of the conduit (refer to [Document 063927](#) and [Document 063928](#)). The Rayflute Duct Sealing System (RDSS) conduit sealing system can be ordered for this purpose. RDSS must be used when waterproofing a subsurface transformer enclosure is required. Refer to [Document 072149](#).

## Material Specifications

14. PVC conduits and fittings must comply with PG&E engineering material specification [EIMS 61](#) which meet the following industry specifications:
  - A. Tensile modulus of 500,000 psi.
  - B. National Electric Manufacturers Association (NEMA): NEMA TC-2 for straight conduit, couplings and NEMA TC-3 for fittings and bends
  - C. Underwriters Laboratory (UL): UL 651 or Electrical Testing Labs (ETL) that conforms to UL 651.
  - D. UL 651 or ETL conforms to UL 651 must be marked on the outside wall of the PVC schedule 40.
  - E. Rigid solid and single wall or co-extruded cellular core wall PVC Schedule 40 conduits, couplings, fittings, and bends must be gray in color.
  - F. Marking must conform to UL 651 requirements.

## Application

15. PVC conduit may be cut with a hacksaw or a fine-toothed wood saw. Clean off burrs. Bevel the inside to eliminate sharp edges.
16. For PVC conduit, apply a thin, uniform coat of cement to both surfaces to be glued. Avoid excessive use of cement to prevent the formation of a bead of cement on the interior shoulder of the joint since, when hardened, the bead can cause cable damage during installation. Immediately after applying the coat of cement to the conduit, insert the conduit into the fitting socket until it bottoms at the fitting shoulder. Turn the conduit 1/4 turn during insertion to distribute the cement evenly. Hold the conduit in place for about 1 minute to prevent backing out in case of tight interference fit joints. Wipe any excess cement away from the outside of the joint. Weather conditions may vary the curing time. When using cement in confined areas, adequate ventilation must be provided. Table 1 below shows the codes to order PG&E approved conduit cement.

Table 1 Cement for Use With Plastic Conduits

Application	Quantity	Approved Manufacturer and Part Number		Material Code
		Oatey	Weld-on Duit 413	
PVC to PVC	1 Quart	30886	12089	490157
	1 Pint	30885	12090	490151

## Underground Conduits

17. Use end bells fittings to terminate all conduits, unless the conduit has been terminated in an enclosure equipped with duct terminators. Use cable protectors on reconstruction projects only, when end bells cannot be installed.
18. In applications where a conduit dead-ends, cap the end of the conduit and place a marker ball (material code **M374947**, Refer to [M-60](#) for more information) at the location. Identify the marker ball in construction drawings.
19. Conduits shown in Table 10 (HDPE) and Table 11 (PVC, Bore-Gard schedule 40) on Page 7 are for horizontal directional drilling (HDD) trench-less applications only. However, they can also be used in open trench applications.
- A. Mechanical couplings and newly approved Shur-lock II couplers (See Figure 31 and Table 24 on Page 14 ) can be used for joining HDPE to HDPE conduits as well as HDPE to PVC conduits.
20. **Caution:** When pulling conduit(s) in boring applications, be certain to cut the conduits allowing sufficient extra length for the conduit to relax. It may take as long as 72 hours for an excessively stretched conduit to fully relax.
21. **Caution:** Do not use Snap-N-Stack Combo Spacers in concrete encased application.
22. Conduit shown on Table 20 through Table 23 (flexible conduit) on Page 11 through Page 14 are for use in areas with minor soil settlement issues, and for large radius sweeps or re-routes.
23. Backfill containing large rock, paving material, cinders, large amounts of sharply angular substance, or corrosive material must not be placed in excavations where such material may damage conduits, prevent adequate compaction of the fill, or contribute to corrosion of the conduits. Soil compaction must meet PG&E's and any applicable federal, state, county, and local requirements. PG&E specific soil compaction requirements are as follows:
- A. Trenches that run across or along public roads and streets in the franchise areas must have soil compacted to a minimum of 95% density.
- B. Trenches that run across private properties and in all other areas must have soil compacted to a minimum of 90% density.
- C. A compaction test report may be required by PG&E. This report must include the testing company information: Name, Address, Contact Information.

References	Location	Document
<a href="#">Minimum Requirements for the Design and Installation of Conduit and Insulated Cable</a> .....	<a href="#">UG-1: Cable/Greenbook</a> .....	<a href="#">038193</a>
<a href="#">Methods and Requirements for Installing Residential Underground Electric Services 0-600 V to Customer-Owned Facilities</a> .....	<a href="#">UG-1: Services/Greenbook</a> .....	<a href="#">063927</a>
<a href="#">Methods and Requirements for Installing Commercial Underground Electric Services 0-600 Volts to Customer-Owned Facilities</a> .....	<a href="#">UG-1: Services/Greenbook</a> .....	<a href="#">063928</a>
<a href="#">Selection of the Type of Underground Equipment</a> ....	<a href="#">UG-1: General/Greenbook</a> .....	<a href="#">072149</a>
<a href="#">Engineering Material Specification 63, "High Density Polyethylene (HDPE) Conduits and Fittings"</a> .....	<a href="#">TIL</a> .....	<a href="#">EMS 63</a>
<a href="#">Engineering Material Specification 64, "Polyvinyl Chloride (PVC), Conduits, and Fittings"</a> .....	<a href="#">TIL</a> .....	<a href="#">EMS 64</a>
<a href="#">Engineering Material Specification 4123, "Backfill Sand"</a> .....	<a href="#">TIL</a> .....	<a href="#">EMS4123</a>
<a href="#">Electric Distribution Conduits Installed on Bridges</a> ....	<a href="#">TIL</a> .....	<a href="#">TD-2310P-10</a>
<a href="#">Request for Variance from Electric Distribution Standards</a> .....	<a href="#">TIL</a> .....	<a href="#">TD-2951P-01</a>
<a href="#">Approved "Mark and Locate" Instruments, Equipment, Accessories, and Products</a> .....	<a href="#">TIL</a> .....	<a href="#">M60</a>

### Underground Conduits

#### Rigid Steel Conduit and Fittings

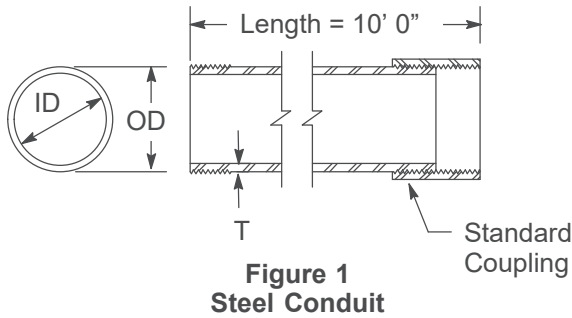


Table 2 Material Material Codes for Rigid Steel Conduit

Conduit Size (inches)	Dimensions (inches)			Weight (lbs.) <sup>1</sup>	Material Code
	OD	ID	T		
2	2.4	2.06	0.154	33	362103
3	3.5	3.06	0.216	69	362092
4	4.5	4.02	0.237	98	362093
5	5.6	5.04	0.258	134	362104
6	6.6	6.06	0.280	177	362141

<sup>1</sup> Weight for one 10-foot length, including one standard coupling furnished with each length.

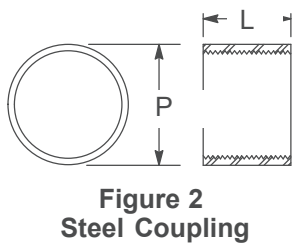


Table 3 Material Codes for Standard Steel Coupling

Conduit Size (inches)	Dimensions (inches)		Material Code
	P	L	
2	2.73	2.18	362105
3	4.00	3.25	362094
4	5.00	3.50	362095
5	6.29	3.75	362106
6	7.39	4.00	362142

*cited in Cal. Rest. Ass'n v. City of Berkeley No. 21-16278am archived December 27, 2023*

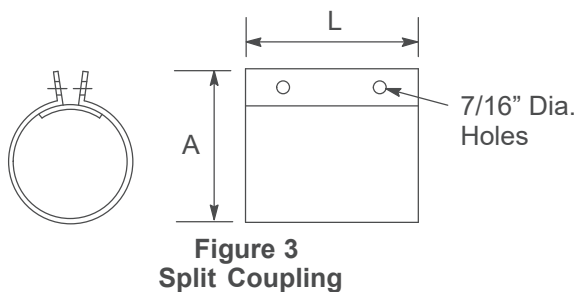


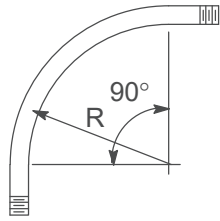
Table 4 Material Codes for Galvanized Steel Split Coupling

Conduit Size (inches)	Dimensions (inches)		Material Code
	A	L	
2	2.5	9	362019
3	3.5	9	362021
4	4.5	9	362023
5 <sup>1</sup>	5.5	9	362107
6 <sup>1</sup>	6.5	9	362143

<sup>1</sup> These sizes are made of zinc-plated malleable iron. Can be installed on rigid steel conduits.

**Underground Conduits**

**Rigid Steel Conduit and Fittings (continued)**



**Figure 4**  
**Conduit Sweep**  
**Threaded Both Ends**

**Table 5 Material Codes for 90° Steel Conduit Sweeps, TBE**

Conduit Size (inches)	Radius (inches)	Material Code
2	24	360081
3	36	362091
4	36	362090
	60	360812
5	36	362109
6	36	362144
	48	362145
	60	360813

*cited in Cal. Rest. Ass'n v. City of Berkeley  
No. 21-16278am archived December 27, 2023*



### Underground Conduits

### PVC and HDPE Conduit and Fittings

#### Notes

- The depth of all couplings, adapters, swedge reducers, and bell ends must conform to the requirements listed in Table 2 of [ASTM Standard F512](#).

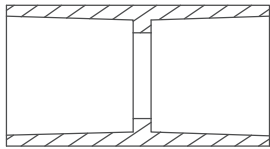


**Figure 5**  
Rigid Plastic Conduit

**Table 6 Data and Material Codes for Rigid Plastic Conduit Schedule 40<sup>1</sup>**

Conduit Size (inches)	Dimensions (inches)				Material Code
	Average Outside Diameter	Minimum Inside Diameter	Wall Thickness		
			Minimum	Maximum	
2	2.375	2.021	0.154	0.113	360153
3	3.500	3.008	0.216	0.148	016471
4	4.500	3.961	0.237	0.184	016472
5	5.563	4.975	0.258	0.221	016473
6	6.625	5.986	0.280	0.257	016474

<sup>1</sup> See Note 14 on Page 2 for material specifications.

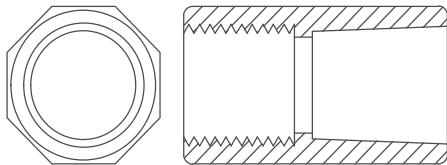


**Figure 6**  
PVC Coupling



**Table 7 Material Codes for PVC Swedge Couplings**

Swedge Coupling		
Conduit Size (inches)	Minimum Socket Depth	Material Code
2	2.25	360321
3	3.25	360322
4	3.75	360323
5	4.25	360401
6	4.75	360482

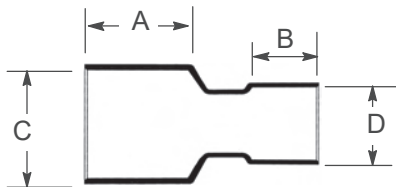


**Figure 7**  
Plastic-to-Steel Adapter



**Table 8 Material Codes for Plastic-to-Steel Adapters**

Conduit Size (inches)	Minimum Socket Depth	Maximum Socket Depth	Material Code
2	1.125	2.00	360324
3	1.594	3.125	360325
4	1.750	3.375	360326
5	1.937	3.625	360402
6	2.125	3.750	360489



**Figure 8**  
Swedge Reducer

**Table 9 Data and Material Codes for PVC Swedge Reducers<sup>1</sup>**

Reducer Size (inches)	Dimensions (inches)				Material Code
	Minimum Length		Typical Belled End ID		
	A	B	C	D	
3 x 2	2.875	1.750	3.515	2.393	018585
4 x 3	3.375	2.875	4.515	3.515	018584
5 x 4	4.000	3.375	5.593	4.515	360777
6 x 5	5.000	4.000	6.658	5.593	360778

<sup>1</sup> Both belled ends must be chamfered 0.3 inches (min) by 45°.

Underground Conduits

PVC and HDPE Conduit and Fittings (continue)

Table 10 High Density Polyethylene (HDPE) Conduit Directional Boring Conduit <sup>1</sup>



Figure 9  
HDPE Conduit

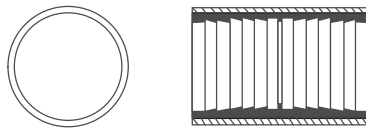
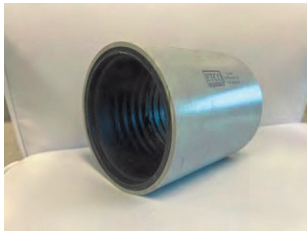


Figure 10  
PE Mechanical Coupling

Conduit				Mechanical Couplings <sup>2, 3</sup>	
Size	Length (feet)	Description	Material Code	Size (inches)	Material Code
2" Sch 80	500	Coil <sup>4</sup>	360511	2	360690
2" Sch 80	40	Stick	360017		
3" Sch 80	500	Coil <sup>4</sup>	360644	3	360691
3" Sch 80	40	Stick	360018		
4" Sch 80	625	Coil <sup>5</sup>	360014	4	360692
4" Sch 80	40	Stick	360015		
5" SDR 13.5	450	Coil <sup>5</sup>	360012	5	360694
5" SDR 13.5	40	Stick	360013		
6" SDR 13.5	450	Coil <sup>5</sup>	360010	6	360695
6" SDR 13.5	40	Stick	360011		

<sup>1</sup> Color must be black with at least 3 red longitudinal strips.

<sup>2</sup> May be used to connect PE conduit to PVC conduit (except in directional drilling apps.)

<sup>3</sup> Mechanical couplings are not designed for directional drilling. Fusion joints are required.

<sup>4</sup> No reel.

<sup>5</sup> With reel.

*cited in Cal. Res. Ass'n v. City of Berkeley  
No. 21-16278 am archived December 27, 2023*

Table 11 PVC (Bore-Gard) Directional Boring Conduit



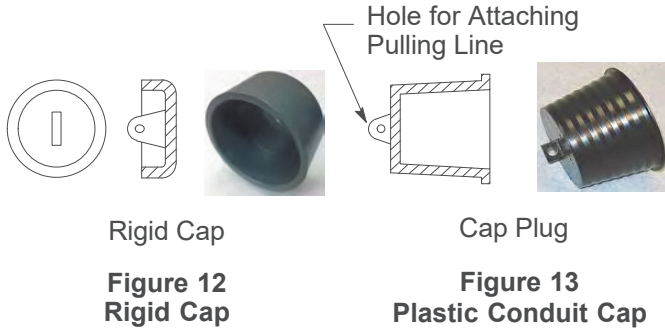
Figure 11  
PVC (Bore-Gard, Schedule 40)

Size (inches)	Description	Material Code
3	Conduit 10', Schedule 40	360055
3	Conduit 20', Schedule 40	360056
4	Conduit 10', Schedule 40	360026
4	Conduit 20', Schedule 40	360025
4	Replacement Locking Straps <sup>1</sup>	360031
4	Replacement Seal Gaskets <sup>1</sup>	360029
6	Conduit 10', Schedule 40	360027
6	Conduit 20', Schedule 40	360028
6	Replacement Locking Straps <sup>1</sup>	360032
6	Replacement Seal Gaskets <sup>1</sup>	360030

<sup>1</sup> Package of 10.

Underground Conduits

PVC Conduit and Fittings (continued)

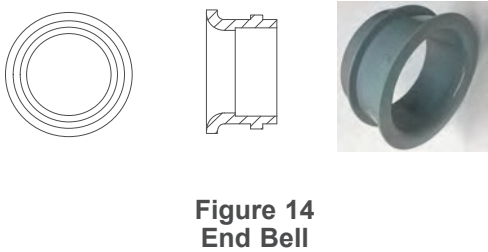


**Table 12 Material Codes for Rigid Conduit Caps and Cap Plugs**

Conduit Size (inches)	Material Codes	
	Rigid Cap	Cap Plug
2	360425	360440
3	360426	360441
4	360428	360443
5	360429	360444
6	360488	360494

**Table 13 Material Codes for End Bells**

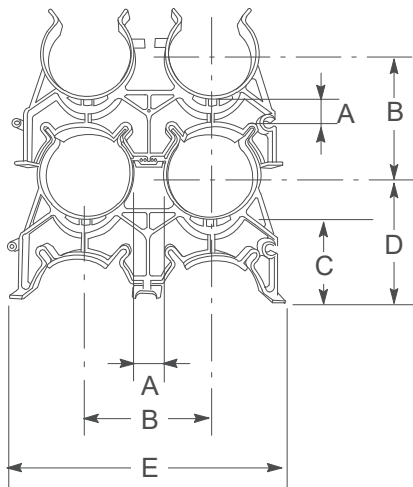
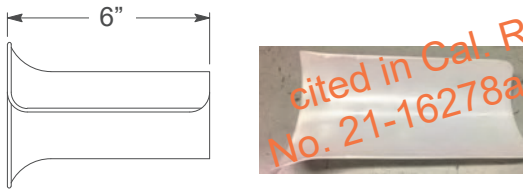
Conduit Size (inches)	Material Code
2	360420
3	360421
4	360423
5	360424
6	360487



**Table 14 Material Codes for Cable Protectors <sup>1</sup>**

Conduit Size (inches)	Material Code
2	382034
3	382045
4	
5	
6	

<sup>1</sup> Not for new installations; for replacement only.



**Table 15 Material Codes for Snap-N-Stack Combo Spacers <sup>1</sup>**

Conduit Size (inches)	Duct OD (inches)	Horizontal Duct Positions	Dimensions (inches)					Material Material Codes
			A	B	C	D	E	
3	3.500	2	2	5.5	3.63	5.38	11	360459
4	4.500	2	2	6.5	3.88	6.06	13	360460
5	5.563	2	2	7.56	4.38	7.25	15.12	360461
6	6.625	2	2	8.62	4.13	7.38	17.25	360491

<sup>1</sup> Cable spacers allow only for 2" separation between conduits. Cable spacers are used only where is required to route around existing obstructions. Thus, locations where cable spacers are needed are exempt from the requirement of maintaining 3" separation between 600 A distribution circuits.

Underground Conduits

PVC Conduit and Fittings (continued)

Table 16 Material Codes for Rigid PVC Schedule 40 Conduit Bends (sweeps)<sup>3</sup>

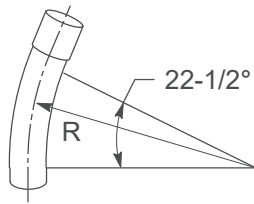


Figure 17  
22-1/2° PVC Conduit Bend

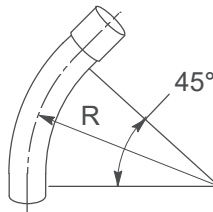


Figure 18  
45° PVC Conduit Bend

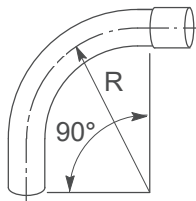


Figure 19  
90° PVC Conduit Bend

Conduit Size (inches)	Sweep		Material Code	
	Degree	Radius <sup>1</sup> (inches)		
2 <sup>2</sup>	11-1/4	24	360155	
		36	360156	
	22-1/2	24	360157	
		36	360158	
	45	24	360159	
		36	360160	
	90	24	360161	
		36	360162	
	3 <sup>2</sup>	11-1/4	36	360801
		22-1/2	36	360800
		45	36	360403
			24	360405
90		36	360328	
		24	360804	
4 <sup>2</sup>	11-1/4	36	360804	
		60	360805	
	22-1/2	36	360760	
		60	360761	
	45	36	360412	
		60	360413	
	90	36	360414	
		60	360415	
	5	11-1/4	36	360808
			60	360809
		22-1/2	36	360806
			60	360763
45		36	360416	
		60	360417	
90		36	360418	
		60	360419	
6		11-1/4	60	360811
		22-1/2	60	360765
	45	36	360485	
		60	360486	
	90	36	360483	
		60	360484	

*cited in Cal. Rest. Ass'n v. City of Berkeley  
No. 21-16278am archived December 27, 2023*

<sup>1</sup> For each conduit bend; first row shows minimum vertical radius, second row shows minimum horizontal radius.  
<sup>2</sup> For 2" and 3" primary conduits 90° degree bends, use 36" vertical radius. 24" vertical radius can be used with secondary and service conduits only.  
<sup>3</sup> See Notes 1 and 2 on Page 10.

### Underground Conduits

#### PVC Conduit and Fittings (continued)

Notes in reference to Table 16 on Page 9

1. A 36" may be allowed as the minimum horizontal radius when using 4" PVC conduits bends greater than 5° if field conditions make it not feasible to install 60" radius and if such field conditions are validated by PG&E inspectors.
2. Note 1 above does not apply to secondary service conduits installations. For secondary service conduits installations, 36" is the minimum horizontal radius for 4" conduit. See [Document 063927](#) and [Document 063928](#).

#### Large Radius Sweeps

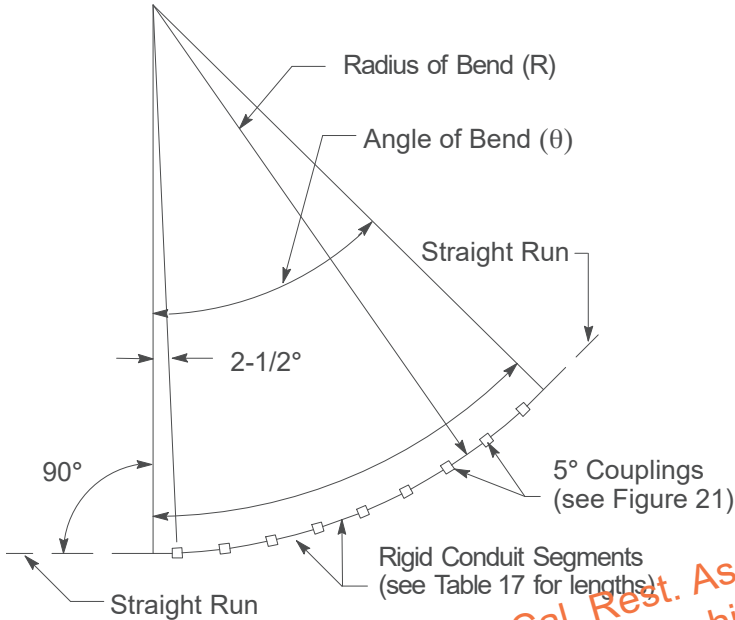


Figure 20  
Typical Application of 5° Couplings

Table 17 Length of Rigid PVC Conduit Segments

Approximate Radius of Bend (R)	Length of Rigid Conduit Segments (feet)
11' 6"	1
17' 3"	1.5
23' 0"	2
28' 9"	2.5
34' 6"	3
40' 3"	3.5
46' 0"	4
51' 9"	4.5
57' 6"	5
69' 0"	6
80' 6"	7
92' 0"	8

*cited in Cal. Rest. Ass'n v. City of Berkeley  
No. 21-16278am archived December 27, 2023*

#### Example

Radius Bend (R) = 60 Feet  
Angle of Bend (θ) = 45°

From Table 17 The nearest value to 60-foot radius is 57' 6".  
The length of conduit segments = 5 feet.

From Table 18 For a 45° angle bend:  
The number of 5° couplings required = 9.  
The number of conduit segments required = 8.

Table 18 Number of Couplings and Conduit Segments Required

Angle of Bend (θ)	Number of Couplings and Outside Diameter Conduit Segments Required	
	Coupling	Conduit
15°	3	2
30°	6	5
45°	9	8
60°	12	11
75°	15	14
90°	18	17

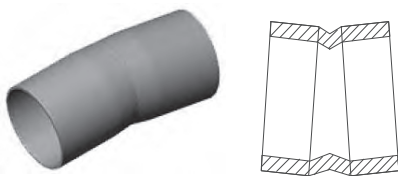


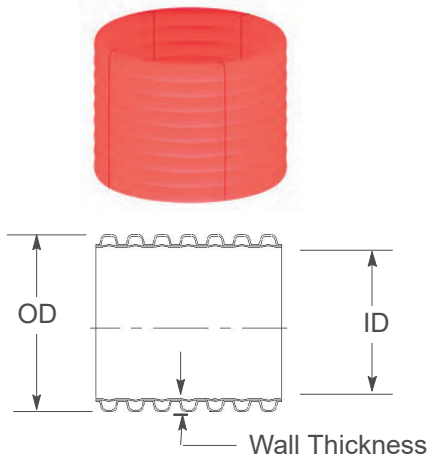
Figure 21  
5° Coupling

Table 19 Material Codes for PVC Schedule 40, 5 Degree Coupling

Coupling Size (inches)	Material Code
2	360154
3	360399
4	360400
5	360407
6	360495

Underground Conduits

Flexible (HDPE) Conduit and Fittings



**Figure 22**  
Corrugated Core Flex Conduit

**Table 20 Data and Material Codes for Corrugated Core Flex Conduit With Couplers (250' coil) <sup>1, 2, 3</sup>**

Conduit Size (inches)	Dimension (inches)			Material Code
	Outside Diameter	Inside Diameter	Wall Thickness	
2	2.375	2.050	.163	360095
3	3.500	2.950	.275	360096
4	4.750	3.975	.387	360097

- <sup>1</sup> Conduit can be used in areas minor soil settlement issues or for re-routes.
- <sup>2</sup> Inside wall is corrugated.
- <sup>3</sup> Minimum bending radius is 24 inches for all sizes.

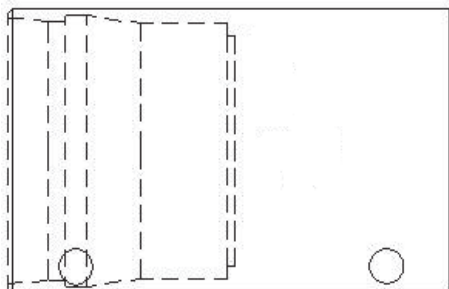


**Figure 23**  
Key-Lock™ Couplers

**Table 21 Data and Material Codes for Key-Lock™ Couplers <sup>1</sup>**

Conduit Size (inches)	Insertion Lengths (inches)	Material Code
2	2.725	360102
3	3.125	360103
4 <sup>2</sup>	2.875	360105

- <sup>1</sup> Kit has coupler, two locks and two gaskets.
- <sup>2</sup> Coupler to connect corrugated core flex to corrugated core flex.

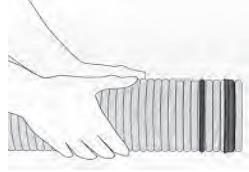


### Underground Conduits

#### Flexible (HDPE) Conduit and Fittings (continued)

##### Install the Key-Lock Coupler Following the Procedure Below

1. Make certain the elastomeric gasket is seated in the second corrugation on 4" conduit and the first corrugation on 6" conduit. Be sure the gasket is positioned as shown on Figure 24.



**Figure 24**  
**Key-Lock™ Couplers Gasket Position**

2. Use only a water-based lubricant. Apply the lubricant to the outside surface of the gasket. A light coating of lubricant should also be applied to the chamfered leading edge of the coupler as shown on Figure 25.



**Figure 25**  
**Key-Lock™ Couplers Lubricant Application**

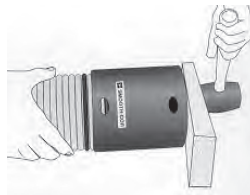
3. Insert the gasketed end of the Smooth-Cor® conduit into the coupler. Note the black home-mark, which is used to identify proper coupling as shown on Figure 26.

*cited in Cal. Post. Ass'n v. City of Berkeley  
No. 21-16278am archived December 27, 2023*



**Figure 26**  
**Key-Lock™ Couplers Insertion**

4. Use a mallet and wood block to seat the coupler until the home-mark is covered. Note that the small lock ring on the inside surface of the coupler snaps into a matching corrugation as shown on Figure 27.

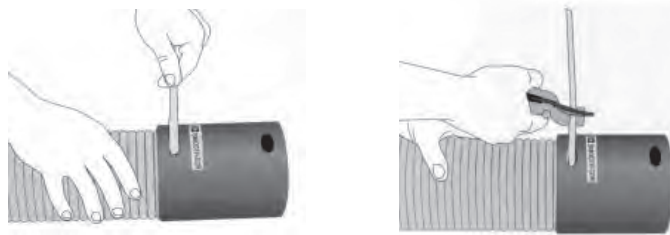


**Figure 27**  
**Key-Lock™ Couplers Locked in Place**

## Underground Conduits

**Flexible (HDPE) Conduit and Fittings (continued)**

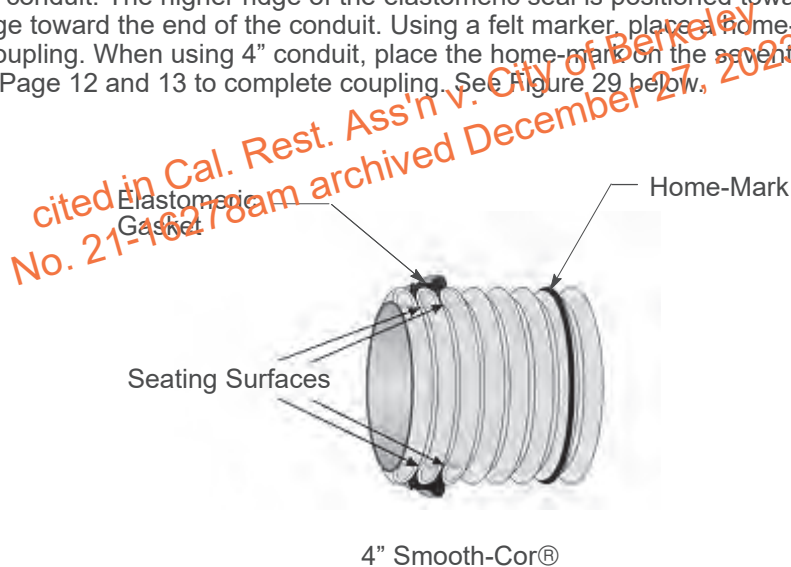
5. Insert the Key-Lock™ strip following the directional arrow into the pre-drilled hole in the coupler. Apply a small amount of lubricant to aid in the insertion. Push the Key-Lock™ strip (in the direction of the arrow on the label) around the entire circumference, locking the grooves in the conduit and coupler securely together. Trim the excess Key-Lock™ strip material from the coupler (optional). See Figure 28 below.



**Figure 28**  
**Key-Lock™ Couplers Strip Insertion**

Note: When cutting the Smooth-Cor® conduit in the field to a custom length, it necessary to follow the steps below:

1. Cut the conduit at the selected corrugation valley.
2. Place the gasket over the newly cut and cleaned end, making certain to seat the gasket on the second corrugation for 4" conduit. The higher ridge of the elastomeric seal is positioned toward the body of the conduit and the lower ridge toward the end of the conduit. Using a felt marker, place a home-mark on the conduit to achieve proper coupling. When using 4" conduit, place the home-mark on the seventh corrugation. Repeat steps 2-5 as shown on Page 12 and 13 to complete coupling. See Figure 29 below.



**Figure 29**  
**Key-Lock™ Couplers Cut at Customized Length**



### Underground Conduits

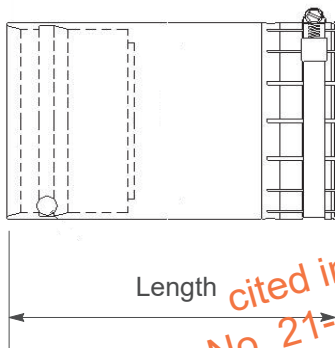
#### Flexible (HDPE) Conduit and Fittings (continued)



**Table 22 Data and Material Codes for Shurlock/Key-Lock™ (Adapter Smooth-Core-Shur-Lock Kit™ 1, 2)**

Conduit Size (inches)	Dimension (inches)	Material Code
	Length	
2	6.7	360106
3	6.63	360107
4	8.0	360108

- <sup>1</sup> Kit has adapter, one lock, and one gasket.
- <sup>2</sup> Adapter works connecting SC conduit to PVC and SC conduit to threaded steel conduit.



**Table 23 Required Rigid PVC stub out length <sup>1</sup>**

Conduit Size (inches)	PVC Stub Out (inches)
2	14.8
3	14.5
4	15
6	17.5

- <sup>1</sup> Stub out length needed to provide enough space for the adapter to connect rigid PVC to flexible conduit.

**Note**

1. The key-lock bell end adapters smooth-core bell are no longer commercially available. Before the end of the flexible conduit run, it is necessary to transition from the flexible conduit to PVC conduit by following the steps below.
  - A. Use appropriate size Shurlock/Key-Lock™ coupler listed in Table 22.
  - B. Use a straight section of at least 18 inches of appropriate size PVC conduit listed in Table 6 on Page 6.
  - C. Use appropriate size end bell for PVC conduit listed in Table 13 on Page 8.



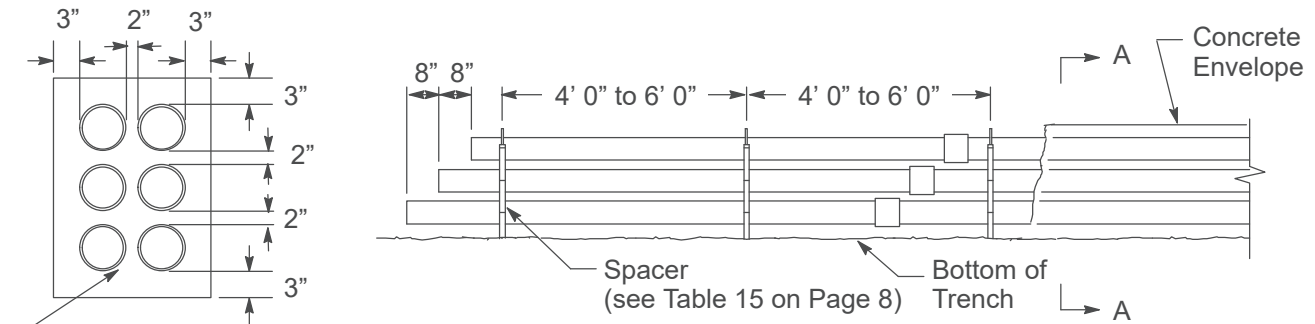
**Figure 31 Shur-Lock II Coupler**

**Table 24 Data and Material Codes for Shur-Lock II Coupler**

Conduit Size (inches)	Dimension (inches)	Material Code
	Length	
2	5.70	027241
3	10.75	027242
4	12.00	027243
5	14.25	027244
6	14.25	027256

Underground Conduits

Conduit Construction, Built-up Method



Plastic Conduit  
(see Table 6 on Page 6)  
Separation between conduits  
when using spacer. See  
Figure 16 on Page 8.

Section A-A

Figure 32  
Typical Straight Run Installation  
(6" conduit, 6-way shown)

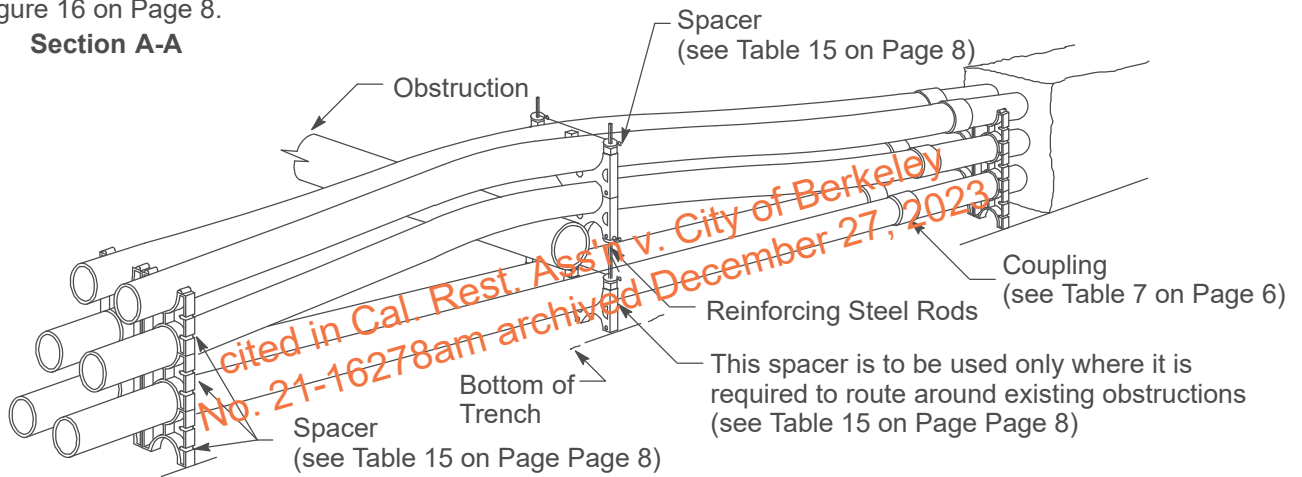


Figure 33  
Typical Perspective View of  
Installation Around Obstruction

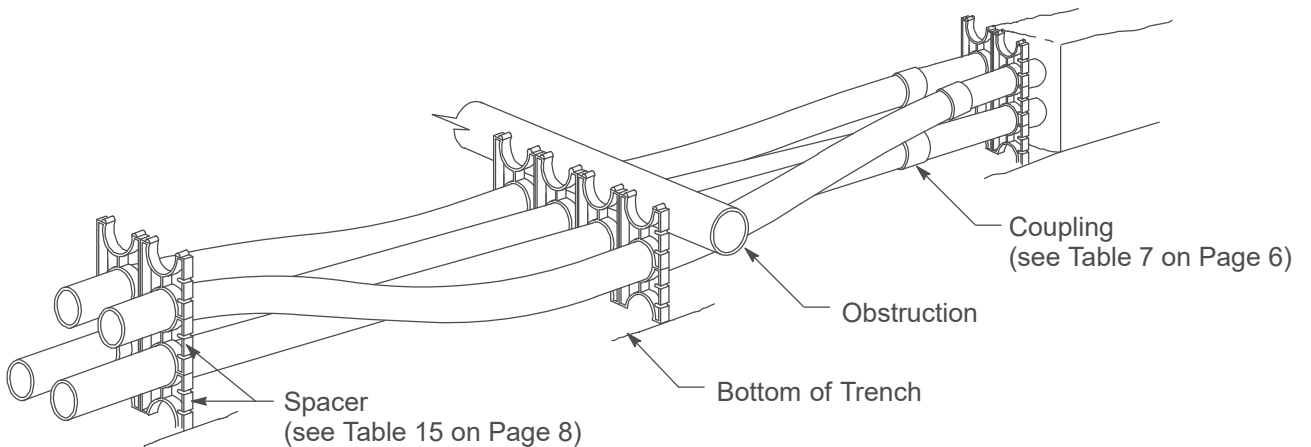


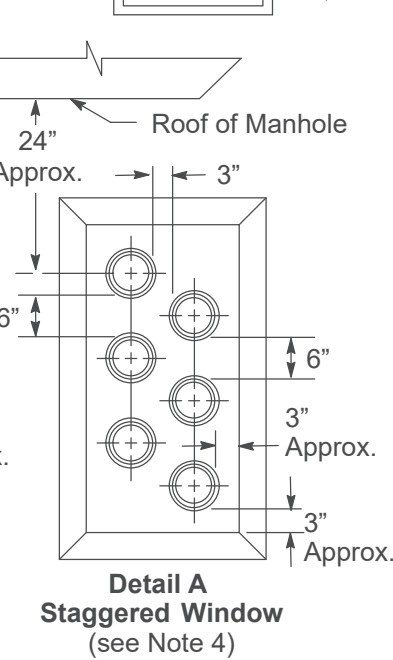
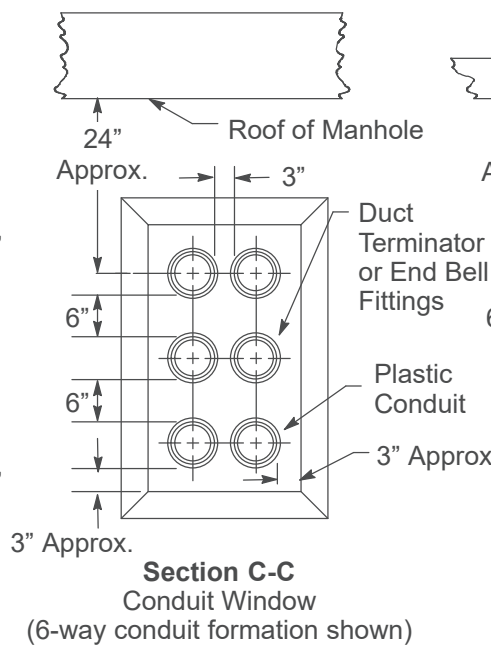
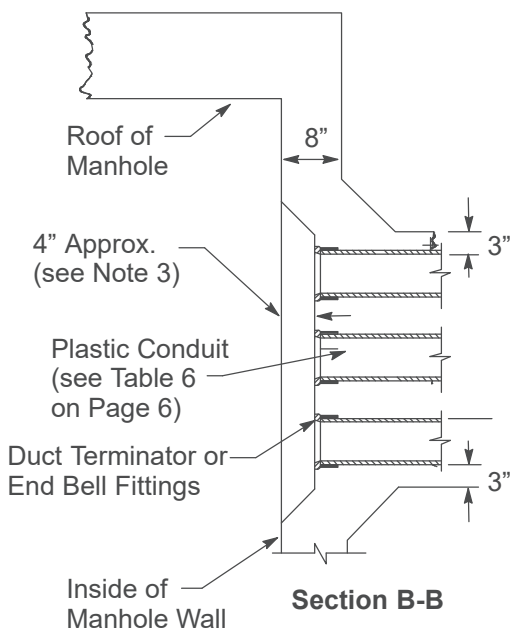
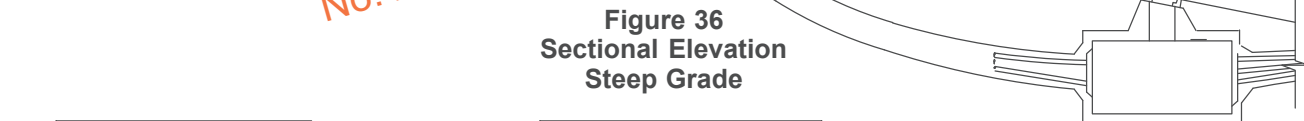
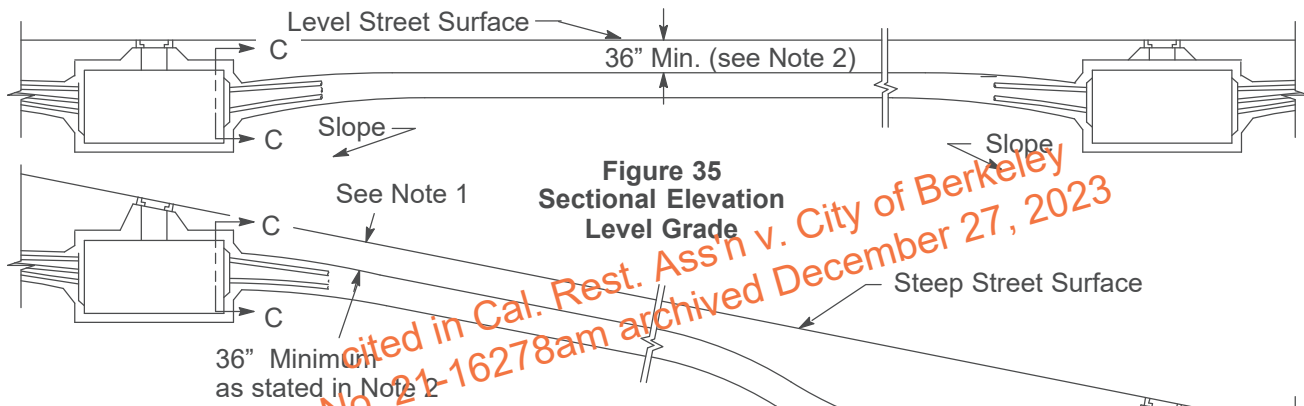
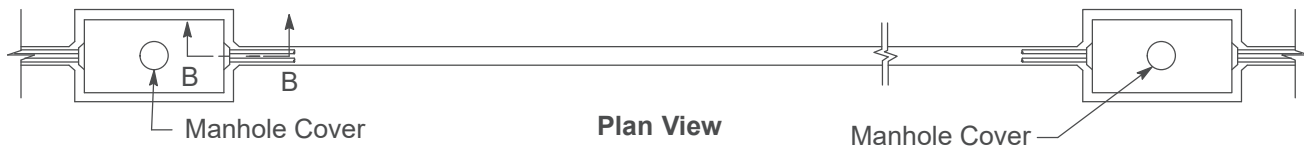
Figure 34  
Typical Perspective View of  
Installation Under Obstruction

## Underground Conduits

### Construction and Termination of Conduit Line into a Manhole or Vault

**Notes**

1. Slope the conduit sufficiently to provide adequate drainage. On level ground, slope the duct line from the center to each manhole.
2. Local city ordinances may require a minimum cover greater than PG&E's requirements of 24" for conduits containing circuits energized at 750 volts or less, and 36" for conduits containing circuits energized in excess of 750 volts. Depth may be reduced in either case if adequate mechanical protection – as defined in [Section 3.3.6 of the Greenbook](#)– is provided.
3. Where required, the depth of the conduit window may be increased. Where this is necessary, tie the conduit envelope concrete into the manhole reinforcing steel.
4. Vertical staggering of conduits at entrance shown in Detail A will assist in arranging for cable crossover if required.



Underground Conduits

Concrete Encasement Conduit Configuration Tables

Notes

1. For conduit lines two-way and larger, install #4 reinforcing bars in all four corners of the conduit envelope. Overlap bars 15 inches and install a minimum of 3 inches from the top or bottom and 1 inch from the side of the envelope.
2. Where the width of the trench is greater than the required width of the envelope, the horizontal spacing between conduits may be increased as long as 3-inch spacing between the conduit and the outside edge of the envelope is maintained.
3. Concrete: Normal Weight  
Aggregate, ASM, C33 Uniformly Graded  
Maximum Aggregate Size 3/4 inch type  
Minimum Compressive Strength:  $f'_c = 3,000$  pound-force per square inch (psi).

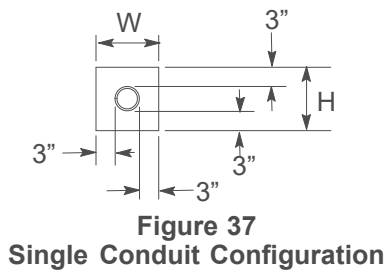


Table 25 Dimensions for Single Conduit Configurations

Conduit		Envelope Dim.		Concrete Reqd. Cubic Yards per 100 ft. <sup>1</sup>
Description	Size	W	H	
Single	2"	8-1/2"	8-1/2"	1.9
	3"	9-1/2"	9-1/2"	2.3
	4"	10-1/2"	10-1/2"	2.8
	5"	11-1/2"	11-1/2"	3.4
	6"	12-1/2"	12-1/2"	4.0

<sup>1</sup> Quantities may vary due to variations encountered in construction.

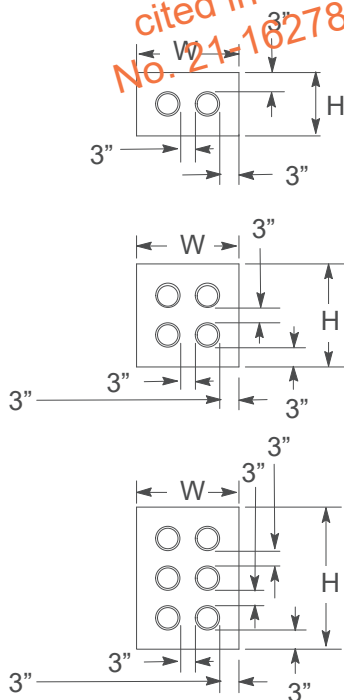


Table 26 Dimensions for Multiple Conduit Configurations

Conduit		Envelope Dim.		Concrete Reqd. Cubic Yards per 100 ft. <sup>1</sup>
Description	Size	W	H	
2-way	3"	16"	9-1/2"	3.9
	4"	18"	10-1/2"	4.9
	5"	20"	11-1/2"	5.9
	6"	22-1/2"	12-1/2"	7.2
4-way	4"	18"	18"	8.3
	5"	20"	20"	10.3
	6"	22-1/2"	22-1/2"	13.0
6-way	4"	18"	25-1/2"	11.8
	5"	20"	29"	15.0
	6"	22-1/2"	32"	18.5
8-way	4"	18"	33"	15.3
	5"	20"	37-1/2"	19.0
	6"	22-1/2"	41-1/2"	24.0

<sup>1</sup> Quantities may vary due to variations encountered in construction.

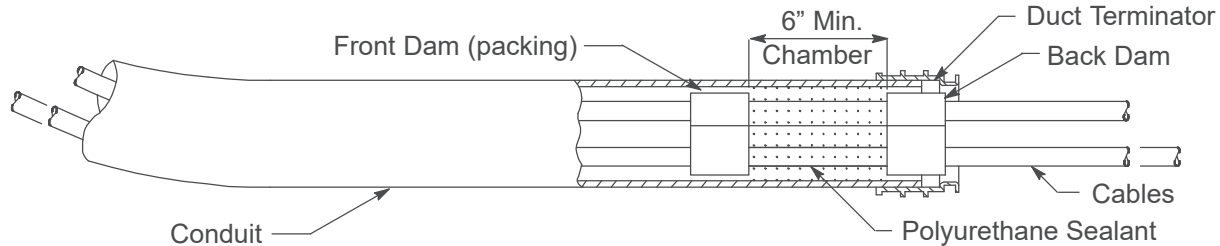
cited in Cal. Rest. Ass'n v. City of Berkeley  
No. 21-16278am archived December 27, 2023

## Underground Conduits

### Instructions for Sealing Conduit Using Foam

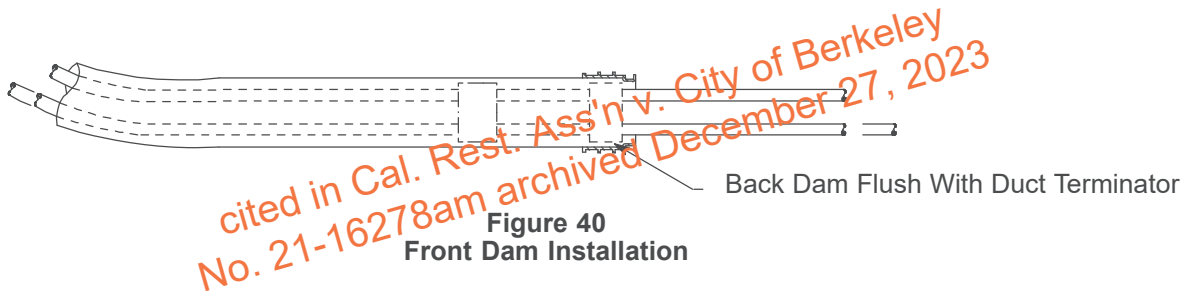
#### Notes

1. Within minutes, polyurethane foam expands to form a water and gas barrier that can be easily removed in the future.
2. Consult the manufacturer's instructions included in each kit.



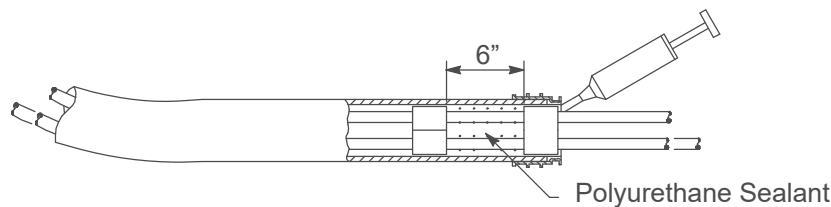
**Figure 39**  
**Details of a Polyurethane Seal**

- Step 1 Wipe off loose dirt and grime from cables.
- Step 2 Install front dam (packing). Wind a strip of packing around each cable. Push the dam approximately 6 inches to 8 inches into the conduit. Install the back dam in the same manner as the front dam, and push it into the conduit until the dam is flush with the duct terminator.



**Figure 40**  
**Front Dam Installation**

- Step 3 Insert the nozzle into the chamber between the dams and inject polyurethane.



**Figure 41**  
**Nozzle Application**

**Table 27 Material Codes for Polyurethane Conduit Seal Kits <sup>1</sup>**

Conduit Size	Material Code	Manufacturer	Catalog Number
2" Through 6"	019178	Dura-Line (Arnco) Hydro Seal	S-60-C6P
	490813	Polywater	FST-250KIT-PGE

<sup>1</sup> Kits have a 12 month shelf-life.

## Underground Conduits

**Instructions for Sealing Conduit Using RDSS****Notes**

1. Consult the manufacturer's instructions included in each kit.
2. Installation tool IT-16 is needed to install RDSS. This tool uses CO<sub>2</sub> cartridges. Both of these materials need to be ordered separately. See Figure 44 on Page 20 .
3. Select the appropriate RDSS size per Table 28.
4. When sealing three or more cables, the RDSS sealing clip listed on Table 34 must be used with the DRSS duct deal. One clip seals up to four cables.
5. Order RDSS as indicated in Table 29 on Page 20.
6. For additional reference, the link below provides an installation video. This video was developed by the manufacturer and may not reflect the use of the company required PPE. When performing this work, please be sure to use the appropriate PPE (i.e. long sleeves, hard hat, etc.) as required by PG&E. The video titled "RDSS – Rayflate Duct Seal System Installation and Removal" is posted in Microsoft Stream. Access Microsoft Stream at <https://web.microsoftstream.com/> from PG&E intranet.

**Table 28 RDSS Size Selection**

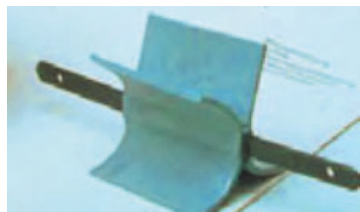
Normal Duct (Conduit) Size (Inches)	RDSS-45 Cable/Cable Bundle Diameter (Inches)	RDSS-60 Cable/Cable Bundle Diameter (Inches)	RDSS-75 Cable/Cable Bundle Diameter (Inches)	RDSS-100 Cable/Cable Bundle Diameter (Inches)	RDSS-125 Cable/Cable Bundle Diameter (Inches)	RDSS-150 Cable/Cable Bundle Diameter (Inches)
1-1/2	0-1.25					
2		0-1.50	0-1.00			
3				0-1.00		
4				0-3.25	0-2.75	
5 <sup>2</sup>					0-2.75-4.5	2.50-4.24
6 <sup>2</sup>						2.50-5.50
RDSS Clip Size		75	75	100	125	150

<sup>1</sup> One RDSS clip per RDSS seal is included in the kit.

<sup>2</sup> For 5" and 6" ducts with cable bundle diameters less than listed on this table or empty; an RDSS-AT/AP-150 device must be used along with RDSS. RDSS-AT/AP-150 must be ordered separately. See Figure 44 on Page 20.



**Figure 42**  
RDSS Seal and Clip



**Figure 43**  
AT/AP-150 Device

### Underground Conduits

#### Instructions for Sealing Conduit Using RDSS (continued)



Figure 44  
IT-16 Installation Tool and CO<sub>2</sub> Cartridges



Figure 45  
RDSS Installed

Table 29 Material Material Codes for RDSS Kits and Installation Tool

Item	Material Description	Material Code
1	RDSS-45-PG&E	360213
2	RDSS-60-PG&E	360214
3	RDSS-75-PG&E	360215
4	RDSS-100-PG&E	360216
5	RDSS-125-PG&E	360217
6	RDSS-150-PG&E	360218
7	RDSS-AT/AP-150 Device	360219
8	RDSS-IT-16 Tool	360220
9	Compressed CO <sub>2</sub> Gas Cylinders	360221

<sup>1</sup> Installation tool re-usable. Unless damaged, only need to order once.



<sup>2</sup> Only these types of cylinders are compatible with this tool.

#### Revision Notes

Revision 20 has the following changes:

1. Added Note 1C(1) –1C(3) Page 1.
2. Modified Notes 16 on Page 2 and Note 19 on Page 3.
3. Added compaction requirements to Note 23 on Page 3.
4. Moved, revised and added additional trench requirements from this Document to Document 038193.
5. Revised minimum socket dept information in Table 7 on Page 6.
6. Added new Figure 31 and Table 24 to show information of Shur-Lock II Couplers on Page 14.

Prepared by: ABB1

	<b>LANDSCAPE SCREEN FOR PAD-MOUNTED TRANSFORMERS</b>	<b>063422</b>
	<b>Asset: Type:</b> Electric Distribution <b>Issued By:</b> M. L. Thabault (MLTC) 	<b>Function:</b> Design and Construction <b>Date:</b> 08-15-17
<b>Rev. #04:</b> This document replaces PG&E Document 063422, Rev. #03. For a description of the changes, see Page 12.		

**Purpose and Scope**

This document provides a variety of landscape design ideas that may be used by the applicant to screen pad-mounted transformers.

Pad-mounted transformers are much less costly to install and maintain than subsurface transformers. While any landscaping, retaining walls, decorative walls, etc. may be installed or maintained by the applicant, landscape screening is encouraged as it helps improve the overall appearance and acceptance of pad-mounted transformers.

**General Information**

1. This document is intended to illustrate a variety of design concepts. They may be modified to fit a particular need or site condition.
2. The figures in this document are illustrative designs and are not intended to be construction or working drawings. Materials, quantities, and construction methods will have to be determined by the installer to meet the requirements of the particular site.
3. The addition of suitable plants to these basic designs will enhance the overall screening effect.
4. The designs illustrate screening single-phase transformers, but the same concepts may also be applied to screening three-phase pad-mounted transformers.
5. The decorative walls, fences, etc., depicted in this document are not substitutes for any required barrier posts, fire walls, etc., that may be required by [Document 051122](#).
6. The applicant may not paint the exterior of the transformer a different color.

**Plant Matrices**

7. See Pages 7 through 12 for a plant matrix that identifies plant species suitable for screening transformers within the different climatic areas of each division.

**Clearances**

8. 8-foot minimum (measured from the edge of the pad) in front of all equipment doors to provide room to operate with hot sticks and to replace the equipment.
9. A clearance of 2 feet is required from the transformer pad to walls, fences, etc., as depicted in this document. The clearance may be reduced to 1 foot if the height of the wall does not exceed 2 feet and if the wall thickness does not exceed 1 foot (i.e., planter box). See [Document 051122](#) for the clearances to building walls.
10. Gates and doors may be placed with minimal clearance in front of the transformers if the required 8-foot clearance is available with the doors or gates open.

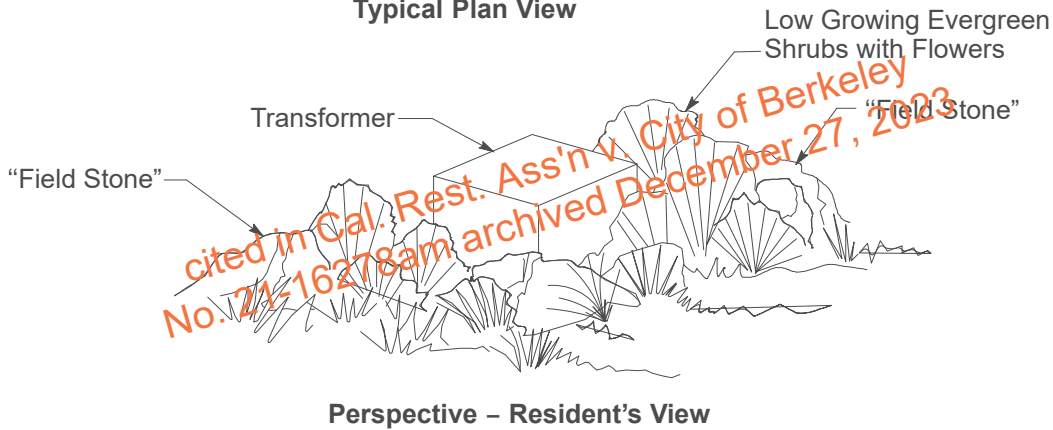
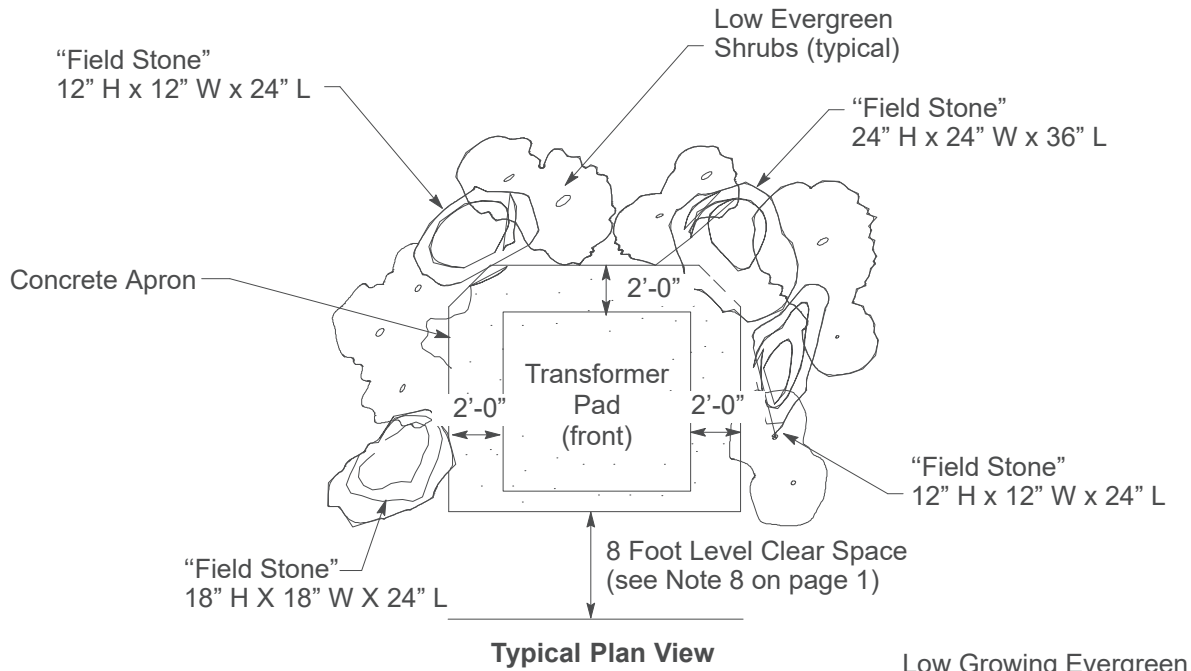
**References**

References	Location	Document
<a href="#">Location, Clearances, and Mechanical Protection Details for Pad-Mounted and Subsurface Equipment</a> .....	<a href="#">UG-1: General/Greenbook</a> .....	<a href="#">051122</a>



### Landscape Screen for Pad-Mounted Transformers

#### Landscape Screen



**Figure 1  
Landscape Screen**

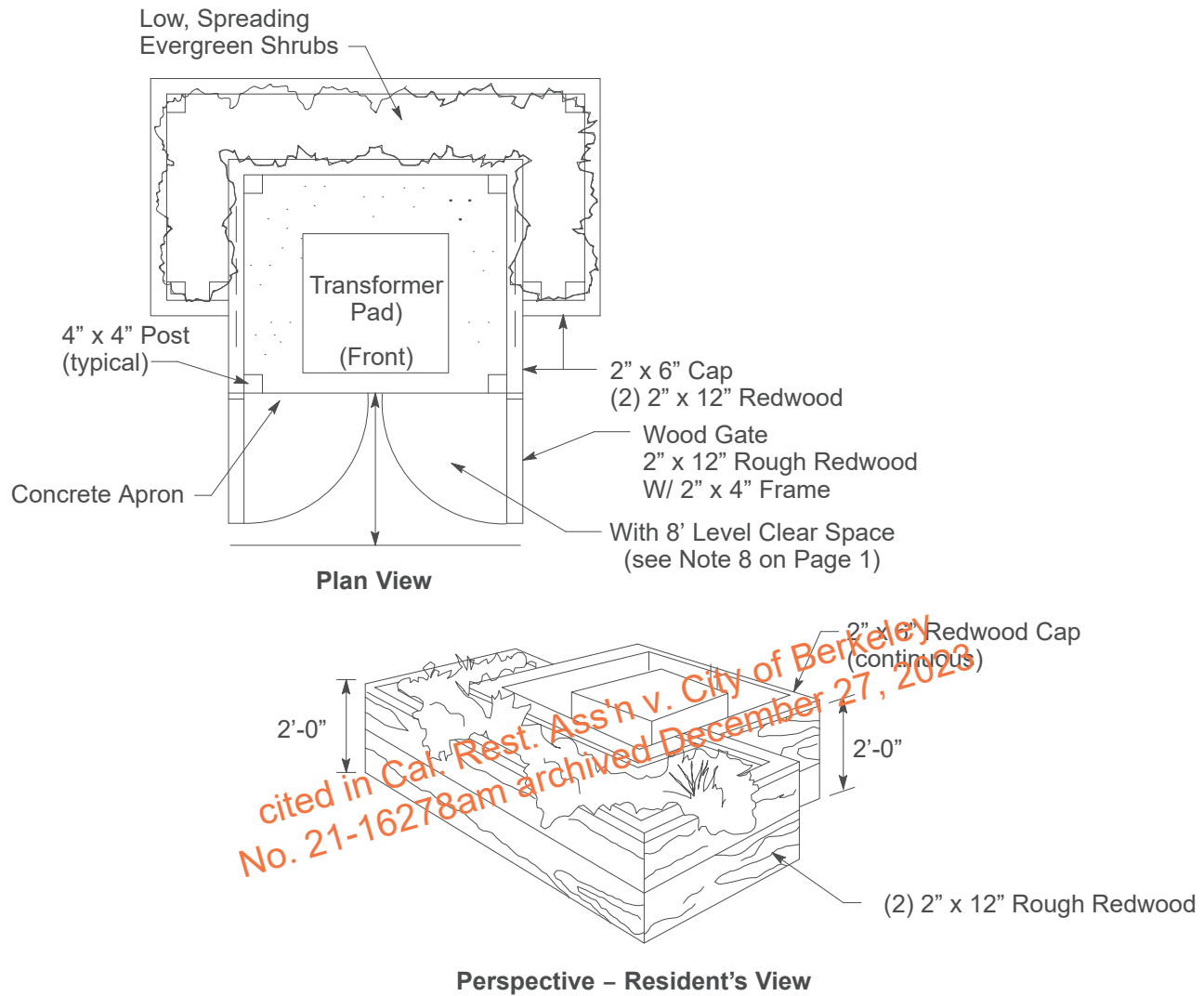
**Table 1 List of Material for Landscape Screen**

Quantity	Description
4	“Sonoma Field Stones”
10-12	Low Evergreen Shrubs (5 gallon size)
1/2 Cubic Yard	Concrete (4” deep, broom finish) <sup>1</sup>
1/2 Cubic Yard	Gravel Sub Base (4” deep) <sup>1</sup>

<sup>1</sup> Excluding transformer pad.

**Landscape Screen for Pad-Mounted Transformers**

**Planter Wall Screen**



**Figure 2  
Planter Wall Screen**

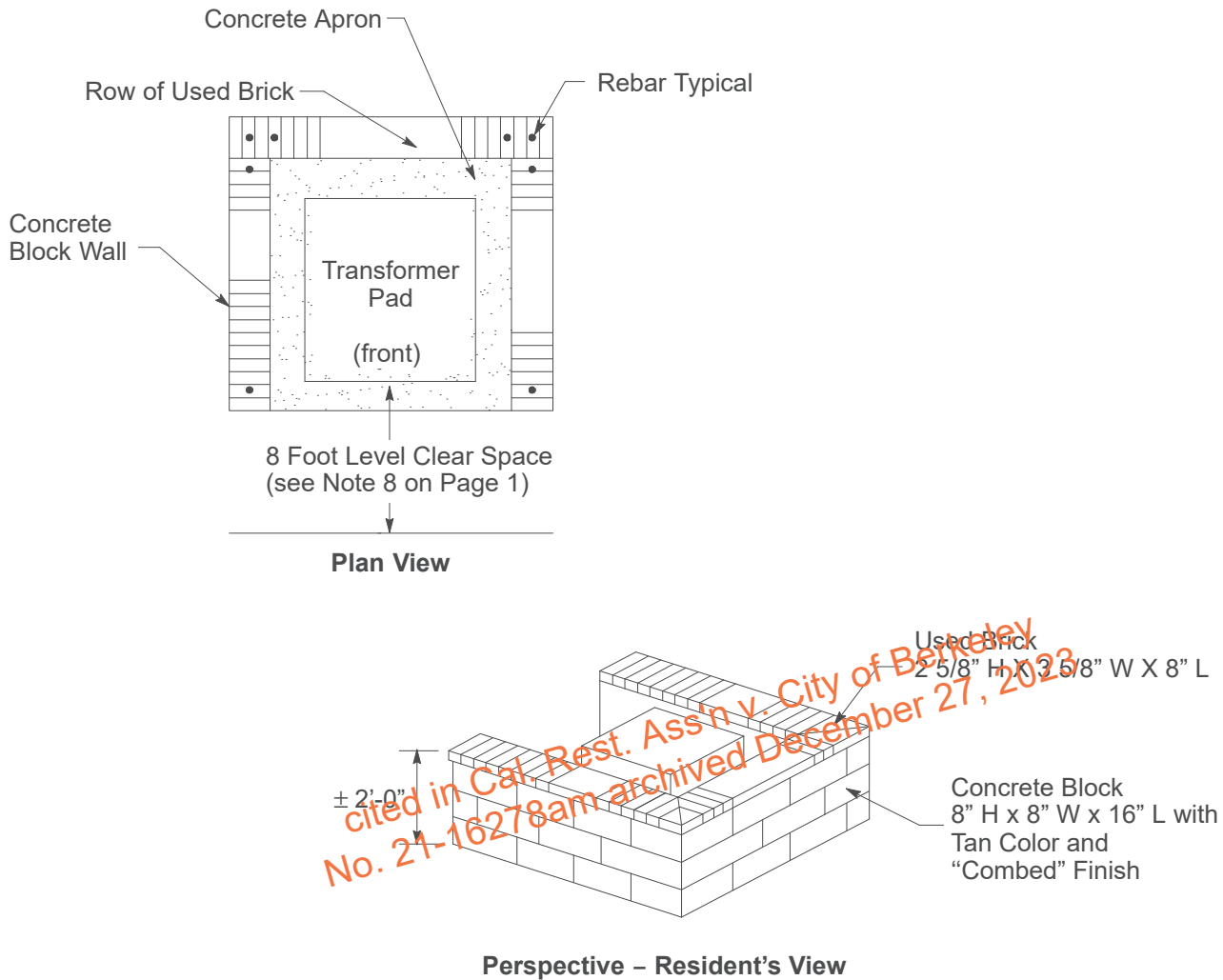
**Table 2 List of Materials for Planter Wall Screen**

Quantity	Description
6	2" x 12" Rough Redwood (12 feet long)
4	2" x 12" Rough Redwood (8 feet long)
3	2" x 6" Rough Redwood (12 feet long)
5	4" x 4" Rough Redwood (8 feet long)
1/2 Cubic Yard	Concrete (broom finish) <sup>1</sup>
1/2 Cubic Yard	Gravel Sub Base (4" deep) <sup>1</sup>
10	Low Evergreen Shrubs ( 5 gallon size)
4	2" x 4" Rough Redwood (8 feet long)
1	2" x 6" Rough Redwood (8 feet long)

<sup>1</sup> Excluding transformer pad.

### Landscape Screen for Pad-Mounted Transformers

#### Wall for Screening



*cited in Cal. Rest. Ass'n v. City of Berkeley No. 21-16278am archived December 27, 2023*

**Figure 3**  
**Wall for Screening**

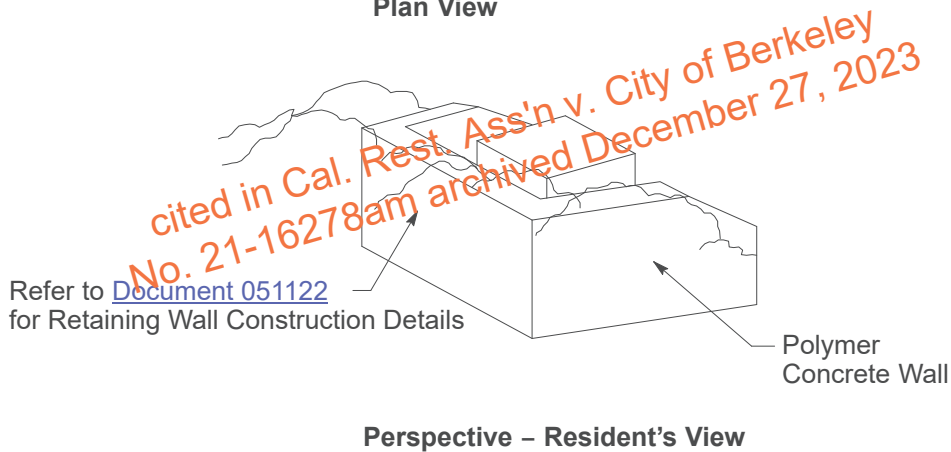
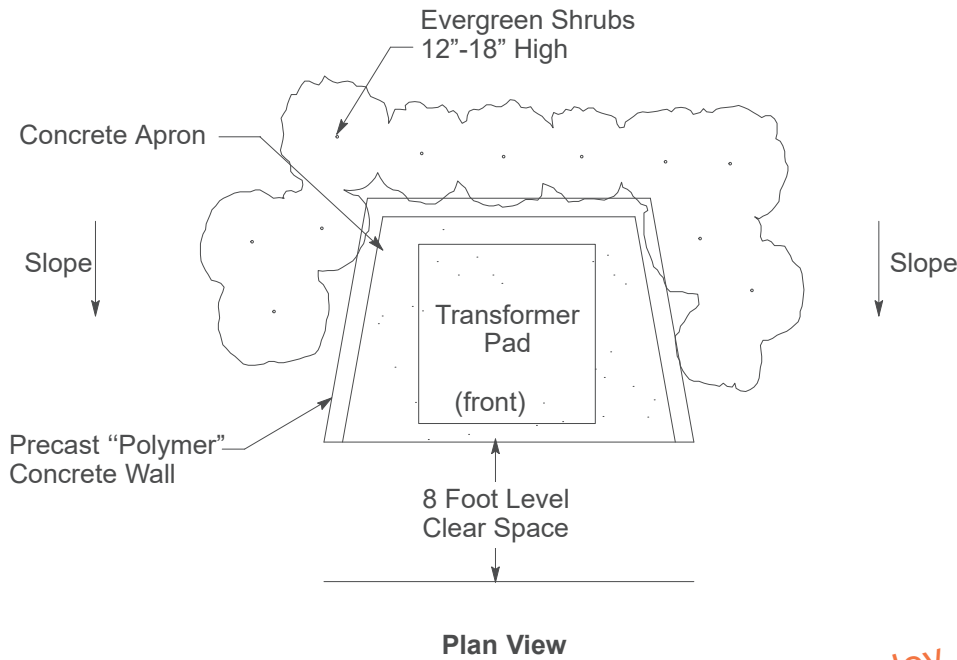
**Table 3 List of Materials for Wall for Screening**

Quantity	Description
80	Used Bricks
-	Mortar
52	Concrete Blocks (8" W x 8" H x 16" L)
1/2 Cubic Yard	Concrete (4" deep, broom finish) <sup>1</sup>
1/2 Cubic Yard	Gravel Sub Base (4" deep) <sup>1</sup>
-	1/2" x 2' Rebar for Cells at Block Corners and Edges (minimum of 8 pieces)
-	Grout Fill for Block Corners and Edges

<sup>1</sup> Excluding transformer pad.

**Landscape Screen for Pad-Mounted Transformers**

**Retaining Wall**



**Figure 4  
Retaining Wall**

**Table 4 List of Materials for Retaining Wall**

Quantity	Description
12-14	Low, Evergreen Shrubs (5 gallon size)
19 LF	2' Polymer Concrete Wall
1/2 Cubic Yard	Concrete (4" deep, broom finish) <sup>1</sup>
1/2 Cubic Yard	Gravel Sub Base (4" deep) <sup>1</sup>

<sup>1</sup> Excluding transformer pad.

### Landscape Screen for Pad-Mounted Transformers

#### Pole and Landscape Screen

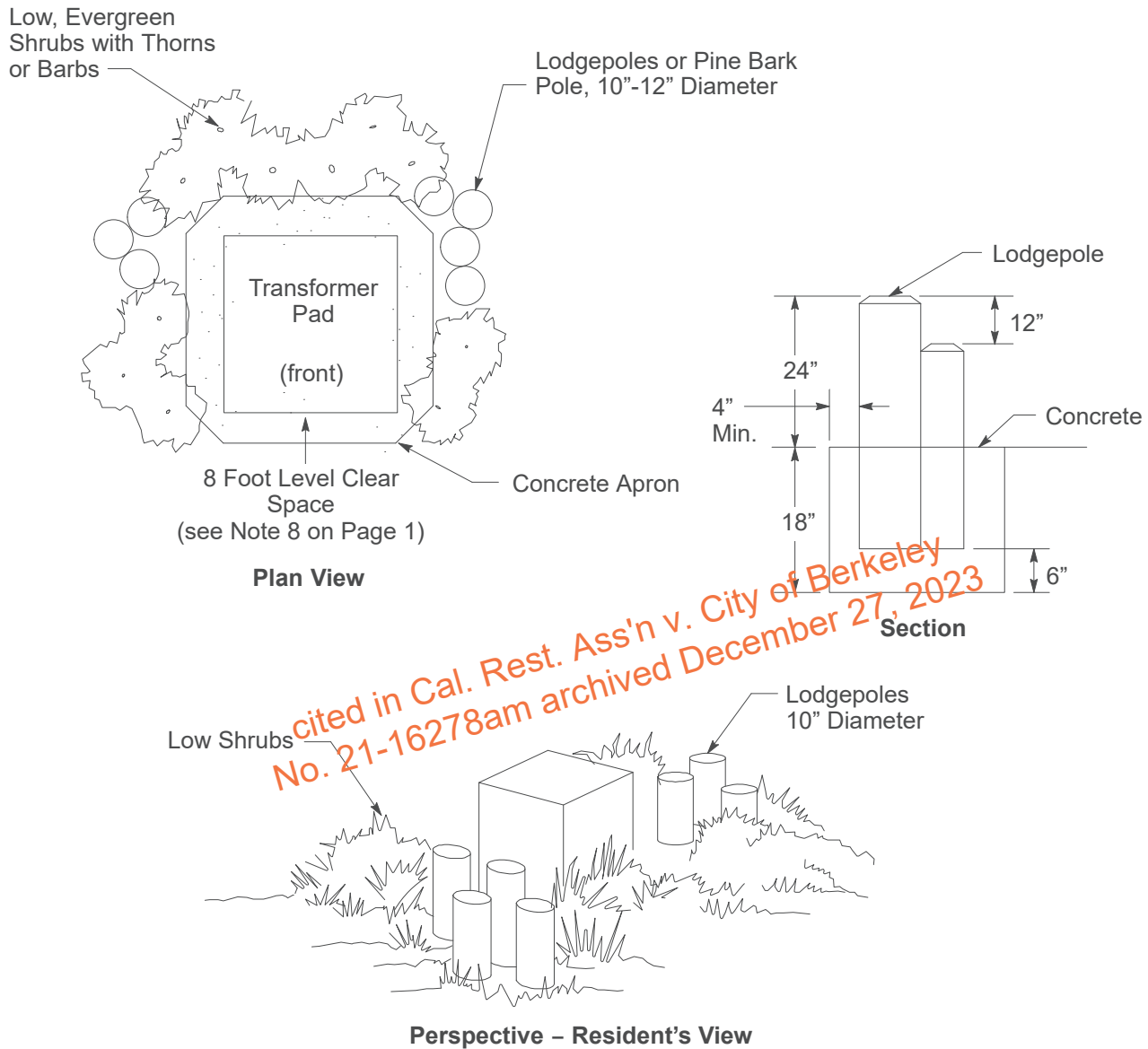


Figure 5 Pole and Landscape Screen

Table 5 List of Materials

Quantity	Description
7	10" Diameter Lodgepoles (3'-6" long)
3	10" Diameter Lodgepoles (3'-10" long)
12-14	Low Evergreen Shrubs (5 gallon size)
1/2 Cubic Yard	Concrete (4" deep, broom finish) <sup>1</sup>
1/2 Cubic Yard	Gravel Sub Base (4" deep) <sup>1</sup>

<sup>1</sup> Excluding transformer pad

## Landscape Screen for Pad-Mounted Transformers

### **Plant Matrix for Stockton, Yosemite, Fresno, and Kern Divisions**

#### Notes

1. All shrubs are evergreen plants not over 5 feet at maturity.
2. All shrubs should be planted at a minimum 5 gallon size.
3. Refer to the climate zone map in the *Sunset New Western Garden Book* for the climate zone in your area.

Plants (shrubs)	Climatic Zones				
	Zone 1	Zone 7	Zone 8	Zone 9	Zone 14
	Cold Climate, High Elevation, Snow All Year, Frost All Year, High Mountain, Area	Warm Climate, Hot Summer, Mild Winters, Low Elevations, Foothill Area	Warm Climate, Cold-Air Basins In Winter, Low Elevations, Hot, Dry Summers, Cool Winter	Hot Climate, Within Thermal Belt, Warmer and Higher Elevations than Zone 8, Foothill Areas	Warm Climate, Low Elevation, Hot and Dry Summers, Mainly Inland Valley Areas
Arctostaphylos "Hookeri" (Monterey Manzanita)	-	X	-	-	X
Arctostaphylos "Emerald Carpet" (Manzanita)	-	X	-	-	X
Arctostaphylos "Uva Ursi" (Bearberry)	-	X	-	-	X
Caenothus G.H. "Yankee Point" (Yankee Point Ceanothus)	-	X	-	-	X
Nandina Domestica (Heavenly Bamboo)	-	X	X	X	X
Agapanthus Orientalis (Lily-of-the-Nile)	-	X	X	X	X
Santolina Chamaecyparissus (Lavender Cotton)	X	X	X	X	X
Cistus Hybridus (White Rockrose)	-	X	X	X	-
Cistus Purpureus (Purple Rockrose)	-	X	X	X	-
Raphiolepis l. "Coates Crimson" (Indian Hawthorn)	-	-	X	X	X
Raphiolepis l. "Enchantress" (Indian Hawthorn)	-	-	X	X	X
Eriophyllum Confertiflorum (Yellow Yarrow)	X	X	X	X	X
Juniperus Conferta (Shore Juniper)	X	X	X	X	X
Rosemarinus Officinalis (Creeping Rosemary)	-	-	X	X	X

cited in Cal. Rest. Ass'n v. City of Berkeley  
No. 21-16278am archived December 27, 2023

## Landscape Screen for Pad-Mounted Transformers

### ***Plant Matrix for San Francisco, Peninsula, and DeAnza Divisions***

#### **Notes**

1. All shrubs are evergreen plants not over 5 feet at maturity.
2. All shrubs should be planted at a minimum 5 gallon size.
3. Refer to the climate zone map in the *Sunset New Western Garden Book* for the climate zone in your area.

Plants (shrubs)	Climatic Zones			
	Zone 14	Zone 15	Zone 16	Zone 17
	Warm Climate, Low Elevation, Hot and Dry Summers, Mainly Inland Valley Areas	Mild Climate, Coastal Influence, Cool-Air Basins in Coast Mountain Areas	Mild Climate, Coastal Influence, Within the Thermal Belt, Coastal Mountain Areas	Coastal Climate, Cool Winters and Hot Summers, Coastal Plain and Bay Shoreline
Senecio Cineraria (Dusty Miller)	X	X	X	X
Arctostaphylos "Hookeri" (Monterey Manzanita)	X	X	X	X
Caenothus G.H. "Yankee Point" (Yankee Point Ceanothus)	X	X	X	X
Cistus Hybridus (White Rockrose)	-		X	X
Cistus Purpureus (Purple Rockrose)			X	X
Santolina Chamaecyparissus (Lavender Cotton)	X	X	X	X
Raphiolepis I. "Coates Crimson" (Indian Hawthorn)	X	X	X	X
Raphiolepis I. "Enchantress" (Indian Hawthorn)	X	X	X	X
Pinus Mugo Mughos (Dwarf Forms)	X	X	X	X
Eriophyllum Confertiflorum (Yellow Yarrow)	X	X	X	X
Juniperus Conferta (Shore Juniper)	X	X	X	X
Rosemarinus Officinalus (Creeping Rosemary)	X	X	X	X
Cotoneaster Horizontalis (Rock Cotoneaster)	X	X	X	X
Nandina Domestica (Heavenly Bamboo)	X	X	X	X
Agapanthus Orientalis (Lily-of-the-Nile)	X	X	X	X

cited in Cal. Rest. Ass'n v. City of Berkeley  
No. 21-16278am archived December 27, 2023

## Landscape Screen for Pad-Mounted Transformers

### **Plant Matrix for San Jose, Central Coast, and Los Padres Divisions**

#### Notes

1. All shrubs are evergreen plants not over 5 feet at maturity.
2. All shrubs should be planted at a minimum 5 gallon size.
3. Refer to the climate zone map in the *Sunset New Western Garden Book* for the climate zone in your area.

Plants (shrubs)	Climatic Zones				
	Zone 7	Zone 14	Zone 15	Zone 16	Zone 17
	Warm Climate, Hot Summer, Mild Winters, Low Elevations, Foothill Area	Warm Climate, Low Elevation, Hot and Dry Summers, Mainly Inland Valley Areas	Mild Climate, Coastal Influence, Cool-Air Basins in Coastal Mountain Areas	Mild Climate, Coastal Influence Within the Thermal Belt, Coastal Mountain Areas	Coastal Climate, Cool Winters and Hot Summers, Coastal Plain and Bay Shoreline
Senecio Cineraria (Dusty Miller)	X	X	X	X	X
Arctostaphylos "Uva Ursi" (Bearberry)	X	X	X	X	X
Arctostaphylos "Hookeri" (Monterey Manzanita)	X	X	X	X	X
Arctostaphylos "Emerald Carpet" (Manzanita)	X	X	X	X	X
Cistus Hybridus (White Rockrose)	X	-	-	X	X
Cistus Purpureus (Purple Rockrose)	X	-	-	X	X
Santolina Chamaecyparissus (Lavender Cotton)	X	X	X	X	X
Raphiolepis l. "Coates Crimson" (Indian Hawthorn)	-	-	-	X	X
Pinus Mugo Mughos (Dwarf Forms)	X	X	X	X	X
Eriophyllum Confertiflorum (Yellow Yarrow)	X	X	X	X	X
Juniperus Conferta (Shore Juniper)	X	X	X	X	X
Rosemarinus Officinalus (Creeping Rosemary)	X	X	X	X	X
Cotoneaster Horizontalis (Rock Cotoneaster)	X	X	X	X	X
Nandina Domestica (Heavenly Bamboo)	X	X	X	X	X
Agapanthus Orientalis (Lily-of-the-Nile)	X	X	X	X	-

cited in Cal. Rest. Ass'n v. City of Berkeley  
No. 21-16278am archived December 27, 2023



### Landscape Screen for Pad-Mounted Transformers

## Plant Matrix for North Valley, Sierra, and Sacramento Divisions

### Notes

1. All shrubs are evergreen plants not over 5 feet at maturity.
2. All shrubs should be planted at a minimum 5 gallon size.
3. Refer to the climate zone map in the *Sunset New Western Garden Book* for the climate zone in your area.

Plants (shrubs)	Climatic Zones					
	Zone 1	Zone 2	Zone 7	Zone 8	Zone 9	Zone 14
	Cold Climate, High Elevation, Snow All Year, Frost All Year, High Mountain Area	Cold Climate, Snow and Frost 50% of the Year, Mountain Areas	Warm Climate, Hot Summer, Mild Winters, Low Elevations, Foothill Area	Warm Climate, Cold Air Basins in Winter, Low Elevations, Hot, Dry Summers, Cool Winter	Hot Climate Within the Thermal Belt, Warmer and Higher Elevations than Zone 8, Foothill Areas	Warm Climate, Low Elevation, Hot and Dry Summers, Mainly Inland Valley Areas
Senecio Cineraria (Dusty Miller)	-	-	X	-	-	X
Arctostaphylos "Hookeri" (Monterey Manzanita)	-	-	X			X
Arctostaphylos "Emerald Carpet" (Manzanita)	-			-	-	X
Euryoes Pectinatus (Desert Daisy)	-	-	-	-	-	X
Juniperus Conferta (Shore Juniper)	X	X	X	X	X	X
Santolina Chamaecyparissus (Lavender Cotton)	X	X	X	X	X	X
Cistus Hybridus (White Rockrose)	-	-	X	-	X	X
Cistus Purpureus (Purple Rockrose)	-	-	X	-	X	X
Eriophyllum Confertiflorum (Yellow Yarrow)	X	X	X	X	X	X
Agapanthus Orientalia (Lily-of-the-Nile)	-	-	X	X	X	X

cited in Cal. Rest. Ass'n v. City of Berkeley  
 No. 21-16278am archived December 27, 2023

## Landscape Screen for Pad-Mounted Transformers

### ***Plant Matrix for Diablo, Mission, and East Bay Divisions***

#### **Notes**

1. All shrubs are evergreen plants not over 5 feet at maturity.
2. All shrubs should be planted at a minimum 5 gallon size.
3. Refer to the climate zone map in the *Sunset New Western Garden Book* for the climate zone in your area.

Plants (shrubs)	Climatic Zones				
	Zone 7	Zone 14	Zone 15	Zone 16	Zone 17
	Warm Climate, Hot Summer, Mild Winters, Low Elevations, Foothill Area	Warm Climate, Low Elevation, Hot and Dry Summers, Mainly Inland Valley Areas	Mild Climate, Coastal Influence, Cool-Air Basins in Coastal Mountain Areas	Mild Climate, Coastal Influence Within the Thermal Belt, Coastal Mountain Areas	Coastal Climate, Cool Winters and Hot Summers, Coastal Plain and Bay Shoreline
Senecio Cineraria (Dusty Miller)	-	X	X	X	X
Arctostaphylos "Hookeri" (Monterey Manzanita)	X	X	X	X	X
Euryops Pectinatus (Desert Daisy)	-	X	X	X	X
Cistus Hybridus (White Rockrose)	X	-	X	X	X
Cistus Purpureus (Purple Rockrose)	X	-	-	X	X
Santolina Chamaecyparissus (Lavender Cotton)	X	X	X	X	X
Raphiolepis I. "Coates Crimson" (Indian Hawthorn)	-	X	X	X	X
Raphiolepis I. "Enchantress" (Indian Hawthorn)	-	X	X	X	X
Pinus Mugo Mughos (Dwarf Forms)	X	X	X	X	X
Ceanothus G.H. "Yankee Point" (Yankee Point Ceanothus)	X	X	X	X	X
Juniperus Conferta (Shore Juniper)	X	X	X	X	X
Cotoneaster Horizontalis (Rock Cotoneaster)	X	X	X	X	X
Nandina Domestica (Heavenly Bamboo)	X	X	X	X	X
Agapanthus Orientalis (Lily-of-the-Nile)	X	X	X	X	X

cited in Cal. Rest. Ass'n v. City of Berkeley  
No. 21-16278am archived December 27, 2023

## Landscape Screen for Pad-Mounted Transformers

### ***Plant Matrix for North Coast, and North Bay Divisions***

#### **Notes**

1. All shrubs are evergreen plants not over 5 feet at maturity.
2. All shrubs should be planted at a minimum 5 gallon size.
3. Refer to the climate zone map in the *Sunset New Western Garden Book* for the climate zone in your area.

Plants (shrubs)	Climatic Zones						
	Zone 1	Zone 2	Zone 7	Zone 14	Zone 15	Zone 16	Zone 17
	Cold Climate, High Elev. and Snow All Year, Frost All Year, High Mountain Areas	Cold Climate, Snow and Frost 50% of the Year, Mountain Areas	Warm Climate, Hot Summers, Mild Winters, Low Elevations, Foothill Areas	Warm Climate, Low Elevation, Hot and Dry Summers, Mainly Inland Valley Areas	Mild Climate, Coastal Influence, Cool-air Basins in Coast Mountain Areas	Mild Climate, Coastal Influence Within the Thermal Belt, Coastal Mountain Areas	Coastal Climate, Cool Winters and Hot Summers, Coastal Plain and Bay Shoreline
Senecio Cineraria (Dusty Miller)	-	-	X	X	X	X	X
Arctostaphylos "Hooker" (Monterey Manzanita)	-	-	X	X	X	X	X
Arctostaphylos "Emerald Carpet" (Manzanita)	-	-	X	X	X	X	X
Ceanothus G.H. "Yankee Point" (Yankee Pt. Ceanothus)	-	-	X	X	X	X	X
Euryops Pectinatus (Desert Daisy)	-	-	-	X	X	X	X
Juniperus Conferta (Shore Juniper)	X	X	X	X	X	X	X
Santolina Chamaecyparissus (Lavender Cotton)	X	X	X	X	X	X	X
Cistus Hybridus (White Rockrose)	-	-	X	-	-	X	X
Cistus Purpureus (Purple Rockrose)	-	-	X	-	-	X	X
Mahonia Aquifolium "Compacta" (Oregon Grape)	X	X	X	X	X	X	X
Raphiolepis l. "Coates Crimson" (Indian Hawthorn)	-	-	X	X	X	X	X
Pinus Mugo Mughos (Dwarf Forms)	X	X	X	X	X	X	X

cited in Cal. Rest. Ass'n v. City of Berkeley  
 No. 21-16278am archived December 27, 2023

#### **Revision Notes**

Revision 04 has the following changes:

1. Revised Note 6 and Note 8 on Page 1.

Prepared by: MZGD

	<b>METHODS AND REQUIREMENTS FOR INSTALLING RESIDENTIAL UNDERGROUND ELECTRIC SERVICES 0 – 600 V TO CUSTOMER-OWNED FACILITIES</b>		<b>063927</b>
	<b>Asset Type:</b> Electric Distribution		<b>Function:</b> Design
<b>Issued by:</b> Lisseth Villareal (LDV2)		<b>Date:</b> 03-25-22	
<b>Rev. #24:</b> This document replaces PG&E Document 063927, Rev. #23. For a description of the changes, see Page 7.			

**This document is also included in the following manual:**

- [Electric and Gas Service Requirements \(Greenbook\)](#)
- [Electric Design Manual](#)

**Purpose and Scope**

This document shows the methods and requirements for installing PG&E-owned, underground service cables in customer-owned, residential, terminating facilities. See [Document 058817](#) for terminating underground services.

**General Information**

- Underground electric service laterals are normally installed in a PG&E service trench or in a joint trench with natural gas and communication service facilities.
- To determine the most satisfactory meter location, PG&E should be contacted for requirements while the building is in the planning stage.
- When it is necessary to install a service 75 feet or longer, the applicant must contact PG&E before ordering the service riser, conduit, or termination enclosure. The service riser and/or conduit specified in Table 3 on Page 5 of this document will not accept the cable required to meet flicker and/or voltage drop requirements, a larger conduit must be installed. This could require the installation of a larger termination enclosure.
- Install a splice box whenever cable pulling tensions may be exceeded or whenever there is a change in cable or conduit size.
- Ensure that any new installed secondary distribution cable is not smaller, either in size or in number of runs, than the largest new service that is on the load side of that new secondary system. For example, if the largest service required will be 1–350 Al, then the secondary must be a minimum of 1–350 Al. The existing secondary distribution system can remain as is if it can adequately supports any new services without causing loading, voltage drop, and voltage flicker issues.

**Residential Services Information**

- A “residential service” is a service supplying a single or multi-metered residential building. This document addresses services through 600 amp, single-phase for 120/240 V. For three-phase residential services or services larger than 600 amp, see [Document 063928](#). Single-phase main service switches must not exceed 225 amps for 120/208 V services.
  - Standard voltage for single metered residential building is 120/240 V.
  - All single-phase, 120/208 V services require full-sized neutral.
  - 800 amp single phase services are not allowed. 800 amp rated services and larger must be three-phase, and terminate in pad-mounted switchgear.
- Minimum service requirements.
  - Install the number and size of conduits as shown in Table 3 on Page 5, based on the main service panel rating. No more than seven service conduits, of any size, will be supplied from any one transformer.
  - Install the number and size of conductors, as shown in Table 3 on Page 5, to meet the individual initial demand load. Take load characteristics and growth into consideration.
  - It is permissible to install a smaller transformer and fewer conductors to serve a long term initial load with the intent of installing a larger transformer and additional conductors should future load increase occur.

## Methods and Requirements for Installing Residential Underground Electric Services 0 – 600 V to Customer-Owned Facilities

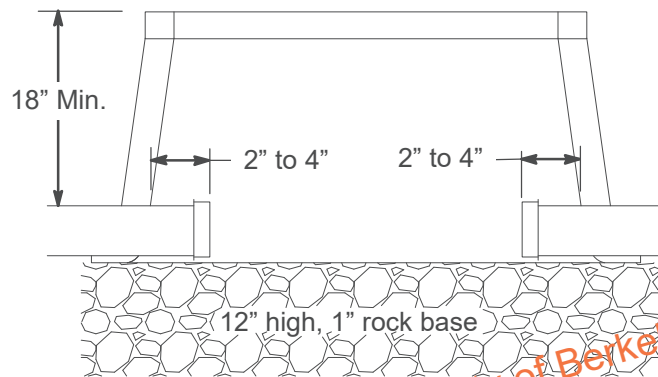
- D. Always size the transformer pad to accommodate the largest transformer size necessary to serve the combined ampacity of all services. Never exceed more than seven sets of conductors per transformer.
- E. Vacant ducts, if any, are to be used to serve future load increases.
8. Residential design includes mobile home and mobile home parks parks that are individually metered and not master-metered. For mobile home park design requirements see [Document 052521](#), “Electrical Service Requirements for Mobile Home Developments”.
9. Conduit is required for residential services, including multi-metered residential buildings.
10. The applicant must provide the trench, conduit, and backfill in accordance with [Electric Rule 16](#) and PG&E requirements. PG&E will furnish and install the service cables and make the connection at the point of service delivery in the applicant’s service termination enclosure.
- Qualification of material for use as backfill is the responsibility of the job foreman or, in the case of contract work, the inspector or their designer. A visual inspection of the material is sufficient for evaluation of the material. The source of the backfill, native or import, is immaterial to the suitability of the backfill for use in the trench. In new construction areas, the developer may be required to have a soils report available, which will assist in determining if import backfill is necessary.
11. Soil compaction must meet PG&E’s and any applicable federal, state, county, and local requirements. PG&E specific soil compaction requirements are as follows:
- A. Trenches that run across or along public roads and streets in the franchise areas must have soil compacted to a minimum of 95% density.
- B. Trenches that run across private properties and in all other areas must have soil compacted to a minimum of 90% density.
- C. A compaction test report may be required by PG&E. This report must include the testing company information: Name, Address, Contact information.
12. Service conduits installed through or under the applicant’s building foundation/slab must not exceed 20’ past the outside wall of the building and must terminate into the electrical room. See Figure 4 in Page 6. The installation requirements and conduit types for PG&E’s service conductors used in this application must be as indicated below;
- A. Conduits must not pass under or through one building to supply adjacent buildings.
- B. UL651 approved PVC Schedule 40 or 80.
- C. Galvanized Rigid Steel (GRS). GRS conduit is required when the conduit will be exposed, installed along walls and low clearance ceilings, and may be subject to damage from vehicles, machinery, or tools.
13. To avoid cable insulation damage, the ends of conduits must be provided with a suitable fitting, such as a bushing, hub, or end bell.
14. When an applicant’s main service panel is installed in an electric meter and service termination room, the room must be built with one wall and a door that leads to the outside of the applicant’s building. See [Greenbook Section 5.3.4](#), Electric Meter Rooms.
15. When service terminations/connections are made at the customer termination can or pull section, whether the service is left energized or de-energized,
- A. Cover and seal all meter sockets with an approved blank-off cover (Pie Plate) or set the electric meter(s). Material codes for electric meter socket covers are **M249424** and **M249559**.
- B. Seal all seal-able covers on the customer owned panel using PG&E approved seals.
16. Potential water intrusion into service conduits and meter termination facilities.
- A. Water intrusion into service conduits and meter termination facilities may occur if the source side of the service facilities (e.g., secondary splice box) is at an elevation greater than the meter termination facilities.
- B. [CPUC General Order 128, Rule 31.6](#) requires “Lateral ducts for services to buildings, through which water may enter buildings, must be plugged or sealed at the customer meter panel and at the source end of the service conduit.”
- C. When the intrusion of water into the service and metering equipment can be reasonably expected through lateral ducts, the conduits must be sealed at both ends using one of the PG&E approved sealing method shown in [Document 062288](#).

cited in Cal. Res. Ass'n v. City of Berkeley  
 No. 21-1627800 archived December 27, 2023

**Methods and Requirements for Installing Residential  
Underground Electric Services 0 – 600 V  
to Customer-Owned Facilities**

**UG-1: Services  
Greenbook  
EDM**

- D. If the meter termination facilities are significantly lower than the source side facilities, use the Rayflate Duct Sealing System (RDSS) conduit sealing system listed in [Document 062288](#).
- E. The applicant is responsible for providing a means to prevent the accumulation of excess water pressure in the service conduit system. This is accomplished by the following methods:
- (1) For wall-mounted service and metering equipment install an enclosure, outside, at the base of the riser to the meter panel, or at a maximum of 6 feet away from the meter panel along the service run.
    - (a) Install a 26" deep #2 enclosure, and enter through the short walls making sure to maintain the 18" minimum depth from finish grade to the top of the conduit. See Figure 1 on Page 3.
    - (b) Install the enclosure on a twelve-inch base of one-inch rock to aid in the drainage of the unwanted water, align the conduits at either end to achieve a nearly straight through pull and install end bell fittings on all conduits.
    - (c) Seal both ends of the service conduit from the drain enclosure to the customer meter panel.



**Figure 1  
Conduit Installation in a Drain Box**

- (2) For indoor electric meter rooms below grade level, a reliable method of water mitigation and drainage must be incorporated into the design of the meter room(s) to prevent the accumulation of water.
17. Prior to cable installation, all conduits must be proven free and clear by means of a mandrel or other methods acceptable to PG&E. A polyester flat pulling tape, white with sequential footage markings every foot, 2,500 minimum tensile strength, and approved by PG&E (**Code M560154**), must be installed in all conduits and attached to an end cap (see [Document 063928](#)).

#### Upgraded Panel

18. For upgraded panels where the new specified size of service conductor will fit in the existing conduit, it is not necessary to upgrade the conduit to the currently specified size and number for the new panel if all of the following are met:
- A. The maximum conduit fill ratio is not exceeded.
  - B. The calculated cable pulling tensions along the conduit route is within limits of the new cable.
  - C. Copper or larger size of Aluminum cable is able to handle full load in existing number of conduits. See Table 1 below.

**Table 1 Service Cable Size Allowed in Existing Conduit When Upgrading Panels**

Existing Service Equipment Rating (amps)	New Upgrade Service Equipment Rating (amps)	Minimum Allowed Existing Conduit Size and Number	Aluminum or Copper Cable Required to Serve Maximum Load AWG or kcmil <sup>1</sup>	
			(Per Phase)	Neutral
100–125	200–225	1–2"	1–4/0 Al	1–1/0 Al
200–225	320	1–3"	1–350 Al	1–4/0 Al
320	400	1–3"	1–750 Al	1–4/0 Al
400	600	1–4"	1–1000 Al <sup>2</sup>	1–350 Al

<sup>1</sup> Mixing Aluminum and Copper cable runs for the same service is not allowed.

<sup>2</sup> Center conduit underneath middle hot leg to allow flexibility to terminate the conductor.

**Methods and Requirements for Installing Residential  
Underground Electric Services 0 – 600 V  
to Customer-Owned Facilities**

- 19. If the new panel is able to accommodate it, the existing service conductor may be reused provided it meets the load, voltage drop, and flicker requirements of the new load. If the service conductor size must be upgraded, the existing conduit must be proofed with a mandrel.
- 20. For existing panels that are less than 36” horizontally away from the gas service riser, it is allowed to use the existing service conduit and extend new conduit of the same size and material to a new panel location that is 36” or more away from the gas riser as long as all the parameters listed in Notes 18, 19, 20, and 21 are met.
  - A. For service runs that approach the front of the existing panel, directly or at an angle, the new conduit will need to start back along the existing conduit and far enough away from the new panel location to minimize additional bends in the conduit system.
  - B. The new total number of bends must be within the maximum 315° allowed for service conduit run. For further information refer to [Document 038193](#).
  - C. The new panel must be relocated no more than 20’ away from the existing panel.
- 21. For upgraded panels, splice boxes are not allowed on private property to accommodate customers’ existing services. Service cable needs to be brought up to our current standard conduit service system from the customer meter to PG&E point of secondary distribution.
- 22. Notes 18, 19, 20, and 21 do not apply to the following conditions:
  - A. Direct buried or Cable-In-Conduit (CIC) service cables. Direct buried and CIC service cables must be replaced with approved service cable and installed in approved service conduit.
    - (1) Splice boxes between the customer panel, with existing DB or CIC cable, and PG&E secondary distribution system are not allowed. See Note 22 above.
  - B. Upgraded electric meter panels that are within 36 inches of the gas service riser. The clearance requirements in [Greenbook Section 5.4.3](#), “Meter Set Clearance Requirements” must be met for upgraded and relocated meter panels.
  - C. New upgraded panels with a Service Equipment Rating (amps) that is more than one upgraded size than the existing panel, as specified in Table 3 on Page 5. For example, if an existing panel less than or equal to 100 amps is upgraded to a 400 amp panel instead of a 200 amp panel.
  - D. If the existing cable size is more than one size smaller than the cable required to serve maximum load for the new panel, as specified in Table 3 on Page 5. For example, if the existing cable is #2 AWG aluminum and new upgraded panel requires 4/0 aluminum.

**Cover**

- 23. A minimum of 24 inches of cover for secondary (0 - 750 V) electric service, or 36 inches minimum cover for primary (over 750 V) is required. Cover is the distance from the outer surface of an underground facility to the top of the final grade. The actual trench depth will be greater (approximately 30 inches or 42 inches minimum respectively) to accommodate the underground facility, bedding, enclosures, riser sweeps, and joint trench installations with other utilities.

**Temporary Service**

- 24. The policy of using permanent service panels to supply temporary power is expanding. Schedule 40 or 80 PVC riser conduit may be damaged by staples and nails, and this has resulted in damage to service cables. Therefore, for those locations where cable will be installed or that will be energized prior to completion of the wall, the conduit must be Schedule 40, rigid steel conduit, to protect the service cables from damage caused by siding nails, etc. Refer to [Greenbook Section 5.9.1](#), “Temporary Service Using Permanent Service Panels”.

**Table 2 Service Conduit Types Approved for Underground Application**

Type	Specification <sup>3</sup> (must be marked on conduit)
Hot-Dip, Galvanized, Rigid Steel	ANSI Spec. C80.1
PVC, Co-extruded Cellular Core PVC, Schedule 40 or 80	UL 651, or ETL conforms to UL 651

<sup>3</sup> The entire “conduit system” must meet the specifications listed above. The conduit system includes conduits, conduit bends, conduit fittings or couplings and all related components (e.g., end bells and cable protectors) that are needed to install PG&E cables and conductors.

**Methods and Requirements for Installing Residential  
Underground Electric Services 0 – 600 V  
to Customer-Owned Facilities**

**UG-1: Services  
Greenbook  
EDM**

**Table 3 Service Conduit Types Approved for Underground Application Cable and Conduit Requirements for Residential Services**

Service Equipment Rating (amps) <sup>1</sup>	Conduit Size and Number <sup>2</sup>	Minimum Vertical Radius	Minimum Horizontal Radius	Aluminum Cable Required to Serve Maximum Load AWG or kcmil <sup>6</sup>	
				(Per Phase)	Neutral
100–125	1–2"	24"	36"	1–1/0	1–#2
200–225	1–3"	24"	36" <sup>7</sup>	1–4/0	1–1/0
320 <sup>3</sup>	1–3"	24"	36" <sup>7</sup>	1–350	1–4/0
400 <sup>4, 5</sup>	1–4"	36"	36"	1–750	1–4/0
600 <sup>4, 5</sup>	2–3"	24"	36" <sup>7</sup>	2–350	2–4/0

<sup>1</sup> Service rating must be the termination section, pullcan, service section, or main service switch continuous current rating, whichever is greater.

<sup>2</sup> See Note 3 on Page 1 for size and distance limitations, Note 12 on Page 2 for conduit type allowed on or within buildings, and Table 2 above for conduit type allowed underground.

<sup>3</sup> Require manual bypass facilities.

<sup>4</sup> Require transformer rated meter.

<sup>5</sup> Requires two bolt terminations and cable to spade connectors. Lay-in lugs are not allowed.

<sup>6</sup> Cable size shown in Table 3 is the minimum size cable that must be used.

<sup>7</sup> Available only on 90 degree bends.

## Service Installation

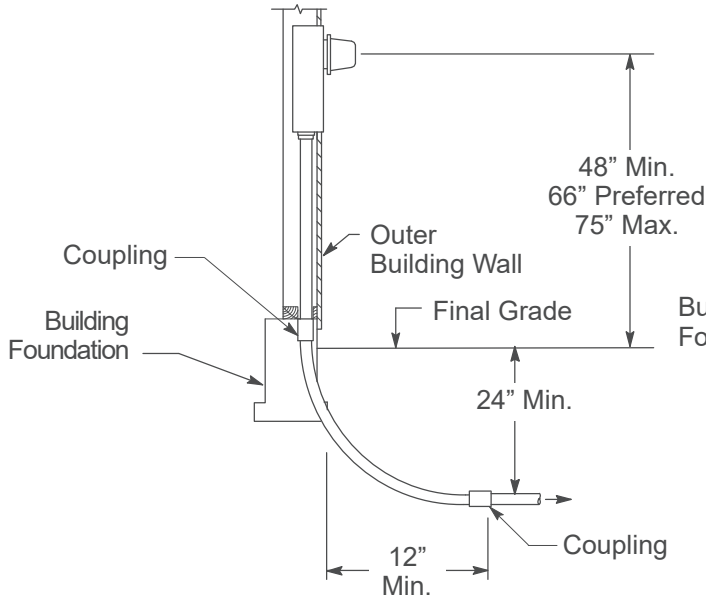
### Notes

1. A Vertical 90° manufactured sweep is required to be installed to meet trench grade. The riser conduit must not protrude away from the wall or mounted panel.
  - A. Couplings on the riser conduit installed inside the building foundation must be no higher than flush with the top of the concrete. Couplings installed outside building foundation must be installed a minimum of 6" below final grade.
2. The conduit end must extend at least 12 inches away from the foundation. Install the sweep in the direction of the service trench. If a deeper trench is required, the sweep must extend to the same depth as the conduit in the trench.
3. A minimum of 24 inches of cover must be maintained from the top of conduit to final grade.
4. See [Greenbook Section 5.4.3](#) for electric service and metering room requirements.
5. See [Greenbook Section 3.2.2](#) for establishing PG&E and applicants underground electric service responsibilities.

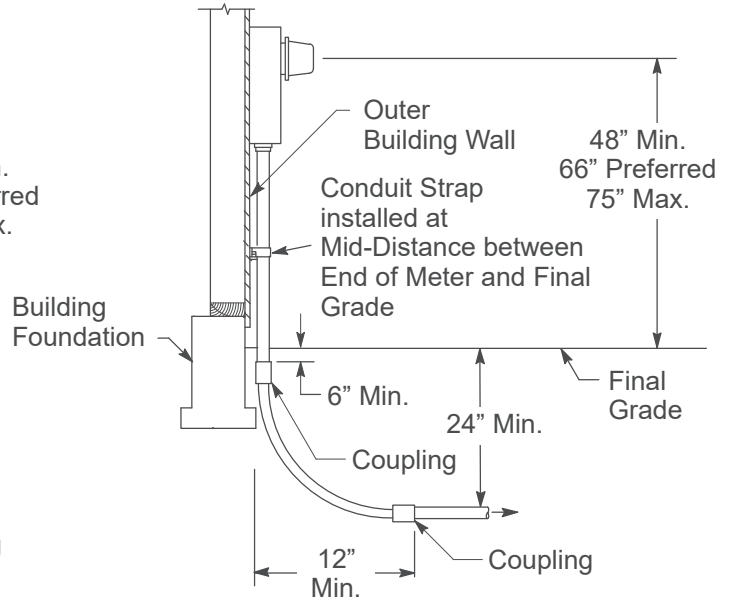


**Methods and Requirements for Installing Residential  
Underground Electric Services 0 – 600 V  
to Customer-Owned Facilities**

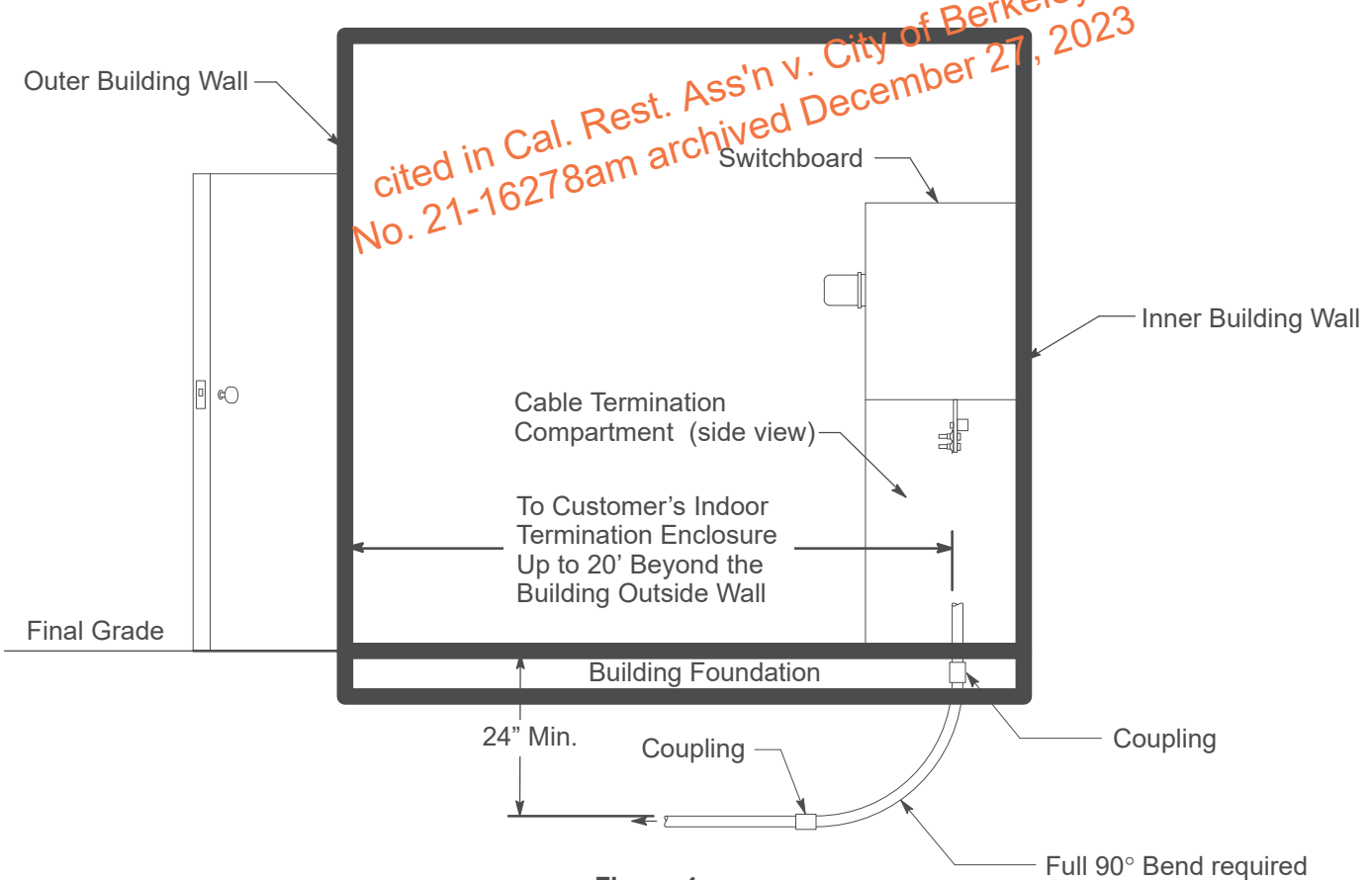
**Service Installation (Continued)**



**Figure 2**  
**Recessed-Mounted Service Termination Enclosure**



**Figure 3**  
**Surface-Mounted Service Termination**



**Figure 4**  
**Indoor Service Termination and  
Metering Enclosure in Electric Room**

**Methods and Requirements for Installing Residential  
Underground Electric Services 0 – 600 V  
to Customer-Owned Facilities**

**UG-1: Services  
Greenbook  
EDM**

<b>References</b>	<b>Location</b>	<b>Document</b>
<a href="#">Secondary Electric Underground Enclosures</a> .....	<a href="#">UG-1: Enclosures/Greenbook</a> .....	<a href="#">028028</a>
<a href="#">Minimum Requirements for the Design and Installation of Electric Conduit, Insulated Cable, and Facilities</a> .....	<a href="#">UG-1: General/Greenbook</a> .....	<a href="#">038193</a>
<a href="#">Electrical Service Requirements for Mobile Home Developments</a> .....	<a href="#">Greenbook/EMWP</a> .....	<a href="#">052521</a>
<a href="#">Terminating Underground Electric Services 0–600 Volts in Customer-Owned Facilities</a> .....	<a href="#">UG-1: Services/Greenbook</a> .....	<a href="#">058817</a>
<a href="#">Underground Conduits</a> .....	<a href="#">UG-1: Conduits/Greenbook</a> .....	<a href="#">062288</a>
<a href="#">Methods and Requirements for Installing Non-Residential Underground Electric Services 0–600 Volts to Customer-Owned Facilities</a> .....	<a href="#">UG-1: Services/Greenbook</a> .....	<a href="#">063928</a>

### Revision Notes



Revision 24 has the following changes:

1. Updated Note 5 on Page 1.
2. Revised Note 6 on Page 1 to add limit to single-phase service for 120/200V.
3. Modified Note 7A on Page 1.
4. Added compaction requirements to Note 10 on Page 2.
5. Modified Note 11 on Page 2.
6. Moved section of what used to be part of Note 12 to new Note 13 on Page 2.
7. Added new Note 15 on Page 2.
8. Re-structured Note 16 on Page 2.
9. Added Note 18C on Page 3.
10. Added new Figure 1 on Page 3.
11. Added new Table 1 on Page 3.
12. Added new Notes 20 and 21 on Page 4.
13. Added Note 22A1 on Page 4.
14. Added Note 1A under Service Installation on Page 5.
15. Modified Figures 2, 3, and added Figure 4 on Page 6.
16. Moved Reference sections to the end of the document before Revision notes on Page 7.
17. Added document 038193 to Reference Section on Page 7.

cited in Cal. Rest. Ass'n v. City of Berkeley  
No. 21-16278am archived December 27, 2023

cited in Cal. Rest. Ass'n v. City of Berkeley  
No. 21-16278am archived December 27, 2023

Prepared by: MZGD

	<b>METHODS AND REQUIREMENTS FOR INSTALLING NON-RESIDENTIAL UNDERGROUND ELECTRIC SERVICES</b>		<b>063928</b>
	<b>0 – 600 VOLTS TO CUSTOMER-OWNED FACILITIES</b>		
<b>Asset Type:</b>	Electric Distribution	<b>Function:</b>	Design and Construction
<b>Issued by:</b>	Lisseth Villareal (LDV2) 	<b>Date:</b>	03-25-22
<b>Rev. #26:</b> This document replaces PG&E Document 063928, Rev. #25. For a description of the changes, see Page 9.			

**This document is also included in the following manuals:**

- [Electric and Gas Service Requirements \(Greenbook\)](#)
- [Electric Design Manual](#)

**Purpose and Scope**

This document shows the methods and requirements for installing PG&E-owned underground service conductors in commercial buildings and three-phase multi-residential buildings. For agricultural underground service refer to [Document 054619](#)

**General Information**

1. See [Document 058817](#) for terminating underground electric service 0–600 V in customer owned facilities.
2. Single-phase main service switches must not exceed 200 amps for 120/208 V services or 600 amps for 120/240 V services. All single-phase, 120/208 V services require full sized neutrals.
3. Ensure that any new installed secondary distribution cable is not smaller, either in size or in number of runs, than the largest new service that is on the load side of that new secondary system. For example, if the largest service required will be 1-350 Al, then the secondary must be a minimum of 1-350 Al. The existing secondary distribution system can remain as is if it can adequately support any new services without causing loading, voltage drop, and voltage flicker issues.

**Customer Requirements**

4. The applicant must provide trench and backfill in accordance with Electric Rule 16 and PG&E requirements. PG&E will furnish and install the service cables and make the connection at the point of service delivery in the applicant's service termination enclosure. Qualification of material for use as backfill is the responsibility of the job foreman or, in the case of contract work, the inspector or their designer. A visual inspection of the material is sufficient for evaluation of the material. The source of the backfill, native or import, is immaterial to the suitability of the backfill for the use in the trench. In new construction areas, the developer may be required to have a soil report available, which will assist in determining if import backfill is necessary. Soil compaction must meet PG&E's and any applicable federal, state, county, and local requirements. PG&E specific soil compaction requirements are as follows:
  - A. Trenches that run across or along public roads and streets in the franchise areas must have soil compacted to a minimum of 95% density.
  - B. Trenches that run across private properties and in all other areas must have soil compacted to a minimum of 90% density.
  - C. A compaction test report may be required by PG&E. This report must include the testing company information: Name, Address, Contact Information.

## Methods and Requirements for Installing Non-Residential Underground Electric Services 0 – 600 Volts to Customer-Owned Facilities

5. Service conduits installed through or under the applicant's building foundation/slab must not exceed 20' past the outside wall of the building and must terminate into the electrical room. See Figure 4 on Page 8. The installation requirements and conduit types for PG&E service conductors used in this application must be as indicated below;
  - A. Conduits must not pass under or through one building to supply adjacent buildings.
  - B. UL651 approved PVC Schedule 40 or 80.
  - C. Galvanized rigid steel (GRS). GRS conduit is required when the conduit will be exposed, installed along walls and low clearance ceilings, and may be subject to damage from vehicles, machinery or tools.
6. To avoid cable insulation damage, the end of the conduit must be provided with a suitable termination fitting such as a bushing, hub, or end bell.
7. When an applicant's main service panel is installed in an electric meter and service termination room, the room must be built with one wall and a door that leads to the outside of the applicant's building. See Figure 4 on Page 8. See [Electric and Gas Service Requirements \(Greenbook\) Section 5.3.4](#) "Electric Meter Rooms".
8. State or local building codes require special conduit seals in certain locations, such as gasoline and hydrogen filling stations. If the underground service conduit runs within a 20' horizontal radius of a gas pump (from any edge of the dispenser enclosure), or within a 10' horizontal radius of an underground gas tank. Similarly, if the underground service conduit runs within a 5' horizontal radius of a hydrogen cooling block, dispenser, or storage, or within 15' horizontal radius of a hydrogen compressor, services should maintain the required clearances listed in this note all the way to the customer meter panel so the electric conduit and cable are designed per PG&E current requirements. Otherwise, the applicant is be responsible for meeting PG&E, the National Electric Code (NEC), Canadian Electric Code (CEC) or Local Authority Having Jurisdiction (AHJ) requirements listed in A–C below:
  - A. The type of conduit required from the meter termination point to the connection point with PG&E.
    - (1) Install PG&E approved secondary number 5 concrete box. See [Document 036628](#) for ordering information.
    - (2) Use approved secondary multi-ways tap slices for PG&E to join PG&E's secondary cable to customer owned cable. See [Document 036640](#) for ordering information.
  - B. The installation and maintenance of special fittings (explosion-proof) and sealing compounds at both ends.
  - C. The type of cable required from the meter termination point to the connection point with PG&E. This section of cable is customer owned, installed and maintained.
9. Prior to cable installation, prove all conduits free and clear by means of a mandrel PG&E approved. A PG&E-approved polyester, flat pulling tape, white with sequential footage markings every foot, and 2,500-pound minimum tensile strength (**Code M560154**), must be installed in all conduits and attached to an end cap.
10. Install a splice box whenever cable pulling tensions are exceeded, or a change in cable or conduit size is required. The applicant must contact the local PG&E office to determine these requirements.
11. Test bypass facilities are required for both single phase and three phase non-residential installations regardless of the panel ampacity.

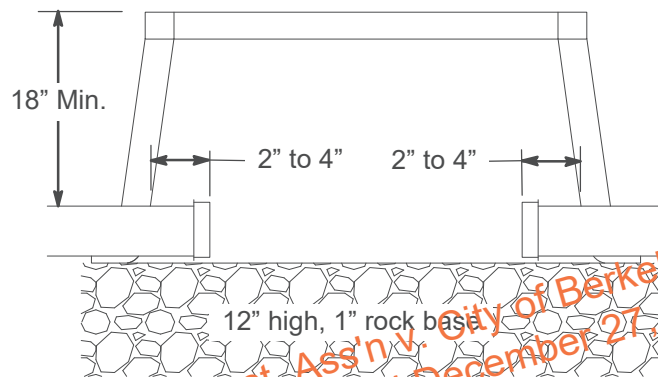
### PG&E Requirements

12. If PG&E service conductors are to be run in a multiple conduit system, all phases and the neutral must be installed in each conduit that is used.
13. PG&E will furnish and install the underground service conductors and make connections in the applicant's service termination enclosure.
14. Potential water intrusion into service conduits and meter termination facilities
  - A. Water intrusion into service conduits and meter termination facilities may occur if the source side of the service facilities (e.g., secondary splice box) is at an elevation greater than the meter termination facilities.
  - B. [CPUC General Order 128, Rule 31.6](#) requires "Lateral ducts for services to buildings, through which water may enter buildings, must be plugged or sealed."
  - C. When the intrusion of water into the service and metering equipment can be reasonably expected through lateral ducts, the conduits must be sealed at both ends using one of the PG&E approved sealing method shown in [Document 062288](#).
  - D. If the meter termination facilities are significantly lower than the source side facilities, use the Rayflute Duct Sealing System (RDSS) conduit sealing system listed in [Document 062288](#).

**Methods and Requirements for Installing Non-Residential  
Underground Electric Services  
0 – 600 Volts to Customer-Owned Facilities**

**UG-1: Services  
Greenbook  
EDM**

- E. The applicant is responsible for providing a means to prevent the accumulation of excess water pressure in the service conduit system. This is accomplished by the following methods:
- (1) For wall-mounted service and metering equipment install an enclosure, outside, at the base of the riser to the meter panel, or at a maximum of 6 feet away from the meter panel along the service run.
    - (a) For 4" service conduit or smaller, install a 26" deep #2 enclosure, and enter through the short walls, making sure to maintain the 18" minimum depth from finish grade to top of the conduit. See Figure 1 on Page 3.
    - (b) For 5" service conduit (up to 3 conduits), install a 26" deep #3 enclosure, and enter through the short walls, making sure to maintain the 18" minimum depth from finish grade to the top of the conduit. See Figure 1 below.
    - (c) For either 14E(1)(a) or 14E(1)(b) box installation, install the enclosure on a twelve-inch base of, one-inch rock to aid in the drainage of the unwanted water, align the conduits at either end to achieve a nearly straight pull and install end bell fittings on all conduits.
    - (d) Seal both ends of the service conduit from the drain enclosure to the customer meter panel.



**Figure 1  
Conduit Installation in a Drain Box**

- (2) For indoor electric meter rooms below grade level, a reliable method of water mitigation and drainage must be incorporated into the design of the meter room(s) to prevent the accumulation of water.
15. When service termination/connections are made at the customer termination can or pull section, whether the serviced is left energized or de-energized,
    - A. Cover and seal all meter sockets with an approved blank-off cover (Pie Plate) or set the electric meter(s). Material codes for electric meter socket covers are **M249424** and **M249559**.
    - B. Seal all seal-able covers on the customer owned panel using PG&E approved seals.
  16. Minimum service requirements
    - A. Install the number and size of conduits as shown in Table 4 on Page 6 and Table 5 on Page 7, based on the main service panel rating. No more than seven service conduits, of any size, will be supplied from any one transformer.
    - B. Install the number and size of conductors, as shown in Table 4 on Page 6, to meet the individual initial demand load. Take load characteristics and growth into consideration.
    - C. It is permissible to install a smaller transformer and fewer conductors to serve a long term initial load with the intent of installing a larger transformer and additional conductors should future load increase occur.
    - D. Always size the transformer pad to accommodate the largest transformer size necessary to serve the combined ampacity of all services. Never exceed more than seven sets of conductors per transformer.
    - E. Vacant ducts, if any, are to be used to serve future load increases.
  17. Single main service panels fed by single transformer
 

Example 1

480 V, 4-wire, 1,600-amp rated main switch, initial demand load is 300 kVA. Install five 5-inch ducts, service size is 1,000 kcmil for phase and 350 kcmil for neutral. Only two sets of service conductors are required to meet initial loading. The remaining three ducts should be capped for future use.

**Methods and Requirements for Installing Non-Residential  
Underground Electric Services  
0 – 600 Volts to Customer-Owned Facilities**

18. Multiple main service panels fed by single transformer

Example 2

1,000-amp, 600-amp, and 400-amp mains to be served. The number of sets of conduits required are three, two, and one, respectively. A total of six conduits are needed to serve the three main switches. The three services can be served from one transformer.

19. Multiple main service panels fed by multiple transformers

Example 3

2,000-amp and 1,000-amp mains to be served. The number of sets of conduits required are seven and three respectively. A total of ten conduits are needed to serve the two main switches. The two services cannot be served from one transformer; they must be served from individual transformers.

**Cover**

20. A minimum of 24 inches of cover for secondary (0 – 750 V) electric service, or 36 inches minimum cover for primary (over 750 V) is required. Cover is the distance from the outer surface of an underground facility to the top of the final grade. The actual trench depth will be greater (approximately 30 inches or 42 inches minimum respectively) to accommodate the underground facility, bedding, enclosures, riser sweeps, and joint trench installations with other utilities.

**Upgraded Panel**

- 21. For upgraded panels where the new specified size of service conductor will fit in the existing conduit, it is not necessary to upgrade the conduit to the currently specified size and number for the new panel if all of the following are met:
  - A. The maximum conduit fill ratio is not exceeded.
  - B. The calculated cable pulling tensions along the conduit route is within limits of the new cable.
  - C. Copper or larger size Aluminum cable can handle full load in existing number of conduits. See Table 1 and Table 2 below.

**Table 1 Service Cabled Size Allowed in Existing Conduit When Upgrading Single Phase Panels**

Existing Service Equipment Rating (amps)	New Upgrade Service Equipment Rating (amps)	Minimum Allowed Existing Conduit Size and Number	Aluminum or Copper Cable Required to Serve Maximum Load AWG or kcmil <sup>1</sup>	
			(Per Phase)	Neutral
100	200	1-3"	1-4/0 Al	1-1/0 Al
200	400	1-3"	1-750 Al	1-4/0 Al
400	600	1-4"	1-1000 Cu <sup>2,3</sup>	1-250 Cu

<sup>1</sup> Mixing Aluminum and Copper cable runs for the same service is not allowed.

<sup>2</sup> Limited to 50 feet of cable between the transformer secondary spades and the customer's gear connection point. For greater distances, an appropriately rated PG&E approved pad-mounted termination enclosure is allowed if installed per the requirements listed in the Greenbook. For either type of installation, the PG&E installed cable length must not exceed 50 feet.

<sup>3</sup> Center conduit underneath middle hot leg to allow flexibility to terminate the conductor.

**Methods and Requirements for Installing Non-Residential  
Underground Electric Services  
0 – 600 Volts to Customer-Owned Facilities**

**UG-1: Services  
Greenbook  
EDM**

**Table 2 Service Cable Size Allowed in Existing Conduit When Upgrading Three Phase Panels**

Existing Service Equipment Rating (amps)	New Upgrade Service Equipment Rating (amps)	Minimum Allowed Existing Conduit Size and Number	Aluminum or Copper Cable Required to Serve Maximum Load AWG or kcmil	
			(Per Phase)	Neutral
100	200	1–3"	1–4/0 Al	1–1/0 Al
200	400	1–3"	1–750 Al	1–4/0 Al
400	600	1–5"	1–1000 Cu <sup>2,3</sup>	1–250 Cu
600	800	2–5"	2–750 Al	2–4/0 Al
800	1000	2–5"	2–1000 Cu <sup>2</sup>	2–250 Cu
1000	1200	3–5"	3–750 Cu	3–250 Cu
1200	1600	4–5"	4–750 Cu	4–250 Cu
1600	2000	5–5"	5–1000 Cu <sup>2</sup>	5–250 Cu
2000	2500	7–5"	7–1000 Cu <sup>2</sup>	7–250 Cu

<sup>1</sup> Mixing Aluminum and Copper cable runs for the same service is not allowed.

<sup>2</sup> Limited to 50 feet of cable between the transformer secondary spades and the customer's gear connection point. For greater distances, an appropriately rated PG&E approved pad-mounted termination enclosure is allowed if installed per the requirements listed in the Greenbook. For either type of installation, the PG&E installed cable length must not exceed 50 feet.

<sup>3</sup> Center conduit underneath middle hot leg to allow flexibility to terminate the conductor.

22. If the new panel is able to accommodate it, the existing service conductor may be reused provided it meets the load, voltage drop, and flicker requirements of the new load. If the service conductor size must be upgraded, the existing conduit must be proofed with a mandrel.

23. For existing panels that are less than 36" horizontally away from the gas service riser; it is allowed to use the existing service conduit and extend new conduit of the same size and material to a new panel location that is 36" or more away from the gas riser as long as all the parameters listed in Notes 21, 22 and 23 are met. This note only applies to panels that requires a total number of two service conduits.

A. For service runs that approach the front of the existing panel, directly or at an angle, the new conduit will need to start back along the existing conduit and far enough away from the new panel location to minimize additional bends in the conduit system.

B. The new total number of bends must be within the maximum 315° allowed for service conduit run. For further information, refer to [Document 038193](#).

C. The new panel must be relocated no more than 20' away from the existing panel.

24. Notes 21, 22 and 23 above do not apply to the following conditions.

A. Direct buried or Cable-In-Conduit (CIC) service cables. Direct buried and CIC service cables must be replaced with approved service cable and installed in approved service conduit.

(1) Splice boxes between the customer panel, with existing DB or CIC cable, and PG&E secondary distribution system are not allowed. Service cable needs to be brought up to our current standard conduit service system from the customer meter to PG&E point of secondary distribution.

B. Upgraded electric meter panels that are within 36 inches of the gas service riser. The clearance requirements in [Electric and Gas Service Requirements \(Greenbook\) Section 5.4.3](#), "Meter Set Clearance Requirements," must be met for upgraded and relocated meter panels.

C. New upgraded panels with a Service Equipment Rating (amps) that is more than one upgraded size than the existing panel, as specified in Table 4 on Page 6 and Table 5 on Page 7. For example, if an existing panel less than or equal to 100 amps is upgraded to a 400 amp panel instead of a 200 amp panel.

D. If the existing cable size is more than one size smaller than the cable required to serve maximum load for the new panel, as specified in Table 4 on Page 6 and Table 5 on Page 7. For example, if the existing cable is #2 AWG aluminum and new upgraded panel requires 4/0 aluminum.



**Methods and Requirements for Installing Non-Residential  
Underground Electric Services  
0 – 600 Volts to Customer-Owned Facilities**

**Temporary Service**

25. The policy of using permanent service panels to supply temporary power is expanding. Schedule 40 or 80 PVC riser conduit may be damaged by staples and nails, and this has resulted in damage to service cables. Therefore, for those locations where cable will be installed or that will be energized prior to completion of the wall, the conduit must be Schedule 40, rigid steel conduit, to protect the service cables from damage caused by siding nails, etc. Refer to [Electric and Gas Service Requirements \(Greenbook\) Section 5.9.1.](#), "Temporary Service Using Permanent Service Panels".

**Table 3 Service Conduit Types Approved for Underground Applications With Prior PG&E Approval**

Type	Specification <sup>4</sup> (must be marked on conduit)
Hot-Dip, Galvanized, Rigid Steel	ANSI C80.1
PVC, Co-extruded Cellular Core PVC Schedule 40 or 80	UL 651, or ETL conforms to UL 651

- <sup>4</sup> The entire "conduit system" must meet the specifications listed above. The conduit system includes conduits, conduit bends, conduit fittings or couplings and all related components (e.g., end bells and cable protectors) that are needed to install PG&E cables and conductors.

**Table 4 Cable and Conduit Requirements for Single-Phase Commercial Services**

Main Service Panel Rating (amps) <sup>1</sup>	Conduit Size and Number	Cables Required to Serve Maximum Load <sup>3</sup>			
		Aluminum		Copper	
		Per Phase	Neutral	Per Phase	Neutral
100	1-3"	1-1/0	1-#2	NA	NA
200	1-3"	1-4/0	1-1/0	NA	NA
400 <sup>2</sup>	1-4"	1-750	1-4/0	NA	NA
600 <sup>2</sup>	2-4"	2-750	2-4/0	NA	NA

- <sup>1</sup> Service rating must be the termination section, pullcan, service section, or main service switch continuous current rating, whichever is greater. See Note 2 on Page 1 for 100-600 amp, 10 services.

- <sup>2</sup> Require transformer rated meter.

- <sup>3</sup> Cable size shown in Table 4 is the minimum size cable that must be used.

**Methods and Requirements for Installing Non-Residential  
Underground Electric Services  
0 – 600 Volts to Customer-Owned Facilities**

**UG-1: Services  
Greenbook  
EDM**

**Table 5 Cable and Conduit Requirements for Three-Phase Commercial Services <sup>1</sup>**

Main Service Panel Rating (amps) <sup>2</sup>	Conduit Size and Number	Cables Required to Serve Maximum Load <sup>6</sup>			
		Aluminum		Copper	
		Per Phase	Neutral	Per Phase	Neutral
100	1-3"	1-1/0	#2	NA	NA
200	1-3"	1-4/0	1-1/0	NA	NA
400	1-5"	1-750	1-4/0	NA	NA
600	2-5"	2-750	2-4/0	NA	NA
800	2-5"	2-750	2-4/0	NA	NA
1,000	3-5"	3-1,000	3-350	NA	NA
1,200 <sup>3</sup>	4-5"	4-1,000	4-350	NA	NA
1,600 <sup>3</sup>	5-5"	5-1,000	5-350	NA	NA
2,000 <sup>3</sup>	7-5"	7-1,000	7-350	NA	NA
2,500 <sup>3, 4</sup>	7-5"	NA	NA	7-1,000	7-250
3,000	Bus Duct	NA	NA	NA	NA
3,500 <sup>5</sup>	Bus Duct	NA	NA	NA	NA
4,000 <sup>5</sup>	Bus Duct	NA	NA	NA	NA

<sup>1</sup> 3,000-, 3,500-, and 4,000-amp service rated panels require using a bus duct.

<sup>2</sup> Service rating must be the termination section, pullcan, service section, or main service switch continuous current rating, whichever is greater.

<sup>3</sup> Requires termination provisions (i.e., longer bolts) that allow connectors to be stacked when needed.

<sup>4</sup> Limited to 50 feet of cable between the transformer secondary spades and the customer's gear connection point. For greater distances, a bus duct is preferred, but a PG&E approved pad-mounted termination enclosure 2,500-Amps rated is allowed if installed per the requirements listed in [Document 063929](#). For either type of installation, the PG&E installed cable length must not exceed 50 feet.

<sup>5</sup> Panels rated over 3000 amps cannot be served at 120/208 V.

<sup>6</sup> Cable size shown in Table 5 is the minimum size cable that must be used.

**Table 6 Minimum Bend Radius for New Construction**

Conduit Diameter	Vertical Radius	Horizontal Radius
2"	24"	36"
3"	24" <sup>1</sup>	36"
4"	36"	36"
5"	36"	60"

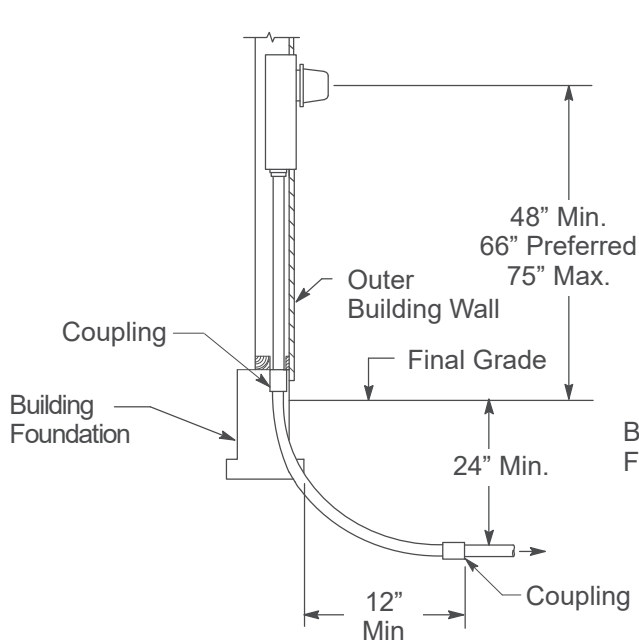
<sup>1</sup> Only available in 90° bends.

**Service Installation****Notes**

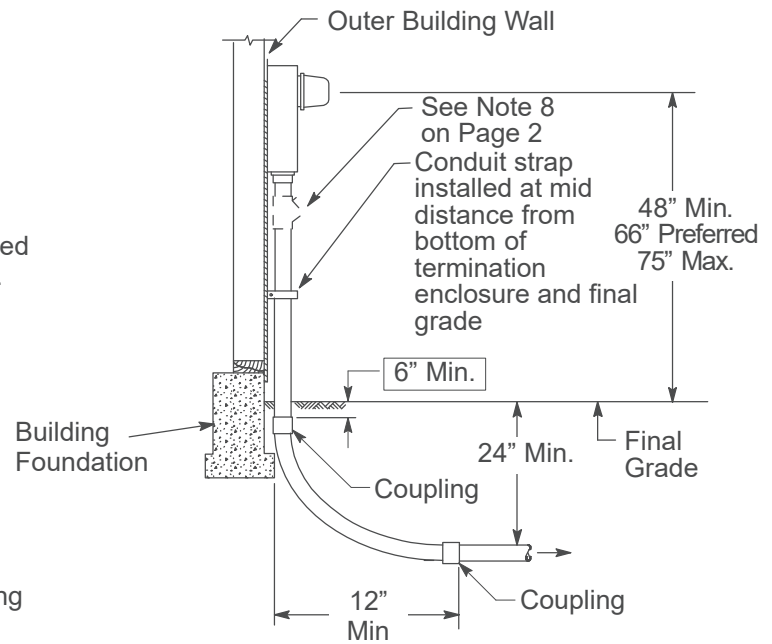
- A Vertical 90° manufactured sweep is required to be installed to meet trench grade. The riser conduit must not protrude away from the wall or mounted panel.
  - Couplings on the riser conduit installed inside the building foundation must be no higher than flush with the top of the concrete. Couplings installed outside building foundation must be installed a minimum of 6" below final grade.
- The conduit end must extend at least 12 inches away from the foundation. Install the sweep in the direction of the service trench. If a deeper trench is required, the sweep must extend to the same depth as the conduit in the trench.
- A minimum of 24 inches of cover must be maintained from the top of conduit to the final grade.
- See [Electric and Gas Service Requirements \(Greenbook\) Section 5.4.3](#) for electric and metering requirements.
- See [Electric and Gas Service Requirements \(Greenbook\) Section 3.2.2](#) for establishing PG&E and applicants underground electric service responsibilities.

**Methods and Requirements for Installing Non-Residential  
Underground Electric Services  
0 – 600 Volts to Customer-Owned Facilities**

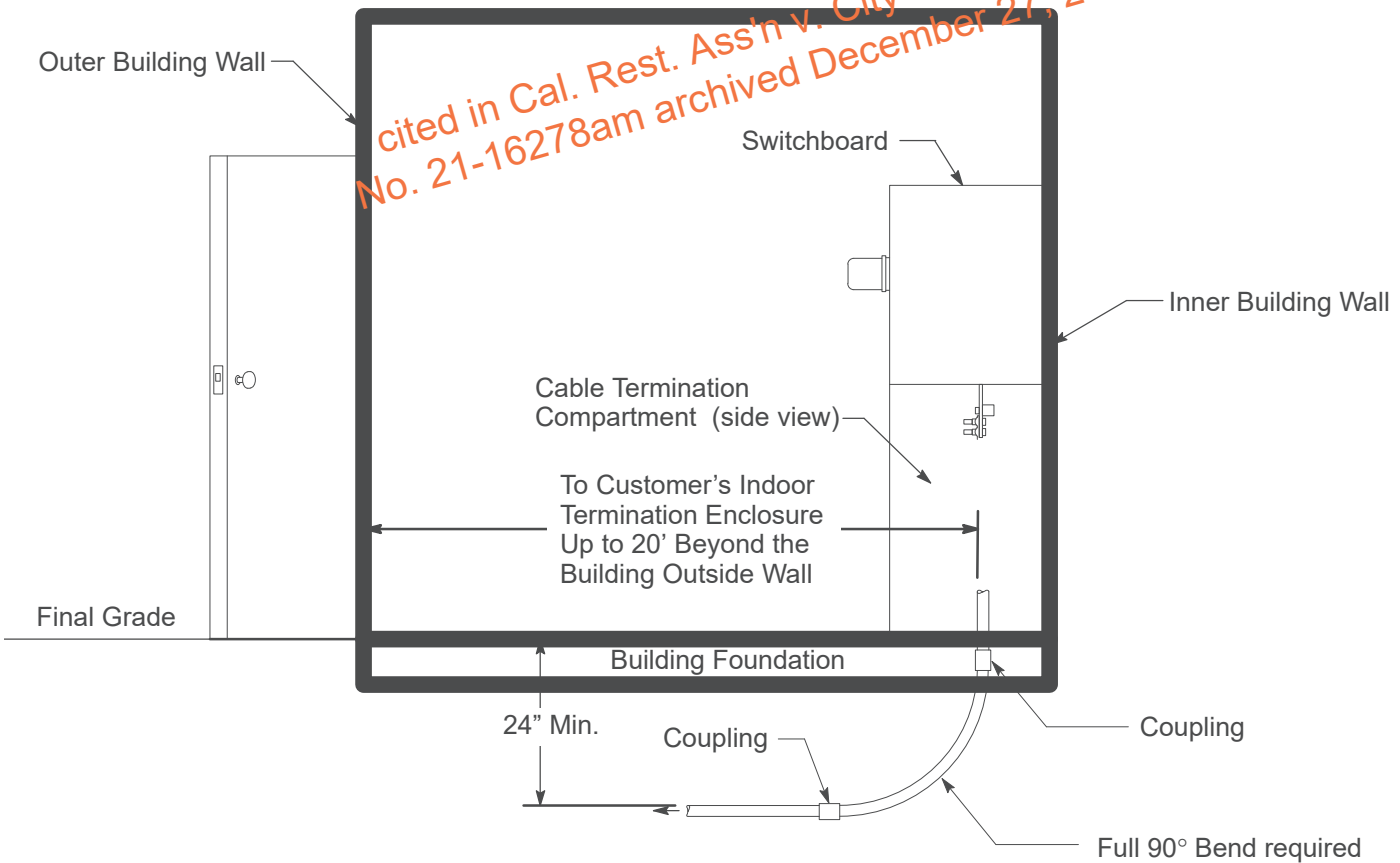
**Service Installation (Continued)**



**Figure 2**  
**Recessed-Mounted Service Termination Enclosure**



**Figure 3**  
**Surface-Mounted Combination Meter Socket Panel**



**Figure 4**  
**Indoor Service Termination and  
Metering Enclosure in Electric Room**

**Methods and Requirements for Installing Non-Residential  
Underground Electric Services  
0 – 600 Volts to Customer-Owned Facilities**

**UG-1: Services  
Greenbook  
EDM**

References	Location	Document
<a href="#">Methods and Requirements for Installing Commercial Underground Electric Services 0 – 600 Volts to Customer-Owned Facilities</a> .....	<a href="#">UG-1: Enclosures/Greenbook</a> .....	<a href="#">028028</a>
<a href="#">Multi-Tap Splice for 600-Volt Insulated Cables</a> .....	<a href="#">UG-1: Splices</a> .....	<a href="#">036640</a>
<a href="#">Minimum Requirements for the Design and Installation of Electric Conduit, Insulated Cable, and Facilities</a> ..	<a href="#">UG-1: General/Greenbook</a> .....	<a href="#">038193</a>
<a href="#">Agricultural Underground Service 500 HP or Less</a> .....	<a href="#">UG-1 Services/Greenbook/EMWP</a> .....	<a href="#">054619</a>
<a href="#">Terminating Underground Electric Services 0-600 Volts in Customer-Owned Facilities</a> .....	<a href="#">UG-1: Services/Greenbook</a> .....	<a href="#">058817</a>
<a href="#">Underground Conduits</a> .....	<a href="#">UG-1: Conduits/Greenbook</a> .....	<a href="#">062288</a>
<a href="#">Requirements for Bus Duct Entrance Termination Unit for Use with Pad-Mounted Transformers</a> .....	<a href="#">UG-1: Services/Greenbook</a> .....	<a href="#">063929</a>


### Revision Notes

Revision 26 has the following changes:

1. Revised Note 1 and Note 3 on Page 1.
2. Changed 225A to 200A in Note 2 on Page 1.
3. Revised Note 4 on Page 1.
4. Revised Note 5 on Page 1. Note 5C became new Note 6 on Page 2.
5. Revised Note 8 on Page 2.
6. Revised Note 14C on Page 2 and new Figure 1 on Page 3.
7. Added New Note 15 on Page 3.
8. Modified Note 16A on Page 4.
9. Added Note 21C on Page 4.
10. Added new Table 1 and Table 2 on Page 4.
11. Added new Note 23 on Page 5.
12. Modified footnote 5 for Table 5 on Page 7.
13. Added table footnote 1 to Table 6 on Page 7.
14. Added Note 1A under services Installation on Page 7.
15. Modified Figures 2, 3 and added Figure 4 on 8.
16. Move References to the end of Document before Revision Notes.

cited in Cal. Rest. Ass'n v. City of Berkeley  
 No. 21-16278 am archived December 27, 2023

cited in Cal. Rest. Ass'n v. City of Berkeley  
No. 21-16278am archived December 27, 2023

	<b>REQUIREMENTS FOR BUS DUCT ENTRANCE TERMINATION UNIT</b>		<b>063929</b>
	<b>FOR USE WITH PAD-MOUNTED TRANSFORMERS</b>		
<b>Asset Type:</b>	Electric Distribution	<b>Function:</b>	Design and Construction
<b>Issued By:</b>	Lisbeth Villareal (LDV2)	<b>Date:</b>	10-29-19
<b>Rev. #12:</b> This document replaces PG&E Document 063929, Rev. #11. For a description of the changes, see Page 10.			

**This document is also included in the following manual:**

- [Electric and Gas Service Requirements Manual](#) (Greenbook)

**Purpose and Scope**

This document provides the tools, ordering instructions, and the necessary manufacturing specifications and details for the fabrication and assembly of bus duct entrance terminations.

The function of the entrance box is to:

- Provide a means for connecting the customer's bus duct to a pad-mounted transformer.
- Permit a future, larger transformer to be installed without disturbing the existing bus duct installation.
- Reduce the shutdown time for transformer replacement. The entrance box is furnished with two removable sections to permit access to the bus duct extension connections. PG&E will supply and install the entrance box.

**General Information**

1. The "Bus Duct Entrance Termination Unit" is used to provide transition from a customer-provided service entrance bus duct to the low-voltage service compartment of a PG&E, pad-mounted transformer, for services of 3,000 to 4,000 amps.
2. Construction
  - A. The unit's construction design shown in this document must comply with the Western Underground Committee's Guide 2.13, latest revision, for tamper-resistant, pad-mounted, equipment enclosures.
  - B. Each top and side cover must latch and securely self-lock at a minimum of three points, when the unit is assembled. All sharp external corners, edges, and joints must be smoothed to prevent injury or damage to clothing.
  - C. The edges, seams, and joints must be made and formed to provide a close-fitting mating surface. Exposed welding on the outside surface of the unit(s) must be a continuous bead, machined and ground flush.
  - D. All metal work must be cleaned free of dirt, oils, and rust, and immediately painted, both inside and outside, with one coat of suitable, rust-inhibiting primer, approximately 1.5 mils thick when dry.
  - E. The interior and exterior of the housing must be finished with one or more coats of Green Munsel, No. 7gy, 3.29/1.5 paint. The total dry film thickness must not be less than 2 mils (the total paint thickness, including primer, not less than 3.5 mils when dry).
  - F. Approximately a half pint of "touch-up" paint (preferably in an aerosol spray can) must be included and shipped with each unit (attached inside the unit to the cable support block).
3. Methods of Serving Large Commercial Customers
  - A. Main Service Rating 201 Through 2,500 Amps: The approved method is by underground cable in customer-installed conduit for cable distance 50 feet or less (refer to [Document 063928](#) for details).
  - B. Main Service Rating 3,000 Through 4,000 Amps: The approved method is a PG&E-owned and installed bus duct entrance box attaching to customer-owned and installed bus duct that is a minimum of 36" long.
4. Note: Bus ducts must only be connected to pad-mounted transformers with a minimum 30-inch deep cabinet and a secondary terminal height of 46 inches from the bottom of the cabinet (Style IIE-LB and IIF, 300 kVA and larger).

### Requirements for Bus Duct Entrance Termination Unit for Use With Pad-Mounted Transformers

5. It is recommended to install pad-mounted transformer, bus duct entrance termination box, and customer bus duct entrance box on the same monolithic pad to avoid soil settlement issues. See [Document 043818](#) or [Document 045292](#) for transformer pad dimensions.

6. Service Connection

The customer must provide a minimum of 36 inches of straight (unbent) bus duct from the bus duct entrance terminating end at the side of the pad-mounted transformer (top entry is not permitted). The customer must also supply tie straps for collecting like phases, all necessary bus extensions, and bracing for bus extensions, as required. The bus duct must enter the transformer entrance box in a "horizontal" configuration. PG&E will make the connections from the bus extensions to the transformer secondary terminals, using insulated, flexible, copper conductor provided by PG&E.

7. A termination enclosure is allowed if its installation meets the following requirements:

- A. Has the same capacity and short circuit rating as the customer's switchboard.
- B. Installed at a distance no closer than 60" from the edge of the transformer pad.
- C. Meets Greenbook specifications as listed below:
  - 5.2.1. Approved Metering and Service Termination Equipment.
  - 5.2.2. Drawing Submittal Requirements for Metering and Service Termination Equipment.
  - 9.10. Underground Service Cable–Termination Section or Pull Box.
  - Table 9 – 4 Minimum Pad–Mounted (Floor–Standing) Switchboard Pull–Section Dimensions: Residential and Nonresidential, Single–Phase and Three–Phase.
  - Figure 9 – 15, Detail of Aluminum, Termination Bus Stubs.
  - 10.3.12. Service Terminations for Underground Services.
  - 10.3.14. Underground, Cable–Terminating Facilities in Pull Boxes or Pull Sections.

8. To provide a water tight transition between the components, the bus duct (flanged ends provided by the customer) must match the dimensions of the transition box assembly and flange plate (Detail A on Page 9).

9. Transformer Bus Duct Cover Plate

A cover used to close off the bus duct entrance hole left in a transformer when it is removed or replaced. This plate bolts into the same bolt holes used for the bus duct entrance termination box and can be installed locally so that the transformer can be reused without sending it to Emeryville to have the opening covered (Code 180203).

References	Location	Document
<a href="#">Connectors for Insulated Cables Underground Distribution Systems</a>	UG-1: Connectors/Greenbook	015251
<a href="#">Concrete Pads for Radial-Style, Three-Phase Pad-Mounted Transformers</a>	UG-1: Transformers	043818
<a href="#">Installation of Loop-Style, Three-Phase, Pad-Mounted Transformers</a>	UG-1: Transformers	045291
<a href="#">Concrete Pad for Three-Phase, Loop-Style, Pad-Mounted Transformers</a>	UG-1: Transformers/Greenbook	045292
<a href="#">Terminating Underground Electric Services 0–600 Volts in Customer-Owned Facilities</a>	UG-1: Services/Greenbook	058817
<a href="#">Methods and Requirements for Installing Commercial Underground Electric Services 0-600 Volts to Customer-Owned Facilities</a>	UG-1: Services/Greenbook	063928

Filed in Cal. Rest. Ass'n v. City of Berkeley  
No. 21-16278 am archived December 27, 2023

## Requirements for Bus Duct Entrance Termination Unit for Use With Pad-Mounted Transformers

### Installation

#### Notes

1. Method of installation (see Figure 1 on Page 4) - The location of the edge of the pad must first be established by consultation between PG&E and the building architect or contractor. The bus duct termination end flange and flange plate must be located such as to permit its connection to the bus duct entrance termination box at a point 23 inches to 24 inches from the edge of the pad. The vertical centerline of the bus duct entrance termination box must be located 23 inches from the front edge of the transformer pad (see Figure 1, Section A-A and Figure 2, Section B-B on Page 4). Additionally, there must be a minimum of 60 inches straight length between the edge of the pad and any obstruction (bend, support, apparatus, wall or building, etc) in the bus duct to accommodate the 48" long bus duct entrance termination box provided by PG&E.

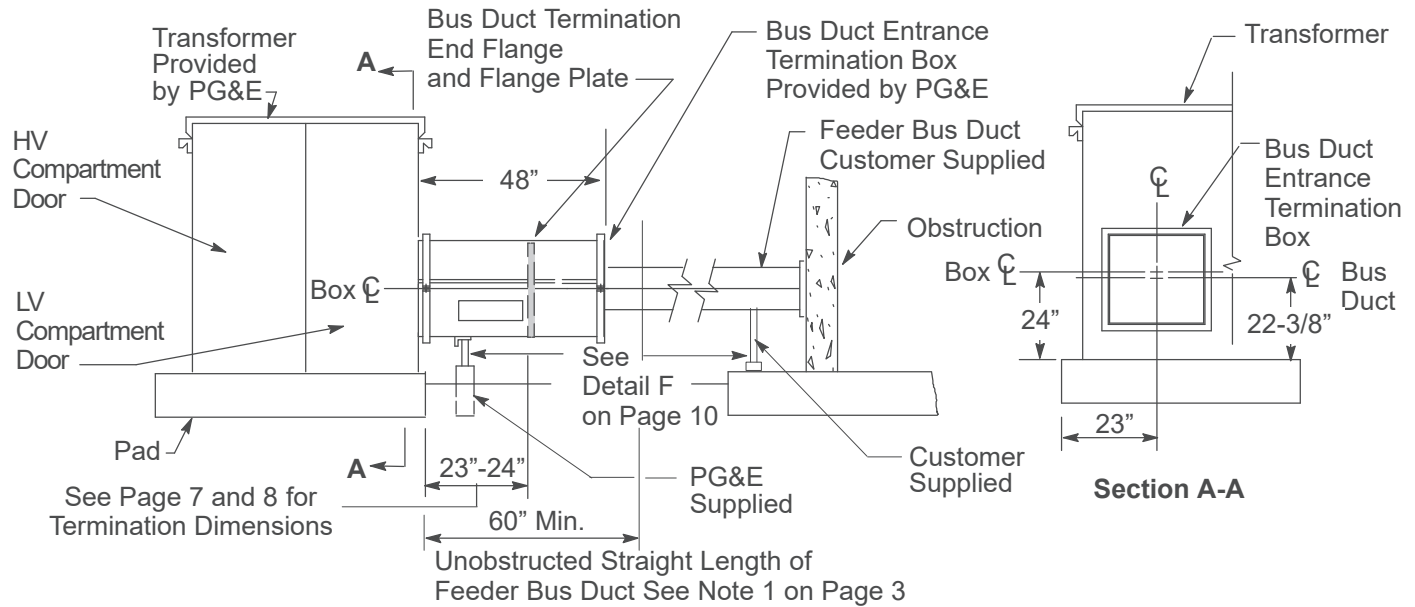
These dimensions will accommodate all style IIB, IIC, IIE, IIF, IIG, and IIH transformers used in bus applications.

2. Bus duct flange plate (see Detail A on Page 9) - A removable bus duct end flange plate must be provided by the customer at the transformer end of the bus duct. This plate must not be drilled. PG&E will locate and drill 1/2-inch diameter holes in the flange plate to match the square holes in the adjustable end flange of the entrance box.
3. Transformer cabinet bus duct cutout - The horizontal centerline of the bus duct termination box in the side of the transformer must be approximately 24 inches above the top of the pad. The cutout dimensions and drilling for bolt holes must match the dimensions and drilling of the entrance box, as determined in the field. A template is provided in the kit to help in positioning the flanged end and locating the mounting holes.
4. Bus duct connections in transformer (see Figure 3 on Page 5)
  - A. For two and three bars per phase, the customer must provide tie straps bolted across like phases where they enter the transformer entrance box.
  - B. PG&E will provide the flexible copper conductor and spade connectors necessary to make the connection between the secondary spades of the transformer and the customer's bus duct.
  - C. The customer must furnish the tie bars (Section F-F on Page 9) and spacers (Detail D on Page 9) with the bus duct. The bus duct must be in a horizontal configuration when entering the entrance box.
  - D. PG&E will provide the necessary spade supports for the protection of the transformer. See [Document 045291](#) for further information on the secondary cable support kit (M019644).
5. Feeder bus duct and entrance box supports - Feeder bus duct supports (where necessary) are required to be installed by the customer. The entrance box must not be used as a bus duct support. PG&E will provide and install a support (supports are not part of a kit) for the bus duct entrance termination box, as shown in Figure 1 and Figure 2 on Page 4, and Detail F on Page 10.

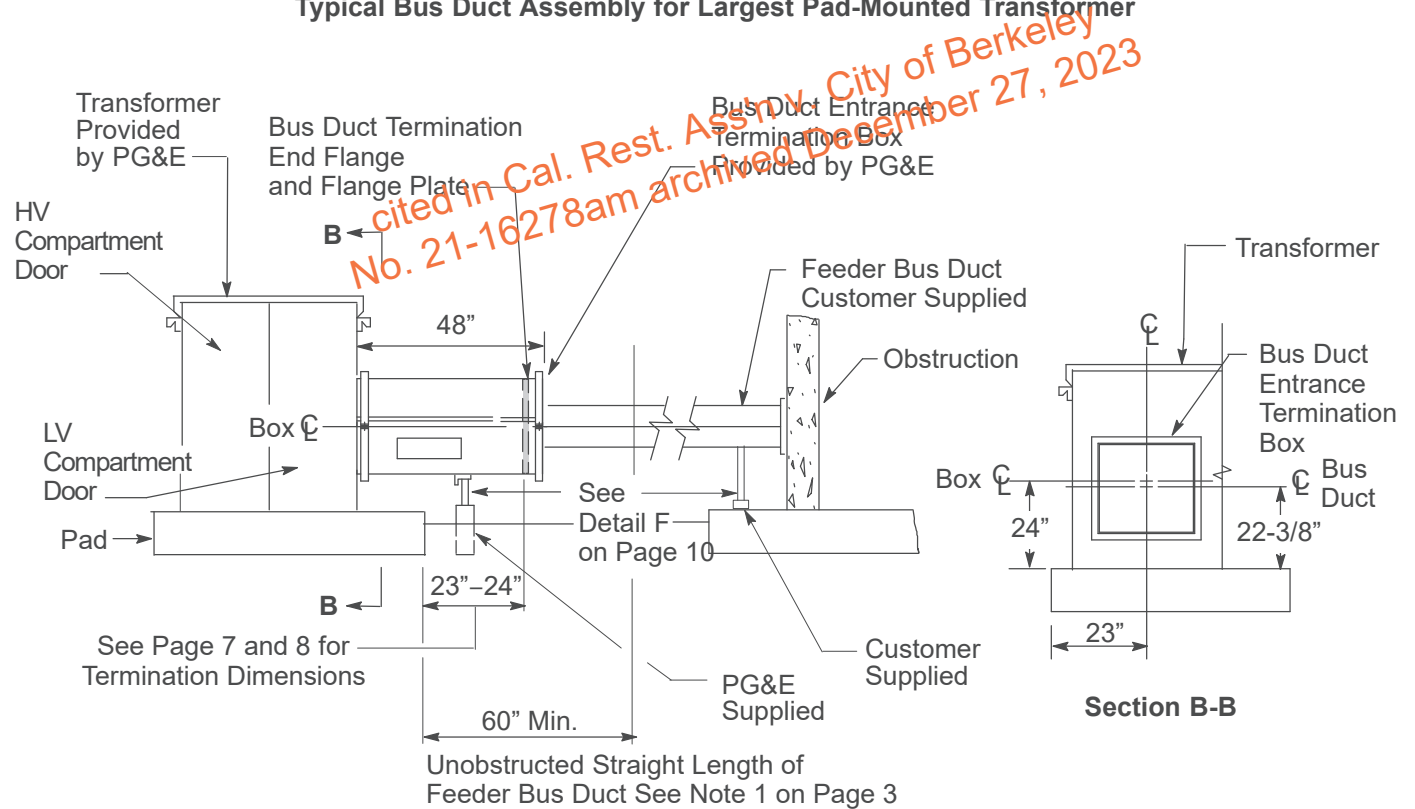


### Requirements for Bus Duct Entrance Termination Unit for Use With Pad-Mounted Transformers

#### Installation (continued)



**Figure 1**  
**Typical Bus Duct Assembly for Largest Pad-Mounted Transformer**

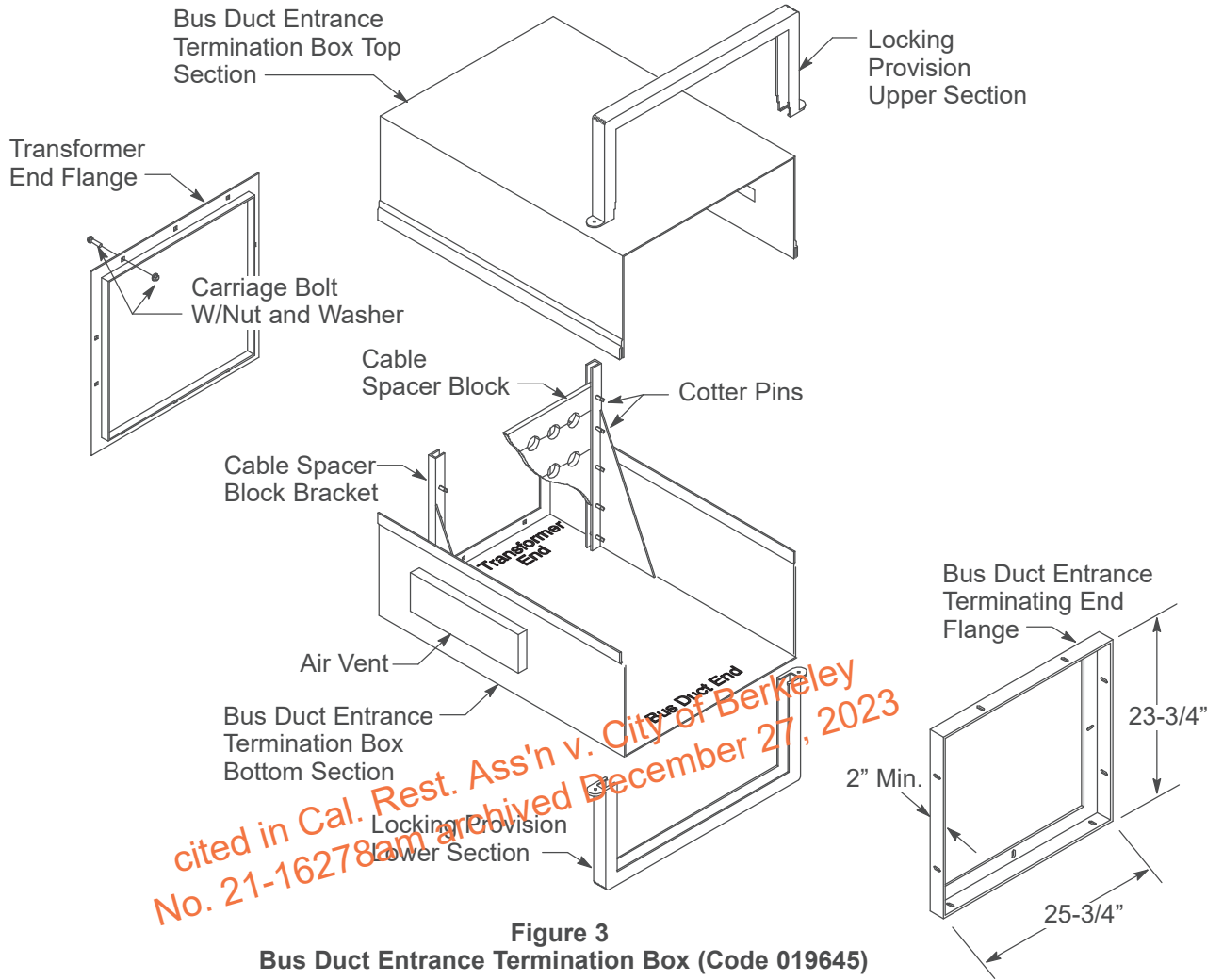


**Figure 2**  
**Typical Bus Assembly for Smallest Pad-Mounted Transformer**

Note: Dimensions in all Figures are not to scale.

**Requirements for Bus Duct Entrance Termination Unit  
 for Use With Pad-Mounted Transformers**

**Bus Duct Entrance Termination Box Assembly**



**Figure 3  
 Bus Duct Entrance Termination Box (Code 019645)**

**Table 1 List of Material for Bus Duct Entrance Termination Box Kit <sup>1</sup>**

Quantity	Description
1	Stainless Steel Bus Duct Entrance Termination Box
1	Cable Spacer
4	Copper Bus Bar Extensions <sup>2</sup> (see Detail E on Page 10)
24	1" x 3/8" Carriage Bolts With Nuts and Washers
2	3/8" x 3-1/2" Bolt, With Nut and 3/16" Diameter Hole for Safety Lock
2	Safety Locks, Utilco Catalog Number PEL-1, Code 170115
10-Foot Length	Weather Stripping
1	Template

<sup>1</sup> When needed, use and order secondary cable support kit M019644 (see [Document 045291](#)). This kit is not included in the bus duct termination box kit.

<sup>2</sup> See Page 6 for additional information on copper bus bar extensions.

### Requirements for Bus Duct Entrance Termination Unit for Use With Pad-Mounted Transformers

#### **Bus Duct Entrance Termination Box Assembly (continued)**

Copper bus bar extensions are available as a component of the bus duct entrance termination box kit (Code M019645), and can also be ordered separately. (Code M310028).

The copper bus bar extensions are used when additional secondary cable is added to the transformer and the terminal spades do not have enough room to accommodate the additional cable.

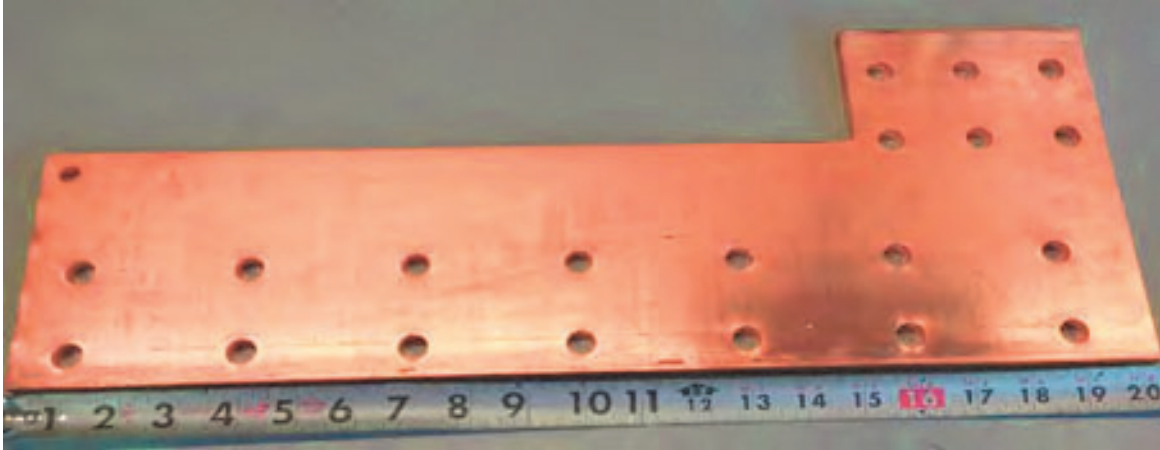


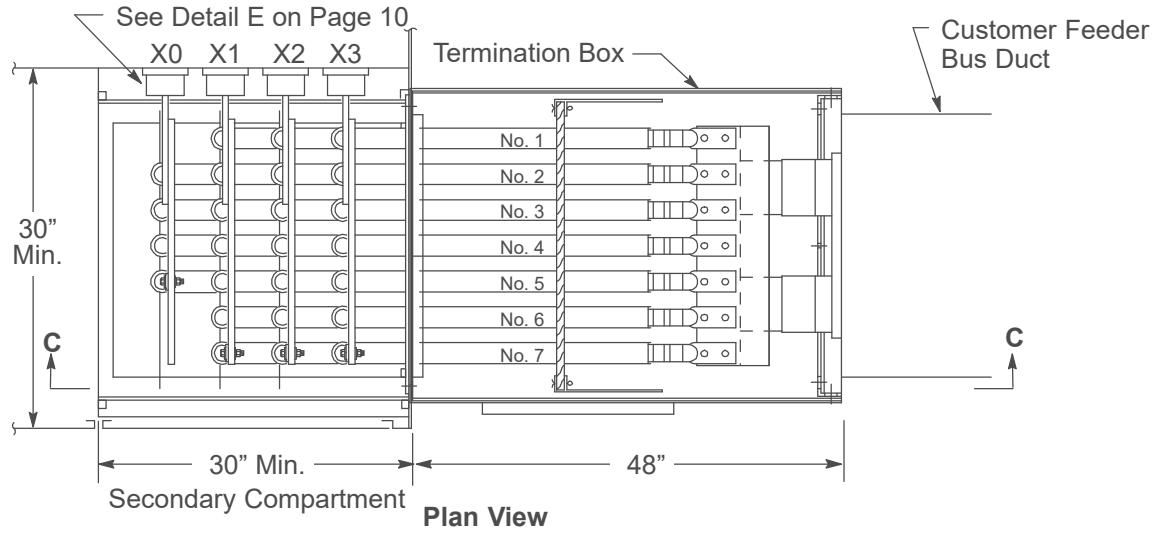
Figure 4  
Copper Bus Bar Extension

Table 2 Recommended Tools for Assembly and Installation of Bus Duct Entrance Termination Box

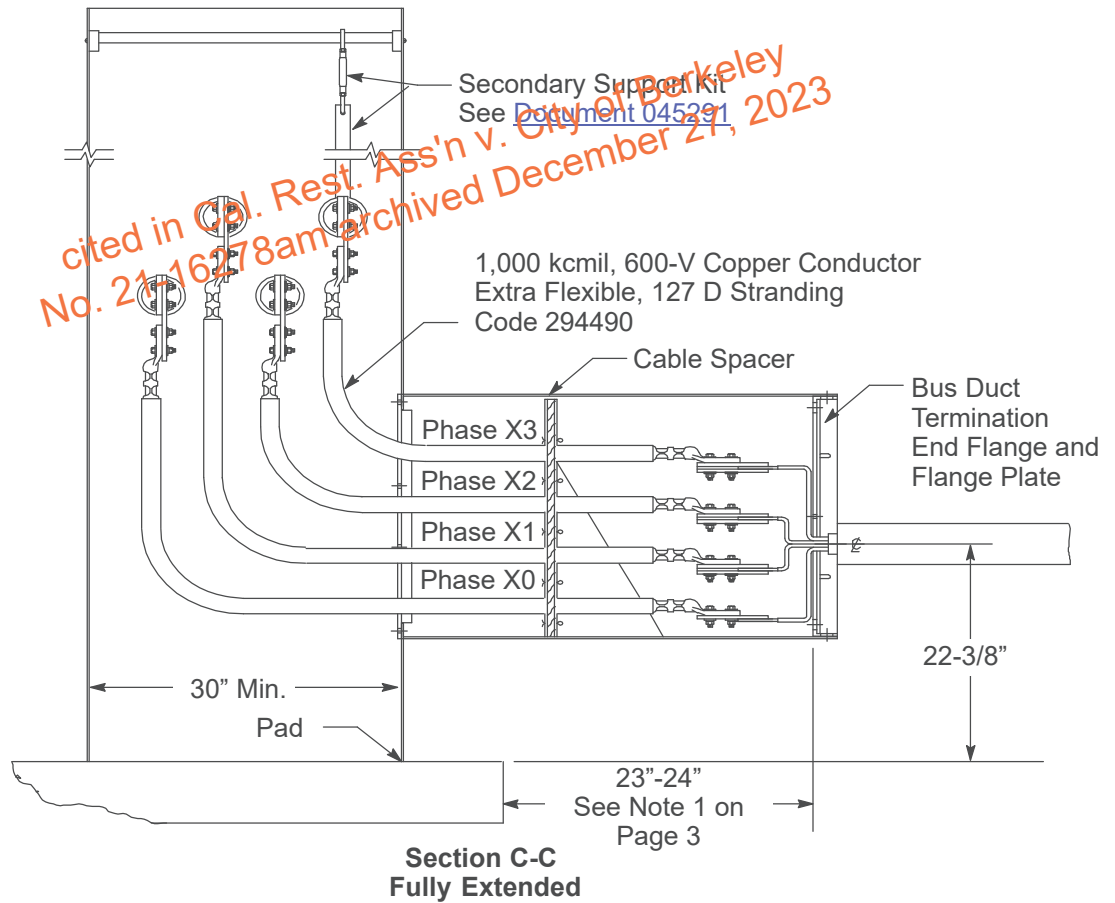
Description	Code
Sawzall, Heavy Duty, Milwaukee #6511-W/Case	210075
Blades, Sawzall, Milwaukee #48-00-0171 - Package of 10	207674
Drill, Skil #6550, 1/2" Variable Speed Reversible	210026
Drill Bit Set, 1/16" to 1/2", W/Case	203026
Punch, Center, 3/8"	201305

**Requirements for Bus Duct Entrance Termination Unit  
 for Use With Pad-Mounted Transformers**

**Bus Duct Termination Assembly – Fully Extended**



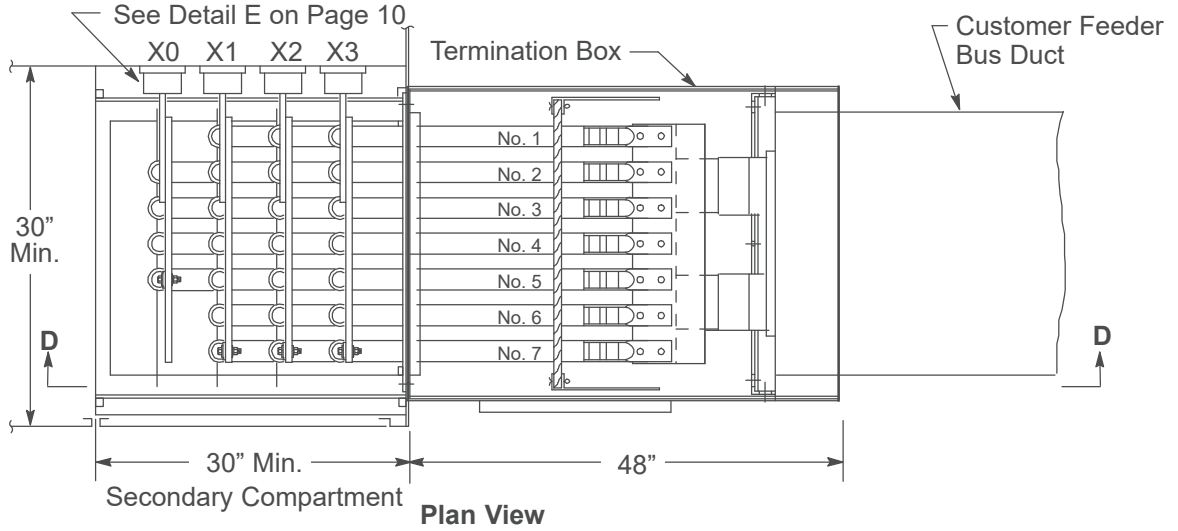
**Typical Outdoor Bus Termination Fully Extended**



**Figure 5  
 Bus Duct Termination Assembly Fully Extended**

### Requirements for Bus Duct Entrance Termination Unit for Use With Pad-Mounted Transformers

#### Bus Duct Termination Assembly – Fully Compressed



Typical Outdoor Bus Termination Fully Compressed

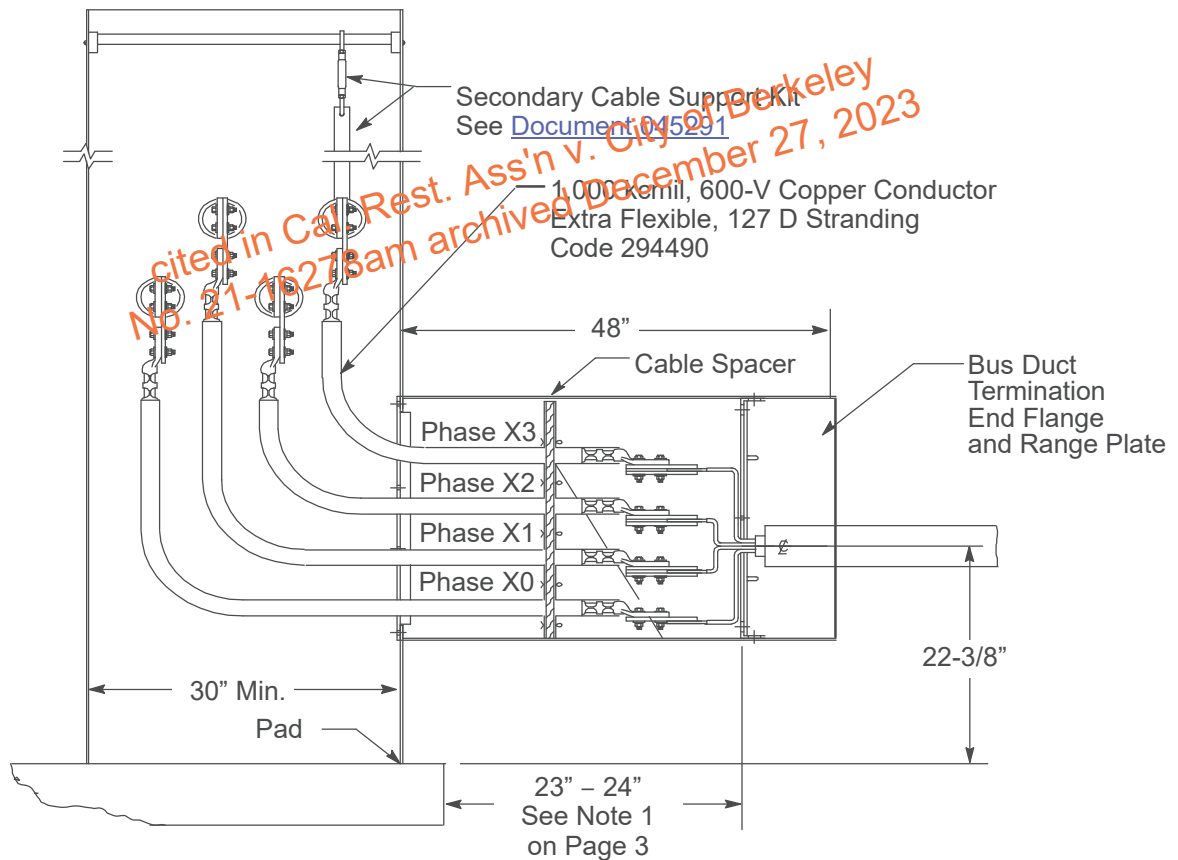
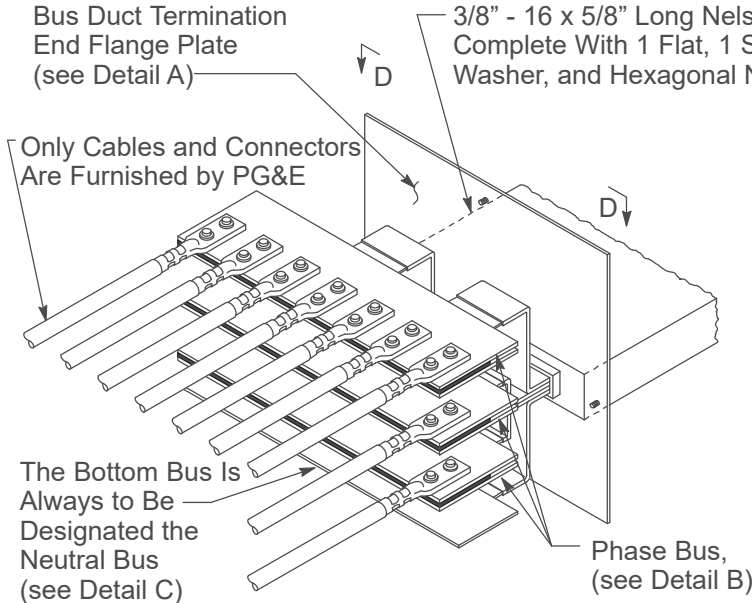


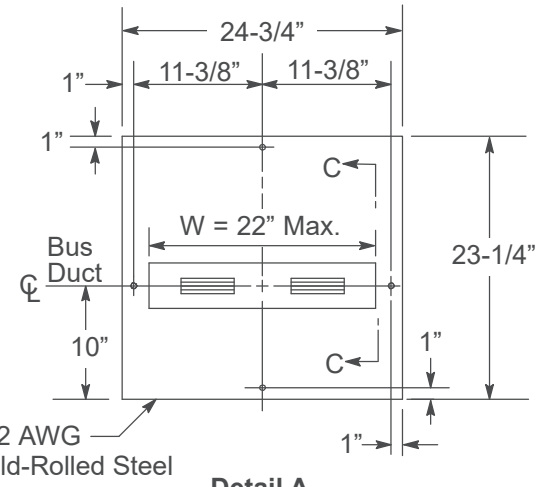
Figure 6  
Bus Duct Termination Assembly Fully Compressed

**Requirements for Bus Duct Entrance Termination Unit  
 for Use With Pad-Mounted Transformers**

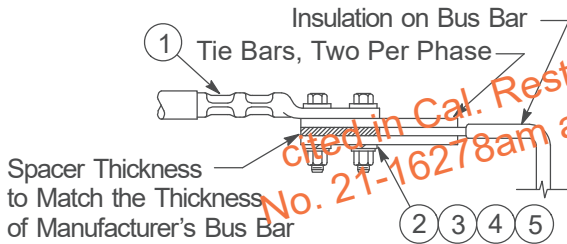
**Bus Duct Termination Assembly – Details**



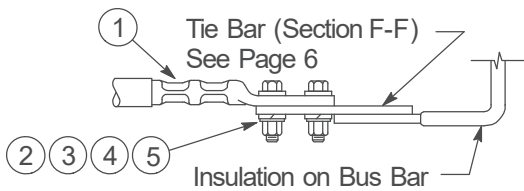
**Figure 7  
 Termination Detail With  
 Bus Duct End and Tie Bars**



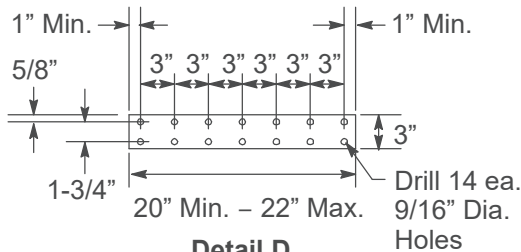
**Detail A  
 End Flange Plate  
 (customer supplied)**



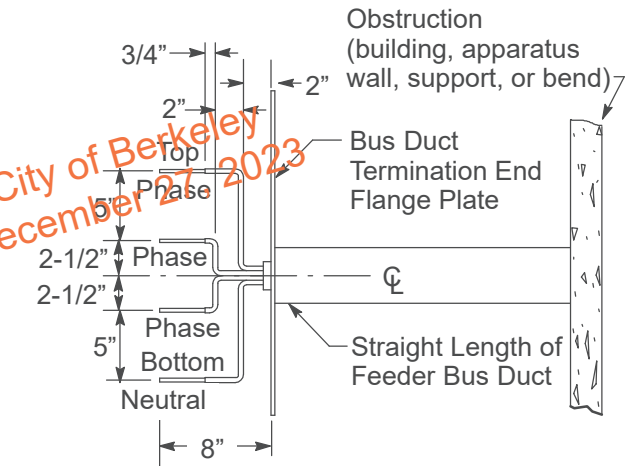
**Detail B  
 Typical Phase Bus Termination Assembly**



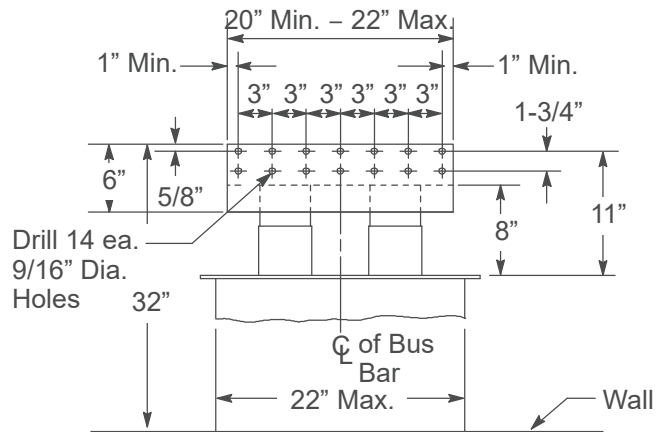
**Detail C  
 Typical Neutral Bus Termination Assembly**



**Detail D  
 Spacer 3" x 20" Long Copper  
 (thickness to suit)  
 (customer supplied)**



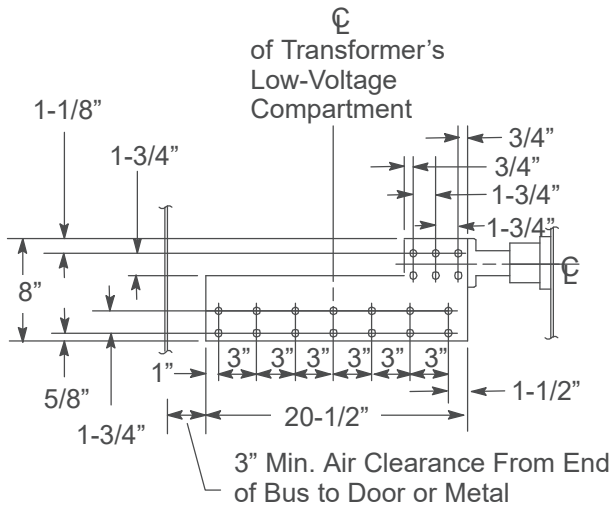
**Section E-E  
 Bus Bar  
 (customer supplied)**



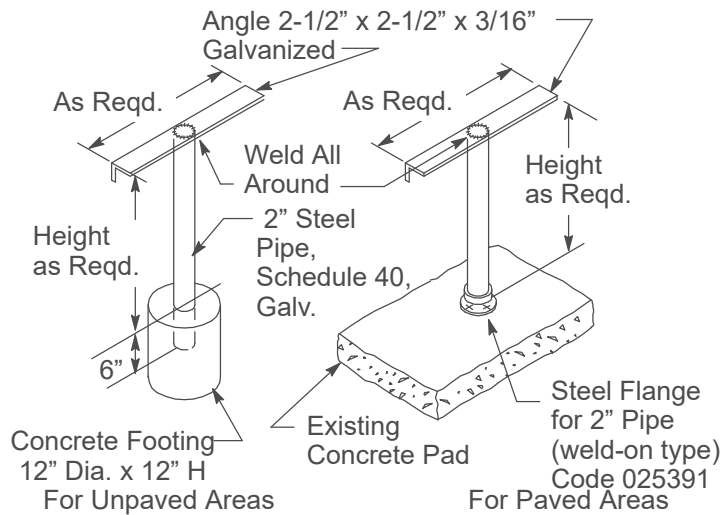
**Section F-F  
 Tie Bar Connection 1/4" x 6" x 20" Long Copper  
 (two per phase and one per neutral required)  
 (customer supplied)**

### Requirements for Bus Duct Entrance Termination Unit for Use With Pad-Mounted Transformers

#### Bus Duct Termination Assembly – Details (continued)



**Detail E**  
Copper Bus Bar Extension  
(see Table 1 on Page 5)



**Detail F**  
Termination Unit Supports  
(PG&E supplies one under the bus duct termination box. Customer supplies remainder as required.)

**Table 3 Copper Conductor Requirements<sup>3</sup>**

Main Switch Rating	Number of Conductors Per Phase	Number of Neutral Cables	Approximate Footage of Conductor
2,500	4	2	140
3,000	5	3	180
3,500	6	3	210
4,000	7	4	250

<sup>3</sup> Use only 1,000 kcmil copper cable (Code 294490).

**Table 4 List of Materials for Bus Termination Assemblies (see Detail B and Detail C on Page 9)**



Item	Description	Code	Document
1	Terminal Connector, Compression-Type, Cable-to-Flat, for 1,000 kcmil Cable	303461	<a href="#">015251</a>
2	Screw, Cap (bolt), Hex. Head, 1/2" x 2-1/2", Everdur or Equivalent	193177	-
3	Nut, Bolt, Hex., 1/2", Everdur or Equivalent	195013	-
4	Washer, Round, 1/2", Everdur or Equivalent	195252	-
5	Washer, Lock, 1/2", Everdur or Equivalent	195193	-

#### Revision Notes

Revision 12 has the following changes:

1. Revised Notes 2E and 3B on Page 1.
2. Updated Reference links to TIL Viewer.
3. Delete the word joint in Note 1 on Page 3.
4. Added Notes 1 and 2 and Figure 4 on Page 6.
5. Replace the word shall with must throughout document.

Prepared by: ABB1

	<b>BOX-PAD FOR PAD-MOUNTED TRANSFORMERS</b>	<b>064309</b>
<b>Asset Type:</b> Distribution		<b>Function:</b> Design
<b>Issued by:</b> Michael Thibault (MLTC)		<b>Date:</b> 12-01-19
<b>Rev. #10:</b> This document replaces PG&E Document 064309, Rev. #09. For a description of the changes, see Page 7.		

**This document is also included in the following manual:**

- [Electric and Gas Service Requirements Manual](#) (Greenbook)

**Purpose and Scope**

This document shows the requirements for the box-pad used with single-phase Style DF (see [Document 064307](#)), duplex, and three-phase Style MTP (see [Document 045290](#)) transformers. This document applies to both radial and looped primary circuit arrangements.

**Applicant Notes**

1. Prior to setting a pad, the applicant will request an inspection by PG&E. PG&E shall determine the acceptability of each pad installation. The pad installation includes two ground rods and the interconnecting ground wire.
2. If required, the applicant shall provide suitable barriers for the protection of the transformer (refer to [Document 051122](#)).
3. The pads must be made by a PG&E-approved supplier. The approved suppliers are listed in [Document 066211](#).

**Fabrication Requirements**

4. Box-pads are designed to fully encompass the transformer, including any radiators. Each pad shall hold the full kVA range of the indicated style. The pad dimensions are based on the allowed transformer dimensions shown in [Document 064307](#).
5. The pads shall be permanently identified with manufacturer's name, month and year of fabrication, nominal weight, and PG&E code number in the area indicated in Figure 1 on Page 4.
6. The pads shall conform to [Engineering Material Specification 21 "Box-Pad Style Transformer Pads"](#)
7. The pads shall be designed to support transformers weighing 3,000 pounds.
8. Two 1/2"-13 UNC inserts for securing the transformer cabinet shall be provided as indicated. One 5/8"-11 UNC insert shall be provided at the center of gravity for lifting the pad.
9. The inserts shall be installed flush with the surface of the pad.
10. The edges shall be rounded. Refer to [Engineering Material Specification 21 "Box-Pad Style Transformer Pads"](#)
11. The corners may be rounded. Refer to [Engineering Material Specification 21 "Box-Pad Style Transformer Pads"](#).

**Installation Requirements**

12. The transformer pad shall be placed on a firm 10-inch rock base, on top of native or engineered fill material, which has been compacted to at least the requirements of Note 15 on Page 2.
13. The area under the pad shall be excavated to the required grade, or to a depth necessary to reach firm, undisturbed material, whichever is deeper. The material may be considered firm if it cannot be penetrated by thumb except with moderate effort.
14. If firm material has not been reached within a depth of 3 feet, excavate 3 feet beyond the perimeter of the pad, and backfill the entire excavated area to the required grade and to the requirements of Note 15 on Page 2.



**Box-Pad For Pad-Mounted Transformers**

15. In case it is necessary to excavate deeper than the required grade to reach firm material, backfill to the required grade in one of the following ways:
- Backfill with clean, non-expansive soil compacted to 90% of maximum density. The soil shall be placed in layers not more than 8 inches thick before compaction. Determine the maximum density and the in-place density by the [California Test Method No. 216-6, Parts I and II](#) respectively, or by [ASTM D-1556](#) and [D-1557](#) respectively. A copy of the test results may be required by PG&E.
  - Backfill with soil or cement slurry consisting of one sack of Portland cement per cubic yard and clean native soil or sand.
16. In areas of known soft soil conditions, trenches within the pad excavation area for the installation of conduits shall be backfilled in one of the ways specified in Note 15.
17. In addition to the above requirements, the pads shall be placed on a 10-inch level rock base to provide uniform bearing.
18. A minimum distance of 6 feet shall be maintained between the ground rods.
19. In general, all equipment pads should be installed as level as practicable. Pads supporting oil-filled equipment must be leveled to within 1 inch in 8 feet in all directions.
20. An equipment BOX pad SHALL NOT be placed on an elevated berm, mound or structure either earthen or otherwise when placed in a Flood Plain. If local knowledge of the area in which the equipment is to be placed identifies a high likelihood that uninsulated terminals of the equipment will come in contact with floodwater and the location cannot be moved to a location less likely to have flood levels come in contact with the exposed terminals, a Subsurface Fully Insulated Device should be installed in lieu of the pad mount design. In some cases such as transformers, because of capacity limits of subsurface material coded equipment it may not be possible to provide a transformer of sufficient capacity to serve loads in excess of the capabilities of a 1000 kVA UCD.

**Installation Procedure**

- Step 1. Excavate as required.
- Step 2. Install the exterior ground rod and run the ground wire to the pad excavation.
- Step 3. Place the primary conduit bends into the pad excavation.
- Step 4. Place the secondary and the service conduit into the pad excavation.
- Step 5. Compact and install the rock base. See "Installation Requirements", Notes 15, 16, and 17.
- Step 6. The exposed ends of the conduit bends should be about 1 inch above the gravel base.
- Step 7. Install end bell fittings.
- Step 8. Temporarily cap or plug all the conduits.
- Step 9. Route the ground wire through the pad opening.
- Step 10. Place the box-pad and backfill to the appropriate level for the pad.
- Step 11. Install the interior ground rod.

**Table 1 Bill of Materials**

Item	Quantity	Description	Code
1	1	Box-Pad, (as required – see Table 2 on Page 4)	-
2	As Req'd.	Wire, #2 AWG, Solid Bare Copper	290074
3	2	Ground Rod, 5/8" x 8'-0", Copperclad (see <a href="#">Document 013109</a> )	187013
4	2	Clamp, Ground Rod, (see <a href="#">Document 013109</a> )	187012
5	As Req'd.	Compacted Backfill	-
6	As Req'd.	Rock Base (compact 3/4" minus the rock base)	-

**Box-Pad For Pad-Mounted Transformers**

References	Location	Document
<u>Corrosion Resistant Ground Rods and Ground Rod Clamps</u> .....	<u>UG-1: Connectors/Greenbook</u> .....	<u>013109</u>
<u>Loop-Style, Three-Phase, Pad Mounted Transformers Location, Clearances, and Mechanical Protection</u> .....	<u>UG-1: Transformers</u> .....	<u>045290</u>
<u>Details for Pad-Mounted and Subsurface Equipment</u> .....	<u>UG-1: General</u> .....	<u>051122</u>
<u>Single-Phase, Dead-Front, and Duplex, Pad-Mounted Transformer</u> .....	<u>UG-1: Transformers</u> .....	<u>064307</u>
<u>Single-Phase, Dead-Front, and Duplex, Pad-Mounted Transformer Installations</u> .....	<u>UG-1: Transformers</u> .....	<u>064308</u>
<u>PG&amp;E-Approved Electric Distribution Materials Manufacturer</u> .....	<u>Greenbook</u> .....	<u>066211</u>
<u>Engineering Material Specification No. 21 "Box-Pad Style Transformer Pads"</u> .....	<u>TIL</u> .....	<u>EMS21</u>

*cited in Cal. Rest. Ass'n v. City of Berkeley  
No. 21-16278am archived December 27, 2023*

### Box-Pad For Pad-Mounted Transformers

#### Box-pads

Table 2 Dimensions for Pad-Box

Transformer	Pad Code Number	Dimension in Inches						
		A	B	C	D	E	I	W
1-Wire, 2-Bushing Style DF-LB	360001	25	15	5.5	4	46	28	36
2-Wire, 4-Bushing Style DF-LB	360002	28	15	11	4	60	31	50
3-Wire, 6-Bushing Style DF-LB, Duplex and Style MTP	360003	37	15	6.5	4	60	40	50

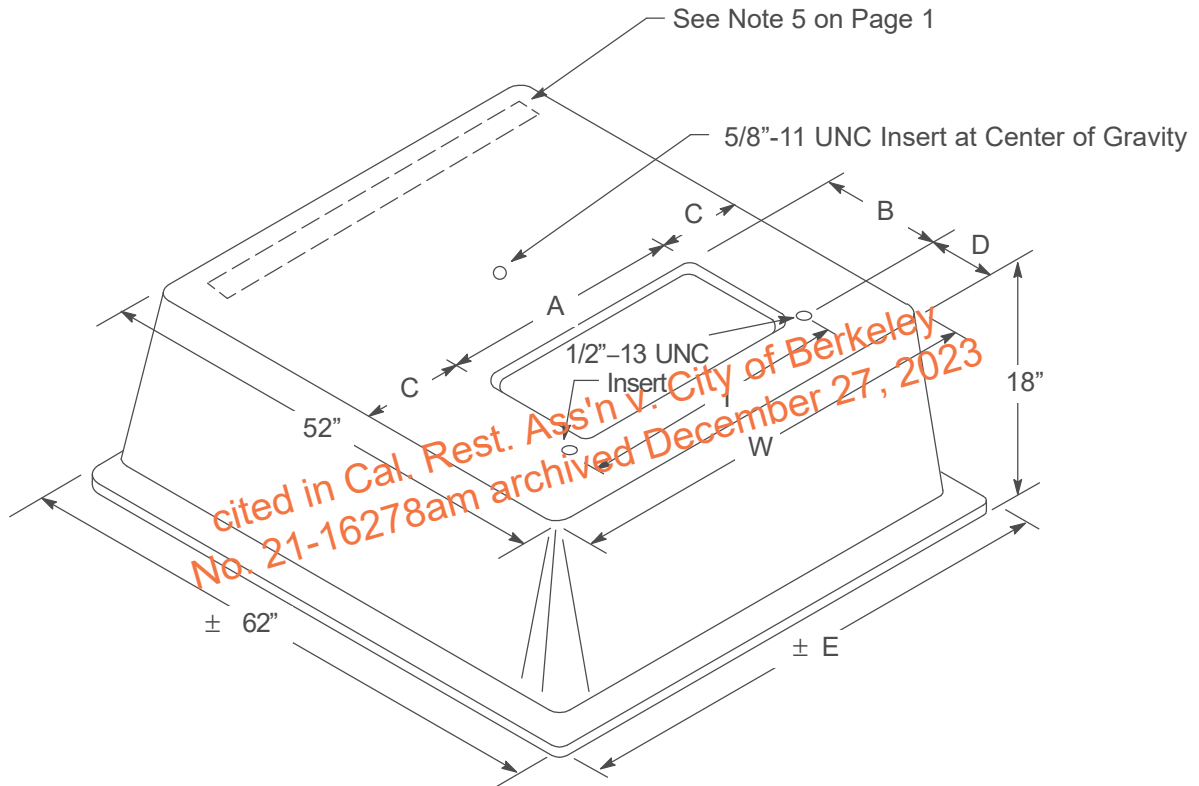
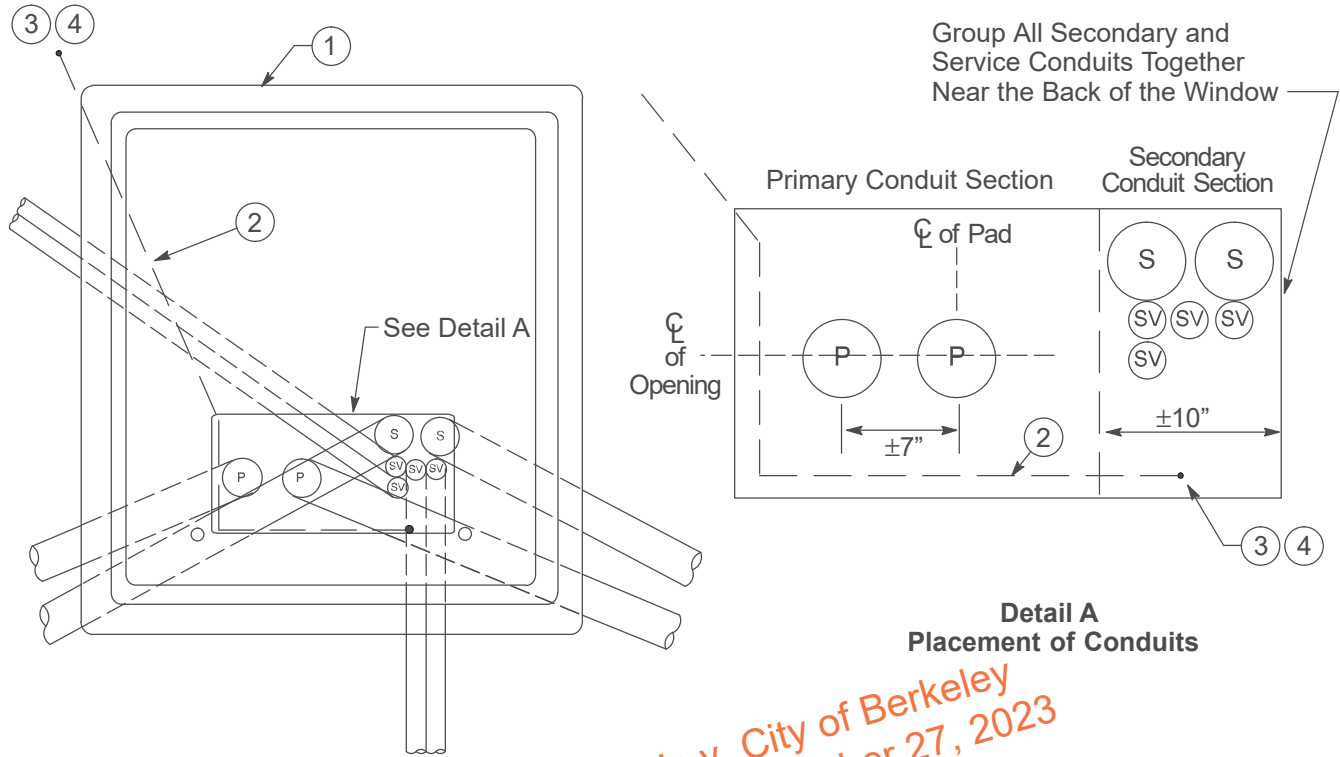


Figure 1  
Box-Pad

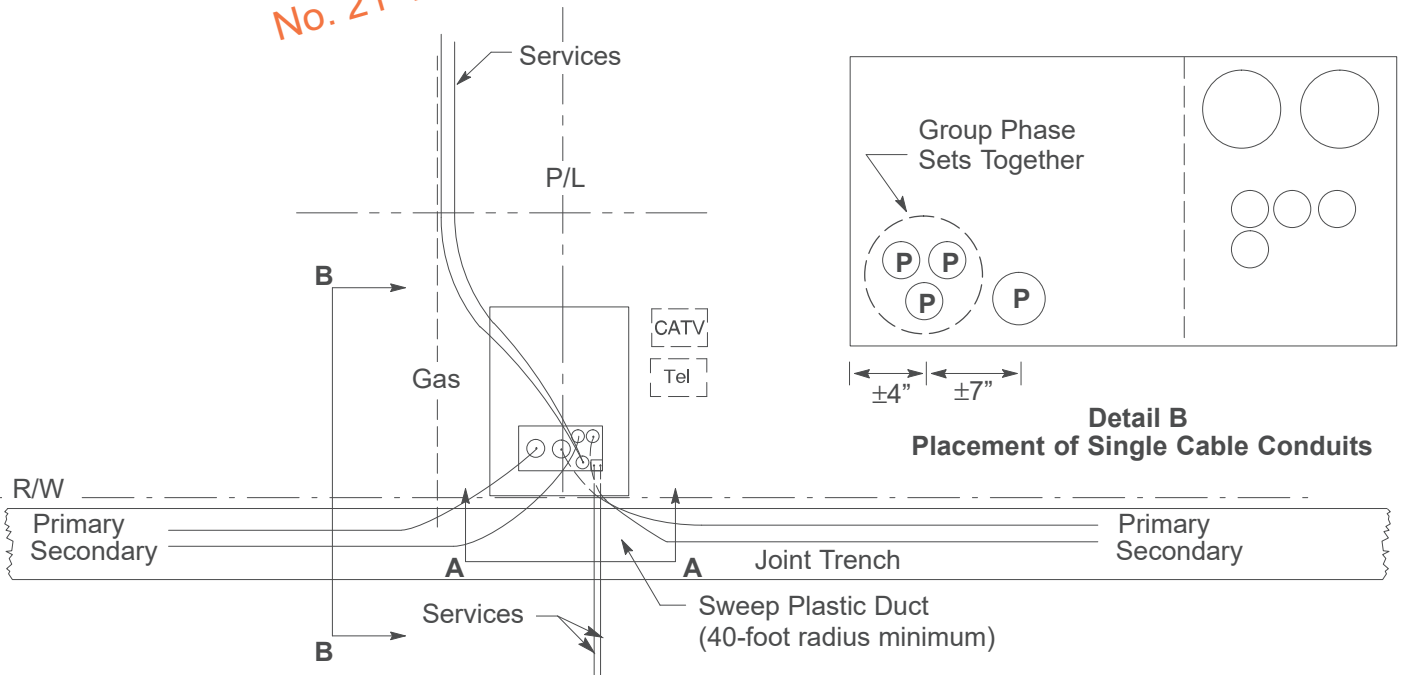
**Box-Pad For Pad-Mounted Transformers**

**Typical Box-Pad Installation**



**Figure 2**  
Pad Top View  
(50" x 52" x 18" box pad shown)

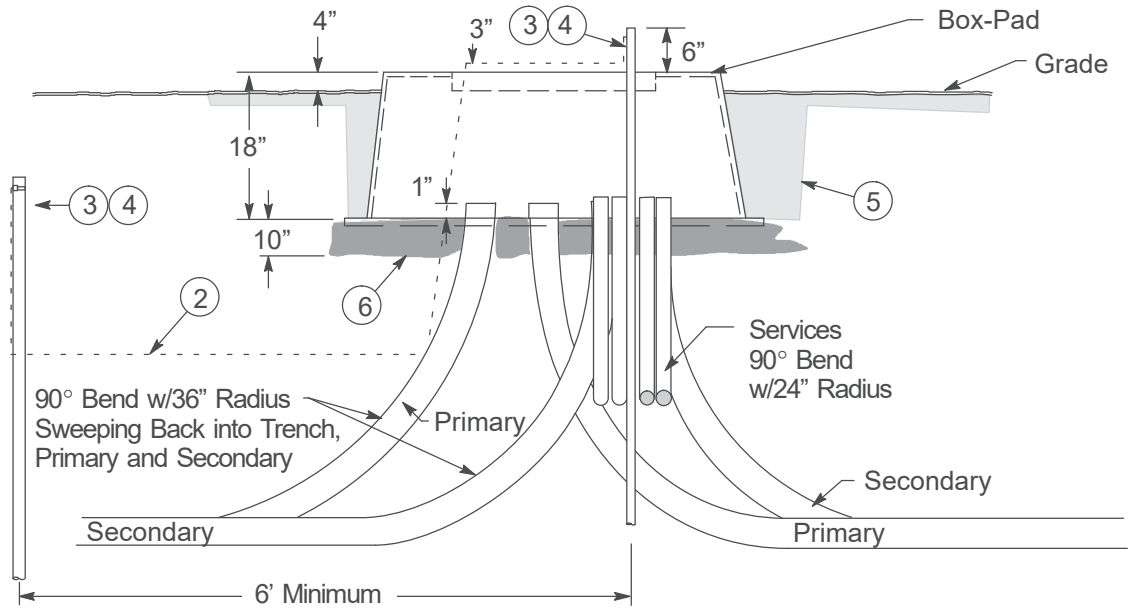
*Cal. Rest. Ass'n v. City of Berkeley  
No. 21-16278am archived December 27, 2023*



**Figure 3**  
Facilities Plan View

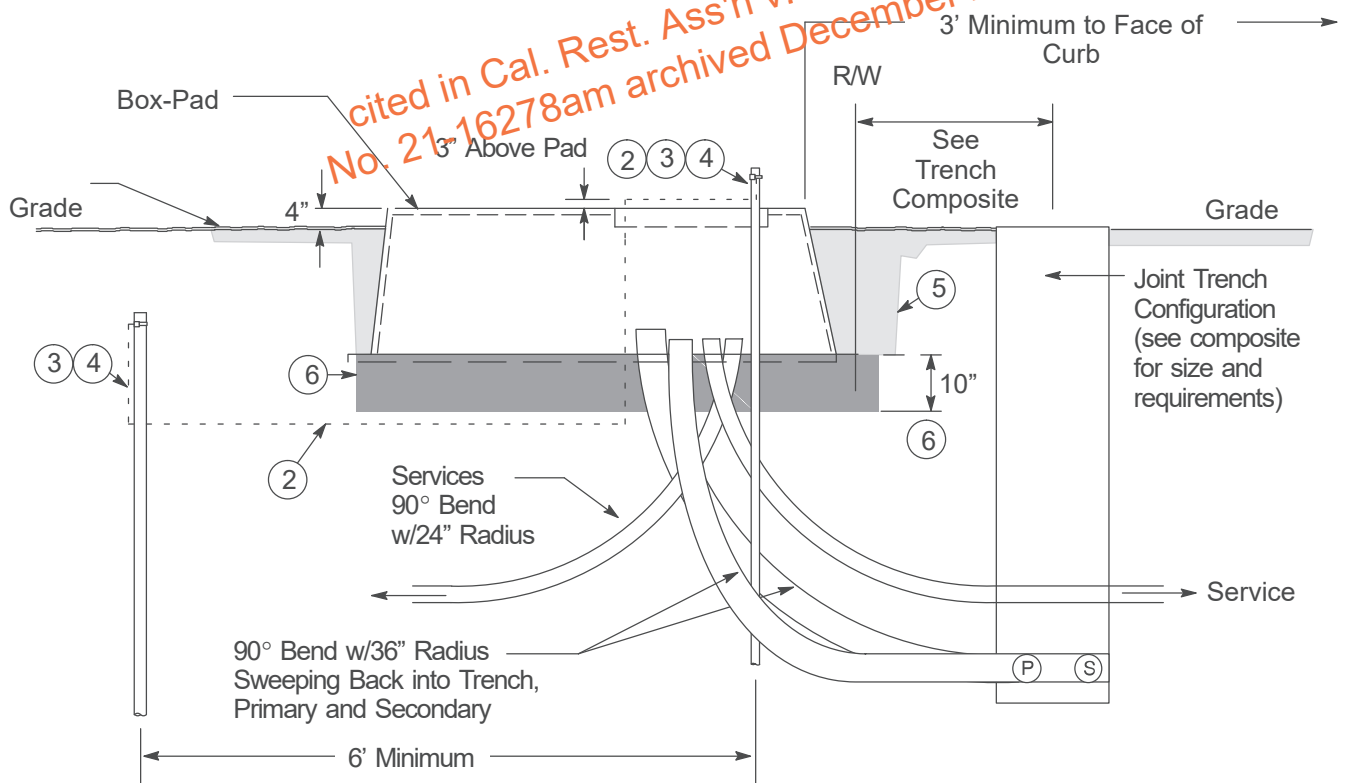
**Box-Pad For Pad-Mounted Transformers**

**Typical Box-Pad Installation (continued)**



**Section A-A  
Pad Front View**

*cited in Cal. Rest. Ass'n v. City of Berkeley  
No. 21-16278am archived December 27, 2023*



**Section B-B  
Pad Side View**

## Box-Pad For Pad-Mounted Transformers

---

This document is also found in the [Electric and Gas Service Requirements Manual](#) (Greenbook). This document has been split. See [Document 064309A](#) in the “Transformers” section of the *For Reference Only Manual (FRO)* for its remainder.

### Revision Notes



Revision 10 has the following changes:

1. Added Note 20 on Page 2.
2. Updated References on Page 3.

cited in Cal. Rest. Ass'n v. City of Berkeley  
No. 21-16278am archived December 27, 2023

cited in Cal. Rest. Ass'n v. City of Berkeley  
No. 21-16278am archived December 27, 2023

Prepared by: SXZO

	<b>OVERHEAD AND UNDERGROUND PANEL BOARD CONSTRUCTION</b>		<b>065374</b>
	<b>Asset Type:</b> Electric Metering <b>Issued by:</b> Daniel Jantz (DWJ7)		<b>Function:</b> Design <b>Date:</b> 3/25/2022
<b>Rev. #15:</b> This document replaces PG&E Document 065374, Rev. #14. For a description of the changes, see Page 9.			

**This document also is included in the following manuals:**

- [Electric and Gas Service Requirements Manual \(Greenbook\)](#)
- [Electric Meter Work Practices \(EMWP\)](#)

References	Location	Document
<a href="#">Requirements for Customer-Owned Poles</a>	<a href="#">OH: Services/Greenbook</a>	<a href="#">025055</a>
<a href="#">Location, Clearances, and Mechanical Protection</a>		
<a href="#">Details for Pad-Mounted and Subsurface Equipment</a>	<a href="#">UG-1: General/Greenbook</a>	<a href="#">051122</a>
<a href="#">Voltage Stabilizer for 480 Volt, Three-Phase, 3-Wire</a>		
<a href="#">Ungrounded Service</a>	<a href="#">OH: Meters/EMWP</a>	<a href="#">052497</a>
<a href="#">Agricultural Underground Service, 500 hp or Less</a>	<a href="#">UG-1: Services/Greenbook</a>	<a href="#">054619</a>
<a href="#">Agricultural Overhead Service, 300 hp or Less</a>	<a href="#">OH: Services/Greenbook</a>	<a href="#">058087</a>

cited in Cal. Rest. Ass'n v. City of Berkeley  
 No. 21-16278am archived December 27, 2023

**Purpose and Scope**

This document illustrates the requirements applicable to residential, commercial, and agricultural overhead or underground service installations served from PG&E's lines. This document is applicable where panel-type structures are used to mount customer-owned and installed equipment.

**General Information**

1. Construction Materials and Requirements

Ensure that all posts and panels on which the service and metering equipment are mounted meet the following minimum requirements. Equipment can be mounted to a panel, boards, or struts. See Note 5 on Page 3 for the maximum rating of service termination equipment.

A. Material Treatment and Specifications

- (1) Ensure that the surface areas on all wood posts, boards, and solid panels are pressure treated, including the sides and areas that have been cut. Any other treating process that provides an equivalent penetration and retention must be approved by PG&E. Acceptable wood preservatives are water-borne salts and pentachlorophenol. Brush application of wood preservatives is ineffective and therefore unacceptable.
- (2) Pipe posts must be galvanized rigid steel.
- (3) All metal boards or solid metal panels must be rigid steel and have a rust inhibitor applied to all surface areas.
- (4) Strut channels, fittings, and associated hardware must be stainless steel or galvanized steel.



## Overhead and Underground Panel Board Construction

### General Information (continued)

#### B. Material Dimensions

- (1) Structure: All structures must be a minimum length of 48 inches. For structures up to 72 inches long, the minimum combined height of the boards, panel, or struts must be 36 inches. For structures up to 96 inches long, the minimum combined height of the boards, panel, or struts must be 42 inches. For structures with lengths greater than 96 inches, use additional posts. The top of the structure must not exceed 84 inches high from the ground. There must be a minimum of 6 inches of clearance between the ground and all equipment, panels, boards, or struts.
- (2) Boards: Place side by side.
  - (a) Wood: Minimum 2 inches thick by 12 inches wide (nominal).
  - (b) Metal: Minimum 1/2 inch thick by 12 inches wide.
- (3) Panel: One solid sheet.
  - (a) Wood: 1 inch thick.
  - (b) Metal: 1/4 inch thick.
- (4) Unistrut: At a minimum, two struts are needed to support each piece of service and metering equipment. It is recommended that one strut be attached towards the top and one strut be attached towards the bottom of the equipment. Add struts for additional equipment with different length dimensions. Use struts with or without boards or panels.
  - (a) Strut channel dimensions must be a minimum 1-1/2 inch x 1-1/2 inch. See Figure 10 on Page 8.
- (5) Posts: Use a minimum of two posts to support panel-type construction. Add more posts if the construction exceeds the structural dimensions listed in Note 1B(1) on Page 1. If applicable, a PG&E-approved, customer-owned pole can be used as one of the posts. The customer-owned pole must be installed in accordance with [Document 025055](#) and the panel board must be attached to the poles as shown in Figures 8 on Page 5 and Figure 10 on Page 8.
  - (a) Wood: Solid.
    - (i) Square, 6 inches by 6 inches cross section.
    - (ii) Round, 8 inches in diameter.
  - (b) Metal: Solid or hollow. If hollow a permanent post cap is required.
    - (i) Square, 3 inches by 3 inches cross section.
    - (ii) Round, 3 inches in diameter.

#### C. Footing and Support

- (1) Place all posts in the center of a 12 inches minimum diameter concrete footing. Extend the footing a minimum of 36 inches into the ground (excluding gravel bedding), a minimum of 4 inches above ground level, and have a 1/2 inch slope away from the post to allow for drainage.

#### D. Fasteners

- (1) For wood posts, use minimum 3/8 inch x 5 inches lag screws.
- (2) For metal posts, use 3/8 inch minimum through bolts with nuts and washers.
- (3) For Unistrut, use approved fasteners and hardware made for the strut channels. This should include through bolts with nuts and washers.

#### E. Screw Holes or Openings

- (1) All unused or exposed screw holes and openings must be tightly secured by plugging or filling the entire hole with screws, bolts, or other type of metal fasteners. Sealants can be used along with the screws, bolts, and other metal fasteners.

#### F. Clearances and Barrier Posts (see [Document 051122](#))

- (1) A minimum 36 inches of clear and level working space must be maintained in front of the panel board structure at all times.

**Overhead and Underground Panel Board Construction**

- (2) If any part of the panel board structure is located within 36 inches of a thoroughfare or road, then install barrier posts. If the thoroughfare or road has high vehicular traffic and the panel board structure is less than 108 inches (9 feet) away, then install barrier posts.
- (3) The panel board and customer owned pole (if installed) must not be located less than 10 feet from the surface of the PG&E pole or within 10 feet of the vertical plane of a PG&E line.

**2. Grounding**

The customer is responsible for bonding and grounding metering and service termination equipment enclosures. See the requirements in Greenbook Section 5.8. Grounding, including Figures 5–15 and 5–16. Also Ground and bond in accordance with the National Electrical Code (NEC) and local ordinances. PG&E prefers, but does not require, the grounding electrode conductor wire to be protected against physical damage by rigid steel conduit or armored cladding

3. A voltage stabilizer for 3-wire service will be furnished and installed by PG&E (see [Document 052497](#)).
4. Properly identify and mark meters as described in Section 5.5.1 on Page 5-10 of the [Electric and Gas Service Requirements Manual \(Greenbook\)](#).
5. Termination or metering equipment with an ampacity rating greater than 400 amps, 3-phase or 600 amps, 1-phase must be pad-mounted (free standing). Refer to [Electric and Gas Service Requirements Manual \(Greenbook\)](#), Section 9.10.
6. The minimum meter height for electric panels with current transformers (CT's) is 60 inches as measured from final grade to the center of the meter. The maximum meter height is 75 inches.
7. Enclosure: For services greater than 100 feet install a pull box between 30 feet maximum and six feet minimum away from the Panelboard. See document [028028](#) Secondary Electric Underground Enclosures for the required minimum size enclosure to install.

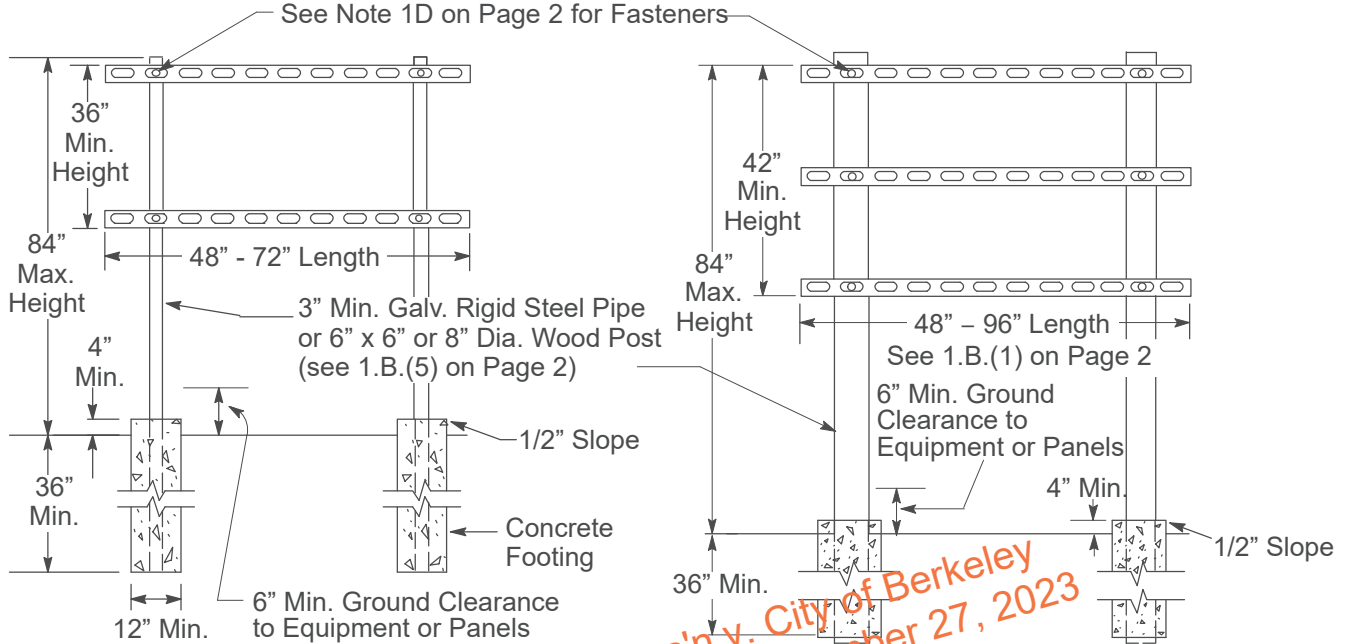
cited in Cal. Rest. Ass'n v. City of Berkeley  
No. 21-16278am archived December 27, 2023

# Overhead and Underground Panel Board Construction

## Typical Panel Board Construction

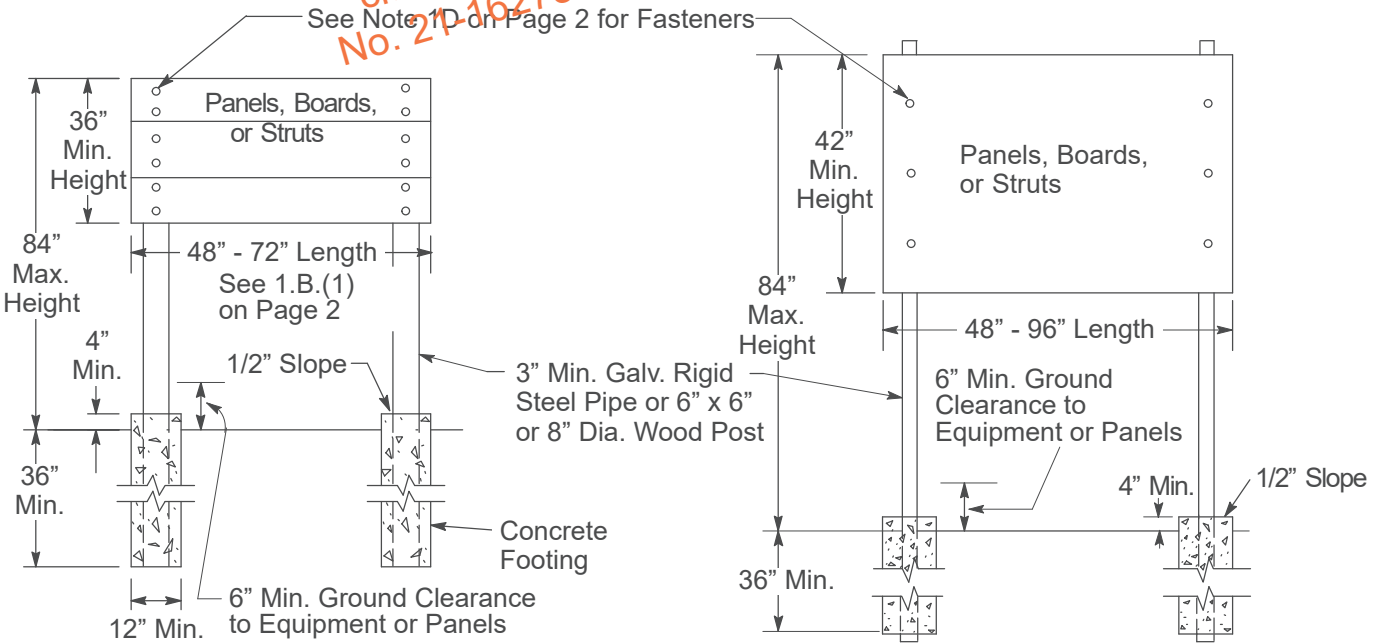
### Notes

1. See Table 1 on Page 8 for the material list.
2. Item 2 may be replaced by Items 1 and 3.



**Figure 1**  
Panel Board Construction With Struts

**Figure 2**  
Large Panel Board Construction With Struts

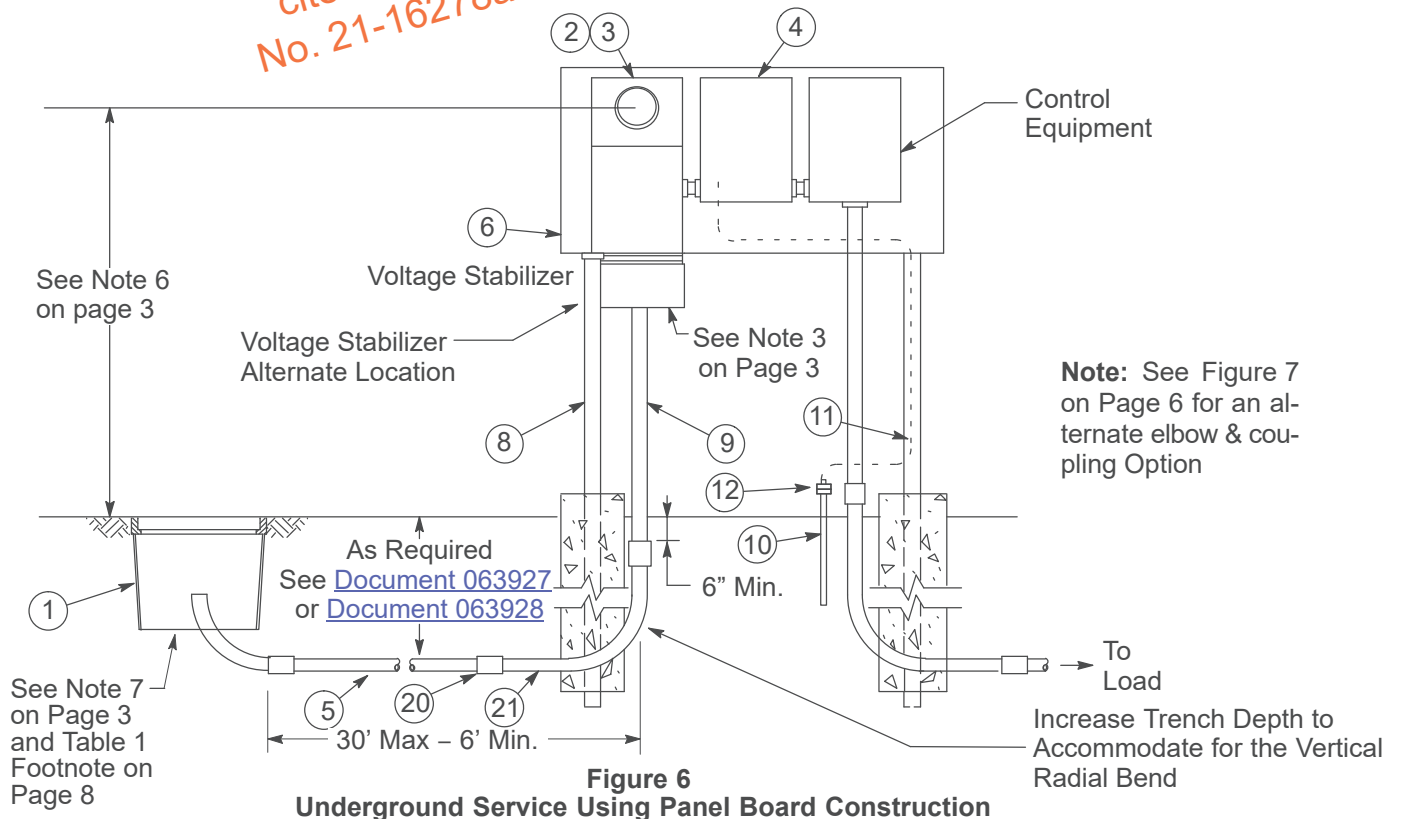
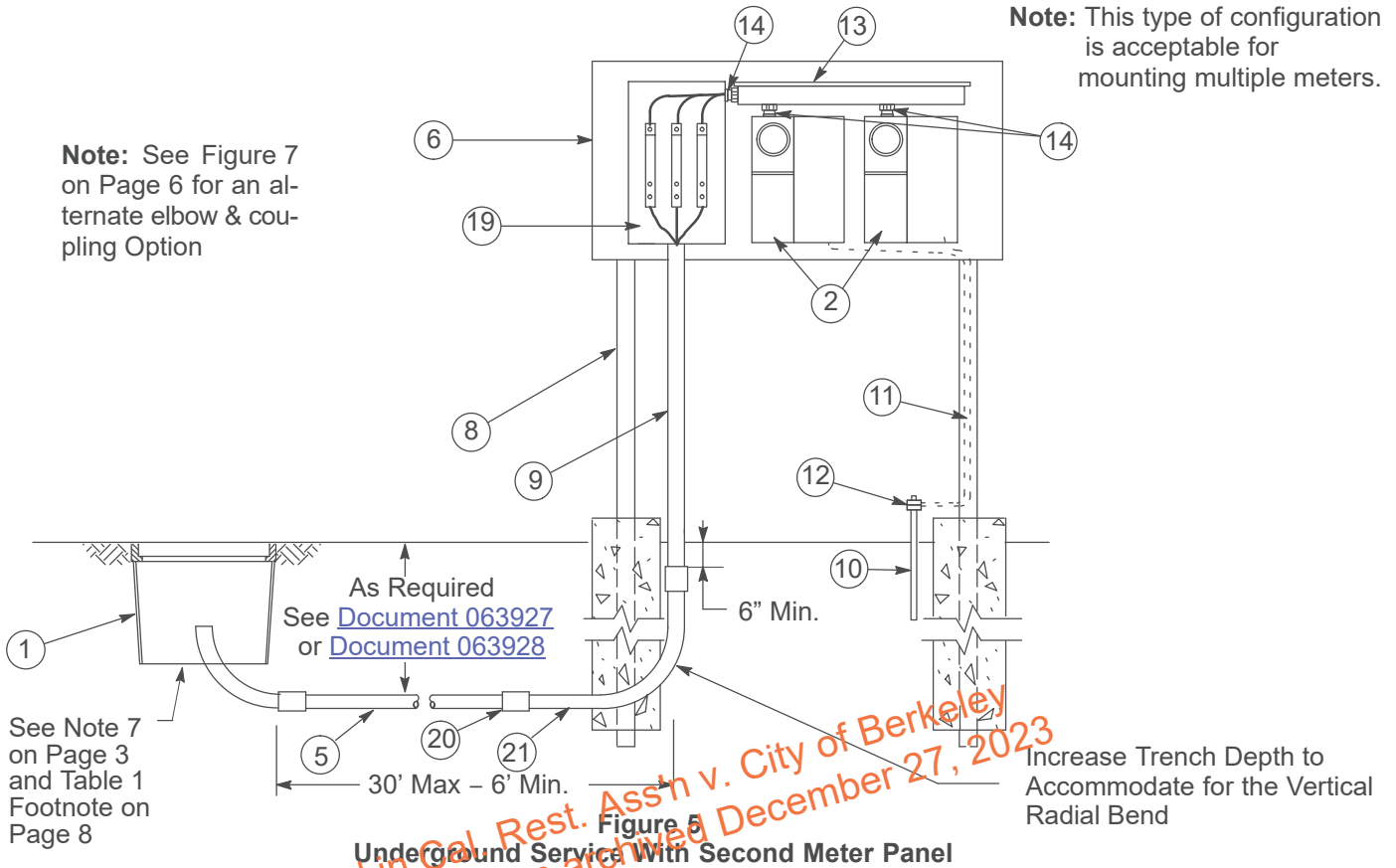


**Figure 3**  
Panel Board Construction

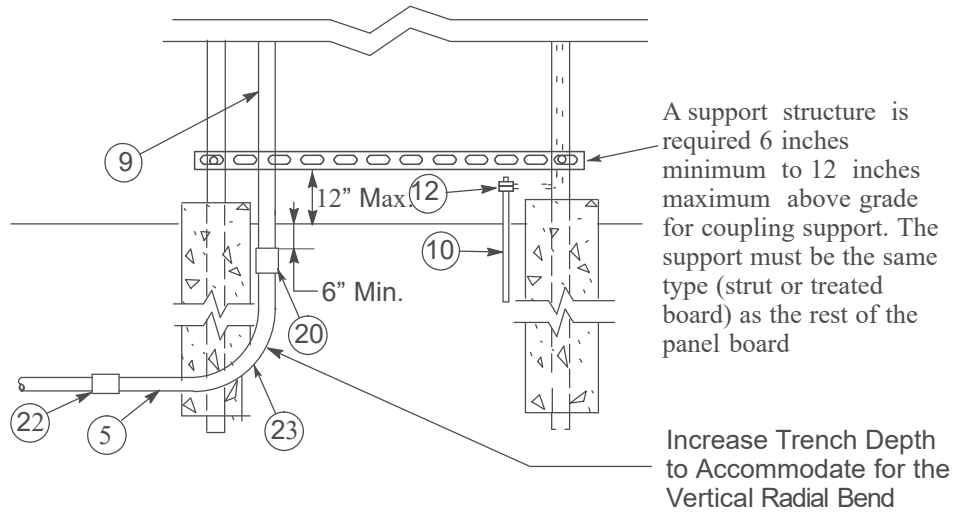
**Figure 4**  
Large Panel Board Construction

Overhead and Underground Panel Board Construction

Typical Underground Panel Board Construction



### Overhead and Underground Panel Board Construction

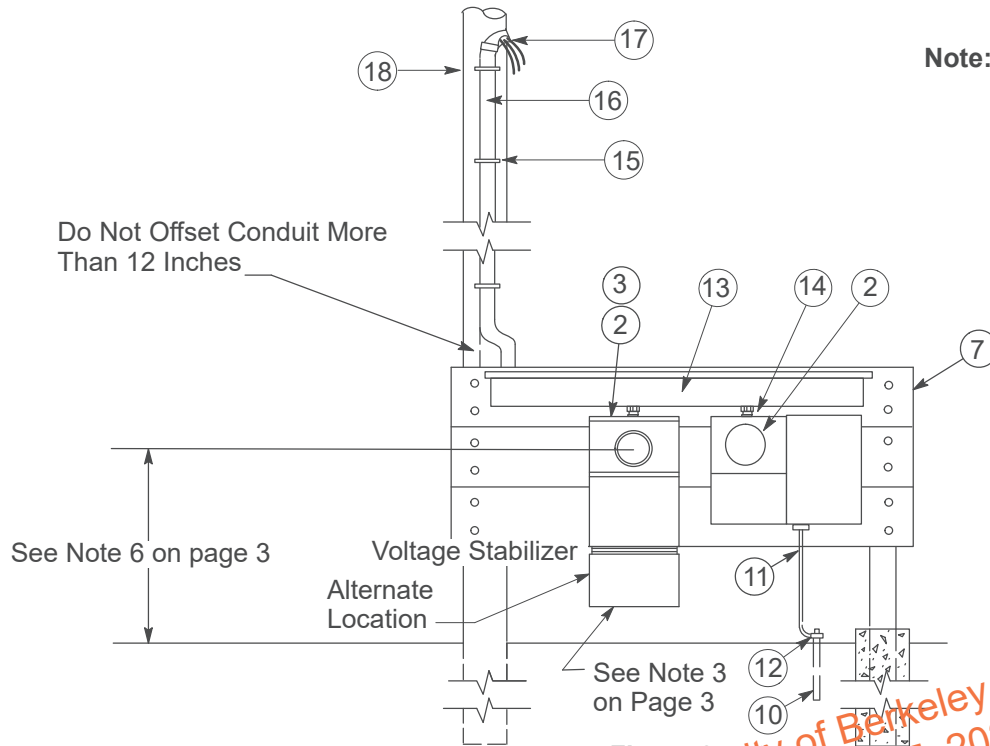


**Figure 7**  
**Alternate Option - PVC Elbow (Item 23) & Plastic-to-Steel Adapter / Coupling (Item 20)**

*cited in Cal. Rest. Ass'n v. City of Berkeley  
No. 21-16278am archived December 27, 2023*

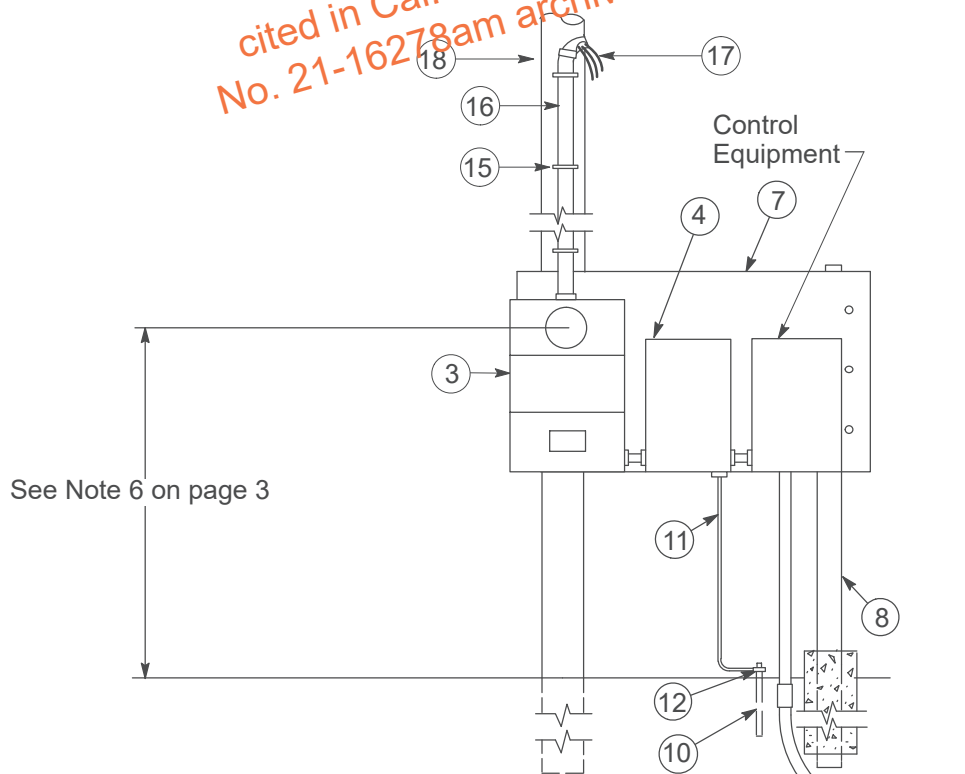
### Overhead and Underground Panel Board Construction

#### Typical Overhead Panel Board Construction



**Note:** This type of configuration is acceptable for mounting multiple meters.

**Figure 8**  
Overhead Service With Second Meter Panel



**Figure 9**  
Overhead Service Using Panel Board Construction

### Overhead and Underground Panel Board Construction



**Figure 10**  
**Typical Strut Channels Used for Panel Board Construction**

**Table 1 List of Material To Be Furnished and Installed by Customer**

Item	Description
1	Underground Pull Box, Required <sup>1</sup>
2	Self-Contained, Bused Safety Socket Box
3	Combination Meter and Current Transformer Cabinet (See Note 6 on Page 3)
4	Main Switch of Service Equipment Enclosure
5	Service Conduit, As Required
6	UG Panel Board Construction (See Figures 5 – 6)
7	OH Panel Board Construction (See Figures 7 – 8)
8	Post (See Note 1 on Page 1)
9	Conduit, Riser, Galvanized Rigid Steel, Continuous without Couplings
10	Ground Rod (See Note 2 on Page 3)
11	Ground Wire, Copper, Bare
12	Ground Clamp (As Required) for Item 10
13	Sealable Gutter
14	Metal Myers Hub With Close Nipple
15	Heavy Duty 2-Hole Pipe Strap Every 36"
16	PVC Schedule 40, minimum
17	Weatherhead
18	PG&E-Approved, Customer-Owned Pole
19	Termination Enclosure
20	Plastic-to-Steel Adapter/Coupling
21	Conduit, Bend, Galvanized Rigid Steel, Continuous without Couplings
22	Service Conduit, Coupling, As Required
23	Conduit, Bend, PVC, Continuous without Couplings

<sup>1</sup> The pull box is required to be installed but may be exempt only at the discretion of the PG&E inspector.

## Overhead and Underground Panel Board Construction

---

### Revision Notes

Revision 15 has the following changes:



1. Corrected Note 1.B.(4) on Page 2, replacing the first word "Struts" with "Unistrut".
2. Corrected Note D.(3) on Page 2, requiring thru bolts, nuts, and washers for Unistrut fasteners.
3. Corrected title of Figure 7 on Page 6, describing the coupling as a Plastic-to-Steel Adapter/Coupling.

*cited in Cal. Rest. Ass'n v. City of Berkeley  
No. 21-16278am archived December 27, 2023*



cited in Cal. Rest. Ass'n v. City of Berkeley  
No. 21-16278am archived December 27, 2023

Prepared by: MZGD

	<b>PG&amp;E-APPROVED ELECTRIC DISTRIBUTION MATERIALS MANUFACTURERS</b>		<b>066211</b>
	<b>Asset Type:</b> Electric Distribution	<b>Function:</b> Design	
<b>Issued by:</b> Michael Thibault (MLTC) 	<b>Date:</b> 03-25-22		
<b>Rev. #26:</b> This document replaces PG&E Document 066211, Rev. #25 For a description of the changes, see Page 4.			

**Purpose and Scope**

This document provides a list of PG&E-approved manufacturers of major materials for use in PG&E's Electric Distribution System.

**Table 1 PG&E-Approved Electric Distribution Materials Manufacturers**

Material	Responsible Engineer	Approved Manufacturer
Arresters	Miguel Plascencia	ABB, Siemens
Barrier Posts	M.L. Thibault	Allwire
Brackets, Overhead	Eduardo Sanchez	Aluma-Form, Chance, Joslyn, Kortick, MacLean
Cable, Primary	Liseth Villareal	Okonite, Prysmian, Southwire <sup>1</sup>
Cable, Aluminum, Secondary	Liseth Villareal	Prysmian (General Cable) <sup>1</sup> , Southwire
Cable, Copper, Secondary	Liseth Villareal	Okonite
Capacitor Controls	Miguel Plascencia	HD Electric, S&C (Energyline)
Capacitor, Overhead	Miguel Plascencia	ABB, Cooper
Capacitor, Pad-Mounted	Miguel Plascencia	Scott Engineering
Conduit, HDPE for Boring	Liseth Villareal	Dura-Line (AD Technologies)
Conduit, Smooth Core Flex	Liseth Villareal	Dura-Line (AD Technologies)
Conduit, PVC Schedule 40 and 80, UL 651, 90°C	Liseth Villareal	Prime Conduits (Carlou Bore-Gard), CertainTeed CertaCom
Conduit, PVC Schedule 40 and 80, UL 651, 90°C, Solid Core	Liseth Villareal	Atkore, Ridgeline Pipe Heritage, Prime (conduit), JM Eagle, Cantex
Conduit, PVC Schedule 40, Cellular Core	Liseth Villareal	Atkore (Rocky Mountain)
Conduit, Steel	Liseth Villareal	Allied, Western Tube
Conduit Fittings, Steel	Liseth Villareal	Picoma, Shamrock
Conductor, Overhead, AWAC Neutral Only	Genet Mengistu	Prysmian (General Cable) <sup>1</sup> , Southwire
Conductor, Overhead Covered Tree Wire	Genet Mengistu	Southwire, Taihan, Hendrix <sup>4</sup>
Connectors, Overhead, Automatic Splice <sup>3</sup>	Genet Mengistu	Blackburn, Fargo, Reliable
Connectors, Overhead, Compression Splice	Genet Mengistu	Alcoa, Blackburn, Burndy, Homac, Hubbell, Nicopress
Connectors, Overhead, Tap Clamp	Genet Mengistu	Hubbell, Maclean
Connectors, Overhead, Wedge Tap	Genet Mengistu	TE Connectivity (AMP)
Connectors, Underground, Compression, Splice	Liseth Villareal	Blackburn, Burndy, Homac, Hubbell, Kearney, Penn Union
Connectors, Underground, Pin Terminal	Liseth Villareal	Homac
Connectors, Underground, Secondary Multi-Tap Bars	Liseth Villareal	Blackburn, Homac

## PG&E-Approved Electric Distribution Materials Manufacturers

**Table 1 PG&E-Approved Electric Distribution Materials Manufacturers (continued)**

Material	Responsible Engineer	Approved Manufacturer
Connectors, Underground, Slip-Fit Transformer Secondary Bars	Liseth Villareal	Homac, Utilco
Connectors, Underground, Shearbolt	Liseth Villareal	TE-Connectivity
Connectors, Underground, Spade Terminals	Liseth Villareal	Burndy, Dossert, Homac
Connectors, Underground, Split-Bolt	Liseth Villareal	Blackburn, Burndy, Penn Union
Cutouts	Mike Lee	MacLean, Hubbell, S&C
Dead-Ends, Overhead	Eduardo Sanchez	EMC, Hubbell
Disconnect	Mike Lee	Eaton-Cooper
Elbows, 200 Amp	Liseth Villareal	Eaton-Cooper, Elastimold
Elbows, 600 Amp, Epoxy CP, and RTP	Liseth Villareal	Eaton-Cooper, Elastimold, Richards,
EPDM CP and RTP	Liseth Villareal	Elastimold, Richards
Enclosure, Frames and Covers	Calvin Yu	Madruga Iron Works, Jensen Precast, Oldcastle Precast (Utility Vault)
Enclosure, Primary – Box, Concrete	Calvin Yu	Jensen Precast, Oldcastle Precast (Utility Vault), Mid-State Concrete
Enclosure, Primary – Sectional Box, Concrete	Calvin Yu	Oldcastle Precast (Utility Vault)
Enclosure, Primary – Sectional Box, Non-Concrete	Calvin Yu	Hubbell (Strongwell/Quazite)
Enclosure, Secondary – Box, Concrete	Calvin Yu	Jensen Precast, Oldcastle Precast (Utility Vault)
Enclosure, Secondary – Box, Polymer-Concrete	Calvin Yu	Hubbell (Strongwell/Quazite), Armorcast, New Basis
Enclosure, Secondary – Pedestal	Calvin Yu	Armorcast, New Basis
Fault Indicator – Overhead	Vernal Garcia	Horstman/Power Delivery Products, SEL (Schwertzer)
Fault Indicator – Underground	Vernal Garcia	Horstman/Power Delivery Products
Fuses	Mike Lee	Chance, Combined-Tech, Eaton-Cooper, Hi-Tech, Kearny, S&C
Fuse Saver	Vernal Garcia	Siemens
Ground Rods	M.L. Thibault	Calpico, Eritech, Galvan, Nehring
Insulators, Dead-End, Silicon	Eduardo Sanchez	K-Line, MacLean, Salisbury, Advanced Rubber
Insulators, Line	Eduardo Sanchez	NGK, Porcelain Products, Victor, Hendrix, Preformed
Insulators, Standoff	Eduardo Sanchez	S&C
Interrupter – Pad-Mounted (In-Out)	Ryan Kowdley	Madruga, Elastimold
Interrupter – Pad-Mounted (Multi-Way)	Ryan Kowdley	ISG, Elastimold
Interrupter – Subsurface, 200 Amp	Ryan Kowdley	Trayer, Elastimold
Interrupter – Subsurface, 600 Amp	Ryan Kowdley	Trayer
Interrupter – Vault-Mounted	Ryan Kowdley	Elastimold, G&W
Junctions, Primary – Pad-Mounted	Ryan Kowdley	Madruga
Junctions, Primary – Subsurface	Ryan Kowdley	Elastimold (bus), Inertia (bracket)
Pad, Box, Interrupter	Ryan Kowdley	New Basis, Hubbell
Pad, Capacitor	Miguel Plascencia	Jensen Precast, Teichart Brooks, Oldcastle Precast (Utility Vault)
Pad, Flat, Interrupter	Ryan Kowdley	Hubbell
Pad, Flat, Primary Junction	Ryan Kowdley	Hubbell, Oldcastle
Pad, Flat, Switch and Fuse	Ryan Kowdley	Oldcastle Precast (Utility Vault), Jensen

**PG&E-Approved Electric Distribution Materials Manufacturers****Table 1 PG&E-Approved Electric Distribution Materials Manufacturers (continued)**

Material	Responsible Engineer	Approved Manufacturer
Pad, Transformer, Box	M.L. Thibault	Armorcast, CDR, New Basis, Strongwell/Quazite
Pad, Transformer, Concrete	M.L. Thibault	Jensen Precast, Mid-State Concrete, Structure Cast, Teichart Brooks, Oldcastle Precast (Utility Vault)
Photocontrol, Streetlight <sup>2</sup>	Maylen Yue	ALR, DTL, Fisher Pierce, Sun-Tech
Poles, Wood, Distribution (taller than 35 feet)	Richard Kauzer	McFarland Cascade, Stella-Jones
Poles, Wood, Service	Richard Kauzer	Koppers, McFarland Cascade, Nevada Wood Preserving, Thunderbolt Wood Treating, Stella-Jones
Pulling Lubricant	Lisseth Villareal	Dura-Line (Arnco), Polywater
Pulling Tape	Lisseth Villareal	Dura-Line (Arnco), Herculine, Nepco, Wellington, Milliken
Recloser	Vernal Garcia	G&W
Recloser Controller	Vernal Garcia	Beckwith
Regulator, Voltage	Miguel Plascencia	Cooper, Howard Industries
Retaining Wall	Calvin Yu	Jensen Precast, Oldcastle Precast (Utility Vault)
Sectionalizer	Mike Lee	Eaton-Cooper
Splices, UG Insulated, Primary	Lisseth Villareal	Elastimold, 3M, TE Connectivity (Raychem)
Cold-shrink Y and H Splices, UG Insulated Primary	Lisseth Villareal	Richards, TE Connectivity
Splices, UG Insulated, Secondary	Lisseth Villareal	3M
Switches, Controllers, Overhead, SCADA	Mike Lee	S&C
Switches, Controllers, Underground, SCADA	Ryan Kowdley	S&C, Trayer
Switches, Fused – Pad-Mounted	Ryan Kowdley	S&C
Switches, Fused – Subsurface	Ryan Kowdley	ABB, Trayer
Switches, Overhead, Manual	Mike Lee	Eaton-Cooper, Inertia, S&C
Switches, Pad-Mounted	Ryan Kowdley	S&C
Switches, Subsurface 200 Amp, Manual	Ryan Kowdley	Trayer, ISG, Elastimold
Switches, Subsurface 600 Amp, Manual	Ryan Kowdley	Trayer, ISG
Switches, Vault-Mounted	Ryan Kowdley	Elastimold, G&W, ISG, Trayer
Termination, Silicone Cold Shrink	Lisseth Villareal	3M, TE Connectivity (Raychem)
Transformer, Potential, Dry-Type, Outdoor Overhead	M.L. Thibault	ABB, GE
Transformer, Potential, Dry-Type, Submersible	M.L. Thibault	ABB, Artech
Transformer, Potential, Liquid-Filled, Outdoor Overhead	M.L. Thibault	ABB, Howard
Transformers, Single-Phase Overhead	M.L. Thibault	Howard Industries, Power Partners
Transformers, Single-Phase Pad-Mounted	M.L. Thibault	ABB, Howard Industries
Transformers, Single-Phase Subsurface	M.L. Thibault	ABB, Howard Industries, Power Partners
Transformers, Single-Phase Subway	M.L. Thibault	ABB, Howard Industries
Transformers, Three-Phase Network, Dry-Type	M.L. Thibault	ABB
Transformers, Three-Phase Network, Liquid Filled	M.L. Thibault	ABB, GE, Carte
Transformers, Three-Phase Overhead	M.L. Thibault	Howard Industries, Power Partners
Transformers, Three-Phase Pad-Mounted	M.L. Thibault	ABB, Cooper, Howard Industries,
Transformers, Three-Phase Subsurface	M.L. Thibault	ABB, Howard Industries

**PG&E-Approved Electric Distribution Materials Manufacturers**

---

**Table 1 PG&E-Approved Electric Distribution Materials Manufacturers (continued)**

- <sup>1</sup> Manufacturer approved for option 2 market only.
- <sup>2</sup> Fully electronic, utility grade, meeting ANSI C136.10 requirements, turn on at  $1.0 \pm 0.2$  foot candle (fc), turn off at  $1.5 \pm 0.3$  fc.
- <sup>3</sup> For AWAC neutral only.
- <sup>4</sup> Approved for 1/0-6/1 ACSR TW only.
- <sup>5</sup> Approved ONLY fo Power Interconnection Hub (PIH) Installations (refer to Table 46 in [Document 066201](#) Revision 27 or later) and 3.3MVA Transformers (Reference [Document 072146](#)).

**Notes**

1. This document may be updated between Greenbook publishing. Contact your local PG&E representative to obtain the latest version.
2. Each approved manufacturer does not necessarily supply all of the approved variations in each commodity.
3. New Basis is the parent company of Associated Plastic Products and Associated Concrete International.

**Revision Notes**

Revision 26 has the following changes:

1. Updated Table 1 Page 1 and Page 3 to current approved manufacturers.

*cited in Cal. Rest. Ass'n v. City of Berkeley  
No. 21-16278am archived December 27, 2023*



**SERVICE TO CELLULAR ON TRANSMISSION TOWER**

**068179**

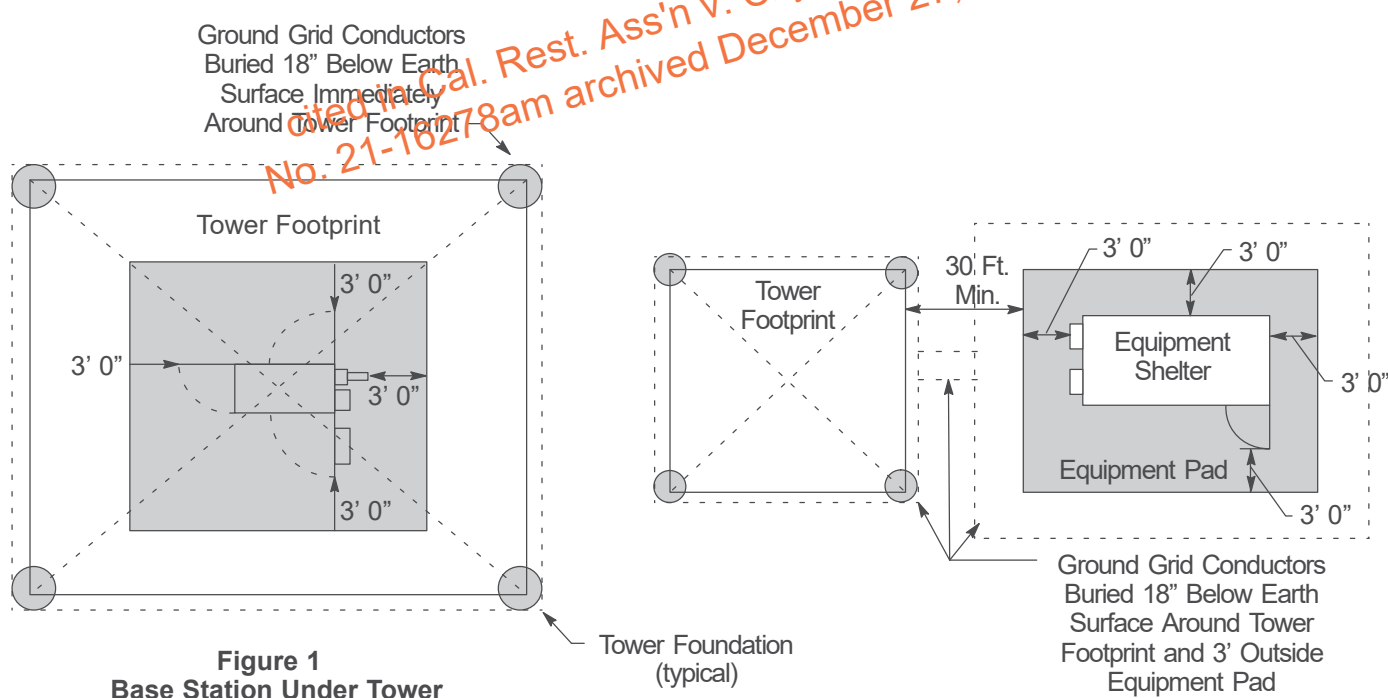
<b>Asset Type:</b> Electric Distribution	<b>Function:</b> Design
<b>Issued by:</b> D. H. Mulkey (DHM3) <i>Daniel H. Mulkey</i>	<b>Date:</b> 07-01-14
<b>Rev. #08:</b> This document replaces PG&E Document 068179, Rev. #07. For a description of the changes, see Page 2.	

**Purpose and Scope**

This document establishes safety policy, tariff interpretation, and electric service installation guidelines when providing service to wireless carriers with antennas located on high-voltage transmission towers and poles (60 kV and above).

**General Information**

- When cellular antennas are located on high-voltage transmission towers and poles, take special safety precautions when providing normal 120 V/240 V service to their base-station equipment. The base-station equipment normally is located on a pad (typically a concrete pad) directly under the tower (see Figure 1) or adjacent to the transmission-line tower (see Figure 2). There is a direct metallic path from the antenna to the base-station equipment ground bus, which also is connected to the service neutral and ground from the incoming power service. Should a fault occur on the transmission tower, fault current and voltage could transfer into the service neutral and meter. Normal construction practices for meter installations **do not** always provide adequate protection for personnel touching the meter and standing on the ground from experiencing "touch voltages" in excess of the allowable limits.



*Cal. Rest. Ass'n v. City of Berkeley  
No. 21-16278am archived December 27, 2023*

**Figure 2**  
Base Station Not Under Tower

## Guidelines

2. The applicant must determine the predicted RMS ground potential rise,  $GPR_{RMS}$ . The  $GPR_{RMS}$  may be shown at <http://wwwwt2/Weather/ATS/Grounding/Substation.asp>.
3. If the primary distribution system from which the cell site will be served is a uni-ground system (i.e., 12 kV, 17 kV, 3-wire 21 kV, or a primary neutral), and the predicted GPR is above 12,470 V symmetrical, then a dedicated transformer is required. On 3-wire primary systems, a transmission-line ground fault at the cell-site tower may create a very high ground-potential rise and become a safety concern. The PG&E transformer must be a dedicated transformer, serving only the cell site (now and forever), and the meter pedestal must be installed within the cell-site ground grid with a switch platform in front (see Note 8 below) to ensure that personnel will be standing on the equipment pad when they touch the meter. To ensure that no other customers share the 120 V/240 V neutral connection with these cell sites, these customers must have a dedicated service transformer that feeds only the cell sites.
4. If the GPR is 12,470 V symmetrical or less, **or** if the primary distribution system from which the cell site will be served is a multi-grounded system (i.e., 4-wire, 21 kV common neutral), the site is treated as a normal [Rule 16](#) service **except** the meter pedestal must be installed within the cell-site ground grid with a switch platform in front (see Note 8 below) to ensure that personnel will be standing on the equipment pad when they touch the meter. PG&E is responsible for planning, designing, and engineering its service extension using PG&E's standards for design, materials, and construction ([Rule 16](#) A.1).

## Requirements

5. [Electric Rule 2](#) special facility charges apply to any additional costs if the application requires a dedicated transformer.
6. If cell sites are on the same tower, they can share the ground grid and transformer. If the cell sites are on two adjacent towers and the towers are on the same transmission circuit, they can share the ground grid and transformer.
7. Cell sites on towers of different transmission circuits may not share the same transformer.
8. The applicant must install a 3' x 3' operating switch platform, Material Code M155036 ([Document 034851](#)), centered 6" in front of the meter pedestal and interconnect the platform with the cell-site ground grid using a 250 Cu conductor.
9. Any deviation from these guidelines requires a specific engineering analysis and design to develop sufficient compensatory design to provide touch and step protection to personnel working on the meter or cell-site equipment. Please contact applied technology services engineering personnel for assistance.
10. Installations with meters that are not within the cell-site ground grid require an isolation transformer for protection. When performing work is at such a location without an isolation transformer, correct the meter installation by either installing an isolation transformer or by extending the cell-site ground grid to encompass the meter.



## Inspections

11. Distribution employees are responsible for inspecting work on the PG&E side of the meter.

## Revision Notes

Revision 08 has the following changes:

1. Revised Note 2 above to indicate that the GPR to be used is the symmetrical value.
2. Revised Note 3 above to "uni-ground" instead of "not solidly grounded."
3. Revised Notes 6 and 7 above to refer to "transformer" rather than "service."

	<b>REQUIREMENTS FOR ALLOWING INSTALLATION OF SUBSURFACE TRANSFORMERS 072149</b>	
	<b>Asset Type:</b> Electric Distribution	<b>Function:</b> Design and Construction
<b>Issued by:</b> Michael Thibault (MLTC) 	<b>Date:</b> 12-17-20	
<b>Rev. #07:</b> This document replaces Document 072149, Rev. #06. For a description of the changes, see Page 3.		

## Purpose and Scope

This document provides special requirements for allowing the installation of a subsurface transformer. Refer to Engineering Standard [Document 076255](#), Underground Transformer Selection, for determination of the preferred transformer locations.

## General Information

### Requirements for Allowing Installation of Subsurface Transformer:

Pad-mount installations are the preferred standard for underground equipment at PG&E. Where PG&E has suitable equivalent standard subsurface transformers and the applicant pays the special facilities charges, subsurface transformers may be installed in lieu of pad-mount, however:

1. Subsurface transformers may not be installed:
  - A. Where heavy erosion occurs which may fill the enclosure with soil and cannot be integrated by retaining walls.
  - B. Where heavy snowfall occurs (generally above 3,000 foot elevation).
  - C. In areas not graded to prevent surface water from readily flowing into enclosure.
  - D. In areas where design ground water level is within 3 feet below grade.
  - E. In a drainage, a swale, or percolated area, etc.
  - F. Where local estimators or distribution planning personnel deem the location likely to flood.
2. The subsurface enclosure must be designed in accordance with the requirements of [Document 062000](#), and [Engineering Material Specification 53](#) as modified by the provisions herein.
  - A. Low Design Groundwater Level is the condition where the design groundwater level is at or below the excavation depth of the enclosure as noted in [Document 062000](#) (examples: 6' 6" below grade for the incidental 4' x 6' 6" transformer enclosure and 9' below grade for the incidental 4' 6" x 8' 6" UCD transformer enclosure).
  - B. High Design Groundwater Level is the condition where the design groundwater level is above the excavation depth of the enclosure as noted in [Document 062000](#).
3. All requests to use subsurface transformers require soil chloride testing, and determination of design ground water level to determine the suitability of soil conditions if not already disallowed for the reasons in 1.
  - A. Soil chloride testing and design groundwater level determination is the responsibility of the applicant. PG&E does not reimburse the applicant for the cost.
4. Soil chloride testing may be omitted if the applicant elects to provide exterior waterproofing of the subsurface enclosure, or where waterproofing (see Note 8 on Page 2) of the exterior surface is otherwise required such as in high design groundwater table.
  - A. Soil chloride testing must be performed under the supervision of a state licensed professional corrosion or geotechnical engineer.
  - B. Soil chloride tests shall be taken in the vicinity of the proposed subsurface transformer in a location chosen to be adequately representative of all soil strata that could impact the structure of the enclosure or the equipment



**Requirements for Allowing Installation of Subsurface Transformers**

in the enclosure, as determined and stated on the report submitted by the state licensed professional engineer in responsible charge.

C. The soil must be tested for chloride by one of the following applicable standards:

Chloride content per ASTM D4327, ASTM D512, CTM 422, or AASHTO T-291

If Chloride content is greater than 5,000 parts per million (ppm), enclosure requires waterproofing.

5. Groundwater level determination shall be performed by a state licensed professional geotechnical engineer and shall be based on site-specific borings and other information as deemed suitable by the state licensed geotechnical engineer in responsible charge.
6. Enclosures in low design groundwater level areas and where chloride content is greater than 5,000 ppm require waterproofing. If chloride content is less than 5,000 ppm, install the enclosure per [Document 062000](#).
7. Enclosures in high design groundwater level areas require waterproofing.
8. Waterproofing includes the following:
  - A. Sealing of all conduits (terminators) entering the enclosure.
  - B. Application of waterproofing membrane on all exterior surfaces including the bottom of the bottom slab. Waterproofing may be applied by the supplier or it may be applied in the field. Where extensions are added in the field, seal the joint with the required sealant prior to installation of the extension, then apply the waterproofing over the joint. Note: ground rods shall be installed before backfilling and while temporary control of groundwater is in place. Seal ground rod holes with wet-use epoxy.
  - C. Application of protection boards on all exterior surfaces including the bottom of the bottom slab to prevent membrane damage during backfill operations.
  - D. Sealing of joints between enclosure sections or extensions.
  - E. Sealing of ground rod holes.
  - F. Do not break out the four knockouts located on the bottom slab of the enclosure.

**Materials used for Waterproofing the Enclosure**

1. Waterproofing Membrane: Tremco's TREMproof 250 GC fluid applied elastomeric waterproofing Membrane, minimum 215 mils wet thickness; Carlisle's CCW Miradri 860/861 self-adhering sheet membrane, with manufacturer' recommended adhesive primer; or approved equal
2. Protection Board: Tremco's HDPE-40 protection sheet; Carlisle's CCW 200V Protection Fabric, or approved equal.
3. Rayflute Duct Sealing System (RDSS) conduit seal. Refer to [Document 062288](#).

**Requirements for Allowing Installation of Subsurface Transformers**

<b>References</b>	<b>Location</b>	<b>Document</b>
<a href="#">Single-Phase, Subsurface, Round Transformers</a> .....	<a href="#">UG-1: Transformers</a> .....	<a href="#">035313</a>
<a href="#">Underground Commercial Distribution, Three-Phase, Subsurface Transformer</a> .....	<a href="#">UG-1: Transformers</a> .....	<a href="#">039830</a>
<a href="#">Live-Front, Low-Profile, Single-Phase, Pad-Mounted Transformers</a> .....	<a href="#">UG-1: Transformers</a> .....	<a href="#">042761</a>
<a href="#">Radial, Three-Phase, Pad-Mounted Transformers</a> ...	<a href="#">UG-1: Transformers</a> .....	<a href="#">043816</a>
<a href="#">Loop-Style, Three-Phase, Pad Mounted Transformers</a>	<a href="#">UG-1: Transformers</a> .....	<a href="#">045290</a>
<a href="#">Duplex-Type, Three-Phase, Subsurface Transformer</a> .	<a href="#">UG-1: Transformers</a> .....	<a href="#">051776</a>
<a href="#">Horizontal, Single-Phase, Subsurface Transformers</a> .	<a href="#">UG-1: Transformers</a> .....	<a href="#">060578</a>
<a href="#">Primary Electric Underground Equipment Enclosures</a> .	<a href="#">UG-1: Enclosures</a> .....	<a href="#">062000</a>
<a href="#">Application of Underground Distribution Transformers</a>	<a href="#">UG-1: Transformers/Greenbook</a> .....	<a href="#">062111</a>
<a href="#">Underground Conduits</a> .....	<a href="#">UG-1: Conduits</a> .....	<a href="#">062288</a>
<a href="#">Single-Phase, Dead-Front, and Duplex, Pad-Mounted Transformer</a> .....	<a href="#">UG-1: Transformers</a> .....	<a href="#">064307</a>
<a href="#">Pad-Mount Transformers, Style IIG and IIH</a> .....	<a href="#">UG-1: Transformers</a> .....	<a href="#">072146</a>
<a href="#">Underground Transformer Selection</a> .....	<a href="#">Greenbook</a> .....	<a href="#">076255</a>
<a href="#">Design Requirements for Primary Electric Distribution Concrete Enclosures</a> .....	<a href="#">TIL</a> .....	<a href="#">EMS 53</a>

**Revision Notes**


Revision 07 has the following changes:

1. Corrected Note 2 on Page 2 to 40 mil protection sheet.

*cited in Cal. Rest. Ass'n v. City of Berkeley  
No. 21-16278am archived December 27, 2023*

cited in Cal. Rest. Ass'n v. City of Berkeley  
No. 21-16278am archived December 27, 2023

Prepared by: MZGD

	<b>VIRTUAL NET ENERGY METERING INSTALLATIONS</b>	<b>076249</b>
<b>Asset Type:</b> Electric Metering		<b>Function:</b> Construction
<b>Issued by:</b> Albert Pham (A1P5) <i>Albert Pham</i>		<b>Date:</b> 03-25-22
<b>Rev. #01:</b> This document replaces PG&E Document 076249, Rev. #00. For a description of changes, see Page 7.		

### Purpose and Scope

This document describes metering requirements and interconnecting methods on existing service equipment for renewable electrical generation facilities enrolled in the Virtual Net Energy Metering (NEMV/VNEM) program. NEMV installations requires a VNEM meter that only measures the generation produced and must not be tied into any of the individual tenant or common use meters on the premise. The totalized amount of generation registered on the VNEM meter will be shared, through the PG&E billing process, by all tenants at the site.

### General Information

1. Developers must contact PG&E's Electric Generation Interconnection (EGI) department and submit all applicable documents for approval before starting any installation.
2. Submit single line, elevation drawings and detailed pictures showing the point of interconnection. The NEMV point of interconnection will require prior review and approval from all appropriate PG&E departments before any connections can be made.
3. All installations and equipment must be approved by PG&E and approved by the local (city/county) inspection agency or the Authority Having Jurisdiction (AHJ) before any VNEM meter is set by PG&E.
4. For any NEMV installation that requires a service disconnect/reconnect, developers must coordinate with the EGI department to request for a local PG&E inspector and metering department to inspect and approve all line side connections before reconnecting service.
5. Developers must install UL approved service equipment with provisions for making generation interconnections that are not in any PG&E sealed sections and ahead of all tenant/house meters

### Specific Requirements

6. Applicants will provide, own, and install all equipment except for the PG&E VNEM meter and metering equipment (i.e. current transformers, test switch).
7. VNEM panels must have test bypass facilities and meet the requirements in Section 5 and 7 of the latest Greenbook.
8. VNEM panels greater than 200A must meet Greenbook requirements in Section 5, 9 and 10.
9. VNEM meter height, working space and gas clearances must be maintained as specified in Section 2 and 5 of the Greenbook.
10. Applicants will pull and connect generation conductors into the panel. Generation conductors in the panel must be clearly labeled "VNEM" at the point of interconnection for PG&E field personnel to identify.
11. VNEM meter panels must have the generation connected to the LOAD side and the utility grid on the LINE side of the VNEM panel. The PG&E VNEM meter will register in reverse when the generating system is producing.
12. VNEM meter panels must have proper marking and identification (i.e. apartment number, street number, use, or location). See PG&E Greenbook Section 5.5, "Meter Identification and Seals".

### Virtual Net Energy Metering Installations

#### Point of Connection

- 13. For underground service multi-meter panels, an acceptable point of connection is,
  - A Inside the main switch section, see Figure 1, with approval from the local AHJ, or
  - B Install a sealable PG&E approved termination enclosure, see Figure 2. Refer to [Document 058817](#), Terminating Underground Electric Services 0–600 Volts in Customer-Owned Facilities, for termination enclosure specifications and requirements.
- 14. For overhead service multi-meter panels, an acceptable point of connection is,
  - A Inside the main switch section, see Figure 3, with approval from the local AHJ, or
  - B Install a sealable wiring gutter with approval from the local AHJ. See Figure 4.

#### Multi-Meter Switchboards

- 15. Single metered switchboards with the PG&E service termination below the metering current transformer (CT) section cannot be used for any NEMV interconnections. See Figure 5.
- 16. The PG&E service termination must be in a separate enclosure/section adjacent to the metering CT section. In addition, the PG&E service termination section must have clear separation, as determined by PG&E, between the PG&E service conductors and conductors to the CT section. See Figure 6, and Figure 7.
- 17. Because of various types of configurations and arrangements of switchboard compartments, the items below must be satisfied in order to interconnect into an existing switchboard. All other switchboard configurations will be denied interconnection.
  - A The service termination section is bus duct.
  - B An overhead service where PG&E’s service conductors end at the weather head. See Figure 8.
  - C The service termination section for an underground service has clear separation, as determined by PG&E, between the PG&E service conductors and conductors to the CT section. See Figure 9.

#### Generator AC disconnect Requirements

- 18. Allows visible verification that an air-gap of separation has occurred between the blades and contact point.
- 19. Must be fused for generators that do not have overcurrent protection at the point of interconnection with the utility.
- 20. Must be installed within 10 feet and line of sight to the VNEM meter.
- 21. Must meet all other requirements as described in [Document 060559](#), Disconnect Switch Requirements For Distributed Generation Customers.

#### Final Inspection Requirements

- 22. All equipment has been approved by PG&E and the local (city/county) inspection agency or the authority having jurisdiction.
- 23. VNEM point of connection has been reviewed and approved by all appropriate PG&E departments.
- 24. AC disconnect has proper labeling and VNEM meter panels have proper marking and identification.

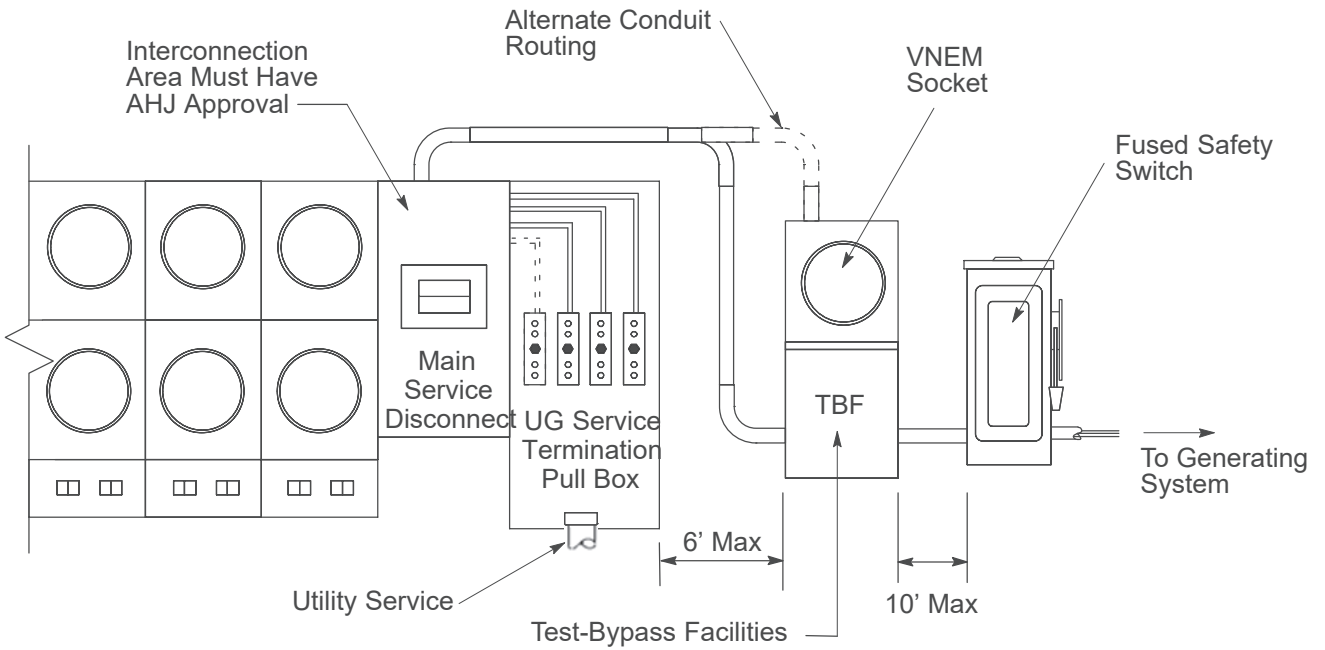
#### References

References	Location	Document
<a href="#">Terminating Underground Electric Services 0–600 Volts in Customer-Owned Facilities</a>	<a href="#">UG-1 Services/Greenbook</a>	<a href="#">058817</a>
<a href="#">Disconnect Switch for Distributed Generation Customers</a>	<a href="#">Greenbook</a>	<a href="#">060559</a>

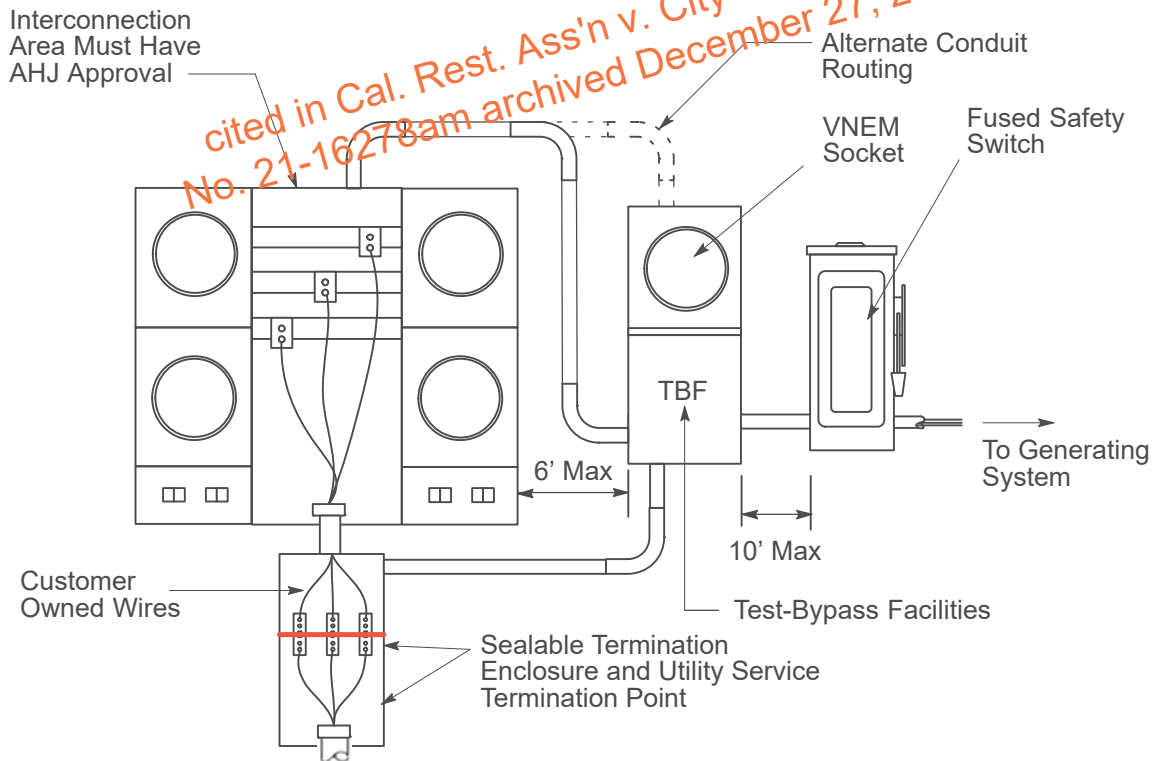
cited in Cal Best Ass'n v. City of Berkeley  
 No. 21-16278am archived December 27, 2023

### Virtual Net Energy Metering Installations

#### Point on Connection: Underground Service Wall-Mounted Equipment



**Figure 1**  
Interconnection in Main Disconnect Section

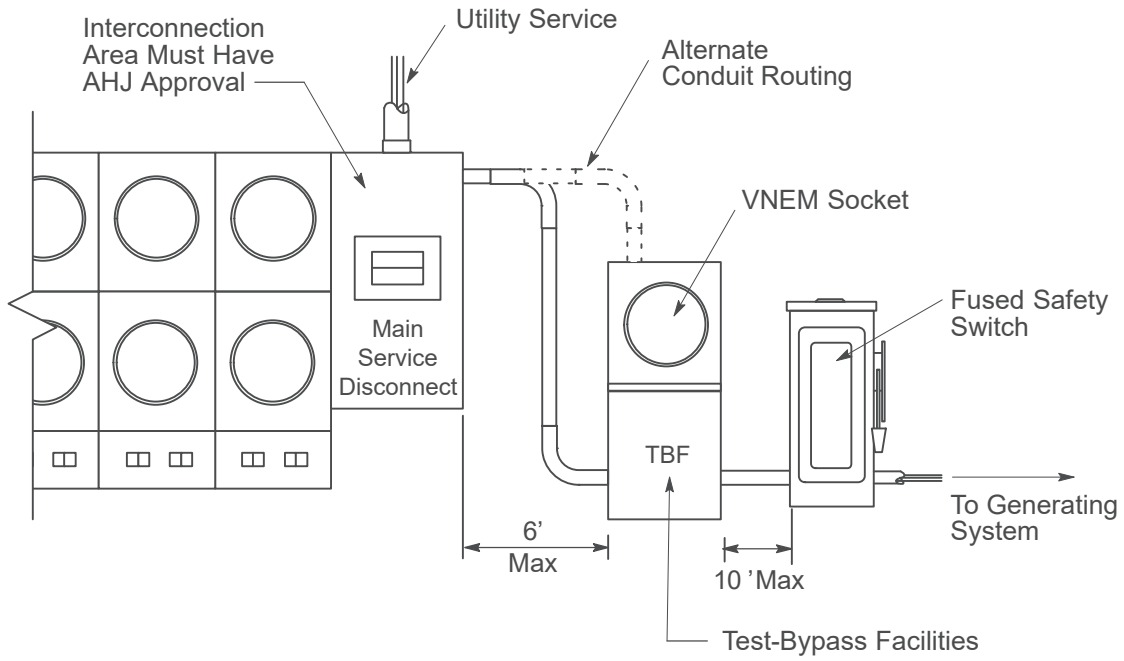


**Figure 2**  
Interconnection with New Service Termination Enclosure

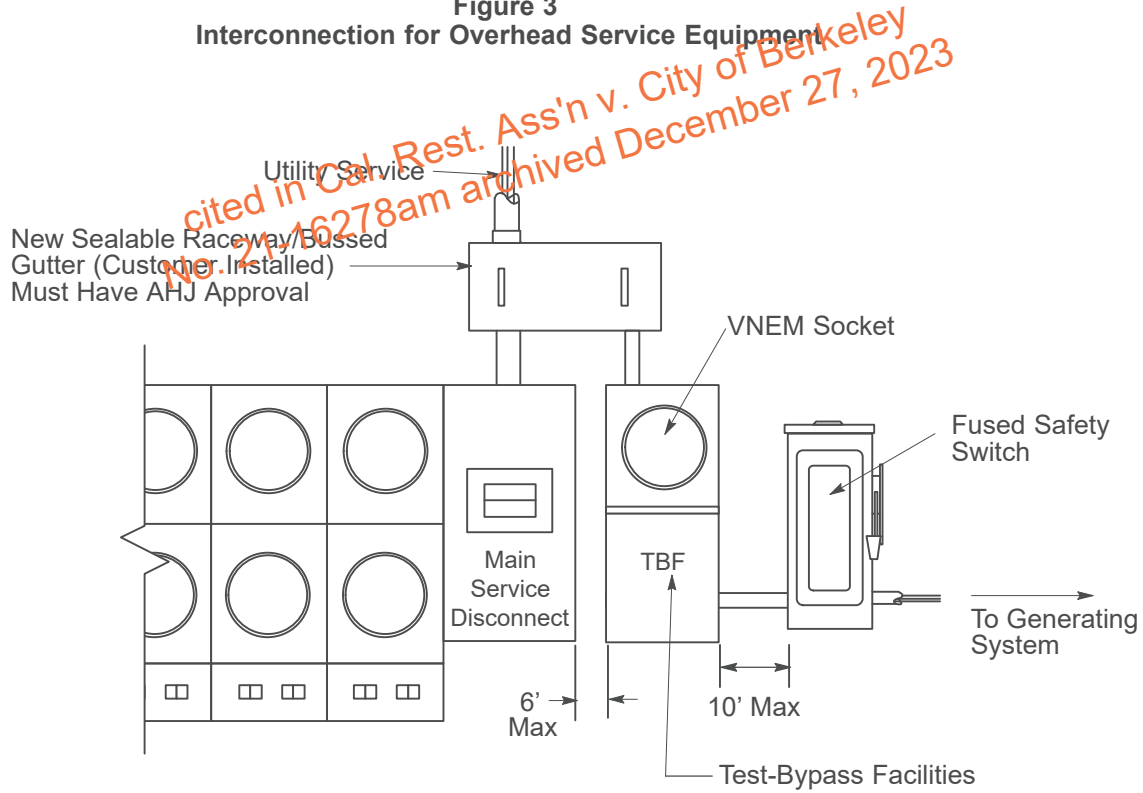
*cited in Cal. Rest. Ass'n v. City of Berkeley  
No. 21-16278am archived December 27, 2023*

### Virtual Net Energy Metering Installations

#### Point on Connection: Overhead Service Wall-Mounted Equipment



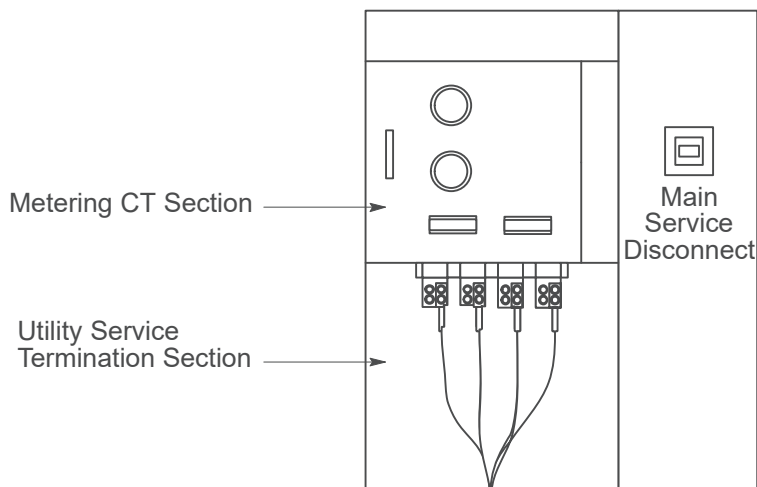
**Figure 3**  
Interconnection for Overhead Service Equipment



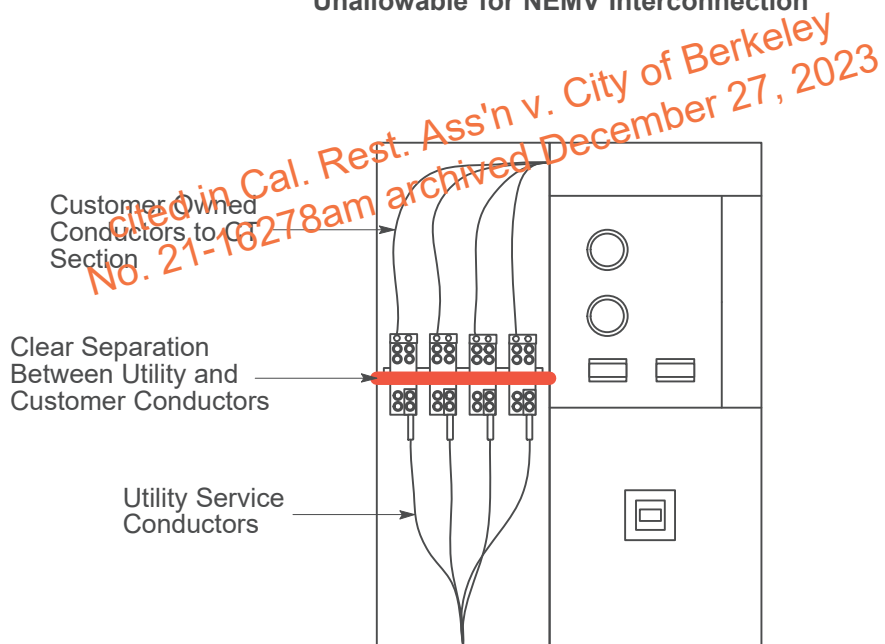
**Figure 4**  
Interconnection with New Sealable Raceway/Bussed Gutter

### Virtual Net Energy Metering Installations

#### Point on Connection: Floor Standing Switchboards



**Figure 5**  
**Unallowable for NEMV Interconnection**



**Figure 6**  
**Pull Section and Clear Separation**



### Virtual Net Energy Metering Installations

#### Point on Connection:

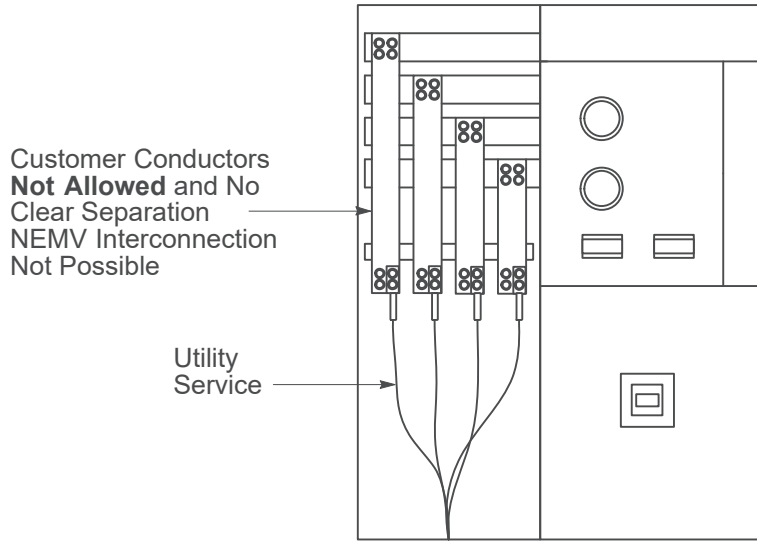


Figure 7  
Pull Section with No Clear Separation

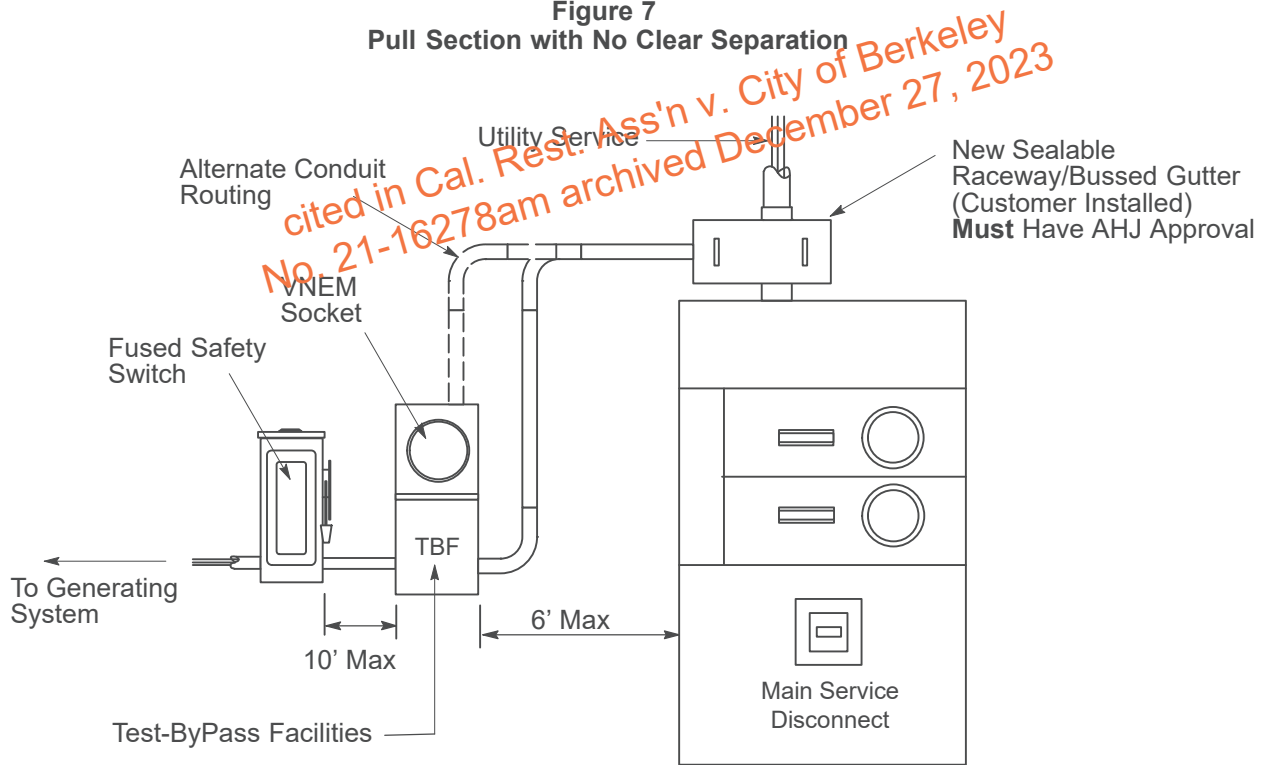
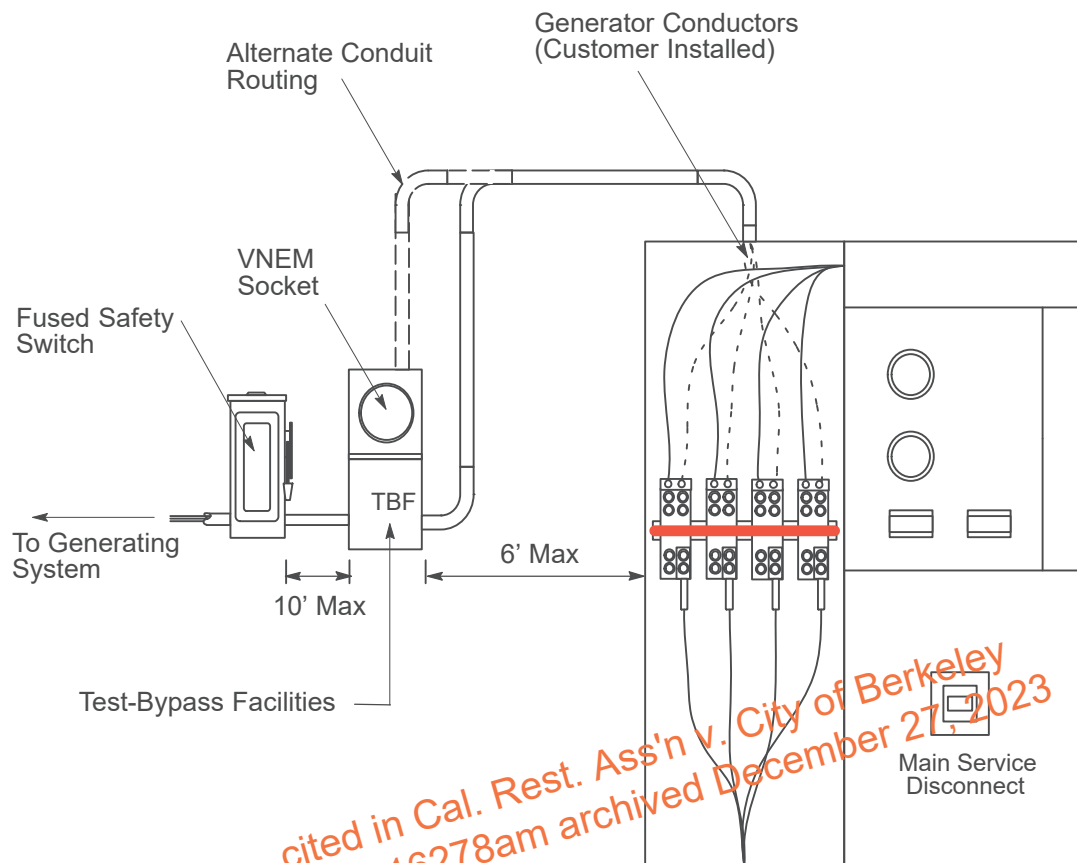


Figure 8  
Interconnection on Overhead Switchboard

## Virtual Net Energy Metering Installations

### Point on Connection: Floor-Standing Switchboards





**Figure 9**  
Interconnection on Underground Service Switches

#### Revision Notes

Revision 01 has the following changes:

1. Revised interconnection location on Figure 2.
2. Removed alternate interconnection location on Figure 9.

cited in Cal. Rest. Ass'n v. City of Berkeley  
No. 21-16278am archived December 27, 2023

	<b>PAINTING OF PG&amp;E ELECTRIC DISTRIBUTION PAD-MOUNTED AND SUBSURFACE EQUIPMENT</b>	<b>076268</b>
	<b>Asset Type:</b> Electric Distribution	<b>Function:</b> Design and Construction
<b>Issued by:</b> M. L. Thibault (MLTC) 	<b>Date:</b> 08-15-17	
<b>Rev. #00:</b> This is a new document.		

**Purpose and Scope**

This document specifies the requirements necessary and background information available for supporting denial of requests from those other than PG&E concerning modification of exterior coatings for Distribution Pad-Mounted Equipment.

**General Information**

This document is also included in the following manuals:

- *Electric and Gas Service Requirements Manual* ("[Greenbook](#)")

**References**

References	Location	Document
<a href="#">Marking, Numbering, and Identification of Line Structures</a> .....	<a href="#">OH: Marking</a> .....	<a href="#">022168</a>
<a href="#">Pad-Mounted, Load-Break Switches and Fuses</a> .....	<a href="#">UG-1: Switches</a> .....	<a href="#">053318</a>
<a href="#">Installation of Three-Phase, Pad-Mounted Transformer, Ground Level or Dry Vault</a> .....	<a href="#">UG-1: Transformers/Greenbook</a> .....	<a href="#">057521</a>
<a href="#">Landscape Screen for Pad-Mounted Transformers</a> .....	<a href="#">Greenbook</a> .....	<a href="#">063422</a>
<a href="#">Box-Pad for Pad-Mounted Transformers</a> .....	<a href="#">UG-1: Transformers/Greenbook</a> .....	<a href="#">064309</a>
<a href="#">Pad-Mount Capacitor</a> .....	<a href="#">UG-1: General</a> .....	<a href="#">066197</a>
<a href="#">Installation of Pad-Mounted, Load-Break Junction</a> .....	<a href="#">UG-1: Switches</a> .....	<a href="#">066212</a>
<a href="#">Engineering Material Specification 86, "Single-Phase, and Three-Phase Pad-Mounted Distribution Transformers"</a> .....	<a href="#">TIL</a> .....	<a href="#">EMS 86</a>
<a href="#">Engineering Material Specification 91, "Single-Phase and Three-Phase Subsurface Distribution Transformers</a> .....	<a href="#">TIL</a> .....	<a href="#">EMS91</a>
<a href="#">General Order (G.O.) 128</a> .....	<a href="#">TIL</a> .....	<a href="#">G.O. 128</a>

**Background**

1. Pacific Gas and Electric Utility (PG&E) receives requests from many Groups such as Service Organizations, Cities, and Counties requesting approvals for painting or placing murals on PG&E distribution line assets (Pad-mount Transformer, Switches, Capacitors, etc.) for many well-meaning reasons and causes. PG&E distribution assets are prohibited from being painted by any other than those in the employ or contracted by PG&E.
2. Existing Assets which may have previously been painted by those other than PG&E prior to the issuance of this document will not be allowed to "freshen up" or repaint existing assets post issuance of this document.
3. California Public Utilities Commission (CPUC) [General Order \(G.O.\) 128](#), Rule 17.8 requires that subsurface and pad-mounted equipment be clearly marked as to ownership. To comply with this rule, PG&E requires standardized signage on these devices which identifies them as PG&E utility assets. these requirements are contained within the corresponding Engineering Material Specifications (EMS).

### Painting of PG&E Electric Distribution Pad-Mounted and Subsurface Equipment

- A Signage identifies these devices by their operating number making it quick and easy for PG&E Employees to locate and identify these devices in the event of emergencies or for the purposes of required maintenance and inspection.
  - B Uniformity and consistency of the exterior color and pattern assist in locating and identifying these devices. Non-Uniformity of color as well covering of signage on these devices could prolong restoration efforts and desensitize the general public from the dangers of tampering and/or not maintaining clearances from these Assets.
4. California and Federal Law have cases which guide how PG&E would have to perform were this altering of Assets allowed. Current procedures and processes disallow PG&E from implementing these requirements when overlaid on Operational Procedures.
  5. Allowing cities and their citizens to paint on public utility assets creates two possibly significant legal issues concerning ownership of the painting and a third party’s right to express their views on our equipment.
    - A California law protects “fine art” including murals painted on someone else’s (i.e., Utility’s) property. (Cal. Civ. Code § 987(a).) The code provides that once a mural is painted on the surface (transformer housing, for example), only the artist or his or her heirs (until 50 years after the artist’s death), may authorize “any physical defacement, mutilation, alteration, or destruction of a work of fine art.” (Cal. Civ. Code § 987(c)(1).)
    - B In *Pacific Gas and Electric. Co. v. Public Util. Comm.* (1985) 475 U.S. 1 the United States Supreme Court ruled that PG&E had a right to control access to its property for expressive purposes so long as we did not open that property as a forum for public expression. The court contrasted PG&E’s right with other property owners who had allowed their private property to be used for some types of public expression; the court held that that property had become a public forum and the owners could not thereafter exclude other speakers and other messages from their property.

#### Examples of Painted Assets



Figure 1  
Examples of Enclosures in Violation of Note 2 (above)

#### Revision Notes

Revision 00 has the following changes:

1. This is a new document.

	<b>WHOLESALE DISTRIBUTION TARIFF (WDT) INTERCONNECTION DESIGN OPTIONS FOR PRIMARY VOLTAGE SERVICE</b>		<b>092816</b>
	<b>Asset Type:</b> Electric T&D	<b>Function:</b> Design	
<b>Issued by:</b> Michael Thibault (MLTC) 	<b>Date:</b> 12-17-20		
<b>Rev. #00:</b> This is a new document.			

### Purpose and Scope

This document describes the options available and requirements of Wholesale Distribution Customers (Other Utilities or Customers which can connect to PG&E's Primary Voltage Distribution System and receive energy at Wholesale Rates as defined in the Wholesale Distribution Tariff – WDT). These Distribution Customers must have an executed Wholesale Distribution Tariff and Service Agreement (SA) filed with FERC (Federal Energy Regulatory Commission) to be eligible for these options of Interconnection. Excluded from this Document and disallowed are new WDT Connections at Secondary Voltage Levels (Below 600 Vac) as well as connections to Network Primary Voltage Circuits and Network Secondary Voltage Systems.

This document details the equipment and connections requirements to safely interconnect to PG&E's Electric Distribution System. These connections require clearly separated asset ownership while allowing for both parties (PG&E and the Wholesale Customer) to complete maintenance and operation tasks with little or minimal interaction requirements between the parties. Variations of these examples should be submitted through the Variance Process (TD-2951P-01 Request for Variance from Electric Distribution Standards) and discussed in advance with Electric Distribution Planning Departments prior to approval allowing Project progression. The intent of this document is that these generalized examples are the ONLY allowable configurations to be approved without an approved variance in the Electronic Document Routing System (EDRS). Variances are NOT precedent setting but rather are on a Project by Project Case.

Distribution Customers must provide space and locations for the equipment identified in Table 1. The intent of the equipment requirements identified in Table 1 allow the Distribution Customer (WDT Eligible Electric Utility Customer) to function largely independent of the Distribution Provider (PG&E) while at the same time isolating failures to the Distribution Customers System from affecting the PG&E Distribution System.

**Table 1 Intervening Facility Requirements (WDT Customer Owned)**

Intervening Facility	Overhead	Underground
Disconnect Switch	Required	Required
Protective Device	Required	Required
Wood Pole	Required	Not Required
Conductor <sup>1</sup>	Required	Required

<sup>1</sup> The WDT Customer must own the conductor from either the Metering Panel or Protective Device depending on the Point of Interconnection (POI) which is discussed in the Application Section of this document

Excluded from this Document are cases in which Generation is connected to the PG&E Distribution Grid. Retail Interconnection Projects are detailed in the [Distribution Interconnection Handbook](#). Additionally, excluded from this document is the [Document TD-2999B-030](#) Technical Requirements for Electric Service Interconnection at Primary Distribution Voltages. [Document TD-2999B-030](#) applies to Retail Interconnections in contrast to this document which pertains to Wholesale Interconnections. In general, most documents included in the PG&E Underground and Overhead Construction Manual have been developed specifically for Retail applications unless specifically identified as pertaining to both Retail and Wholesale Customers.

**Wholesale Distribution Tariff (WDT)  
Interconnection Design Options for Primary Voltage Service**

**General Information**

**Utilities having a WDT Tariff on File with FERC:**

- WD Tariff, SA 3 : Port of Oakland WDT Service Agreement
- WD Tariff, SA 15 : Westside Power Authority IA and WDT Service Agreement
- WD Tariff, SA 17 : Western Area Power Administration WDT Service Agreement
- WD Tariff, SA 30 : Power and Water Resources Pooling Authority IA and WDT SAs
- WD Tariff, SA 56 : Power and Water Resources Pooling Authority IA and WDT SAs
- WD Tariff, SA 275 : City and County of San Francisco IA and WDT SA
- WD Tariff, SA 382 : Shelter Cove Resort Improvement District IA and WDT SA

**This document will be included in the following manuals:**

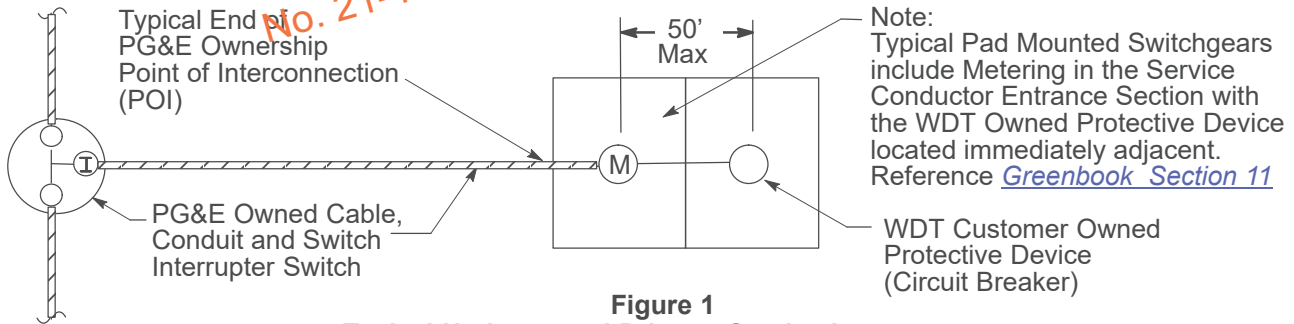
- [Electric and Gas Service Requirements Manual \("Greenbook"\)](#)
- [Electric Underground Construction Manual – Services Section](#)
- [Electric Overhead Construction Manual – Services Section](#)

**Application**

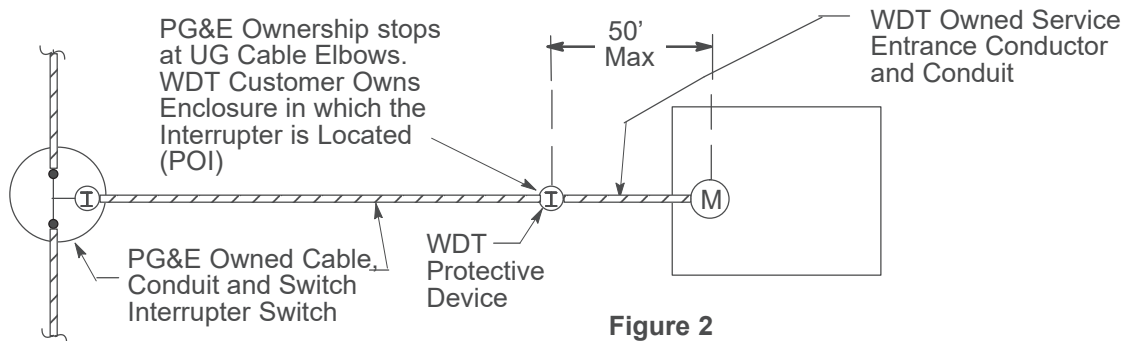
Below is a list of representative requirements for Wholesale Interconnection. These requirement details indicate associated PG&E Installation and Design Documentation which satisfy the Intervening Facilities identified in Table 1 Intervening Facility Requirements (WDT Customer Owned) on Page 1. These installations allow the WDT Customer to operate and perform maintenance on their System exclusive of PG&E involvement through operation of WDT Customer owned Protective Devices. These designs provide the necessary equipment to interconnect seamlessly into the existing PG&E Distribution System.

**Primary Underground Service Connection**

This is a typical installation in urban areas such as San Jose, Oakland and San Francisco but may be present throughout the PG&E System.



**Figure 1  
Typical Underground Primary Service Interconnect**



**Figure 2  
Alternate Primary UG Service Interconnect**

## Wholesale Distribution Tariff (WDT) Interconnection Design Options for Primary Voltage Service

### Primary Underground Service Connection (continued)

At the point designated by PG&E as the connection to the existing PG&E Electric Distribution System, PG&E will install and own a Gang Operated Protective Device such as a Switch Interrupter Switch. This device may be Pad-Mounted or a Subsurface device depending on local space constraints and/or requirements. Installation of this PG&E owned protective device allows selective clearing of the Tap Line from the PG&E System should faults not be cleared by the WDT Customer Owned Primary Protective Device. Reference [Document 068188 \(Installation of Automatic Pad-Mounted Interrupters for Underground Distribution Lines\)](#) for the 200 A Pad Mounted Interrupter to be owned by the WDT Customer. Reference [Document 066208 \(Installation of Automatic Subsurface Interrupters for Primary Equipment Enclosures\)](#) for the Subsurface Interrupter Installations.

Primary Metering by the WDT Customer is preferred to be immediately on the Source side of the WDT Customer Owned Protective Device as indicated in Figure 1 on Page 2 . In such a configuration, PG&E's Ownership of the Underground Conductor and Conduit stop at the Cable Terminals on the Meter Panel which is immediately adjacent the WDT Customer Owned Service Main Breaker. In some cases, this will prove difficult for the WDT Customer to accomplish and they may instead request the Alternative identified in Figure 2 on Page 2. Where the WDT Owned Protective Device is requested to be located on the Source Side of the Metering and PG&E can accommodate this request, PG&E's Ownership of conduit will stop at the entrance to the subsurface enclosure and cable will stop at the Cable Elbows landing on the WDT Customer owned Interrupter. PG&E or the WDT Customer may own the Revenue Meter. Non-PG&E owned meters are covered by [Electric Rule 22 Direct Access](#). PG&E SHALL install, own and maintain the associate Metering Potential Transformers (PTs) and Current Transformers (CTs) located in the Metering Panel that will be owned by the WDT Customer. The WDT Customer's Metering must be within 50 cable feet of the WDT Customer owned Protective Device to avoid uncompensated line loss through the cable. Further than 50' should be compensated for in the metering programming.

Should the WDT Customer request the Alternative in Figure 2 on Page 2 they SHALL only use the PG&E Material Coded Devices to be installed per the above-mentioned PG&E Standards. This installation requirement is necessary to allow PG&E Personnel to safely operate the cabling on the WDT Customer Owned Protective Device. PG&E Personnel SHALL NOT operate the WDT Customer Owned Protective Device (Open, Close, Setting Changes).

### Primary Overhead Service Connection

This is a typical installation in Rural Areas such as the Inland and San Joaquin Valley Service Territory Areas.

At the point designated by PG&E as the connection to the existing PG&E System, PG&E will install, own and operate a Gang Operated Protective Device such as a Recloser. Installation of this protective device allows selective clearing of the Tap Line and associated load for the WDT Customer should faults not be cleared by the WDT Customer Owned Primary Protective Device. The WDT Load will then feed through the Pole Mounted Primary Metering identified in [Document 058779 Pole-Top Primary Metering Installation, \(12 or 21kV Line\)](#).

Primary Metering for WDT Services should occur before the WDT Customer Owned Protective Device. In this case PG&E's Ownership of the Overhead Conductor stops at the PT's and CTs identified in [Document 058779 Pole-Top Primary Metering Installation, \(12 or 21kV Line\)](#). Where the WDT Customer Owned Protective Device is requested by the WDT Customer to be located on the Source Side of the Metering and PG&E can accommodate this request, PG&E's Ownership stops at the Source Side Disconnects on the WDT Customer Owned Protective Device.

Note – Unlike the PG&E Standard Design for Line Reclosers which is identified in [Document 066199 Installing Automatic Circuit Reclosers on Distribution Lines](#), there SHALL NOT be a U.S. switch (identified in [Document 066195 25 kV Underarm Side-Break Switch](#)) installed as a Bypass to the WDT Customer owned Line Recloser whether on the Source or Load Side of the Primary Metering in the Wholesale Application. This variance to the PG&E Standard Design disallows the WDT Customer to bypass their Protection Device thereby moving the primary sectionalizing device responsibility to PG&E's Protective Device.

PG&E or the WDT Customer may own the Revenue Meter. PG&E SHALL install, own and maintain the associate Metering Potential Transformers (PTs) and Current Transformers (CTs) located on the Metering Pole that will be owned by the WDT Customer. The WDT Customers Metering must be within 50 feet of the WDT Customer owned Protective Device to avoid uncompensated line losses. Further than 50' should be compensated for in the metering programming.

The WDT Customer SHALL use the PG&E Material Coded Device identified in the PG&E Standards. This installation requirement is necessary to allow PG&E Personnel to safely connect the PG&E Overhead Conductors to the WDT Owned Line Recloser. PG&E Personnel SHALL NOT operate the WDT Customer owned Protective Device (Open, Close, Setting Changes).



UG-1: Services  
OH: Services  
Greenbook

**Wholesale Distribution Tariff (WDT)  
Interconnection Design Options for Primary Voltage Service**

References	Location	Document
<a href="#">600-Amp Separable Insulated Connectors</a> .....	<a href="#">UG-1:Terminations</a> .....	<a href="#">051071</a>
<a href="#">Pole-Mounted Primary Metering Installation (12 or 21 KV Line)</a> .....	<a href="#">OH: Meters/EMWP</a> .....	<a href="#">058779</a>
<a href="#">Cables for Underground Distribution</a> .....	<a href="#">UG-1:Cable</a> .....	<a href="#">039955</a>
<a href="#">25 kV Underarm Side-Break Switch</a> .....	<a href="#">OH: Switches</a> .....	<a href="#">066195</a>
<a href="#">Installation of Automatic Circuit Reclosures on Distribution Lines:</a> .....	<a href="#">OH: Switches</a> .....	<a href="#">066199</a>
<a href="#">Installation of Automatic Subsurface Interrupters for Primary Equipment Enclosures</a> .....	<a href="#">UG-1: Switches</a> .....	<a href="#">066208</a>
<a href="#">Request for Variance from Electric Distribution Standards</a> .....	<a href="#">TIL</a> .....	<a href="#">TD-2951P-01</a>
<a href="#">Technical Requirements for Electric Service Interconnection at Primary Distribution</a> .....	<a href="#">TIL</a> .....	<a href="#">TD-2999B-030</a>
<a href="#">Distribution Interconnection Handbook</a>		
<a href="#">Electric and Gas Service Requirements Manual ("Greenbook")</a>		
<a href="#">Electric Overhead Construction Manual – Services Section</a>		
<a href="#">Electric Underground Construction Manual – Services Section</a>		


**Revision Notes**

Revision 00 has the following changes:

1. This is a new document.

*cited in Cal. Rest. Ass'n v. City of Berkeley  
No. 21-16278am archived December 27, 2023*

Prepared by: ABB1

	<b>SUPPLY SIDE INTERCONNECTION REQUIREMENTS FOR DISTRIBUTED GENERATION</b>	<b>094670</b>
	<b>Asset Type:</b> Electric Metering	<b>Function:</b> Construction
<b>Issued by:</b> Albert Pham (A1P5) <i>albert Pham</i>	<b>Date:</b> 9-15-20	
<b>Rev. #00:</b> This is a new document. This document replaces PG&E Bulletin TD-6999B-048, "Requirements for Line Side Interconnections for Distributed Generation". For a description of changes, see See Page 7.		

**Purpose and Scope**

This document describes interconnection requirements for Net Energy Metering (NEM) projects where a supply side interconnection is requested by Distributed Generation (DG) customers on 0 – 600 Volt meter panels and switchboards. A supply side interconnection is defined as a connection between the PG&E electric meter and the main service disconnect / breaker. For Virtual Net Energy Metering (VNEM) projects where the proposed interconnection is on the line side of the PG&E meter, refer to [Document 076249](#).

**References**

	<b>Location</b>	<b>Document</b>
<a href="#">Virtual Net Energy Metering Installation</a> . . . . .	<a href="#">OH: Meters/UG-1 Services/Greenbook</a>	. <a href="#">076249</a>
<a href="#">Disconnect Switch Requirements for Distributed Generation Customers</a> . . . . .	<a href="#">Greenbook</a> . . . . .	. <a href="#">060559</a>

*Rest. Ass'n v. City of Berkeley  
No. 21-16278am received December 27, 2023*

**General Information**

PG&E's preferred distributed generation interconnection is on the load side of the panel, after the service main disconnect. This interconnection is described in National Electrical Code (NEC) 705.

For supply side interconnections, the following requirements apply:

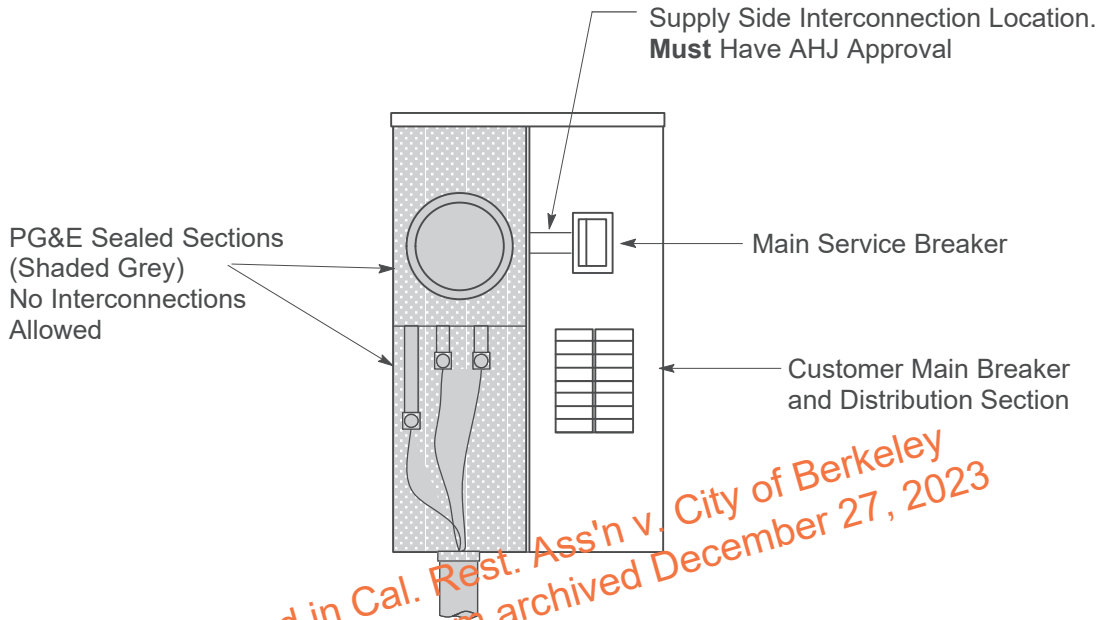
1. The interconnection must be between the PG&E Meter and main breaker in the customer's section of the equipment and not in the PG&E termination, metering, or other sealed compartment or section.
2. PG&E recommends the interconnection proposal and single line diagrams are pre-approved by their Authority Having Jurisdiction (AHJ).
3. The AHJ must sign off the building permit for the generation system before PG&E will give the final approval to operate.
4. Residential "solar ready" service panels designed with a dedicated alternative energy (customer generation) circuit breaker on the supply side of the main breaker is allowable. "Solar ready" panels must be PG&E and EUSERC approved and have factory installed labels showing location and ratings of the generation source.
5. New pad-mounted (floor-standing) switchboards must have a separate compartment / section dedicated for supply side connections. Or, the switchboard manufacturer may design and install provisions for a supply side connection prior to the switchboard being installed and energized.

**Specific Requirements**

1. When requesting to propose a supply side interconnection, submit the following to the PG&E Electric Generation Interconnection (EGI) department:
  - A. Single line diagram clearly showing the supply side interconnection.
  - B. Photos of the service panel.
    1. Photos must show the whole service panel and all switchboard sections, no close-up photos.
    2. Photos must be marked-up to show where the interconnection will be and how conductors will be routed to the Interconnection Location.

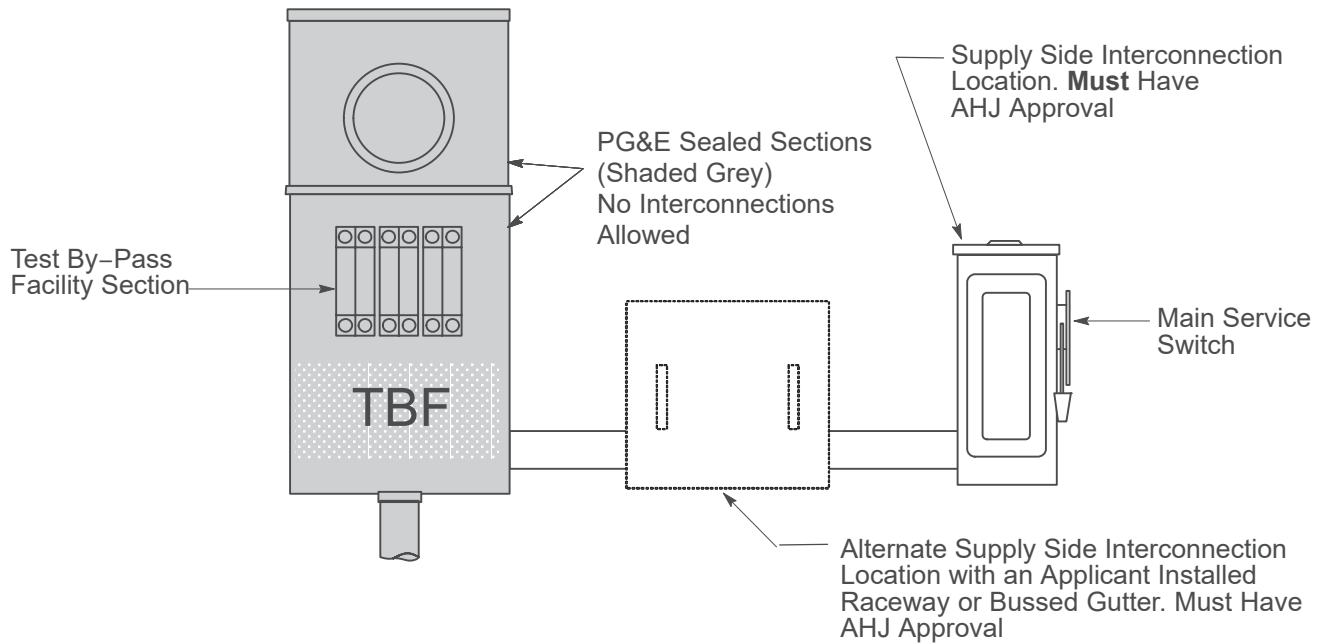
### Supply Side Interconnection Requirements for Distributed Generation

- 2. Do not route conduit and/or conductors through any PG&E sealed sections for the purpose of interconnection.
- 3. A fused AC disconnect switch must be installed within 10 feet and line of sight to the PG&E meter. Refer to [Document 060559](#) for AC disconnect requirements.
- 4. Figure 1 – Figure 7 on Pages 2 – 7 distinguishes the separation between PG&E and customer sections and the designated Supply Side Interconnection Locations. Interconnections are not allowed in any PG&E sections (shaded grey).

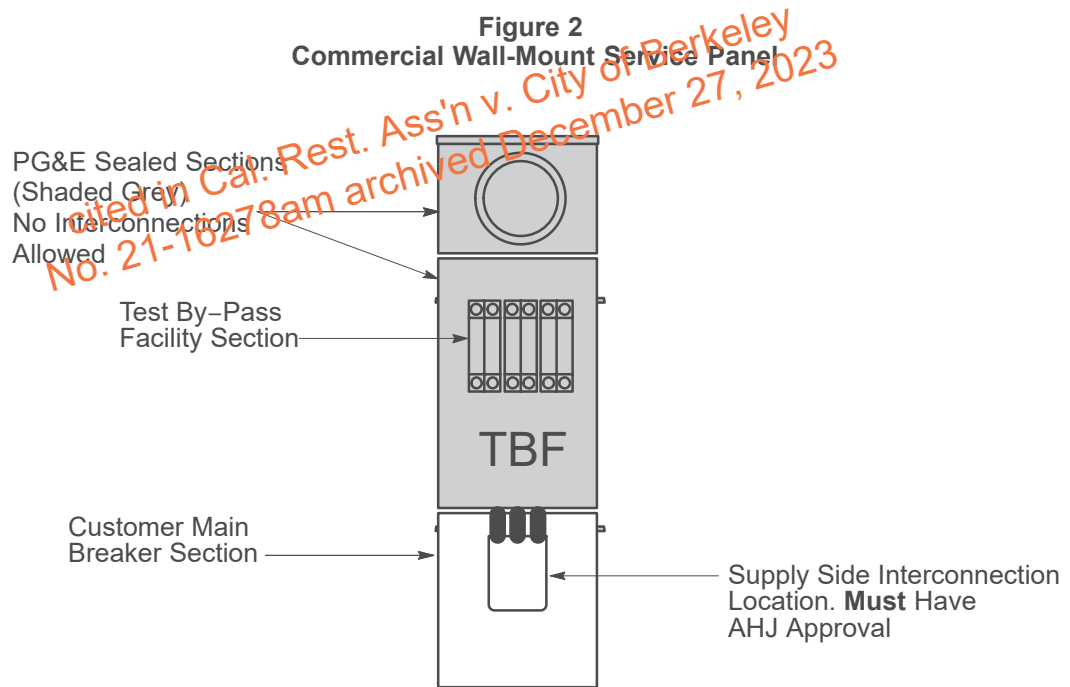


**Figure 1**  
**Residential Wall-Mount Service Panel**  
 Interconnections are not allowed in any PG&E sections (shaded grey)

**Supply Side Interconnection Requirements for Distributed Generation**

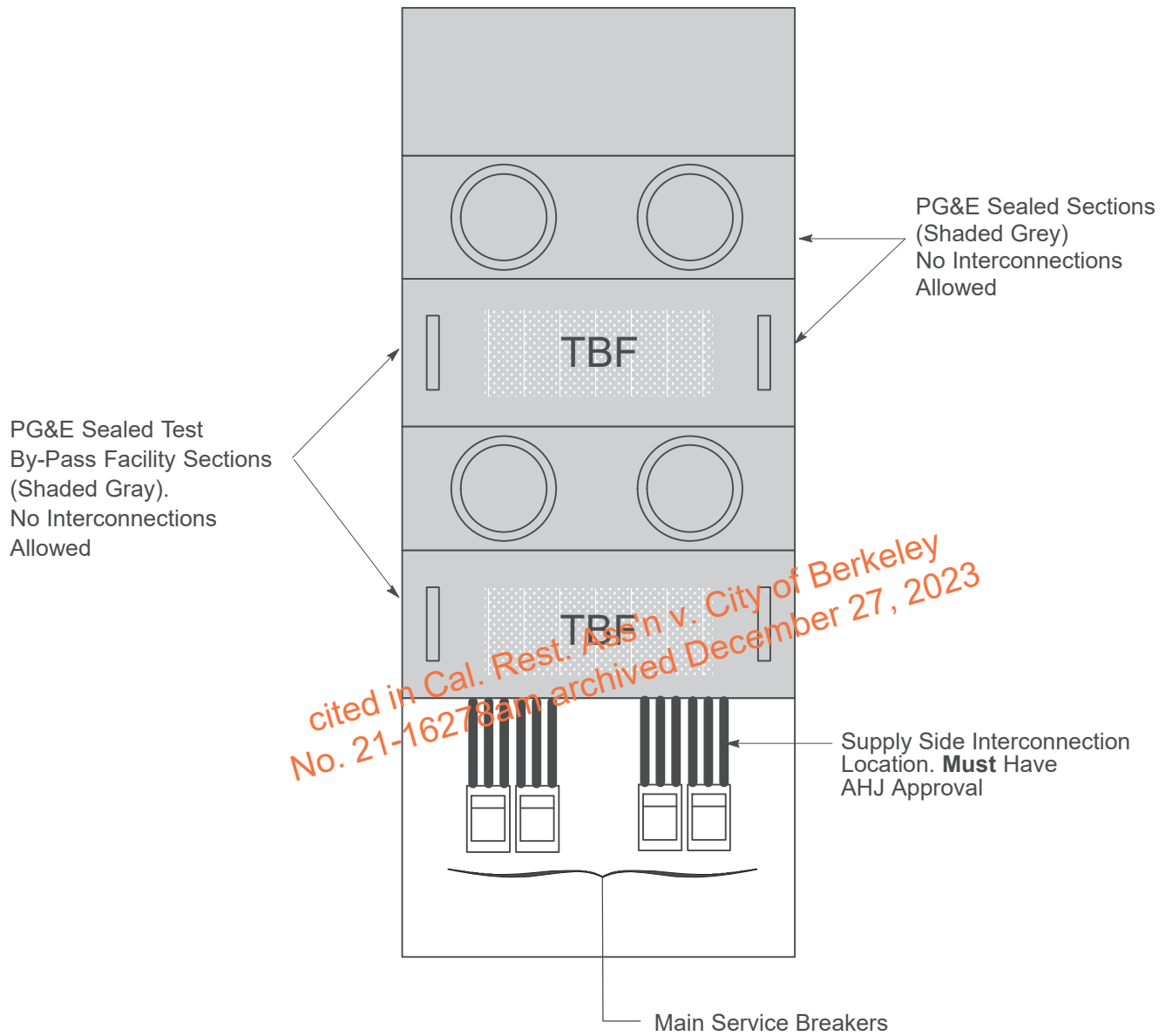


**Figure 2**  
**Commercial Wall-Mount Service Panel**



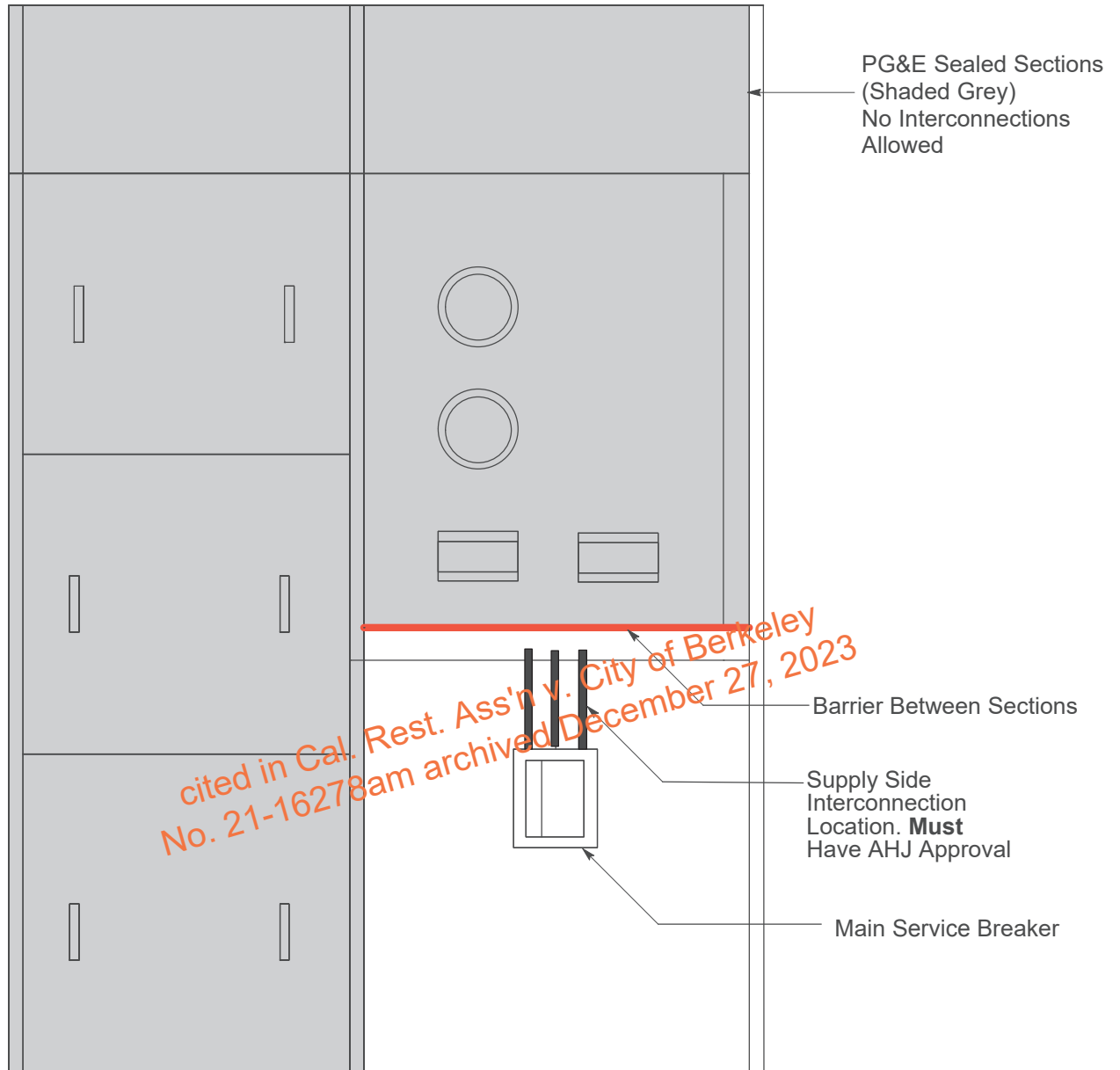
**Figure 3**  
**Commercial Wall-Mount Meter Breaker Combination Service Panel**  
Interconnections are not allowed in any PG&E sections (shaded grey)

### Supply Side Interconnection Requirements for Distributed Generation



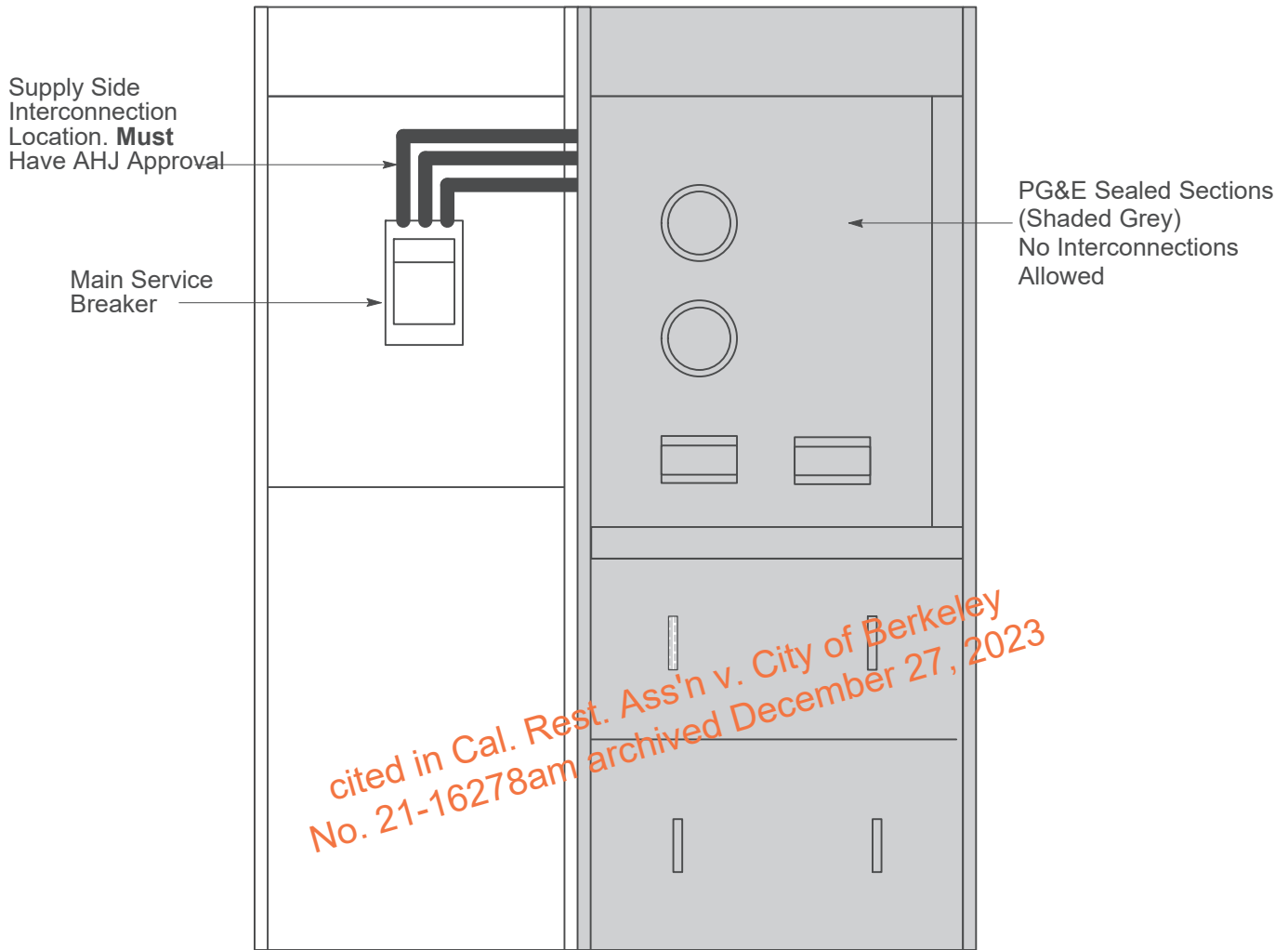
**Figure 4**  
**Commercial Floor-Standing Multi-Meter Switchboard**  
 Interconnections are not allowed in any PG&E sections (shaded grey)

### Supply Side Interconnection Requirements for Distributed Generation



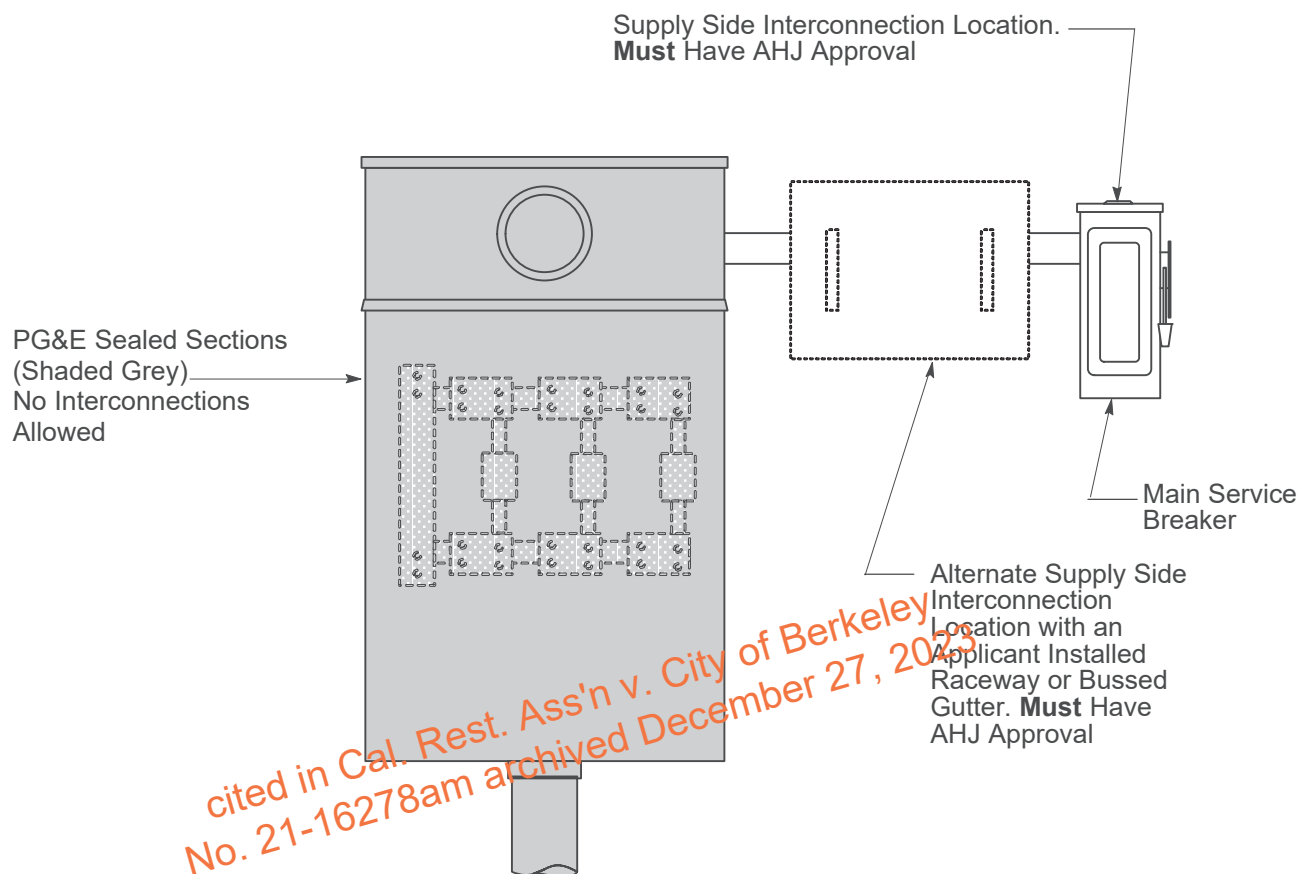
**Figure 5**  
**Floor Standing Switchboard With Metering Section Above the Main Breaker**  
Interconnections are not allowed in any PG&E sections (shaded grey)

### Supply Side Interconnection Requirements for Distributed Generation



**Figure 6**  
**Floor Standing Switchboard With Metering Section Above the Service Termination Section**  
Interconnections are not allowed in any PG&E sections (shaded grey)

## Supply Side Interconnection Requirements for Distributed Generation



**Figure 7**  
**Wall Mounted and Current Transformer Cabinet**  
 Interconnections are not allowed in any PG&E sections (shaded grey)

### Revision Notes

Revision 00 has the following changes:


1. This is a new document. This document replaces PG&E Bulletin TD-6999B-048, "Requirements for Line Side Interconnections for Distributed Generation".



cited in Cal. Rest. Ass'n v. City of Berkeley  
No. 21-16278am archived December 27, 2023

OH: Services  
 UG: Services  
 Greenbook

Prepared by: SXZO

	<b>PRIMARY ELECTRIC SERVICE REQUIREMENTS</b>		<b>094676</b>
	<b>Asset Type:</b> Electric Distribution <b>Issued by:</b> Daniel Jantz (DWJ7) <i>D. Jantz</i>	<b>Function:</b> Design, Estimating, and Field Metering <b>Date:</b> 3/25/2022	
<b>Rev. #00:</b> This new document replaces bulletin TD-2999B-030, Rev. #03. For a description of the changes, see Page 16.			

**Purpose and Scope**

This document specifies the technical requirements for all customers requesting electric service at one of Pacific Gas and Electric Company's (PG&E) primary distribution voltages as defined in Rule 2. It is intended to give the customer a clear understanding of what their responsibilities are to receive Primary Service (PS) and those of PG&E. PG&E has developed these technical requirements in order to provide safe and reliable service to all the customers the Company serves.

This document applies to load and generation PS customers. If the PS customer already has or intends to install distributed generation or back up generation, then also refer to the information described in the PG&E [Distribution Interconnection Handbook](#) (DIH). The DIH contains the specific requirements for interconnecting generating facilities or distributed generation (DG) with PG&E electrical distribution system.

**References**

References	Location	Document
<a href="#">25 kV Underarm Side-Break Switch, Manual and Automated</a>	OH:Switches	<a href="#">066195</a>
<a href="#">Installing Automatic Circuit Reclosers on Distribution Lines</a>	OH:Switches/EPM	<a href="#">066199</a>
<a href="#">Installation of Pad-Mounted Interrupters for Underground Distribution Lines</a>	UG:Switches	<a href="#">068188</a>
<a href="#">Introduction of the Eaton/Cooper-NOVA Pad-Mounted Line Recloser</a>	UG:Switches	<a href="#">076266</a>
<a href="#">Transmission Interconnection Handbook, Section G2, Protection and Control Requirements.</a>		
<a href="#">Electric &amp; Gas Service Requirements Manual (Greenbook)</a>		

Filed in Cal. Rest. Ass'n v. City of Berkeley  
 No. 21-16278am archived December 27, 2023

**Section 1 General Requirements**

Customers meeting the Rule 2 requirements for PS shall install, own, and operate their distribution system beyond their Point of Service (POS). While there are a number of technical requirements associated with a PS, two requirements are particularly important:

- PG&E must approve the POS.
- PG&E must approve the protection scheme that the customer installs, owns and operates at the POS.
- The maximum capacity of PG&E's primary distribution main line circuits is 600 amps. The maximum capacity of local loop distribution circuits is typically 200 amps. PS customers may be required to connect to a main line circuit if one or more customers are already connected to a local loop circuit as the capacity may be limited.

Additionally, the following information and requirements are also noteworthy.

- The PG&E system has an A-C-B counterclockwise rotation.
- Before making changes to PG&E-required protection equipment, the customer must submit the proposed changes to PG&E for review and approval.
- The customer is responsible for maintaining PG&E-required protection equipment in accordance with PG&E maintenance and test practices. A PG&E technical representative will reseal PG&E-required relays following setting changes and routine maintenance.

## Primary Electric Service Requirements

- After completing such tests, the customer must submit maintenance and test report documentation to PG&E for review and approval.
- Contact the local PG&E representative with any questions.

Satisfying these requirements assists PG&E in providing safe and reliable service to other customers connected to the Company's system. Customers considering a PS should contact PG&E early in the design process.

### Section 2 Primary Service Arrangements

PG&E prefers that the POS, protective device, and revenue meter for a PS be at or near the property line nearest to PG&E's primary distribution. The PG&E-approved and customer installed primary protection must be at the POS to protect other PG&E customers from outages due to faults on customer facilities. The revenue-metering should also be at this point because the PS customer is responsible for the line losses on their primary conductor and transformer(s) as well as their load. However, unlike the requirement for the protective device, it is not an absolute requirement.

The sections below explain the primary protection requirements and revenue-metering location requirements for PG&E's preferred PS arrangements. Please note that non-preferred service arrangement proposals may take longer to approve and involve additional cost for the customer.

### Section 3 Preferred PS Arrangements

PG&E's preferred PS arrangements are either: a) when the PS customer's primary distribution line is underground (UG) and the POS is less than 500 feet from the property line, or b) when the PS customer's primary distribution line is overhead (OH) and the protective device pole (if separate from the POS pole) is less than 50 feet from the property line.

#### 1. UG Conductor and POS < 500 Feet

If the PS customer's primary line is underground and the POS is 500 feet or less from the property line, refer to Figure 1 on Page 12 and Figure 2 on Page 13. The following requirements apply:

- The PS customer must provide a PG&E approved pad-mounted switchgear enclosure for PG&E's revenue-metering equipment. See Section 12 on Page 13 for detailed revenue-metering requirements.
- The PS customer must install primary protection at the POS. This protection may consist of a circuit breaker with phase and ground relays or, depending on the customer's load, fuses may suffice. If PG&E determines that fuses will not coordinate with PG&E's source-side protection, then the customer must use a circuit breaker. See Section 8A on Page 6 and Section 8C on Page 7 for circuit breaker and fuse requirements.
- The PS customer must install conduit from the POS to PG&E's primary distribution equipment location.
- PG&E will pull one continuous run of cable and connect to the customer's POS termination facility, not to exceed 500 feet (subject to an acceptable number of bends in the conduit).

#### 2. OH Conductor

If the PS customer's primary line is overhead, then the first pole at the customer's property line is the POS. Refer to Figure 3. The following requirements apply:

- PG&E will install pole-top revenue-metering on the first pole on the PS customer's property. See Engineering Standard [058779 Pole-Top Primary Metering Installation, \(12 or 21 kV Line\)](#) for pole-top revenue-metering requirements.
- The PS customer must install primary protection on the second pole on their property, not to exceed 50 feet from the revenue metering pole. This protection may consist of a recloser or, depending on the customer's load, fuses may suffice. If PG&E determines that fuses will not coordinate with PG&E's source-side protection, then the customer must use a recloser. See Section 8C on Page 7 for recloser requirements.
- The PS customer second pole and the equipment installed on it, must maintain a minimum clearance of 10 feet from the PG&E revenue metering pole and any equipment, crossarms, and wires installed on it.
- PG&E will interconnect its system with the customer's system at the revenue-metering pole.

### Section 4 Non-Preferred PS Arrangement Proposals

PS customers may propose a non-preferred PS arrangement. This typically occurs when the PS customer's primary distribution line is UG and the proposed location for the primary switchgear is greater than 500 feet from the property line. PG&E will consider such proposals; however, non-preferred service arrangement proposals may take longer to

## Primary Electric Service Requirements

design, approve, and can involve additional customer expense. Customers should contact PG&E early in the design process if they are considering a non-preferred PS arrangement.

Also, a non-preferred PS arrangement may consist of:

1. A PG&E approved interrupter within 500 feet of the property line, or
2. Pad-mounted switchgear greater than 500 feet of the property line that includes a protective device such as a breaker or fuses. In these cases, the substructures and equipment are installed and owned by the customer. As with preferred arrangements, PG&E must approve the location, substructure/equipment arrangement and protective devices.

In addition, The PS customer must provide space for PG&E's revenue-metering in their switchgear. See Section 12.B.5).a. on Page 15 for detailed metering requirements.

3. PG&E will pull one continuous run of cable, not to exceed 500 feet, to the POS (interrupter) subject to an acceptable number of bends in the conduit.

### Section 5 Location of Revenue – Metering

The preferred revenue meter location is at the POS. High-side metering is PG&E's preferred metering configuration. If PG&E approves low-side metering, a 2% adjustment factor will be applied at each stage of the transformation before the meter. See Section 12 on Page 13 for additional revenue-metering requirements.

### Section 6 Service Wire Configuration

If the PG&E POS is at a protective device and not at the customer owned switchgear the wiring configuration, 3-wire or 4-wire, of the customer's service from the protective device to the switchgear must be the same as PG&E's.

### Section 7 General Protection Requirements

It is important to minimize the potential hazard to life and property when interconnecting facilities to the PG&E distribution system. This requires the automatic detection of abnormal conditions and trouble related to a PS customer's equipment and the isolation of the condition and/or equipment within a reasonable time.

As a general rule, neither party should depend on the other for system protection. As such, PG&E's minimum protection requirements are designed and intended to protect the PG&E power system only. Moreover, the interconnection of a PS customer to the PG&E distribution system must not degrade existing PG&E protection and control schemes or interfere with the service of other customers (see Rule 2). The PS customer's facilities must isolate any fault or abnormality that could adversely affect the PG&E electric system, or the electric systems of other entities connected to the PG&E electric system.

PG&E assumes no liability for damage to the PS customer-owned facilities resulting from a lack of adequate coordination between the PS customer's protective device(s) and PG&E's protective devices, or negligence due to the PS customer's failure to maintain protective and/or isolation equipment.

PG&E recommends that the PS customer acquire the services of a qualified and licensed electrical engineer to review its plans. The PS customer must, at its expense, install, operate, and maintain system protection facilities in accordance with all applicable regulatory rules and requirements, and in accordance with this document.

1. Data the PS Customer Provides to PG&E
  - A. The PS customer must provide the information necessary for PG&E to determine the interconnection requirements before PG&E approves the specific PS installation. This information includes, but is not limited to, the following:
    - (1) Single-Line diagrams.
    - (2) Meter and Relay diagrams.
    - (3) Three-Line diagrams of required protective device.
    - (4) Control diagrams including direct current (dc) tripping circuit.
    - (5) Proposed relay specifications and settings.
    - (6) Relay manufacturer, model, style, type, ranges, settings, and a copy of the relay instruction manual.
    - (7) Projected electrical demand (i.e., kilowatt [kW]), including the following information:
      - (a) Power factor
      - (b) Load factor

**Primary Electric Service Requirements**

- (c) Large motor sizes
  - (d) Motor starting currents
  - (e) Customer's transformer size
  - (f) Estimated breakdown of the electric energy use (i.e., kilowatt hours [kwh]) by month
  - (8) Full-size phase and ground coordination curves showing full coordination with PG&E's system.
  - (9) A registered electrical engineer must prepare and stamp the fault-study results.
  - (10) Maintenance program documentation for PG&E-required switches, interrupting devices, and protective equipment.
  - (11) Completed [PS-1 Form](#) with main breaker(s) and relay data.
  - (12) Main Protective Relay Current Transformer(s) (CT) data;
    - (a) Manufacturer
    - (b) Model Number
    - (c) CT Ratio
    - (d) CT Class (Minimum Class C100 Required)
    - (e) CT Burden (Value must be provided in Ohms)
- B. PG&E strongly recommends that the PS customer, or their representative, provide the above information before ordering equipment and finalizing the design.
- C. Also, before energizing the new PS facility, the PS customer must also provide a copy of the on-site test reports for the switches, devices, and relays at least 30 working days before energizing the service. This allows sufficient time for review, modification, and final PG&E approval. Qualified personnel must prepare these on-site test reports. Refer to Section 9, "Equipment Test Requirements," on Page 6 and Section 10, "Pre-Energizing Test" on Page 8 for further details.
2. Data that PG&E Provides to the Applicant
- PG&E provides the following engineering data to the PS customer:
- A. System fault-duty at the property line.
  - B. Settings for PG&E source-side protective devices and the required clearance time to comply with PG&E protection standards.
  - C. Relay curves for PG&E source-side protective devices, if requested by the PS customer.

**Section 8 Specific Protection Requirements**

PG&E must review and approve the fault-interrupting devices that the PS customer selects. There are four basic types of fault-interrupting devices available for distribution systems:

- Circuit breakers
- Reclosers (without bypass)
- Interrupters
- Fuses

The following sections provide specific requirements for each of these devices.

**1. Circuit Breaker Requirements**

The interconnecting circuit breaker must have sufficient capacity to interrupt the maximum available fault current at its location. Phase and ground relays approved by PG&E (see Table 1, PG&E Approved Relays, on Page 7) must be used to trip the circuit breaker for phase and ground faults. These relays must coordinate with PG&E's source-side protection. It must also include the following features:

- A. Shunt-trip via a trip signal supplied through a battery external to the circuit breaker.
- B. Lock out if operated by protective relays required for interconnection.

## Primary Electric Service Requirements

C. Capacitive tripping is unacceptable.

D. Relay Requirements:

- (1) PG&E requires PS customers to install phase and ground over-current relays that trip the interrupting device at the POS. These relays must detect all phase and ground faults, and coordinate with PG&E's source side protection. All required relays must include relay targets and have "manual reset" capability.
- (2) The PS customer must either:
  - (a) select phase and ground relays approved by PG&E or,
  - (b) have an International Electric Testing Association certified testing company test the relay and provide the test results to PG&E for review. This option should be discussed with PG&E prior to testing the relays.
- (3) PG&E strongly recommends that PS customers submit all relay specification and setting proposals for PG&E approval before finalizing the design and ordering equipment. PS customers not submitting this information risk delaying their projects.

**Table 1 PG&E Approved Relays**

See Tables G2-4 and G2-5 located in the [Transmission Interconnection Handbook, Section G2, "Protection and Control Requirements."](#) These tables list all types of relays approved for load and generation interconnections on the PG&E distribution and transmission systems.

**NOTE:** PG&E's approval of the relays does not indicate the quality or reliability of a product or service. No endorsements or warranties are implied.

E. Relay Redundancy Requirement

The PS customer's protection system must contain redundancy such that the failure of any one component will still allow the customer's system to isolate the PS facility from the PG&E system under a fault condition. Three single-phase over-current relays and a ground over-current relay, or two three-phase over-current relays and a ground over-current relay satisfy the redundancy requirement. PS facilities, using microprocessor-based relays as a multifunctional protective device, must have backup relays.

F. Power Supply Requirements

- (1) Power supplies for PG&E required relays and the tripping circuitry for the fault-interrupting device must be supplied from a battery and charger system. The system must include dc under-voltage detection.
- (2) Fuses are not allowed in the dc trip circuitry (dc breakers are acceptable).
- (3) The preferred battery type is flooded lead-acid (calcium, antimony) or nickel-cadmium (NiCd). Sealed batteries (Valve Regulated Lead Acid [VRLA]) are not allowed. An uninterruptible power supply (UPS) is unacceptable. See Section 14, "Battery Requirements for Interconnecting to the PG&E System," on Page 10, for more details on PG&E's battery requirements.
- (4) The power supply system must include an alarm feature supplied from a DC low voltage source and connected to a customer monitoring system. The alarm must be audible and visual (strobe) and be operational at all times.

G. Fire Pump Circuit Breaker

Fire pumps connected to a separate circuit breaker that are not protected by the PS main circuit breaker are considered a second and independent main circuit breaker and therefore must meet all of the protection requirements in Section 8.1.

2. Reclosers and Interrupters

Contact PG&E for approved reclosers and interrupters.

When a recloser is used as the customer's primary protection, do not install a bypass switch or other type of equipment which bypasses the protective functions of the recloser. PG&E does not allow the customer's primary fault-interrupting device to be temporarily or permanently removed or bypassed at any time.

## Primary Electric Service Requirements

### 3. Fuse Requirements

- A. Fuses are single-phase, direct-acting, sacrificial links that melt to interrupt fault current and protect the equipment.
- B. PG&E may approve the use of fuses as the fault interrupting device at the POS for load-only facilities if the fuses coordinate with the PG&E source-side devices for both phase and ground faults. Large primary fuses that do not coordinate with PG&E's source-side protective phase and ground relays are not allowed. These fuses may cause other customers on the circuit to lose power due to a fault inside the PS customer's facility.
- C. If the facility has a generation source refer to the [Distribution Interconnection Handbook](#) for limitations on when fuses may be used as the fault interrupting device.
- D. The PS customer must replace the blown fuses manually after each fault before the facility can return to service. Only trained, qualified personnel should replace the primary fuses.
- E. If PG&E approves the fuses, the PS customer should consider installing a negative-sequence relay and/or other devices to protect its facility against single-phase conditions (however, this is not a requirement). The PS customer is responsible for protecting their equipment against single phase conditions, if they determine or feel that it is needed.
- F. Customers must keep a full set of replacement fuses (PG&E must approve the size and type) onsite.
- G. Solid Blade cutouts are not fuses and therefore not acceptable as a fault-interrupting device.

### 4. Replacement or Failure of Protective Equipment

When the customer's primary protection device malfunctions or fails to detect abnormal service conditions and trouble related to a PS customer's equipment and the isolation of the condition and/or equipment within a reasonable time then PG&E may require the equipment to be replaced. Also, when protective equipment is repaired or replaced the equipment must meet all of the qualification and testing requirements in this document including passing inspection by PG&E personnel. If new equipment is installed it must be currently listed as PG&E approved.

### Section 9 Equipment Test Requirements

The tests in this section apply only to the PG&E required equipment at the POS; specifically, the breaker, the relays, and the tripping circuitry.

The customer must complete the following requirements:

- The equipment must pass all the tests described below.
- The customer must submit two copies of the test reports to PG&E a minimum of 30 working days before energizing the PS facilities.
- Each test report must identify the equipment tested and that identification must match that in the single-line or three-line diagrams.

The customer must meet the above requirements and obtain PG&E approval of the test reports at least ten working days before PG&E energizes the PS. PG&E strongly recommends that the PS customer coordinate the test program with PG&E.

#### 1. Circuit Breaker Tests

The PS customer must perform the following circuit breaker tests:

- A. Minimum-to-trip test at 70% or less of the nominal control voltage on all circuit breakers operated by PG&E-required relays.
- B. Micro-ohm test on the main circuit breaker(s) at the POS.
- C. Timing test showing the time from the trip initiation to the opening of the main poles. Proving insulation tests, as described below.
- D. Proving Insulation
  - (1) Megger circuit breaker(s) at the POS operated by PG&E require relays (see Table 2 below).

**Primary Electric Service Requirements****Table 2 Circuit Breaker Positions and Connections**

Circuit Breaker Position	Connection
Circuit breaker open.	Each pole to ground, pole 1 to 2, pole 3 to 4, pole 5 to 6
Circuit breaker closed.	Pole 1–ground, pole 3–ground, pole 5–ground
If the poles are in a common tank or cell.	Pole 1 to 3, pole 3 to 5, pole 5 to 1

(2) Megger (phase-to-phase and phase-to-ground) all buses from the POS to the main breaker or fuses.

(3) The main circuit breaker(s) must have a dielectric test performed on the insulating medium (gas or oil). This test is not required for factory-sealed, circuit-switcher interrupters.

## 2. Tests for Current Transformers and Current Circuits

PS customers must perform the following tests for current transformers (CTs) and current circuits associated with PG&E-required relays:

- A. Check the saturation on all CTs. If this is not possible, a manufacturer's curve is acceptable.
- B. Prove the ratio of all CTs by using current (primary to secondary) or voltage (secondary to primary).
- C. Check the CTs for the proper polarity.
- D. Check the CT circuits for the proper connections.
- E. Check the continuity of the CTs by:
  - (1) Applying primary or secondary current at the CT block.
  - (2) Verifying that the proper current exists in each phase relay and the ground relay.

Customers must perform each test (primary or secondary) in all combinations prove that all phase relays and ground relays have proper connections.

PS customers must also ensure that no loose wiring or parallel current paths exist, by applying or injecting the current to achieve a secondary reading of 5 amperes (A) in each relay.

Check each phase of each current circuit feeding PG&E-required relays. Megger the total circuit with the ground wire lifted (to prove that only one ground exists).

## 3. Relay and Fuse Tests

The testing requirements for relays/fuses include:

A. PS customers must field test the settings of PG&E required relays to verify the following items:

- (1) The minimum operating point at which the relay picks up (minimum pickup).
- (2) Time delays at three different current-test points, in integral multiples of the minimum pickup that closely characterize the relay time-current curve.
- (3) Test results must be within the tolerances listed below:
  - (a) Current/Voltage/Time  $\pm 10\%$
  - (b) Impedance/Phase Angle  $\pm 0.05\%$
  - (c) Frequency  $\pm 0.05\text{ Hz}$

B. Check all fuses for continuity before energizing.

## 4. Tests Recommended (But Not Required by PG&E) for the PS Customers

### A. Transformer

It is recommended (but not required by PG&E) that the customer perform the following tests prove the insulation and turns ratio on their primary service transformers.



**Primary Electric Service Requirements**

## (1) Proving Insulation

A 1,000 or 2,500 volt (V) dc megger test or a 1,000 V, high-pot test is recommended for any of the insulation tests below.

- (a) Megger the main transformer(s) winding-to-winding and each winding-to-ground.
- (b) Megger the buses (phase-to-phase and phase-to-ground) from the POS to the main transformer.
- (c) Perform a dielectric test on the main transformer(s) insulating medium (gas or oil).

## (2) Proving Ratios

Prove the main transformer(s) ratio(s) using one of the following methods:

- (a) Turns-ratio tester.
- (b) Voltage-ratio test on the final operating tap. Consult with PG&E to best match the present distribution-system voltage.

**Section 10 Pre-Energizing Test**

1. Customers must meet the following requirements before PG&E will energize the PS:

- A. Ensure that any inspections required by local governmental and regulatory agencies are complete and any applicable permits are obtained before PG&E energizes the PS.
- B. A PG&E technical representative must witness trip checks of all PG&E-required relays. This may require injecting a signal to trigger the relay. This proves that the relay will handle the trip current of the circuit breaker. It also proves relay targeting. Jumpering the studs on the back of the relay is not acceptable.
  - (1) The Primary Service Entity shall provide all test equipment and qualified third party personnel to perform the required tests. PG&E recommends third party testers to be National Electrical Testing Association (NETA) certified. PG&E shall be there strictly as an observer. Form PS-7 shall be completed by the PG&E representative on site at the time of the pre-energizing test.
- C. A PG&E technical representative must verify grounds are bonded per standard (switching platforms, fences, buildings, etc.) and verify signage is correct per the below requirement. All signs shall be constructed to be weatherproof.
  - (1) Disconnect – The disconnect sign shall have 1 inch wide by 2 inch high, with colors venetian red (#3) lettering on a buff (#1) background (or similar). If the facility has multiple feeds with multiple separate disconnect switches, then each disconnect requires a separate sign.
  - (2) Location – The location sign shall have 1 inch high venetian red (#3) lettering on a buff (#1) background. PG&E's standard location sign size is 14 inches wide by 7 inches high overall. It shall be posted at each entrance to the facility. If there are other gates or doors to go through, then each one of those shall have a sign as well. For example: One posted at the entrance to the primary service facility, and one posted on the entrance to the substation within the primary service facility.
- D. After energizing the PS and adding load, a PG&E technical representative must witness the reading of the load current in each phase relay and the absence of load current in the ground relay. The PG&E technical representative will then seal the relays.
- E. The PS customer is responsible for providing all test equipment, and qualified personnel to conduct the tests in the presence of a PG&E technical representative.

**Section 11 Alternate Source**

A PS customer may request an alternate primary service source installed at customer expense. Requests for an alternate source are handled on a case-by-case basis. This section describes some of the technical requirements associated with installing and operating a PS with an alternate source. Technical requirements may change depending on location and a variety of other factors. PG&E strongly recommends that customers contact the Company early in the design phase to ensure a successful project. The PS customer and PG&E must work together to ensure that an alternate source system fulfills the customer's needs while not degrading PG&E protection schemes, operating flexibility, or cause interference with another customer's service.

When a PS load is transferred from the primary source to the alternate source or vice versa, a momentary outage ("drop-and-pickup" operation) occurs.

## Primary Electric Service Requirements

When the PS is fed from the alternate source and the PS customer wants to transfer back to the primary source with a parallel operation (“make-before-break” method), the PS customer must meet the following requirements:

- F. The ratios and electrical connections of the transformers on both sources must be well matched to minimize circulating currents.
- G. The impedance of the transformers and the relative phase angles of the sources must be such that any “through load” (i.e., flowing of power through the PS customer’s electrical system to other customers) does not cause overloads.
- H. The parallel transfer operation must not degrade protection, inhibit PG&E’s operating flexibility, or overstress equipment (customer or PG&E equipment).
- I. The transfer switches, one on each side of the PS load, require an automatic interlock control scheme to minimize the time the two systems are paralleled. The transfer switches must be circuit breakers or other suitably rated, automatically controlled switches.

### NOTE

The parallel period must be less than one second because the presence of two parallel circuits will increase the fault duty and may overstress the PS customer’s equipment.

- J. In some cases, PG&E may require additional protective devices and/or special operating procedures to ensure safe and reliable service for the PS customer and other PG&E customers.
- K. Each parallel transfer operation can only proceed after PG&E’s specific approval. The PS customer must obtain PG&E’s approval before performing the parallel transfer operation. PG&E may withhold approval if, in its sole judgment, the above requirements have not been met, or if a previously unforeseen factor or change in conditions is deemed to jeopardize the operator, public safety, or reliability to customers.
- L. The PS customer must assume all liability for any problems or damage resulting from any parallel transfer operation.

### Section 12 Revenue-metering Requirements

This section addresses direct access (DA) and bundled-service PS customers connected at distribution voltages (34.5 kV and below), as described in Rule 2. Customers must satisfy PG&E’s revenue-metering requirements and those of other applicable governing authorities (i.e., California Public Utilities Commission [CPUC], California Independent System Operator [CAISO], etc.).

For customers exporting power, loads connected at distribution voltages must satisfy the metering protocols established by PG&E and CAISO. Exceptions are handled on a case-by-case basis with approval from PG&E’s Meter Engineering department in close coordination with Field Metering Services.

Other arrangements that affect the required metering installation may also require a “Generation Special Facilities Agreement.”

There are two types of distribution services:

- Wholesale
- Retail (i.e., end-users)

#### 1. Wholesale Service

- A. For wholesale-service interconnections, please refer to the [Wholesale Distribution Tariff \(WDT\)](#) and document [092816 Wholesale Distribution Tariff \(WDT\) Interconnection Design Options for Primary Voltage Service](#)
- B. For the revenue metering of the wholesale-service interconnections, the PS customers must provide, install, own, and maintain all revenue-metering-related equipment, including all the items provided and maintained by PG&E or a Meter Service Provider (MSP) listed under “Retail Service” below.
- C. PS customers requesting wholesale service must meet the following criteria:
  - (1) CAISO metering standards
  - (2) PG&E’s requirements

**Primary Electric Service Requirements**

- (3) Enter into a Meter Service Agreement (MSA) with the CAISO and, in certain cases, with PG&E. The MSA specifies requirements regarding the retrieval of load data and accessibility by CAISO.
- D. The wholesale PS customer is responsible for ensuring that the meters comply with CAISO's meter standards and accuracy requirements.
- E. All PS customers must contact PG&E's local account services representative for PG&E's revenue-metering requirements.
2. Retail Service (End Users)
- [Electric Rule 22](#) governs the interconnection and operating requirements for DA customers. Please use the following link to access the document, [https://www.pge.com/tariffs/assets/pdf/tariffbook/ELEC\\_RULES\\_22.pdf\\_for\\_the\\_following\\_elections](https://www.pge.com/tariffs/assets/pdf/tariffbook/ELEC_RULES_22.pdf_for_the_following_elections).
- A. Customer service elections
- B. Customer metering options
- C. Customer Responsibilities

The customer (end-user) maintains the following:

- (1) The (pad-mounted) primary switchgear
- (a) Please refer to [PG&E's Electric and Gas Services Requirements](#) (<http://www.pge.com/greenbook>) [Section 11](#) for primary switchgear requirements and to [Section 5](#) for their general requirements of all metering equipment.
- (b) The ampacity rating of primary switchgear should not exceed 600 amps. This supply rating must be listed on the switchgear nameplate. As this is the maximum rating of PG&E's primary distribution main line circuits. Also note that some circuits may be de-rated to less than 600 amps due to the PG&E installed distribution wire size and distribution equipment ratings.
- (c) To maintain the required metering accuracy and to meet PG&E requirements, the revenue-metering instrument transformers must be located in the same switchgear with the revenue meters.
- (d) The enclosure must be grounded and if applicable, located within the substation ground grid.
- (e) Access must be readily available for PG&E employees to read and maintain the metering equipment
- (2) Overhead PS

Refer to Engineering Document [058779](#), "[Pole-Top Primary Metering Installation, \(12 or 21 kV Line\)](#)." for metering requirements of overhead primary services.

**Section 13 Communication Circuits**

PG&E may require communications circuits between PG&E and the customer's PS facilities for the following purposes:

- Protection
- Revenue Metering
- Energy Management System (EMS)
- Supervisory Control and Data Acquisition (SCADA)
- Generation
- Voice communications

When external communication circuits are installed, the responsible party must ensure that the high-voltage protection (HVP) equipment on these circuits meets all applicable standards.

**Section 14 Battery Requirements for Interconnecting to the PG&E System**

This section describes PG&E's process for ensuring safety and reliability of for customers who connect to Company systems. The recommendations made here will ensure that the system operates as designed.

1. Because of reliability and safety reasons only flooded lead acid (calcium, antimony) and Nickel-Cadmium (NiCd) batteries are acceptable in switchgear installations.

## Primary Electric Service Requirements

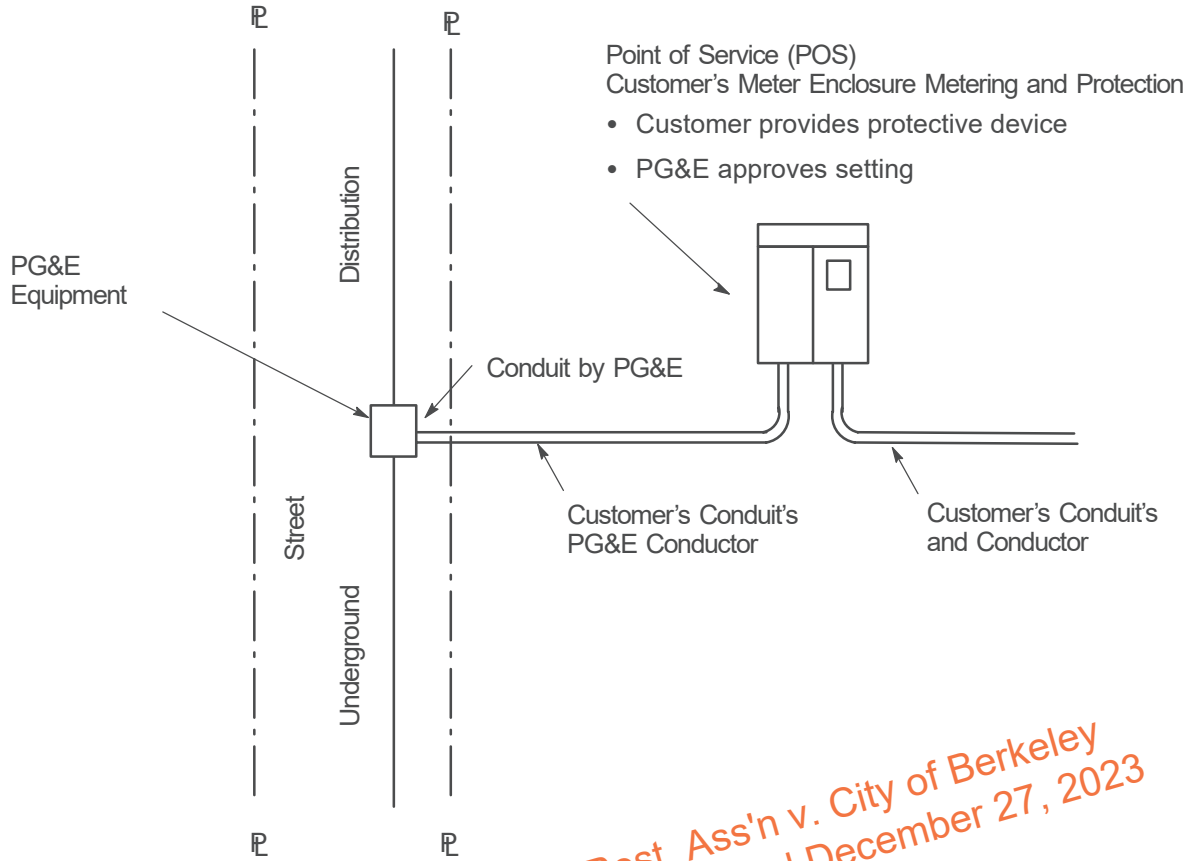
2. It is required for the third party customer to provide the following documentation to PG&E for review and acceptance by the Substation Engineering Department:
  - A. Complete [FORM AT-1](https://www.pge.com/includes/docs/pdfs/shared/rates/tariffbook/ferc/tih/app_t.pdf), "Third Party Interconnection Battery Information Sheet and Acceptance Document" ([https://www.pge.com/includes/docs/pdfs/shared/rates/tariffbook/ferc/tih/app\\_t.pdf](https://www.pge.com/includes/docs/pdfs/shared/rates/tariffbook/ferc/tih/app_t.pdf)), located on pages 4 thru 5 in Appendix T on the [Transmission Interconnection Handbook](#) webpage.
  - B. Type of Battery (Vented Lead Acid-VLA or NiCd). Monoblock (multiples cells in a jar) batteries from C & D, EnerSys or other vendors will be acceptable. Battery racks must be designed to withstand loading based on IEEE 693 (High Seismic).
  - C. Detail information of load including continuous and momentary. No minimum requirement- Smallest flooded acid may be the limitation.
  - D. Battery sizing calculation based on IEEE Standard 485-2010 (IEEE recommended Practice for Sizing Large Lead Storage Batteries for Generating Stations and Substations) or IEEE Standard 1115-2014 (IEEE recommended Practice for Sizing Nickel-Cadmium Batteries for Stationary application) and minimum 8 hours discharge rate using manufacturer software (to ensure proper discharge curve is used) using aging factor of 1.25 and design margin of 1.1 to be clearly shown on the calculation. Charger sizing calculation based on battery size with recharge time of 12 hours assuming charger will support the continuous load as well as recharges the battery at the same time.
  - E. When battery is installed proof of three (3) hour discharge testing to ensure battery has the capacity to support the load and trip; per IEEE Standard 450-2010 (Voltage measurements should be taken every 15 minutes throughout the testing).
  - F. Documentation showing what kind of maintenance will be done (Monthly, Quarterly, and Yearly etc.).
  - G. Monitoring of minimum battery low voltage by separate voltage relay or through charger and provide critical audible and visual alarm for the monitoring system.

### Section 15 Preferred Service Arrangement Figures

The following pages provide figures showing the preferred service arrangements for overhead and underground primary services.

*cited in Cal. Rest. Ass'n v. City of Berkeley  
No. 21-16278am archived December 27, 2023*

### Primary Electric Service Requirements

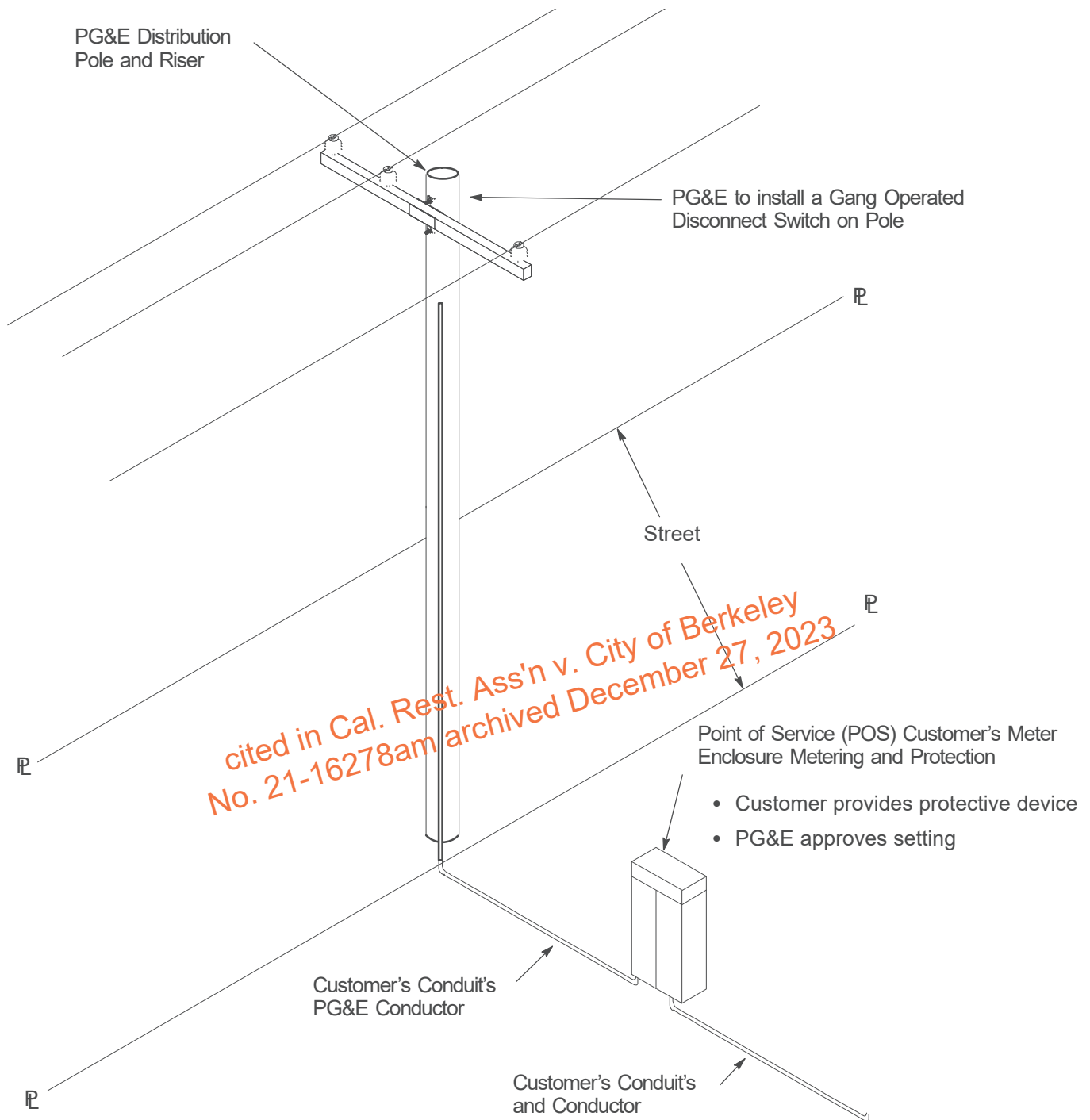


**Notes:**

1. PG&E will install a protective device under a special facilities agreement if there are extenuating circumstances that prevent the customer from installing one. This is an exception and will be handled on case-by-case basis.
2. PG&E will own and maintain substructures in the franchise area and the customer will own and maintain substructures on private property
3. PG&E will provide one continuous pull of cable to POS, not to exceed 500 feet.

**Figure 1**  
**Underground Primary Service from Underground Distribution Preferred Service**  
**Arrangement Switchgear > 500 feet from PG&E Equipment**

## Primary Electric Service Requirements

**Notes:**

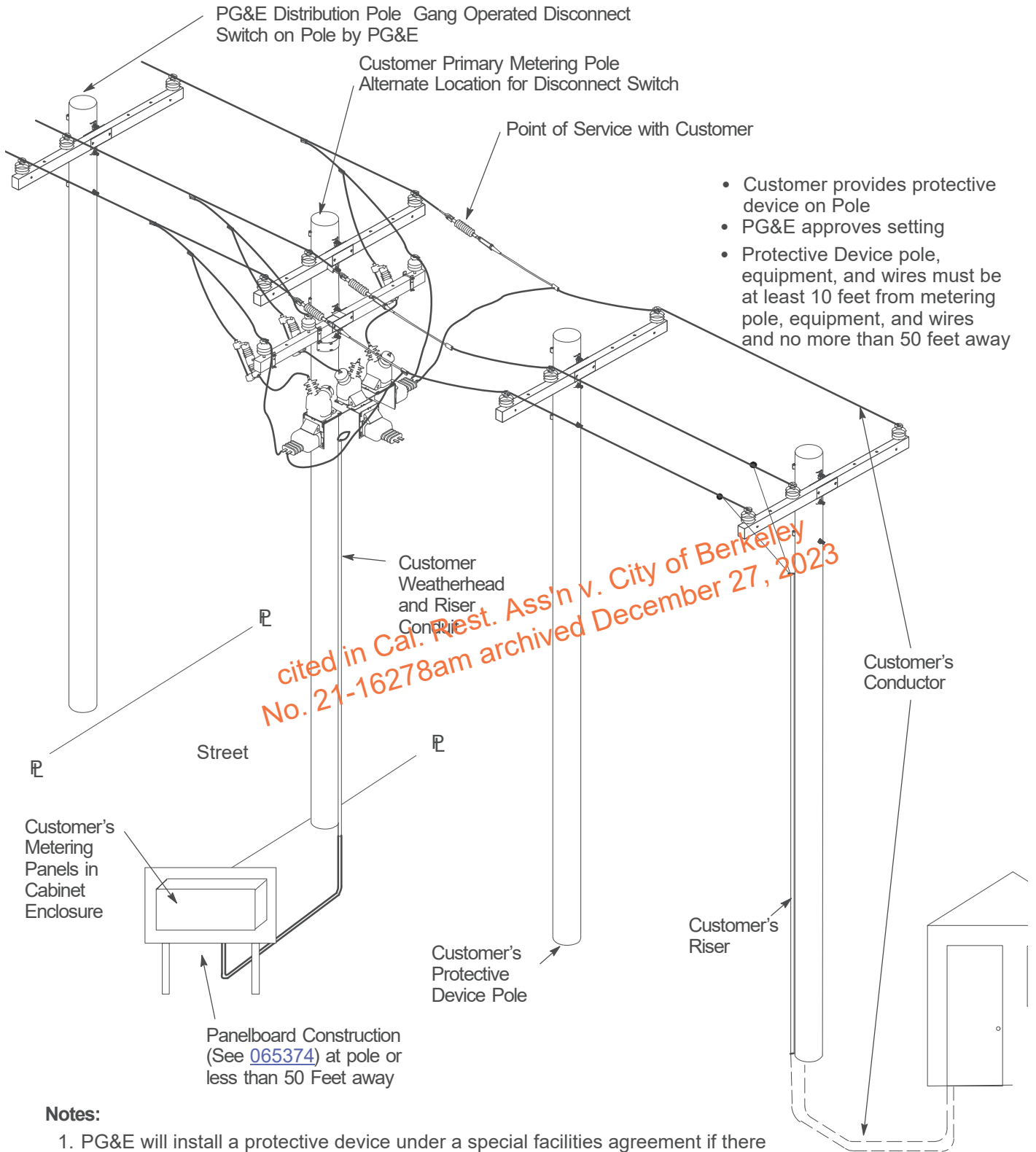
1. PG&E will install a protective device under a special facilities agreement if there are extenuating circumstances that prevent the customer from installing one. This is an exception and will be handled on case-by-case basis.
2. PG&E will own and maintain substructures in the franchise area and the customer will own and maintain conduit on private property.
3. PG&E will still provide one continuous pull of cable to POS, not to exceed 500 feet.

**Figure 2**

**Underground Primary Service from Overhead Distribution Preferred Service Arrangement  
POS  $\leq$  500 feet from PG&E Pole**

OH: Services  
UG: Services  
Greenbook

### Primary Electric Service Requirements

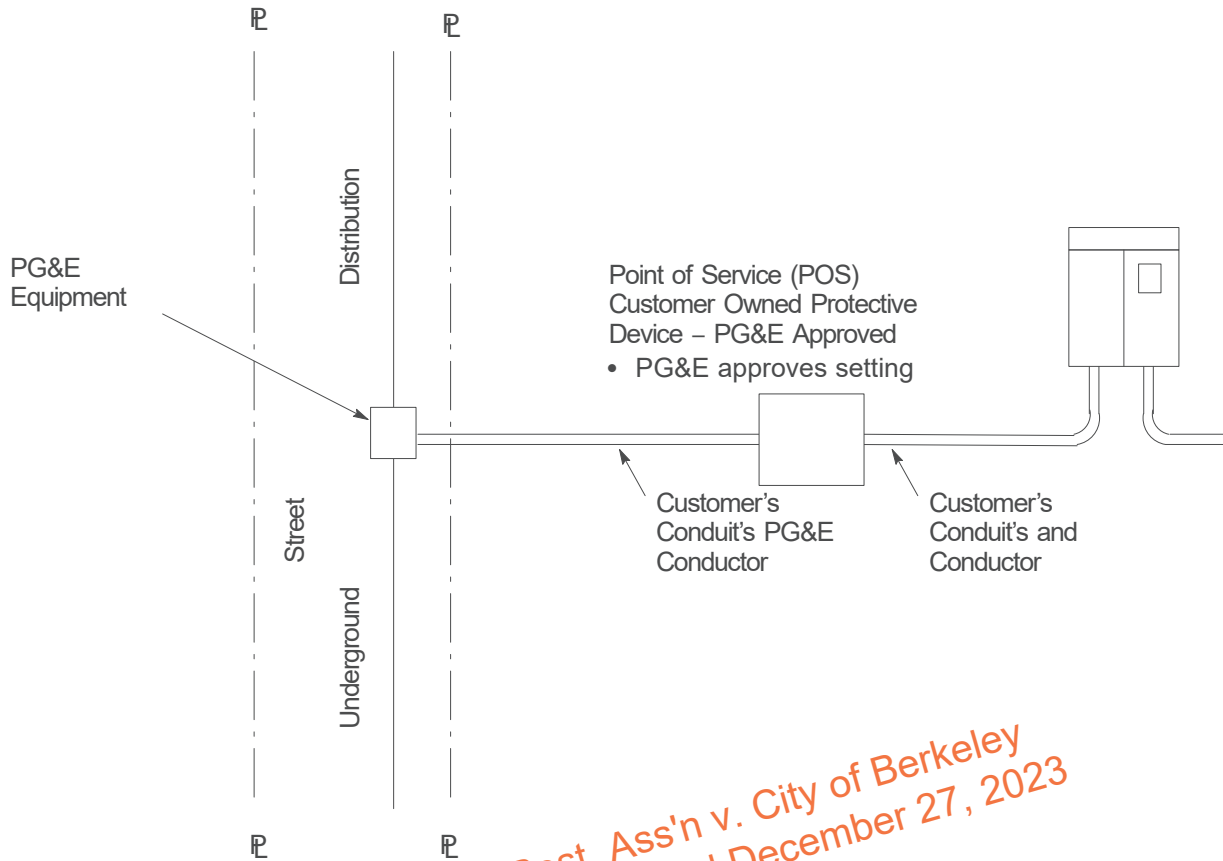


**Notes:**

1. PG&E will install a protective device under a special facilities agreement if there are extenuating circumstances that prevent the customer from installing one. This is an exception and will be handled on case-by-case basis.

**Figure 3**  
**Overhead Primary Service From Overhead Distribution Preferred Service Arrangement**

## Primary Electric Service Requirements

**Notes:**

1. PG&E will install a protective device under a special facilities agreement if there are extenuating circumstances that prevent the customer from installing one. This is an exception and will be handled on case-by-case basis
2. PG&E will own and maintain substructures in the franchise area and the customer will own and maintain substructures on private property.
3. PG&E will provide one continuous pull of cable to POS, not to exceed 500 feet.

**Figure 4**  
**Underground Primary Service from Underground Distribution Non-Preferred**  
**Service Arrangement Switchgear > 500 feet from PG&E Equipment**



**Primary Electric Service Requirements**

---


**Revision Notes**

Revision 00 has the following changes:

1. Converted Bulletin TD-2999B-030 to this new numbered engineering document.
2. Consolidated general requirements through document to Section 1 General Requirements on Page 1.
3. Added links and updated information throughout the document.
4. Updated Figure 1 on Page 12.
5. Updated Figure 2 on Page 13.
6. Updated Figure 3 on Page 14.
7. Added Figure 4 on Page 15.
8. Added Note 1.A.(11) on Page 4.

*cited in Cal. Rest. Ass'n v. City of Berkeley  
No. 21-16278am archived December 27, 2023*

Prepared by: SXZO

	<b>SMART METER ELECTRIC NETWORK REQUIREMENTS FOR INDOOR METER ROOMS AND HIGH-RISE BUILDINGS</b>		<b>094683</b>
	<b>Asset Type:</b> Electric Distribution	<i>D. Jantz</i>	<b>Function:</b> Design, Estimating, and Field Personnel
<b>Issued by:</b> Daniel Jantz (DWJ7)		<b>Date:</b> 3/25/2022	
<b>Rev. #00:</b> This new document replaces bulletin TD-7001B-005, Rev. #01. For a description of the changes, see Page 8.			

**Purpose and Scope**

This Document provides Smart Meter (SM) infrastructure installation and construction requirements for customers designing indoor electric meter rooms for high-rise buildings. This will address below-grade and multiple above-grade meter room installations such as those that may exist in an urban, high-rise environment to ensure PG&E's Smart Meter mesh network is established for these customers. These provisions are required for commercial and/or residential, single, or multiple, indoor meter rooms to ensure Smart Meter electric network communication access and performance.

**References**

References	Location	Document
<a href="#">Electric and Gas Service Requirements (Greenbook)</a> .....	City of Berkeley	<a href="#">TD-7001M</a>

**General Information**

1. To make sure customer's Smart Meters are connected to the Smart Meter mesh network, provisions must be made for access to mount equipment and pathways for radio frequency (RF) communications. It is important to make the necessary provisions for Smart Meter equipment early in the planning stage for high-rise or below-grade meter room situations to prevent additional costs from being incurred by customers and/or by PG&E. Special provisions to facilitate the installation of Smart Meter technology meters and equipment include:
  - A Access by PG&E personnel for placement of radio frequency equipment
  - B Path for radio frequency (RF) signal propagation (i.e., conduit)
  - C Placement of ancillary RF equipment (in-room relay or access point may be installed inside meter rooms or on the exterior of the building, including on the top of the building)
  - D Conduit and cable routing. Placement and mounting of antennas (MPACK or Salt-shaker antennas)

Please review the drawings on pages 3 through 7 which illustrate these required provisions.
2. The minimum requirements in this document must be met but should not preclude applicable building, fire, or electrical code requirements.
3. Because many of the buildings and situations where these provisions will be required are custom in nature, design plans must be submitted to your local service planner for review by the local meter shop and any other appropriate PG&E department. Communicating early in the design process will allow for additional site-specific review by the Smart Meter Operations Center (SMOC) Tier 4 Analyst(s).
4. Install 3" conduits from the main electrical room ceiling, where the PG&E service cables terminate into the switchboard or switchgear, to the floor above. Continue to install conduit, vertically aligned, in each floor and ceiling, with or without a meter room on the floor. The conduit must be installed upward to the floor with the highest meter room above grade. For example, if the main electrical room is one level below grade (B1) and highest meter room is on the 22nd floor; then install 3" conduit in each ceiling/floor from level B1 to floor 22.
5. All meter rooms must be vertically aligned in the building. Offset meter rooms are not allowed.

**Requirements for Figure 2, Figure 3, Figure 4 and Figure 5:**

6. Conduit Size: 3-inch in diameter.

## Smart Meter Electric Network Requirements for Indoor Meter Rooms and High-Rise Buildings

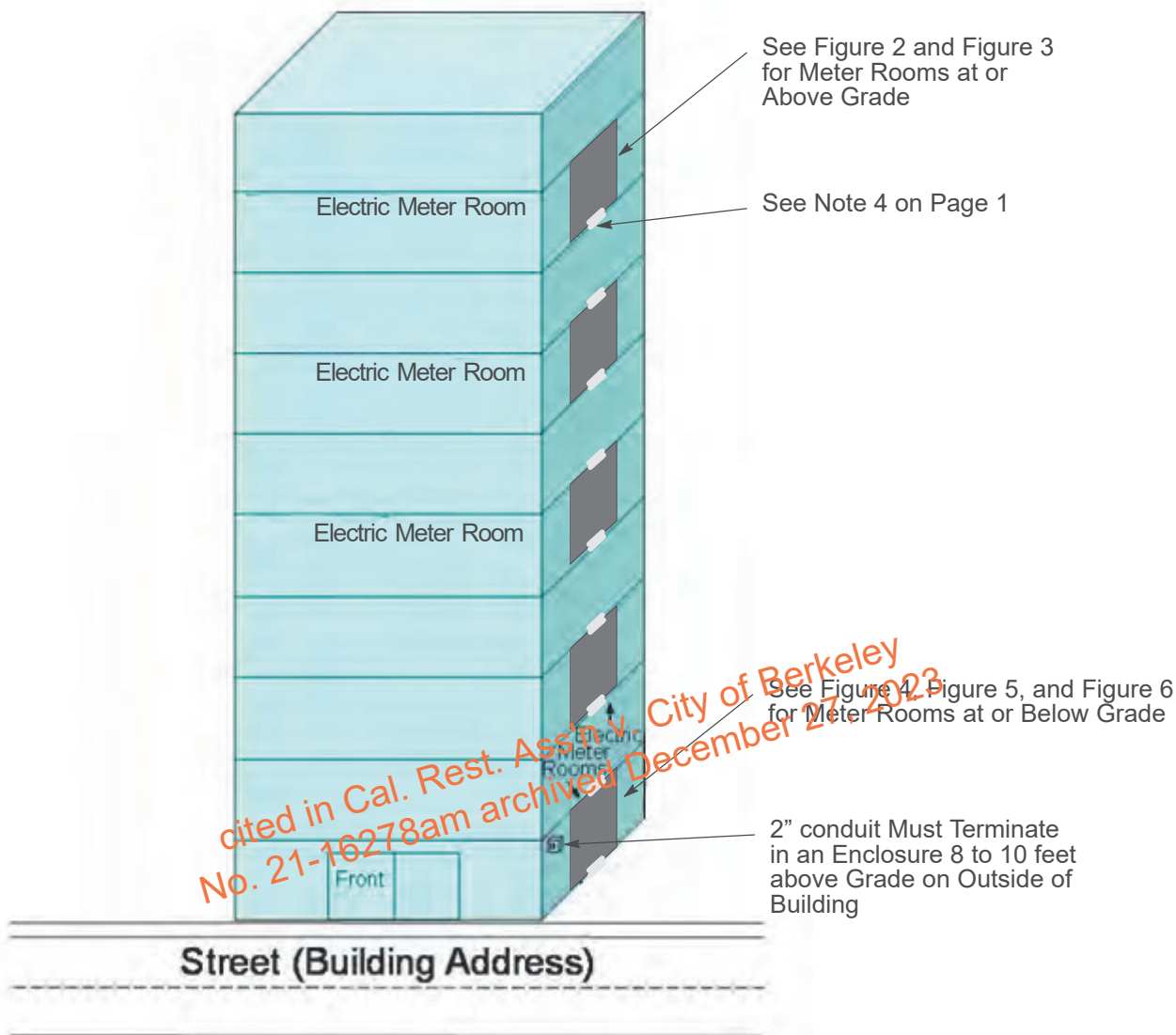
---

7. Conduit Type: Non-metallic Schedule 40 or better.
8. Conduit Caps: Non-metallic permanent caps, of the same conduit type and size, must be placed on both ends of the conduit. The cap ends should be flush with the ceiling or floor surface.
9. Firestop System: Install as required by local building, fire, or electrical code.
10. Conduit Placement: Inside the meter room. Preferably in front of the meter panel. The conduit must not be blocked by any equipment or objects. The conduit must not be covered with concrete or metal flooring.

### Requirements for Figure 4, Figure 5, and Figure 6:

11. Firestop System: Not required. Do not install.
12. Conduit Size: 2-inch in diameter. The total length of all conduits must not exceed 300 feet.
13. Conduit Type: Conduits installed, in walls, ceilings, floors, or concrete must be made of rigid steel. For all other locations the conduit type can be electrical metallic tubing (EMT) or better.
14. Conduit Cap: A temporary cap, of the same type and size as the conduit, must be placed on the end of the conduit next to the meter panel.
15. Conduit Termination Inside: The conduit must be terminated in a horizontal position on top of the meter panel section and 6 to 12 inches from the front of it. The conduit must **not** enter or pass through the switchgear or enclosure.
16. Conduit Termination Outside: The conduit must terminate in a horizontal position, inside a termination enclosure, on the outside building wall. The conduit must be 8 to 10 feet above grade level and protrude 1-inch outward from the wall.
17. Termination Enclosure: A minimum 6" x 6" x 6", NEMA 3R rated, with an accessible front cover. It must be permanently installed to the outside wall with the conduit terminated inside.
18. Conduit Bends: Any bend must have a minimum 12-inch radius.
19. Junction box: A minimum size of 12" x 12" x 4" is required for pulling when the total number of degrees of conduit bends exceeds 270 between end points or junction boxes. A junction box is also required when the conduit run length exceeds 100 feet. The total length of all conduits must not exceed 300 feet.
20. Pulling Tape: Rated for a minimum of 500 pounds and placed inside the conduit for its entire length from end to end to facilitate cable pulling.
21. Transformer Rooms: Conduit must **not** be installed inside of a transformer room.
22. Conduits can be installed in the floors, ceilings, or walls of the room.
23. Working Space: The open area that must be maintained around all switchboards, metering enclosures, and the outdoor conduit
  - A Above the entire top of switchboard or enclosure a minimum of 12 inches of vertical clearance.
  - B In front of the switchboard a minimum of 48 inches of horizontal clearance and extending to a height 12" above the switchboard or enclosure.
  - C In front of the location where the outdoor conduit terminates a minimum area of 36 inches deep, as measured from the outside building wall, by 30 inches wide and extending upward to 12 inches above the conduit.

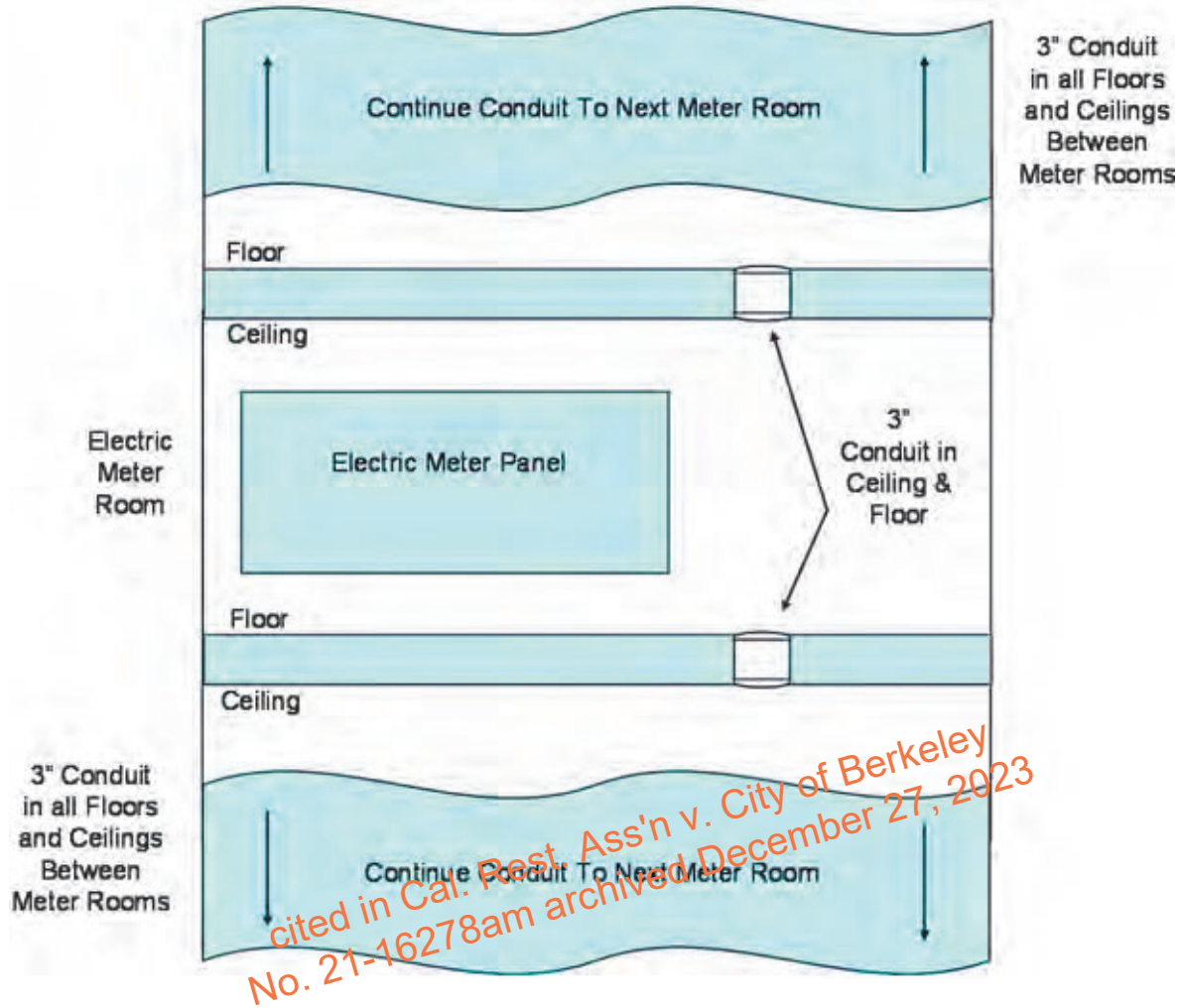
### Smart Meter Electric Network Requirements for Indoor Meter Rooms and High-Rise Buildings



*cited in Cal. Rest. Ass'n v. City of Berkeley No. 21-16278am archived December 27, 2023*

**Figure 1**  
**High Rise Building with Indoor Electric Meter Rooms**

### Smart Meter Electric Network Requirements for Indoor Meter Rooms and High-Rise Buildings



*cited in Cal. Post. Ass'n v. City of Berkeley  
No. 21-16278am archived December 27, 2023*

Figure 2  
Above Grade Meter Rooms

### Smart Meter Electric Network Requirements for Indoor Meter Rooms and High-Rise Buildings

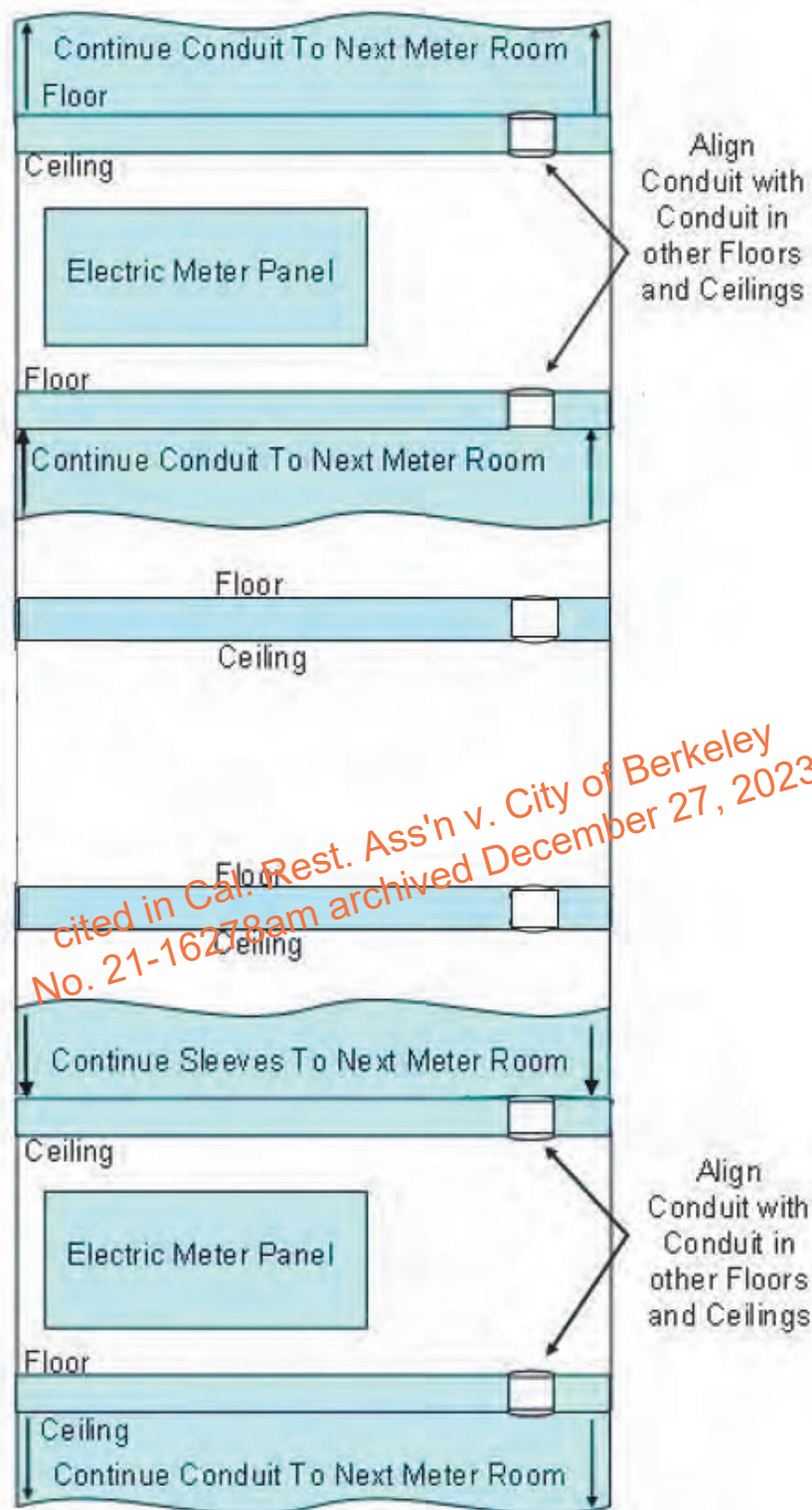


Figure 3  
Vertically Align Meter Rooms

### Smart Meter Electric Network Requirements for Indoor Meter Rooms and High-Rise Buildings

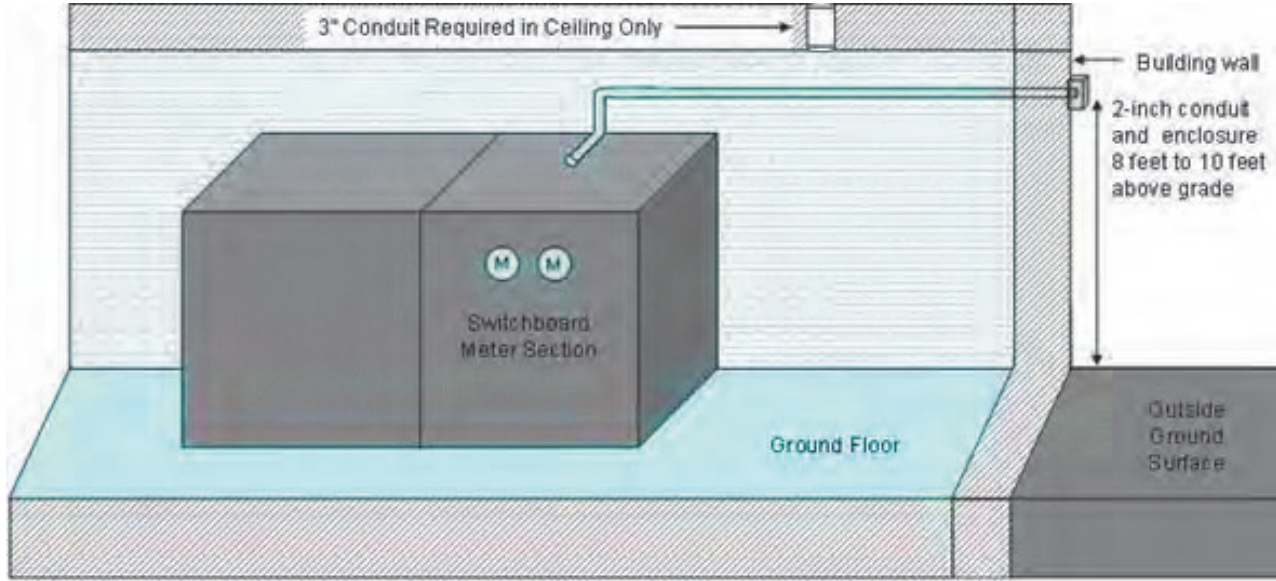


Figure 4  
Detail C – Indoor Electric Meter Room at Ground Floor

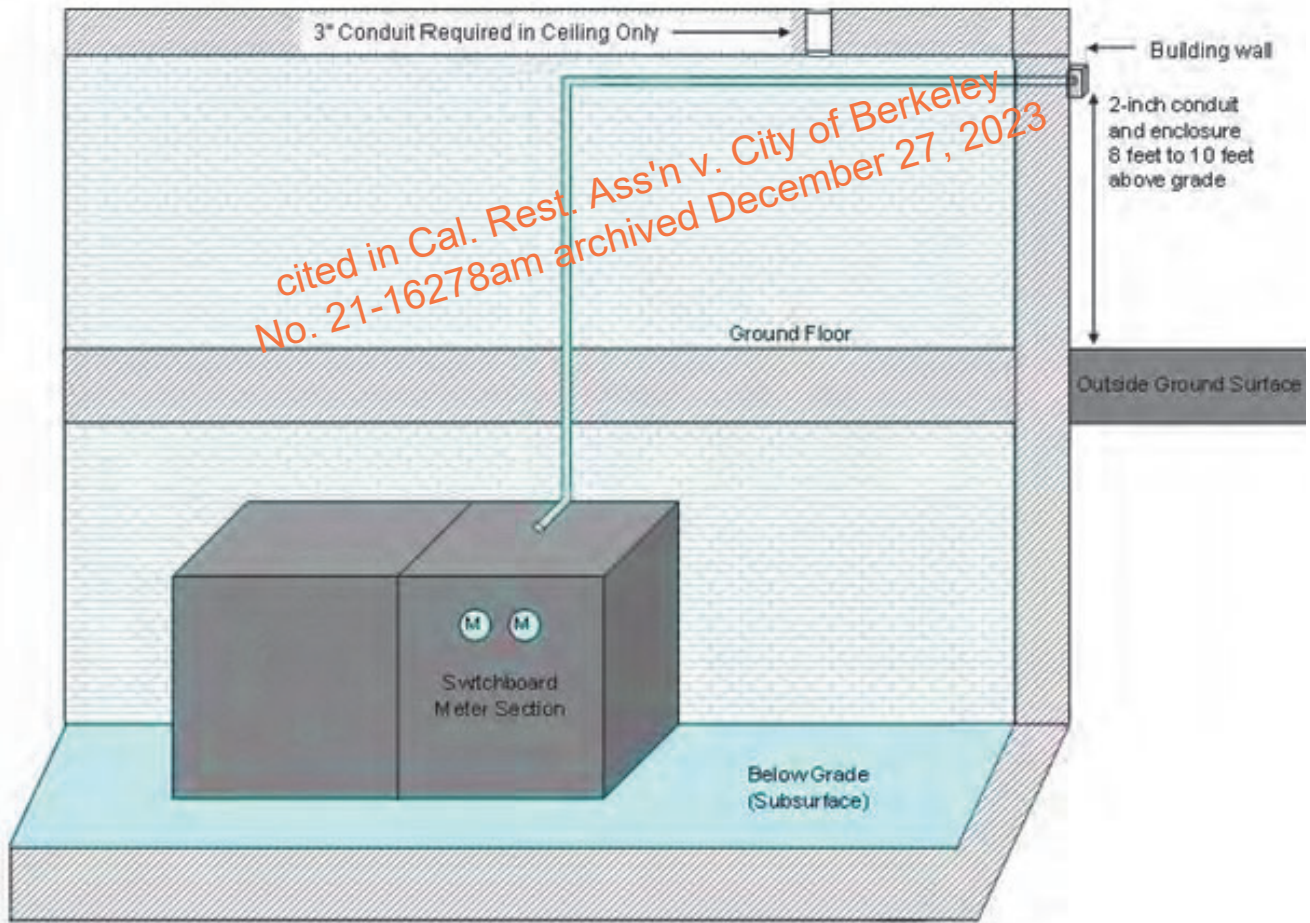
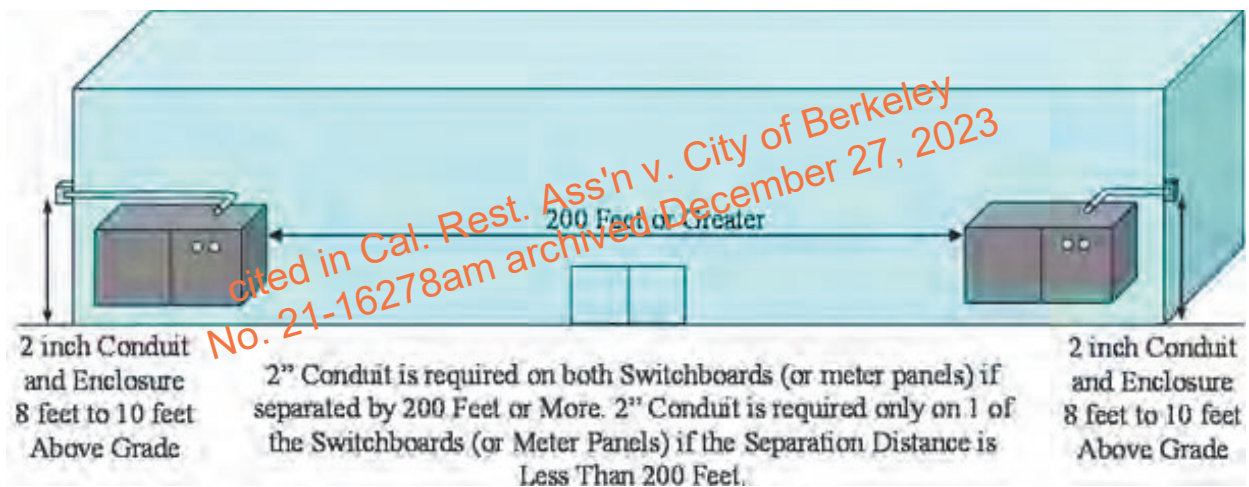


Figure 5  
Indoor Electric Meter Room Below Grade (Subsurface)

*cited in Cal. Rest. Ass'n v. City of Berkeley  
No. 21-16278am archived December 27, 2023*

### Smart Meter Electric Network Requirements for Indoor Meter Rooms and High-Rise Buildings



*cited in Cal. Rest. Ass'n v. City of Berkeley  
No. 21-16278am archived December 27, 2023*

Figure 6  
Multiple Electric Meter Rooms at or Below Ground Floor



## Smart Meter Electric Network Requirements for Indoor Meter Rooms and High-Rise Buildings

---

### Revision Notes

Revision 00 has the following changes:

1. Converted Bulletin TD-7001B-005 to this new numbered engineering document.
2. Updated requirements and Figures throughout.

*cited in Cal. Rest. Ass'n v. City of Berkeley  
No. 21-16278am archived December 27, 2023*

cited in Cal. Rest. Ass'n v. City of Berkeley  
No. 21-16278am archived December 27, 2023



**Know what's below.  
Call before you dig.**

USA Color Coding	
Excavation Site & Underground Facilities	Marking Color
Proposed Excavation	White
Temporary Survey Markings	Pink
Electric	Red
Gas - Oil - Steam Chemical	Yellow
Communication CATV	Orange
Water	Blue
Reclaimed Water Irrigation Slurry	Purple
Sewer	Green
Call 811 Two (2) Working Days Before You Dig!	



*cited in Cal. Rest. Ass'n v. City of Berkeley  
No. 21-16278am archived December 27, 2023*

call 811.com

USA Identificadores del Código de Color	
Sitio de Excavación y de Instalaciones Subterráneas	Colored de Identificación
Excavación Propuesta	Blanco
Marcas Temporarias de Inspección	Rosa
Líneas de Energía Eléctrica, Cables, Conductos y Cables de Iluminación	Rojo
Gas, Aceite, Vapor, Petróleo o Materiales Gaseosos	Amarillo
Líneas, Cables o Conductos de Comunicaciones, Alarma o Señales	Naranja
Agua Potable	Azul
Líneas de Lodos, Irrigación y Agua Recuperada	Purpura
Líneas de Alcantarillado y de Drenaje	Verde
Llame 811 a dos (2) días hábiles antes de excavar!	



**Determina lo que está bajo tierra.  
Llama antes de excavar.**



**Pacific Gas and Electric Company™**

**WE DELIVER ENERGY.™**

# Natural Gas Customers:

Important gas safety information regarding your pipelines



PG&E is responsible for maintaining the system that delivers natural gas, up to and including the gas meter. Customers are responsible for the maintenance of customer-owned piping on their property.

Customer-owned gas lines are all above ground or buried pipelines running from PG&E's gas meter to the customer's house or business, including pipelines leading from a building or home to any additional gas-fired equipment or appliances.

Typically, PG&E does not maintain or inspect customer-owned gas lines, so we've included some safety and maintenance information for you on the reverse side of this flyer. **To speak with one of our gas safety specialists, please call PG&E at 1-888-743-7431 or visit us at [pge.com/safety](https://www.pge.com/safety).**



## Maintain and inspect

We recommend that you periodically have your gas lines inspected for leaks and corrosion. A licensed plumber or contractor can help you locate, inspect and repair pipelines on your property.

Pipelines should be repaired immediately if corrosion or any other unsafe condition is discovered. Ask a PG&E representative or another qualified professional to perform a safety check to restore gas service and relight your appliance pilots.

Para ayuda en español, por favor llame al **1-800-660-6789**

要用粵語/國語請求協助，請致電 **1-800-893-9555**

Để được giúp đỡ bằng tiếng Việt, xin gọi **1-800-298-8438**

"PG&E" refers to Pacific Gas and Electric Company, a subsidiary of PG&E Corporation.  
©2021 Pacific Gas and Electric Company. All rights reserved.  
♻️Printed on recycled paper. ♻️Printed with soy ink. 8.21 CCC-0821-3039

## Prevent damage—dig and plant safely!

Damage from digging is a common cause of pipeline accidents. Whether you are putting up a fence or planting a garden, **call 811 or visit [california811.org](http://california811.org) at least two working days before starting any digging project.** Contractors are required by law to contact 811.



This **FREE** service notifies PG&E and other utilities to locate and mark the approximate location of their underground lines.

Digging still poses a risk to customer-owned gas lines since these lines cannot be located by contacting 811. A licensed contractor or plumber can help you locate these lines. Remember to keep a record for future work.



## Learn about installing an Excess Flow Valve (EFV)

An EFV is a safety device that automatically closes and significantly restricts unplanned or excessive natural gas flows in the event the pipeline is severed by digging. Please visit [pge.com/excessflowvalve](http://pge.com/excessflowvalve) to learn more.

*cited in Cal. Rest. Ass'n v. City of Berkeley  
No. 21-16278am archived December 27, 2023*